

## **PROJECT MANUAL**

---

Project Number **GL-2011-04**

**BP-118 FF&E**

Project Name **GLASTONBURY EAST HARTFORD ELEMENTARY MAGNET SCHOOL**

Project Address **95 Oak Street, Glastonbury, CT**

FT Project Number **H090230**

State Project No. **STATE PROJECT NO. 054-0095 MAG/N/PS  
PHASE 3 OF 4**

Submission Date **September 26, 2011**

Volume **I of I**

Division **MOVEABLE EQUIPMENT**



## PROJECT TEAM INFORMATION

### **ARCHITECT**

Fletcher-Thompson, Inc.  
3 Corporate Drive  
Shelton, Connecticut 06484  
Contact: Kate Ryan  
Tel. 203-225-6500  
Fax. 203-225-6800  
E-Mail. kryan@ftae.com

### **TECHNOLOGY CONSULTANT**

D'Agostino & Associates  
425 Owls Roost  
Shelton, Connecticut 06484  
Contact: Marc J. D'Agostino  
Tel. 203-402-0450

### **CONSTRUCTION MANAGER**

The PIKE Company  
1224 Mill Street Building B  
East Berlin, Connecticut 06023  
Contact: Debra Martynowicz  
Tel. 203-228-6695

### **OWNER**

Town of Glastonbury  
2155 Main Street  
Glastonbury, Connecticut 06033

### **OPERATOR**

Capitol Region Education Council  
111 Charter Oak Avenue  
Hartford, Connecticut 06106  
Tel. 860-247-2732

### **MOVE MANAGEMENT**

ORM  
21 Talcott Notch Road, Suite 4  
Farmington, Connecticut 06032  
Contact: Julia Tibbo  
Tel. 860-676-2200

END OF SECTION

THIS PAGE INTENTIONALLY LEFT BLANK

## TABLE OF CONTENTS

### **INTRODUCTORY INFORMATION**

Section 00001	Project Title Page	2 pages
Section 00002	Project Team Information	2 pages
Section 00003	Table of Contents	2 pages
Section 00004	List of Drawings	2 pages

### **BIDDING REQUIREMENTS**

Section 001116	Invitation to Bid / Legal Notice	2 pages
Section 002113	Instructions to Bidders	16 pages
Section 00210	Supplementary Instructions to Bidders	12 pages
Section 00310	Town of Glastonbury Insurance Requirements	2 pages
Section 00410	Quotation/Bid Proposal Form	19 pages
Section 00420	Addendum Receipt Form	2 page
Section 00430	Substitution Request Form	1 page
Section 00440	Bid Bond – AIA Document A310	4 pages
Section 00450	Contractor’s Qualification Statement – AIA Document A305	6 pages
Section 004513	Bidder Qualifications- Questionnaire	10 pages
Section 004519	Non-Collusion Affidavit	2 pages
Section 004520	Surety Letter of Intent	1 page

### **CONTRACTING REQUIREMENTS**

Section 00610	Performance Bond – AIA Document A312 DRAFT	7 pages
Section 006113	Bonds	2 pages
Section 00700	General Conditions of the Contract for Furniture, Furnishings and Equipment – AIA Document A251 DRAFT	14 pages
Section 007319	The PIKE Company Site Specific Safety Plan	7 pages
Section 007322	Town of Glastonbury Code of Ethics	16 pages
Section 007322	Town of Glastonbury Code of Ethics Acknowledgement Form	1 page
Section 007340	Prevailing Wage Rates	2 pages

### **FURNITURE REQUIREMENTS**

Section 12000	Fixtures, Furnishings & Equipment Specifications	352 pages
Section 18000	Room by Room Matrix	32 pages

END OF SECTION

THIS PAGE INTENTIONALLY LEFT BLANK

## LIST OF DRAWINGS

<u>DRAWING NO.</u>	<u>DRAWING TITLE</u>
	Cover
F-100.1	Lower Level Furniture Plan- Part A
F-100.2	Lower Level Furniture Plan- Part B
F-101.1	First Floor Furniture Plan- Part A
F-101.2	First Floor Furniture Plan- Part B
F-101.3	First Floor Furniture Plan- Part C
F-102.1	Second Floor Furniture Plan- Part A
F-102.2	Second Floor Furniture Plan- Part B

END OF SECTION

THIS PAGE INTENTIONALLY LEFT BLANK



## INVITATION TO BIDDERS / LEGAL NOTICE

Town of Glastonbury  
EAST HARTFORD / GLASTONBURY ELEMENTARY MAGNET SCHOOL  
Glastonbury, Connecticut  
State Project Nos. #054-0095 MAG / N / PHASE 3 OF 4

The Town of Glastonbury will receive sealed Bids (**in triplicate**) for the individual Bid Packages identified below for East Hartford / Glastonbury Elementary Magnet School. Bids will be received only at the Office of the Purchasing Agent, Glastonbury, Connecticut, Town Hall, 2155 Main Street (second level), Glastonbury, CT 06033, Attn: Mary F. Visone, Purchasing Agent, until 11:00 AM (local time) on dates shown below; shortly following receipt of the bid packages they will be publicly opened and read aloud. Late bids will not be accepted.

<u>Bid Package</u>	<u>General Description</u>	<u>Due Date and Time</u>
GL-2011-04 BP - 118	*Movable Equipment	March 27 <sup>th</sup> 2012 @ 11:00 AM
GL-2011-04 BP - 119	*Technology Equipment	March 27 <sup>th</sup> 2012 @ 11:00 AM

Scope of bid includes:

Movable Equipment. The furniture, fixtures & equipment will include general classroom furniture including desks, and chairs, cafeteria tables and chairs, computer stations, science equipment and art tables and equipment, and other related equipment.

Technology & Equipment. The Technology & Equipment will include computers, access controls, video, surveillance, phone systems & network equipment.

Bidders may obtain a complete set of plans and specifications (contract documents) containing a one-volume Project Manual and a set of drawings at the Town of Glastonbury Facilities Office located at 2143 Main Street, Glastonbury, CT 06033.

Times available for pick will be Monday thru Friday between the hours of 8:00AM and 4:00PM. Bidders shall sign for receipt of bid documents.

A pre-bid meeting (not mandatory) will be held at Glastonbury Town Hall, 2155 Main Street, Glastonbury, CT 06033 in the Town Council Chambers at 10:00 A.M. on March 15<sup>th</sup>, 2012.

The Town of Glastonbury reserves the right to accept or reject any or all Bids in whole or in part, or to waive any informalities, irregularities, omissions or technical defects in the bids if it is deemed by the Town to be in its best interest. All Bids shall stand for acceptance for a period of ninety (90) days from the actual time of the bid opening. Should there be any reason why the bid cannot be awarded within the specified period of time, the time may be extended by mutual agreement between the Town and the Bidder.

**All Requests For Information** shall be submitted in writing to ONLY the Architect's representative: Ms. Kate Ryan, Fletcher-Thompson, Inc., Architects/Engineers, Shelton, Connecticut 06484, or at [kryan@ftae.com](mailto:kryan@ftae.com), no later than five (5) business days prior to bid due date.

Sealed proposals must be accompanied with Bid Security and Surety Letter of Intent. **Bid Security** shall be made payable to the "Town of Glastonbury" in the form of a certified check or Bid Bond in the **Amount of 10% of the Bid Amount**. Bid Bonds are required for all bids. The Bid Bond must be issued by a surety company licensed in the State of Connecticut. Construction Performance Bond and Labor and Material Payment Bonds for 100% of the contract price, with a surety company satisfactory to the Owner, shall be furnished by the Bidder awarded the contract. Performance and Labor and Material bonds are required for any bid amount of \$50,000.00 or more. The Town of Glastonbury will not be liable for the accrual of any interest on any certified checks submitted. Cashier's checks will not be accepted.

The successful Bidder is required to comply with all provisions of the Civil Rights Act of 1964, the Equal Opportunity

Act of 1972, Executive Orders #3, No. 17, 11246, 11375 and 11478. The requirements for Bidders under this contract are explained in the Project Manual including the insurance requirements of the Town of Glastonbury. Contractors shall comply with State Statutes concerning Employment, Wage Rates and Labor Practices, where applicable, and Section 31-53 of the Connecticut General Statutes as amended.

Bidders are reminded that Public Schools are exempt from Federal Excise Taxes as well as State of Connecticut Sales, Use and Service Taxes, to the extent provided by law, which should not be included in the Bidder's proposal.

The Town of Glastonbury is an Affirmative Action / Equal Opportunity Employer. Minority / Women Business Enterprises are encouraged to quote.

END OF SECTION

## INSTRUCTIONS TO BIDDERS SECTION 00 21 13

### TO: ALL CONTRACTORS BIDDING

**RE: GLASTONBURY/ EAST HARTFORD ELEMENTARY MAGNET SCHOOL  
95 Oak Street, Glastonbury, Connecticut**

You are invited to submit your Bid proposal for furnishing all field supervision, labor, materials, equipment, hoisting, tools and all other items necessary to furnish and complete a portion of the work for the above Project. The following information is for your use in preparing your bid:

**All proposals to be submitted in triplicate and shall be received by the Office of the Purchasing Agent, Mary Visone, Town of Glastonbury, Town Hall, 2155 Main Street, Glastonbury, Connecticut 06033 ("The Owner")** until the time and the date(s) shown in the Invitation to Bid for each individual Bid Package. Shortly following the receipt of packages they will be opened publicly and read aloud. Late bids will not be accepted.

**All proposals must be accompanied by Bid Security and a Surety's Letter of Intent;** (reference Section 00 45 20). Bid Security shall be in the form of a Certified Check or Bid Bond on AIA Document A310 issued by a Surety Company which meets qualifications as specified. Bid Security shall be addressed to the Town of Glastonbury for the amount not less than ten percent (10%) of the total bid amount.

**Each Bid must be in a Sealed Envelope,** addressed to the Office of the Purchasing Agent, Mary Visone, Town of Glastonbury, Town Hall, 2155 Main Street, Glastonbury, Connecticut 06033. Each sealed envelope containing a Bid must be marked on the outside of the envelope clearly labeled ***Bid for Glastonbury East Hartford Elementary Magnet School Movable Equipment***, GL-2011-04, BP-118.

Each Bid Proposal must contain the following documents and any additional documents as noted in throughout the contract documents and thereof made by Addendum. **Each Bid Proposal shall be submitted in TRIPLICATE (1 original, plus 2 copies).**

### BIDDING REQUIREMENTS

1. Bid Form
  - a. Quotation / Bid Proposal Form
  - b. Substitution Request Form and Alternate Prices (if applicable)
  - c. Addendum Receipt Form- Acknowledgement of Addendums
2. Bid Bond (for 10% of the total Bid Amount)
3. Surety's Letter of Intent (payment & performance bond for any Bid Amount of \$50,000.00 or more) Ref. Section 00 45 20
4. Bidder's Qualifications Questionnaire (Section 00 45 13)
5. Non-Collusion Affidavit (Section 00 45 19)
6. Critical Deadline List
7. The Contract Documents have been organized by unit bid price for quantities indicated. Bidder may submit on any product, but a unit bid price must be included on products in Bid Submission.
8. Each Bidder shall submit with its bid, a project schedule indicating, for each manufacturer,

critical deadlines required for the Bidder to guarantee the installation dates noted in the Contract Documents, including such items as receipt of purchase orders or contract, selection of colors and fabrics, shipping dates, delivery dates, installation durations.

9. Warranty Information.

## **CONSTRUCTION TERMS & DEFINITIONS**

### **2.0 DEFINITIONS**

- A. Bidding Documents include the Invitation to Bid, Instructions to Bidders, the Form of Proposal, other sample Bidding and contract forms and the proposed Contract Documents including any Addenda issued prior to receipt of bids. The Contract Documents proposed for the Work consist of the Drawings, the Specifications and all Addenda issued prior to and all Modifications issued after execution of the Contract.
- B. All definitions set forth in the General Conditions of the Contract for Construction, or in other Contract Documents, are applicable to the Bidding Documents.
- C. Addenda are written or graphic instruments issued by the Architect prior to the execution of the Contract which modify or interpret the Bidding Documents by additions, deletions, clarifications or corrections.
- D. Unit Price is an amount stated in the Bid as a price per unit of measurement for materials or services as described in the Bidding Documents or in the proposed Contract Documents to be added or deducted by change order to the contract price.
- E. Owner is the Town of Glastonbury, Connecticut, 2155 Main Street, Glastonbury, CT 06033.
- F. Architect is variously referred to on plans, specifications and/or contracts as Architect, Architect/Engineer or Engineer. Architect is Fletcher–Thompson, Inc., Suite 500, Three Corporate Drive, Shelton, Connecticut 06484.
- G. All references to "Contractor" means the Contractor performing work under that specific Specification Section or Bid Package.
- H. A Bidder is a person or entity who submits a Bid. All references to "Bidder" means the "Contractor" once the Contract has been awarded.
- I. Specification reference to "Provide" means to furnish and install unless otherwise noted.
- J. Unless otherwise specified, any reference to "Days" throughout the Contract Documents shall refer to calendar days. Duration "Days" in the schedule are normal week days (5 day week).
- K. Regarding to this Definitions Section the final determination as to any conflicts or interpretations shall be made by the Architect, acting in good faith, and in accordance with the Contract Documents.

### **3.0 BIDDER REPRESENTATION**

#### **3.1 BIDDERS by making a Bid represent that:**

- A. Bidder has read and understands the Bidding Documents and his Bid is made in accordance therewith.
- B. Bidder has visited the site, has familiarized himself with the local conditions under which the Work is to be performed and has correlated his observations with the requirements of the proposed Contract Documents.
- C. Bids shall be based upon the materials, systems and equipment required by the Bidding Documents without exception.
- D. If required in the Construction Documents, the Bidder shall comply with all State/Federal Prevailing Wage Laws and any specified Affirmative Action Policies.

#### **3.2 SITE VISITS**

- A. A Non-Mandatory Pre-Bid Conference will be held at the Town Council Chambers, Town Hall 2155 Main Street, Glastonbury, CT, reference Invitation to Bid.
- B. Bidders are expected to personally inspect the project site and make judgments necessary to correlate with the bidding documents all the conditions under which the work is to be performed, actual conditions of the premises, existing construction, and the progress of the work. Neglect of this requirement will not be accepted as reason for delay in the work or adjustment of the contract sum. Arrangements for visiting the site can be made and coordinated with the Move Manager: ORM.

### **4.0 BIDDING DOCUMENTS**

#### **4.1 COPIES**

- A. Bidders may obtain complete sets of the Bidding Documents from the Town of Glastonbury Facilities Office, 2143 Main Street, Glastonbury CT 06033.
- B. Bidders shall use complete sets of Bidding Documents in preparing Bids; neither the Construction Manager, Owner nor the Architect/Engineer assume any responsibility for errors or misinterpretations resulting from the use of incomplete sets of Bidding Documents.
- C. The Owner, Construction Manager or Architect in making copies of the Bidding Documents available on the above terms do so only for the purpose of obtaining Bids on the Work and do not confer a license or grant for any other use.
- D. Failure by this Bidder to view all Drawings, Specifications and Addendums include requirements of its trade shown on ALL drawings and specifications does not relieve the contractor of any responsibilities in providing ALL work of its trade shown on all plans and specifications.

- E. Any bidder which obtains or views plans and specifications from or at any source other than the Town of Glastonbury has the responsibility to keep themselves informed of any addenda or other changes in the Bid Documents or Bid Instructions. The Owner assumes no obligation to keep subcontractors or suppliers advised of such changes. Notice of all Addenda will be publicized on the Owner's Purchasing Department web site. It is the Bidder's responsibility to check the Owner's Purchasing Department's Website for such notices of addenda.

#### **4.2 INTERPRETATION OR CORRECTION OF BIDDING DOCUMENTS**

- A. Bidders shall promptly notify the Architect and the Owner of any ambiguity, inconsistency or error which they may discover upon examination of the Bidding Documents or of the site and local conditions.
- B. Bidders requiring clarification or interpretation of the Bidding Documents must submit the questions in writing no later than five (5) business days prior to the date for receipt of Bids to the Architect ONLY.
- C. Communications regarding any questions shall be directed to ONLY the Architect. NOTE: Any answers received directly from the Owner, Architect or Engineers will not be binding, unless published via an addendum. All oral answers from any source will not be binding.
- D. All questions regarding any information contained in the Bid Documents must be made in writing to the Architect.
- E. Any interpretation, correction or change of the Bidding Documents will be made by Addendum. Interpretations, corrections or changes of the Bidding Documents made in any other manner will not be binding, and Bidders shall not rely upon such interpretations, corrections and changes.
- F. Subject to the provisions below, in case of conflict in or between Contracts, plans, specifications, Special Instructions and Proposal Requirements or this Instruction to Bidders the following shall be the precedence for resolving same:
  - Special Instructions and Proposal Requirements for Bid Packages
  - Bid Package Scope of Work
  - Instructions to Bidders
  - Contract Agreement
  - Supplementary Conditions
  - General Conditions
  - Large Scale Drawings
  - Small Scale Drawings
  - Specifications
  - Addendum
- G. In the absence of an interpretation, should the Drawings disagree in themselves or with the Specifications, the better quality or the greater quantity of work or materials shall be estimated upon, and unless otherwise ordered, shall be furnished.
- H. Communications regarding any questions shall be directed to the Architect.

- I. All Bidders are put on notice that they should carefully examine all Bid Documents to ensure that they include all items intended to be included in their scope of work. The Bidder acknowledges that the proposed Contract Documents are complete, accurate and sufficiently clear in scope and intent to permit the complete and proper construction of the Work, with the exception that any errors, omissions, ambiguities or perceived defects in the proposed Contract Documents known to the Bidder which have not been addressed in Addenda prior to the date of its Bid are to be set forth in an attachment to the Bid. Bidder agrees and acknowledges that, in the absence of such statement; Bidder has not discovered or been made aware of any such errors, omissions, ambiguities or perceived defects.
- J. All Bidders shall make themselves aware of scopes of work identified on all drawings for every bidder for every Bid Package, coordinate their bid and their work with that work and shall include in their bid any of their work as described therein.
- K. Failure by this Bidder to view all Drawings, Specifications and Addendums and include requirements of its trade shown on ALL drawings and specifications does not relieve the contractor of any responsibilities in providing ALL work of its trade shown on all plans and specifications.

#### **4.3 DRAWINGS**

- A. Drawings are listed In the Project Manual and any subsequently issued drawings by Addenda.
- B. All Bidders are responsible to assure that they have all drawings listed in the List of Drawings contained in the Project Manual and any drawings or sketches added, deleted or revised by Addenda.
- C. All Bidders shall make themselves aware of scopes of work identified on all drawings for every bidder for every Bid Package, coordinate their bid and their work with that work and shall include in their bid any of their work as described therein.
- D. Failure by this Bidder to view all Drawings, Specifications and Addendums and include requirements of its trade shown on ALL drawings and specifications does not relieve the contractor of any responsibilities in providing ALL work of its trade shown on all plans and specifications.

#### **4.4 SPECIFICATIONS**

- A. The Specific section(s) of Specifications being bid by Contractor and all other Specifications for the Project contained in "Project Manual, Movable Equipment, Glastonbury East Hartford Elementary Magnet School, Glastonbury, Connecticut" dated September 26, 2011.
- B. Delivery/Installation Schedule under section 00210 Supplementary Instructions to Bidders.

- C. Special Instructions and Proposal Requirements for all other Bid Packages, attached. All bidders are to completely familiarize themselves with all Bid Packages and include in their quotation their work referenced in other Bid Packages even if it is not specifically stated in the Bid Package they are bidding.
- D. This Instruction to Bidders dated September 26, 2011.
- E. Insurance requirements are contained in General Conditions and Supplementary Conditions to General Conditions, attached. Insurance Limits are contained in sample AIA A251 Contract.
- F. Prevailing Rate Determination and other material from State of Connecticut see section 007340
- G. All Bidders are responsible to assure that they have all the specifications described in the Table of Contents in the Project Manual and any specifications added, deleted or revised by Addenda.
- H. All Bidders shall make themselves aware of scopes of work identified in the specifications for every bidder for every Bid Package, coordinate their bid and their work with that work and shall include in their bid any of their work as described therein.
- I. Failure by this Bidder to view all Drawings, Specifications and Addendums include requirements of its trade shown on ALL drawings and specifications does not relieve the contractor of any responsibilities in providing ALL work of its trade shown on all plans and specifications.

#### **4.5 REQUEST FOR CLARIFICATION**

- A. All Requests for clarification shall be sent to the Architect ONLY.
- B. All Request for clarification shall be made as soon as possible, and in no case no later than five (5) business days before bids are due.
- C. All questions regarding any information contained in the Bid Documents must be made in writing to the Architect.
- D. Answers will be given in writing to all Bidders in the form of an Addendum. Oral answers will not be binding.
- E. **All questions regarding information contained in the Bid Documents must be made in writing to the Architect.** To expedite answers to questions, please send your request for clarifications via Email to the Attention: Kate Ryan at Email: Address: [kryan@ftae.com](mailto:kryan@ftae.com). Should Bidder not have the ability to send by email they can Fax their questions: Fax # (203) 225-6800.
- F. Addenda as applicable covering these clarifications and interpretations will be posted to the Owner's website: [www.glastonbury-ct.gov](http://www.glastonbury-ct.gov) . It is the bidder's responsibility to check the owner's website for any addenda. Neither the Construction Manager, Owner, Architect or Engineers will assume any responsibility for any other explanations or interpretations of the bidding documents.



#### **4.6 ADDENDA**

- A. Addenda will be posted to the Owner's website: [www.glastonbury-ct.gov](http://www.glastonbury-ct.gov). It is the bidder's responsibility to check the owner's website for any addenda. Neither the Construction Manager, Owner, Architect or Engineers will assume any responsibility for any other explanations or interpretations of the bidding documents.
- B. Copies of Addenda will be made available for inspection wherever Bidding Documents are on file for that purpose.
- C. Each Bidder shall ascertain prior to submitting his bid that he has received all Addenda issued, and shall acknowledge their receipt on the Bid Form.
- D. Neither the Architect nor Owner assumes any responsibility for any explanations or interpretations of the bidding documents other than the addenda.

#### **5.0 BIDDING PROCEDURE**

##### **5.1 FORM AND STYLE OF BIDS**

- A. Bids shall be submitted on forms identical to the form included with the Bidding Documents, in the quantity required by the Invitation to Bid.
- B. The Bid Form and ALL Attachments, including the Bid Bond and any other items required in the bid package MUST be submitted in TRIPLICATE; (1) original and (2) copies.
- C. Bids are to be Total Bid Proposal with no exceptions or escalation clauses.
- D. Bidders are to include all costs required as a result of annual (July 1) changes to State Prevailing Wage Rate and Fringe Benefit changes (See CGS 31-53, as amended).
- E. All blanks on the bid form shall be filled in by typewriter or manually in ink. The owner's interpretation of any items left blank will represent the contractor as offering no-bid for that item.
- F. Where so indicated by the makeup of the bid form, sums shall be expressed in both words and figures, and in case of discrepancy between them, the amount written in words shall govern.
- G. Any lining out, alteration or erasure must be initialed by the signer of the bid.
- H. Contractors are responsible to bid on all Alternates and Unit Prices, if no change in the Base Bid the Contractor shall enter "No Change."
- I. Combination Bids will NOT be accepted, unless otherwise indicated on the bid form.
- J. Each copy of a Bid shall include the legal name of the Bidder and a statement that the Bidder is a sole proprietor, a partnership, a corporation, or some other legal entity. Each copy shall be

signed by the person or persons legally authorized to bind the Bidder to a contract. A bid by a corporation shall further give the state of incorporation and have the corporate seal affixed. A bid submitted by an agent shall have a current power of attorney attached certifying the agent's authority to bind the Bidder.

## **5.2 BID SECURITY AND LETTER OF SURETY**

- A. All proposals must be accompanied by Bid Security in the form of a Certified Check or Bid Bond on AIA Document A310, February 1970 Edition, issued by a Surety Company which meets qualifications below. Bid Security shall be in amount not less than ten percent (10%) of the total amount of the Bid, and shall be addressed to the Town of Glastonbury; reference (Section 00 45 20).
- B. The Bid Bond and the Letter of Surety must be provided by a Surety Company or Companies that meet the qualifications. Reference (Section 00 45 20).

## **5.3 SUBMISSION OF BIDS**

- A. All Bid proposals shall be submitted to the ("Owner") Town of Glastonbury, to the attention of the Town Purchasing Agent, Mary Visone, located at the Town Hall, 2155 Main Street, Glastonbury, Connecticut 06033.
- B. Bids must be submitted prior to the time and date for receipt of Bids indicated in the Invitation to Bid, or any extension thereof made by Addendum. The Town of Glastonbury Purchasing Office will be the sole entity determining the date and time that a bid is received and whether or not that bid is on time or late. Bids received after the date and time for receipt will NOT be accepted.
- C. The Bidder shall assume full responsibility for timely delivery at the location designated for receipt of Bids.
- D. Oral, telephonic, telegraphic, faxed bids or electronically transmitted bids will NOT be accepted.
- E. Bids will be publicly opened and read aloud at the Town Hall, shortly following the time the bids are due.
- F. **Each Bid MUST BE Submitted in a SEALED ENVELOPE and Addressed to the Office of the Purchasing Agent, Mary Visone, Town of Glastonbury, Town Hall, 2155 Main Street, Glastonbury, Connecticut 06033, and marked on the outside with the following information:**

<b>ATTENTION:</b>	<b>Office of PURCHASING AGENT - Mary Visone</b>
<b>TO:</b>	<b>Town of Glastonbury</b>
	<b>2155 Main Street</b>
	<b>Glastonbury, CT 06033</b>
<b>PROJECT NAME:</b>	<b>Glastonbury- East Hartford Elementary Magnet School</b>
<b>TOWN BID No.</b>	<b>GL-2011-04</b>
	<b>BP -118 FF&amp;E</b>
<b>BID PACKAGE DESCRIPTION</b>	<b>___ Movable Equipment ___</b>
<b>DATE &amp; TIME OF BID DUE:</b>	<b>Date: _____ Time: _____</b>
<b>BIDDER NAME:</b>	_____
<b>ADDRESS:</b>	_____
<b>CITY, STATE, ZIP CODE:</b>	_____

- G. Bid must include Unit Prices, which includes all costs necessary for the complete delivery, installation, trash removal off site, cleaning & final placement of such Unit Work.
- H. Bidder shall complete and properly execute Non Collusion Bidding Affidavit with the Bid Form.
- I. Bidder shall include a completed Contractor Qualification Questionnaire with all bids; reference (Section 00 45 13).
- J. Bids and Contract Awards are subject to all applicable Federal, State and Local codes, laws, ordinances, charters, regulations and rules. By submitting a Bid, Bidder agrees to indemnify and hold harmless the Town of Glastonbury, its Board of Education, CREC, the Construction Manager, the Architect and their consultants for all damages assessed against any of them as a result of the Bidder's failure to comply with said standards and/or regulations.
- K. Submission of a bid by a bidder signifies that if awarded a purchase order for this contract, the contractor will fulfill his/her obligations for the contract. Refusal to accept the purchase order or exceptions taken to the Agreement during or after bidding will give the Owner the right to reject the bid and the Owner reserves all its rights as a result of said rejection including recovery of the Bid Security from Contractor.

#### **5.4 NON-DISCRIMINATION IN EMPLOYMENT AND AFFIRMATIVE ACTION**

- A. All Contractors must certify and comply with all applicable requirements of Federal Executive Order No. 11246 as amended and State of Connecticut Executive Orders Three and Seventeen. By submitting its Bid, Bidder agrees and warrants that they will not discriminate, or permit discrimination, against any person or group of persons on the basis of race, color of skin, religion, national origin, sex, sexual orientation or physical disability including, but not limited to, blindness, unless it is shown by said Bidder that such disability prevents performance of that which must be done to successfully fulfill the terms of this sealed bid or in any manner is prohibited by the laws of the United States or the State of Connecticut; and further agrees to provide, if requested, such information as the Human Rights Commission requires concerning employment practices and procedures of the Bidder. The Town requires that, prior to Contract award, the Bidder must provide the Town with a properly executed Affirmative Action Statement (to be provided by the Town.)

#### **5.5 MODIFICATION OR WITHDRAWAL OF BID**

- A. A bid may NOT be modified, withdrawn or canceled by the Bidder for a period of Ninety (90) days following the time and date designated for the receipt of bids, and each Bidder so agrees in submitting his bid.
- B. Prior to the time and date designated for receipt of Bids, any Bid submitted may be modified or withdrawn by notice to the party receiving Bids at the place designated for receipt of Bids. Such notice shall be in writing over the signature of the Bidder or by telegram or facsimile; if by telegram or facsimile, written confirmation over the signature of the Bidder shall be mailed and postmarked on or before the date and time set for receipt of Bids, and it shall be so worded as not to reveal the amount of the original Bid.
- C. Withdrawn Bids may be resubmitted up to the time designated for the receipt of Bids provided that they are then fully in conformance with these Instructions to Bidders.

#### **6.0 CONSIDERATION OF BIDS**

##### **6.1 OPENING OF BIDS**

- A. Properly identified Bids received on time will be opened publicly.

##### **6.2 REJECTION OF BIDS**

- A. The Owner shall have the right to reject any or all Bids and to reject a Bid not accompanied by any required bid security or by other data required by the Bidding Documents, or to reject a Bid which is in any way incomplete or irregular.

### **6.3 ACCEPTANCE OF BID (AWARD)**

- A. It is the intent of the Owner, to award a Contract to the lowest responsive and responsible Bidder provided the Bid has been submitted in accordance with the requirements of the Bidding Documents and does not exceed the budget. The Owner shall reserve the unrestricted right to waive any technical defect, irregularity, formalities or informality in any Bid or Bids received; to reject any or all bids; and to accept the Bid that in its judgment will be in the best interest of the Town of Glastonbury.
- B. In the event that only one bid for a line item unit is received a cost analysis may be made before the award of the Contract. The single bidder may be required to provide additional information and data sufficient to allow the owner to be able to perform a proper analysis.
- C. As a part of the Award process, the Owner may interview more than the Apparent Low Bidder to determine the ability of the Bidders to meet the Project's Schedule and Quality Requirements.
- D. Moveable Equipment shall be awarded on multiple award basis to qualified bidders providing that the bid(s) has been submitted in accordance with the requirements of the bidding documents and does not exceed the funds available, subject to the following conditions:
  - a. The award will be made with the intent to optimize cost and other management factors. The town may evaluate and group line items of similar manufacturers and/ or suppliers to determine the lowest collective price for that grouping of line items in order to minimize the delivery coordination and other management requirements. Additionally, the Town reserves the right to determine the most economical purchase that it determines meets its requirements based on price, compatibility, warranty, service, delivery, freight charges and other factors that it considers relevant.
  - b. The Town shall have the right to accept substitutions as deemed in the best interest of the Town. The Town reserves the right to make a partial award. Should the need arise to make a partial award; the quoted unit item price will be used to calculate the total cost for the quantity of items selected.
- E. Should the bid amounts exceed the budget, the Owner shall reserve the unrestricted right to rebid the project in part or in whole.
- F. All unit prices are to be held by vendor for a minimum of one year from date of purchase order.

### **6.4 TOWN ETHICS CODE/ NON-COLLUSION AFFIDAVIT**

- A. Bidder MUST review the Town of Glastonbury Code of Ethics adopted July 8, 2003 and effective August 1, 2003. It is understood that a bidder submitting a proposal is acknowledgement that they have read and agrees to complete and sign an Acknowledgement Form prior to Contract Award. The Code of Ethics and the Consultant Acknowledgement Form can be accessed at the Town of Glastonbury web site at [www.glastonbury-ct.gov](http://www.glastonbury-ct.gov). Upon entering the web site click on Bids & RFPs, which will bring you to the links for the Code of Ethics and the Consultant Acknowledgement Form. If the Bidder does not have access to the internet a copy of these

documents can be obtained through the Town Purchasing Department at the address listed in these Bid Documents.

- B. Each bidder submitting a bid for any portion of the work contemplated by the documents on which bidding is based shall execute, and attach to their Bid, the Non-Collusion Bidding Affidavit provided under (Section 00 45 19) stating, if true, that they have not colluded with any other person, firm, or corporation in regard to any bid submitted.

## **6.5 REFERENCE CHECKS**

- A. By bidding on this Contract the Contractor agrees that any or all of its past clients may be contacted by the Town of Glastonbury or the Architect. The Contractor bidding on this Contract also agrees to release and discharge, by bidding on this Contract, for the Contractor itself, its heirs, executors, administrators and assigns, release acquit and forever discharge the Town of Glastonbury, its Board of Education, CREC, the Architect and all employees and any or all other persons, firms and corporations of and from any and all actions, causes of actions, claims or demands for damages, costs, loss of services, expenses, compensation, consequential damage or any other thing whatsoever, on account of, or in any way growing out of any former client contacted by the Town of Glastonbury or Architect to obtain an opinion regarding any work performed by the Contractor. The above release shall also include and apply to any former client contacted.

## **7.0 BIDDER QUALIFICATIONS**

- A. BIDDERS MUST submit with their bid, the Contractor's Qualification Questionnaire demonstrating to the Owner's satisfaction that they are qualified; reference (Section 00 45 13).
- B. By submission of a bid proposal the Bidder acknowledges that:
  - 1. Bidder is in receipt of all Bid Documents, including subsequently issued addenda, for the Project at or before the time the Bids are Due.
  - 2. Bidder has not been debarred, or otherwise denied permission, within the past 3 years, to quote or perform State of Connecticut funded projects due to failure to comply with State Regulations or Statutes.
  - 3. Bidder is a licensed Contractor authorized to do business in Connecticut and holds a current Connecticut Tax Number and be current in its State taxes and local taxes, if any apply, in the Town of Glastonbury at the time of bid.
  - 4. All Prime Contractors and Subcontractors are currently Pre-qualified by the State of Connecticut (DAS) Department of Administrative Services for work contained in any Bid Package in which the value of work to be contracted is over the threshold of \$500,000.
  - 5. Bidder agrees to properly execute Acknowledgement Form for the Town of Glastonbury Code of Ethics, acknowledging that the Bidder has reviewed the Code of Ethics and that it understands that the Town will not consider or award any Contract to a Bidder that does not sign the Code of Ethics (as described in the Code); (see attached copy of the Town of Glastonbury Code of Ethics and the Acknowledgement Form, reference the Town of Glastonbury web site.

- C. Bidders MUST include on the Bid Form, a List of their proposed Major Suppliers / (Manufacturers) of Equipment and Materials.
1. All Supplier/Manufacturers are subject to approval by the Owner, Architect and Construction Manager. This approval is also part of the initial determination of the suitability and qualifications of the Bidder as a condition of Contract Award; reference Bid Form.
  2. It is the intent throughout the Specifications that whenever a material or method of some particular manufacturer or process is specified, that that Specification be considered as the standard of quality. The Bid Proposal shall be made in accordance with these Specifications. Approved Equivalent substitutions may be proposed on the basis set forth within the Instruction to Bidders and Contract Documents.
- D. Bidders will be required to establish to the satisfaction of the Architect and the Owner the reliability and responsibility of the persons or (subcontractors) entities proposed to furnish and perform the Work described in the Bidding Documents.
- a. Prior to the award of the Contract, the Architect will notify the Bidder in writing if the Owner, after due investigation, has reasonable objection to any such proposed person or entity. If the Owner or Architect has reasonable objection to any such proposed person or entity, the Bidder may submit an acceptable substitute person or entity with no adjustment in his bid price. The Owner may, at his discretion, review the proposed substituted person or entity or may disqualify the Bidder.
  - b. Persons and entities proposed by the Bidder and to whom the Owner and the Architect have made no reasonable objection the contractor must use them on the Work for which they were proposed and shall not be changed except with the written consent of the Owner and the Architect.
- E. Performance and Payment Bond Requirements.
- a. Any successful Bidder whose bid is \$50,000.00 or more shall furnish a Performance Bond and a Labor and Material Payment Bond each in the amount of 100% of the Contract price payable to the Owner for the full performance of the Contract and for the payment of all obligations arising there under AIA Document 312, 1984 Edition, in a form satisfactory to the Owner; reference (Section 00 61 13).
  - b. The cost of these Performance Bond and Payment Bonds is to be paid by the Contractor and the cost of shall be included in the Bid Proposal.
  - c. Bidder shall deliver the required bonds to the Owner within seven (7) days after the notice of award of Contract.

## **8.0 AGREEMENT BETWEEN OWNER AND CONTRACTOR**

- A. Form of Agreement for the Work between Owner and Contractor will be awarded in the form of a purchase order issued by owner, as referenced in the Contract Documents.
- B. Prior to the delivery of a purchase order, a successful Bidder shall deliver copies of Certificates of Insurance for insurance in the amounts specified in the General Conditions.
- C. The Contract is partially funded by State of Connecticut grant programs. The bidder is advised that such funding programs may include contractual provisions binding on Contractors and which may, for example, require signatures, audits or certifications concerning work performed or payments made.
- D. Financial approval and Owner's Notice to Proceed. If for any reason, the Owner does not obtain proper financing or approval from any governing body or agency to proceed with this Project and, as a result, does not issue to the Contractor a Notice to Proceed within the time limit defined on the Bid Form, the Owner shall not be under any obligation to award Contracts for the Work and all parties, including Bidders, shall have no liabilities or obligations with respect to the other.
- E. Wage Rate Determination for this Project from the State of Connecticut; this is a Prevailing Wage Rate project; reference (Section 00 73 43). Bidder is to anticipate any future increases and include these costs in its quotation.
  - 1. All provisions of all applicable State Labor Standards must be complied with under this Contract. The execution of the Contract by the Bidder binds the Contractor to all applicable State Labor Laws and Regulations.
  - 2. Prevailing Wage Rates change annually on July 1st and all provisions for such changes are to be included in the Bidder's Proposal. No Escalation Clauses will be in the Contract Agreement.
  - 3. Certified payrolls for site labor are required to be submitted weekly to Move Manager
  - 4. All other statutory laws, to the extent they are required to be incorporated into a contract by statute, are hereby deemed fully incorporated herein and in the Contract.
  - 5. Violation of Prevailing Wage Law requirements may cause Contract to be terminated and Architect and Owner reserves all rights if such termination is required.
- F. Contractor is to provide Insurance as noted in AIA General Conditions A201 CMA and AIA Contract Form A101CMA, both as revised in the Bid Documents. Limits and other requirements are listed in Section 00210.
- G. The Town of Glastonbury has obtained an "All Risk"- Builder's Risk Policy on this Project. This insurance shall insure against all named perils such as fire, extended coverage, vandalism and malicious mischief. The policy has a \$5,000 deductible. In the event of a loss, the first \$5,000 is the responsibility of the Contractor. Equipment and Tools of the Trade are at the entire risk of the Contractor.



- H. The Contractor shall protect and secure its materials and equipment against loss, including theft. The Architect will not accept any claim for alleged theft. Contractor will protect its work from damage until its work is complete and accepted for the entire Project.
- I. The Work shall be started on the date set forth in the Notice to Proceed or executed Contract Agreement and shall be completed in the time stated, if any, or as in the bid documents.
- J. In accepting the Proposal, the Owner may reject any, some or all UNIT PRICES quoted by the successful Bidder. All Unit Prices accepted by Owner shall remain binding and irrevocable for entire period of Contract, irrespective of actual amounts of work ordered under such Unit Prices. Rejected unit prices will be negotiated between the Owner and the successful Contractor. The Schedule of UNIT PRICES submitted in the Bidder's Proposal as adjusted and accepted by the Owner will be used as the basis for computing "additions to" or "deductions from" the Contract Price for "Extra Work" and for Work countermanded, reduced or omitted, or awarded as separate Contracts, as may subsequently be provided for in the Contract Agreement.
- K. The Project is Exempt from Connecticut Sales, Service and Use Taxes to the extent provided by Connecticut law. The Contractor will be responsible for taxes on items not incorporated into the project, such as small tools and rental equipment.
- L. Five percent (5%) retainage will be withheld by Owner. Retainage will be withheld until occupancy and acceptance of project and satisfactory completion of Contractor's work including all punch list items and submission of all required closeout, record documents, warranties and guarantees. On a selected basis the Move Manager can recommend to the Owner and Architect a partial reduction in retainage prior to Substantial Completion of the entire project. This reduction is neither obligatory nor automatic and will only be considered on an individual contract basis, subject to various requirements including, but not limited to, completion of all Contractor's work and also Consent of Surety, and is within the Owner's sole discretion, based on the Architect's and Move Manager's recommendations.
- M. The project is owned by the Town and is being constructed on Municipal Property, owned by the Town of Glastonbury, and is thus exempt from Liens. A properly executed Partial Waiver of Claims will be required to be submitted with each Application for Payment.
- N. All Contractors are responsible for the safety of their own employees and they must not allow unsafe work areas whether caused by their own operations or the operations of others. Contractors are required to have their own safety program in effect that promotes safety awareness among its employees.
- O. All Contractors are to comply with State of Connecticut General Statutes concerning OSHA 10 Safety Training for all their employees who perform manual labor on the job site. This does not apply to delivery truck drivers who stay in the cab of their truck and do not perform manual labor on the jobsite. Certifications of OSHA 10 Training are to be provided to the Architect as required by Statute.

- P. Contractor's Superintendents and Foreman must have complete knowledge of the scope of the work, be able to read blueprints, be able to coordinate and communicate effectively with other trades, be able to plan Contractor's work schedule and have thorough knowledge of the latest applicable OSHA standards. No illegal drugs are allowed on the Site nor are spirits or intoxicating materials. Possession shall be the basis for immediate termination of the person in possession of same.
- Q. Other permits, licenses and inspections required by the State of Connecticut or other utilities or regulatory agencies will be obtained and paid for by the Contractor and the cost of same is to be included in its bid. Applications for permits must be reviewed by Architect prior to submission to governing authority. A copy of Contractor's permit applications shall be furnished promptly to Architect prior to start of work. Contractor shall then promptly furnish copies of actual permits to Architect.

END OF SECTION

## **SUPPLEMENTARY INSTRUCTIONS TO BIDDERS**

### **ARTICLE 1: SUCCESSFUL BIDDER'S SCOPE OF SUPPLY**

- 1.1 The successful bidder, also referred to as vendor/contractor, shall, if provided an Owner written notice of lowest responsible bidder status and upon receipt of a purchase order:
- (a) Deliver to a specified indoor location at Glastonbury East Hartford Elementary Magnet School acceptable to the Owner. Tailgate delivery shall not be permitted.
  - (b) Uncrate, unpack or otherwise remove from all shipping containers, pallets, etc. outside of the facility.
  - (c) Provide all required handyman/laborer and tools for, and fully assemble all furniture and equipment per manufacturer recommendations and instructions.
  - (d) Move and position all furniture and equipment to locations set forth in the "Furniture Plan" drawings.
  - (e) Perform utility connections and hookups where required. This includes all items that require hook-ups such as dishwashers, stoves, flags, maps, terrariums, power climbers.
  - (f) Remove & dispose, off-site all crates, packing materials, shipping containers, pallets, etc. from Glastonbury East Hartford Elementary Magnet School property and dispose of said items in a proper and acceptable manner. On-site disposal of refuse is not permitted.
  - (g) Confirm delivery schedule with Move Manager; ORM, Attn: Julia Tibbo, 21 Talcott Notch Road, Suite 4, Farmington, CT 06032-01811, 860-676-2200.
- 1.2 The above tasks are collectively referred to in the Contract Documents and herein as the "delivery".
- 1.3 The Bidder must hold insurance for all awarded items until product approval sign off.

### **ARTICLE 2: CONTRACT DOCUMENTS**

- 2.1 A Contract, if awarded, shall include without limitation the Invitation to Bid, Quotation / Bid Proposal Form, any addenda, the Contractor's Qualification Statement, Bid Specifications, Drawings, Quantity/Specification Matrix and Location Requirements (collectively the "Contract Documents").
- 2.2 The Contract Documents are to be considered as one, and whatever is called for by one shall be as binding as if called for by all. Any discrepancies or questions as to quantities of any items listed in the Specifications and/or shown on the Drawings shall be immediately brought to the attention of the Architect for correction. Any such discrepancies, not

corrected by Addenda, shall be resolved on the basis of furnishing the greater quantity and/or quality without change in contract price.

- 2.3 Successful bidders must adhere to the Site Specific Safety Plan included in the Contract Documents.
- 2.4 Award shall be in the form of a purchase order.

**ARTICLE 3: PREORDERING MEETING, INSPECTION AND EXAMINATION OF THE SITE**

- 3.1 Before ordering any furniture and/or equipment, the successful bidder shall meet with the Owner's Representative to review bid submittal and to verify all dimensions of any and all existing conditions. Coordination of a site visit is to be with the Owner's Move Manager, ORM, Attn: Julia Tibbo; 860-676-2200. The bidder shall be solely responsible for the accuracy of field dimensions. Any differences found shall be submitted to Owner for review and approval before proceeding. No extra compensation will be permitted because of differences between actual dimensions and measurements indicated on the Contract Documents. Successful bidder is to also coordinate deliveries and installation with owner's on-site representative.

**ARTICLE 4: FIELD DIMENSIONS AND PRODUCT HANDLING**

- 4.1 The successful bidder is required to uncrate furniture and equipment outside the school building. Removal of packaging and packing materials will be permitted to the extent necessary to protect the furniture and equipment. It will be the successful bidder's responsibility to provide temporary protection facilities in case of inclement weather during furniture or equipment packing material removal.
- 4.2 The successful bidder is responsible for details and dimensions not controlled by job conditions. All required field dimensions beyond his control should be communicated to the Architect in writing through either Shop Drawings or other method. The successful bidder shall cooperate to establish and maintain these field dimensions.
- 4.3 Each sheet of Shop Drawings or Product Data shall identify the Project, Supplier and Fabricator or Manufacturer and the date of the Drawing. All Shop Drawings shall be numbered in consecutive sequence and each sheet shall indicate the total number of sheets in a set. Shop Drawings are to be sent to Kate Ryan via email at [kryan@ftae.com](mailto:kryan@ftae.com).
- 4.4 The Product Data which consists of manufacturer's or fabricator's pre-printed product literature and data sheets and which are usually transmitted in booklet or brochure form, shall be submitted in unbound indexed brochures, grouped together only by spring clips. No product data may be submitted in a format larger than 11" x 17". Two sets of the product data shall be submitted to the Architect to allow for distribution by the Architect. Send Product Data to Kate Ryan via email at [kryan@ftae.com](mailto:kryan@ftae.com).

- 4.5 Any furniture and/or equipment not scheduled or approved by the Architect, and any tailgate deliveries to the site shall be rejected and the cost of all expenses connected with such rejections shall be the sole responsibility of the successful bidder.
- 4.6 The successful bidder shall take all required precautions to protect furniture and equipment against damage, theft and deterioration on the site and shall respect the work of others. Any damage incurred to the work of others shall be promptly repaired or replaced at the expense of the successful bidder. All items shall be left in the proper location within the building and completely assembled, polished, cleaned, and in proper operating condition, inclusive of all required utility connections and hookups.
- 4.7 Storage of Furniture, and/or Equipment prior to installation is the sole responsibility of the vendor. On-site storage is not permitted.
- 4.8 All items specified herein shall be delivered in an undamaged condition as packaged by the manufacturer, with the manufacturer's seal and label intact.
- 4.9 Assembly of Furniture, and/or Equipment shall take place in a designated staging area. The successful bidders are responsible to properly protect all finished construction including, but not limited to floors, walls, ceilings and devices from damage. Coordination of these spaces is to be through the Move Manager and Owner's Representative.

#### **ARTICLE 5: PRODUCTS, MATERIALS AND SUBSTITUTIONS**

- 5.1 All materials furnished shall be provided by a manufacturer regularly engaged in the manufacture or production of these products.
- 5.2 Materials shall conform to all applicable and current specific local, state and federal regulatory safety codes and Specifications.
- 5.3 The words "or equal" are understood to mean the following:
  - a. The specified materials, products, and equipment described in the bidding documents establish a standard of required function, dimension appearance and quality required, whether or not the words "or approved equal" are used in order to be met by substitution. These materials shall serve as standards and all bids shall be based upon the same.
  - b. Where the phrase " or equal as approved by owner, " occurs in the Contract Documents, the material or method must be so approved for this Work by the Owner.
  - c. The decisions of the Owner shall be final.
- 5.4 Substitutions to the noted manufacturers shall be considered prior to the receipt of bids provided adequate information on the proposed substitution, such as pictures,

specifications performance test data, a sample of the product delivered to the owner for visual inspection, and any other information necessary for evaluation. Each product is to be labeled with a tag indicating 'Item Number' proposing to be substituted and vendor / bidder contact information. Substitution samples shall be delivered to Glastonbury Facilities Director's Office, 2155 Main Street, Glastonbury, CT, ten (10) business days prior to Bid Due Date for Owner and Architect's review.

- 5.5 Provide adequate information on the proposed substitution, such as pictures, specifications and any other information on the proposed product to the architect with the enclosed "Substitution Request Form" via a neatly compiled PDF. Send information to Kate Ryan, Fletcher-Thompson, Inc., Architects/Engineers, [kryan@ftae.com](mailto:kryan@ftae.com) ten (10) business days prior to Bid Due Date.
- 5.6 Substitutions shall be clearly noted on the bid form summary of unit prices by the specified name struck out and the name of the substitute manufacturer written in and check box clearly noted.
- 5.7 The opportunity to propose substituted products shall not be construed as the Owner's acceptance of such products. Acceptance/rejection will be based on comparison of the proposed product with the named manufacturer in terms of design intent, materials, quality of construction, colors/materials, dimensions, availability, etc. Acceptance will require equality with the named manufacturer; similarity will not be sufficient.
- 5.8 This successful bidder shall furnish for approval, as required by the Architect, all samples of construction, finish and colors. Items shall be offered in colors or combinations of colors. All items shall be furnished in accordance with such approved samples. Written approval of finishes must be obtained from the Owner.
- 5.9 The intent of the Contract Documents is to insure the installation of a quality of furniture and/or equipment as listed. The Owner and Architect will be the judge as to the acceptability of any other than that specified.
- 5.10 The burden of proof of the merit of the proposed substitute is upon the contractor who proposed the change. The Architect will have five (5) days prior to the Bid Due Date to respond to the Contractor of the Owner's decision, in consultation with the Architect, of approval or disapproval of the proposed substitution. If Approved the approval will be set forth in an Addendum. Bidders shall not rely upon approvals made in any other manner.
- 5.11 No substitutions will be considered after the Contract award, unless specifically provided in the Contract Documents.

## **ARTICLE 6: INSTALLATION AND ASSEMBLY**

- 6.1 The successful bidder(s) shall coordinate delivery with the Owner's Move Manager, ORM, Attn: Julia Tibbo; 860-676-2200 The successful bidder(s) shall notify the Owner and Architect in writing of the items ready and scheduled for shipment minimum 48 hours prior to delivery.
- 6.2 The Architect may, at his discretion, elect to inspect the completed items at a mutually agreed location and approve or disapprove them for shipment at site.
- 6.3 Approval for shipment by the Architect shall in no way relieve the Supplier of any responsibility outlined in the Contract Documents.
- 6.4 Areas to receive furniture and/or equipment shall be examined and the delivery shall not occur until any defects affecting its installation have been corrected.
- 6.5 Delivery shall not occur until Work of other trades, affecting furniture and/or equipment installation, has been completed.
- 6.6 Furniture and/or Equipment shall be provided where indicated on the drawings, complete in accordance with the specifications and details.
- 6.7 All furniture and/or equipment shall be installed as indicated on the Drawings, including specified heights for adjustable table and chair legs.
- 6.8 All delivery shall be performed in a workman like manner with skilled labor in accordance with manufacturer's instructions.
- 6.9 The successful bidder shall be required to demonstrate that the installed equipment is fully functional in all respects at a time and a place scheduled through the Owner.
- 6.10 It shall be the responsibility of the successful bidder to properly level all furniture equipped with leveling devices for the location designated by the floor plan and location requirements.
- 6.11 Successful bidder must conform to the PIKE Company site specific safety plan section 007319, herein attached.

## **ARTICLE 7: CLEANING, MAINTENANCE AND ACCEPTANCE**

- 7.1 All wrapping, scrap and debris resulting from this work shall be removed from the premises by the vendor. The successful vendor shall then carefully and thoroughly clean to Owner's approval.

- 7.2 The successful vendor shall be responsible for furnishing the services of a competent representative to demonstrate and instruct the Owner's representative of the proper operating and maintenance procedures.
- 7.3 Provide, three bound copies of an operation handbook or brochure that includes replacement parts list, operational instructions, and maintenance or service data on each item.
- 7.4 Final review for written acceptance of the delivery will commence subsequent to written request by the successful bidder to the Architect stating bidder's completion of its work in compliance with the Contract Documents.
- 7.5 All spare parts and components shall be carefully packaged, marked and delivered to the Owner's on-site representative.

#### **ARTICLE 8: CORRECTIONS AND GUARANTEES**

- 8.1 All work and equipment and any items found not in conformance with the Contract Documents shall be repaired or replaced promptly without additional charge.
- 8.2 Defective or rejected equipment shall be temporarily repaired by the successful bidder to permit use until suitable replacement is replaced.
- 8.3 All products shall be guaranteed, for a period of one (1) year from date of written acceptance by the Town of Glastonbury unless otherwise stated. In the case that the manufacturer's standard warranty is different from that of the bidder, the greater shall apply.
- 8.4 Warranty(s) shall be submitted in writing with the Bid response and shall cover both material and installation.

#### **ARTICLE 9: CODE REQUIREMENTS**

- 9.1 In order to meet the needs of persons with disabilities, when applicable all items shall comply with the current Connecticut Basic Building Code including ICC/ANSI A117.1-1998, Section 504 Rehabilitation Act 1973 including the Uniform Federal Accessibility Standards (UFAS) and 504 Regulations, and the Americans with Disabilities Act Title II including the Americans with Disabilities Act Accessibility Guidelines (ADAAG) and ADA Regulations.
- 9.2 All work shall be in conformance with the OSHA Regulations and Life Safety Code.



**ARTICLE 10: SCHEDULE**

10.1 The Schedule is critical to the project. The work must be complete, installed, and functioning per the following schedule. Please note that dates are subject to change. Successful bidder must comply with adjusted dates.

<b>Deployment</b>	<b>Part</b>	<b>Start</b>	<b>End</b>
Deployment I	Lower Level- Parts A & B	July 11, 2012	August 9, 2012
Deployment II	Second Floor – Parts A& B	July 18, 2012	August 16, 2012
Deployment III	Lower Level – Part C	August 6, 2012	August 23, 2012
Deployment IV	Planetarium	September 24, 2012	October 5, 2012

10.2 The dates indicated are the earliest dates that the respective building areas will be available for delivery of equipment. Upon Notification of Award, successful bidders will be contacted by the move manager, Office Relocation Management [ORM], to schedule a review of all awarded FF&E prior to the successful bidder placing any orders. This requirement is expected to be completed within the first two weeks following Notification of Award and should in no way adversely affect the ability to place timely orders for all FF&E. ORM, in conjunction with the successful bidder, shall establish the best delivery and installation timeframe for all of the FF&E within the available construction completion and building access timelines provided by the Construction Manager. Information relating to manufacturers’ lead and delivery times and methods of shipment shall be provided by the successful bidder at that meeting.

10.3 All work must be conducted during normal business hours – 7:00 am – 3:30 pm Monday-Friday except Connecticut Holidays. If work is to be performed outside normal business hours, vendor/contractor is to coordinate with Move Manager. Costs of all expenses connected with failure to coordinate deliveries and work hours shall be the sole responsibility of the successful bidder.

10.4 All premium costs required by the bidder to perform the work that is required during the non-school hours and/or to comply with the completion dates on the construction schedule are to be included in the bidder’s base bid. Additional bidders’ costs related to the use of overtime or additional personnel necessary to complete the work within the stated time completion will not be considered after the award of Contract.

10.5 The elevator will be available for use. Elevator cab walls, frame, flooring, and controls shall be protected from damage and abuse. Coordinate with Move Manager.

**ARTICLE 11: LIQUIDATED DAMAGES FOR FAILURE TO COMPLETE ON SCHEDULE**

11.1 The Owner and the Vendor/Contractor agree that time is of the essence to the Contract

Documents and all obligations there under. The Vendor/Contractor acknowledges and agrees that the Owner will sustain extensive damage and serious loss as a result of the Vendor/Contractor's failure to meet the time schedule established herein. The exact amount of such damages and loss will be extremely difficult to ascertain. Therefore, the Owner and the Vendor/Contractor agree that in the event the Vendor/Contractor fails to meet the time schedule set forth in the Contract Documents, the Owner shall be entitled to retain or recover from the Vendor/Contractor, as liquidated damages and not as a penalty the per diem amounts set forth in this document. It is expressly agreed such liquidated damages are a reasonable pre-estimate of damages the Owner will incur as a result of the Vendor/Contractor failing to meet the schedule.

- 11.2 The Vendor/Contractor is responsible for scheduling its labor and material procurement so as to complete its work within the time periods set forth in the Contract Documents. The Vendor/Contractor is also required to perform its work in such a manner so as not to interfere with or prohibit other Vendor/Contractor from completing their work within the time periods set forth in the Contract Documents. In the event the Vendor/Contractor does not complete its work within the time periods specified and/or if in the opinion of the Owner, interferes with other Vendor/Contractors completing their work within the time specified and the completion of the project is thus delayed, the Vendor/Contractor will be assessed Liquidated Damages at the rate of \$100.00 a day for each day completion is delayed. Notwithstanding the foregoing and as consequence of special circumstances reference is made to the Special Instructions for per diem liquidated damage amounts that shall be applicable to specific work tasks. The Owner may deduct liquidated damages not so deducted from any unpaid amounts due the Vendor/Contractor shall be payable to the Owner and the demand of the Owner, together with interest from the date of the demand plus costs including Attorney's Fees if enforcement proceedings are necessary to collect such amounts.

END OF SECTION

THIS PAGE INTENTIONALLY LEFT BLANK

**Town of Glastonbury Insurance Requirements**

Contractor shall agree to maintain in force at all times during which services are to be performed the following coverages placed with company(ies) licensed by the State of Connecticut which have at least an "A-" VIII policyholders rating according to Best Publication's latest edition Key Rating Guide.

		(Minimum Limits)
General Liability*	Each Occurrence	\$1,000,000
	General Aggregate	\$2,000,000
	Products/ Completed Operations Aggregate	\$2,000,000
Auto Liability*	Combined Single Limit	
	Each Accident	\$1,000,000
Umbrella* (Excess Liability)	Each Occurrence	\$3,000,000
	Aggregate	\$3,000,000

\*The insurance shall cover the Bidder and all of its agents, employees and sub-contractors and other providers of services and shall name the **Town and the Board of Education their employees and agents and the Capital Region Education Council (CREC)**. Coverage is to be provided on a primary, noncontributory basis. Waiver of Subrogation is to be included. **These requirements shall be clearly stated in the remarks section on the Bidders Certificate of Insurance.**

If any policy is written on a "Claims Made" basis, the policy must be continually renewed for a minimum of two (2) years from the completion date of this contract. If the policy is replaced and/or the retroactive date is changed, then the expiring policy must be endorsed to extend the reporting period for claims for the policy in effect during the contract for two (2) years from the completion date.

Workers' Compensation and Employers' Liability	WC Statutory Limits	
	EL Each Accident	\$100,000
	EL Disease Each Employee	\$100,000
	EL Disease Policy Limit	\$500,000

Original, completed Certificates of Insurance must be presented to the Town of Glastonbury prior to purchase order/ contract issuance. Vendor agrees to provide replacement/renewal certificates at least 60 days prior to the expiration of the policy.

**Indemnification**

To the fullest extent permitted by law, the Bidder shall indemnify and hold harmless the Town of Glastonbury and the Board of Education and its consultants, agents, and employees and CREC from and against all claims, damages, losses and expenses, direct, indirect, or consequential (including but not limited to fees and charges of engineers, attorneys and other professionals, and court and arbitration costs) to the extent arising out of or resulting from the performance of the Bidder's work, provided that such claim, damage, loss or expense is caused in whole or in part by any negligent act or omission by the Bidder, or breach of its obligations herein or by any person or organization directly or indirectly employed or engaged by the Bidder to perform or furnish either of the services, or anyone for whose acts the Bidder may be liable.

END OF SECTION

THIS PAGE INTENTIONALLY LEFT BLANK

# QUOTATION / BID PROPOSAL FORM

Quotation /Bid from \_\_\_\_\_  
(Firm Name)

\_\_\_\_\_  
(Firm Address)

\_\_\_\_\_  
(Date)

**To:** Town of Glastonbury  
Purchasing  
2155 Main Street, Second Level  
Glastonbury, Connecticut 06033  
Attn: Mary Visone, Purchasing Agent

**Re:** Bid for  
Moveable Equipment  
Glastonbury East Hartford Elementary  
Magnet School  
95 Oak Street  
Glastonbury, Connecticut  
STATE PROJECT NO. 054-0095 MAG/N/PS  
Phase 3 of 4  
GL-2011-04/BP-118

All bids shall include scope as further defined in the Contract Documents. Include both unit pricing and lump sum bid amount in the appropriate sections listed below. This project is tax exempt. A tax exemption certificate will be issued to the awarded contractor and material suppliers after a ward.

The undersigned proposes and agrees to provide Moveable Equipment for Glastonbury East Hartford Elementary Magnet School, 95 Oak Street Glastonbury, Connecticut required by and in strict accordance with the Contract Documents, dated **September 26, 2011** prepared by Fletcher-Thompson, Inc., herein for all work; including all addenda issued prior to opening of bids, for the unit prices as follows:

CODE	ITEM	MANUFACTURER	STYLE / MODEL	SUBSTITUTION	QTY.	UNIT PRICE (\$)	TOTAL (\$)	Substitution check if yes
A-001	Wastebasket	Rubbermaid	2956	<input type="checkbox"/>	68	<input type="checkbox"/>	<input type="checkbox"/>	<input type="checkbox"/>
A-002	Classroom Flag	School Specialty	1303566-030	<input type="checkbox"/>	30	<input type="checkbox"/>	<input type="checkbox"/>	<input type="checkbox"/>
A-003	USA Flag on Pole	School Specialty	603570-030	<input type="checkbox"/>	1	<input type="checkbox"/>	<input type="checkbox"/>	<input type="checkbox"/>
A-004	CT Flag on Pole	CVS Flags	Z02070104028P	<input type="checkbox"/>	1	<input type="checkbox"/>	<input type="checkbox"/>	<input type="checkbox"/>
A-005	Large Garbage	Rubbermaid	9W27-27 GY	<input type="checkbox"/>	4	<input type="checkbox"/>	<input type="checkbox"/>	<input type="checkbox"/>
A-006	USA Flag Exterior	CVS Flags	Z01006001	<input type="checkbox"/>	1	<input type="checkbox"/>	<input type="checkbox"/>	<input type="checkbox"/>
A-007	CT Exterior Flag	CVS Flags	Z02070105001	<input type="checkbox"/>	1	<input type="checkbox"/>	<input type="checkbox"/>	<input type="checkbox"/>
A-008	Pencil Sharpener	Stanley Bostitch	EPS8HD-BLK	<input type="checkbox"/>	33	<input type="checkbox"/>	<input type="checkbox"/>	<input type="checkbox"/>
A-009	Pre K & K Rug	School Specialty	334729-030	<input type="checkbox"/>	6	<input type="checkbox"/>	<input type="checkbox"/>	<input type="checkbox"/>

Glastonbury East Hartford  
Elementary Magnet  
School 95 Oak Street  
Glastonbury Connecticut

H090230  
054-0095 MAG/N/PS- Phase 3 of 4  
00410 - 1

September 26, 2011  
Quotation / Bid  
Proposal Form

CODE	ITEM	MANUFACTURER	STYLE / MODEL	SUBSTITUTION	QTY.	UNIT PRICE (\$)	TOTAL (\$)	Substitution check if yes
A-010	1st Grade Rug	Lakeshore	GG594	<input type="checkbox"/>	3	<input type="checkbox"/>	<input type="checkbox"/>	<input type="checkbox"/>
A-011	2nd Grade Rug	Kidcarpet	CK1412	<input type="checkbox"/>	3	<input type="checkbox"/>	<input type="checkbox"/>	<input type="checkbox"/>
A-012	3rd Grade Rug	School Specialty	509375	<input type="checkbox"/>	3	<input type="checkbox"/>	<input type="checkbox"/>	<input type="checkbox"/>
A-013	4th Grade Rug	Kidcarpet	CK1412	<input type="checkbox"/>	3	<input type="checkbox"/>	<input type="checkbox"/>	<input type="checkbox"/>
A-014	5th Grade Rug	Kidcarpet	CK1412	<input type="checkbox"/>	3	<input type="checkbox"/>	<input type="checkbox"/>	<input type="checkbox"/>
A-015	Japanese Rug	Lakeshore	GG594	<input type="checkbox"/>	1	<input type="checkbox"/>	<input type="checkbox"/>	<input type="checkbox"/>
A-017	Spec Ed Rug	Kidcarpet	CK4108	<input type="checkbox"/>	1	<input type="checkbox"/>	<input type="checkbox"/>	<input type="checkbox"/>
A-018	Folder & Tray Cubby Mail Slots	School Specialty	265341-030	<input type="checkbox"/>	22	<input type="checkbox"/>	<input type="checkbox"/>	<input type="checkbox"/>
A-019	Wheasel	Best-Rite	BES-759 PROM	<input type="checkbox"/>	27	<input type="checkbox"/>	<input type="checkbox"/>	<input type="checkbox"/>
A-020	1/2 Nursery Block Set	Community Playthings	B405	<input type="checkbox"/>	6	<input type="checkbox"/>	<input type="checkbox"/>	<input type="checkbox"/>
A-021	Woodcrest Kitchen Set of 4	Community Playthings	C360	<input type="checkbox"/>	3	<input type="checkbox"/>	<input type="checkbox"/>	<input type="checkbox"/>
A-022	Dress Up Unit	Community Playthings	C705	<input type="checkbox"/>	3	<input type="checkbox"/>	<input type="checkbox"/>	<input type="checkbox"/>
A-023	Groupwork Screen	Turnstone	TS4S	<input type="checkbox"/>	10	<input type="checkbox"/>	<input type="checkbox"/>	<input type="checkbox"/>
A-024	Paper Roll Cutter	School Specialty	009129	<input type="checkbox"/>	1	<input type="checkbox"/>	<input type="checkbox"/>	<input type="checkbox"/>
A-025	Self Healing Mat	School Specialty- Dahle Vantage	409207	<input type="checkbox"/>	1	<input type="checkbox"/>	<input type="checkbox"/>	<input type="checkbox"/>
A-026	Light Tracer	School Specialty- Artograph	335062	<input type="checkbox"/>	6	<input type="checkbox"/>	<input type="checkbox"/>	<input type="checkbox"/>
A-027	Wood Easel	School Specialty- Lobo Easel	245435	<input type="checkbox"/>	1	<input type="checkbox"/>	<input type="checkbox"/>	<input type="checkbox"/>
A-028	Plastic Art Cart	School Specialty- Rubbermaid	034256	<input type="checkbox"/>	1	<input type="checkbox"/>	<input type="checkbox"/>	<input type="checkbox"/>
A-029	Ware Cart	School Specialty- Debcor	423155	<input type="checkbox"/>	1	<input type="checkbox"/>	<input type="checkbox"/>	<input type="checkbox"/>
A-030	Kiln Shelf	School Specialty- Skutt Furniture Kits for Kilns	460262	<input type="checkbox"/>	1	<input type="checkbox"/>	<input type="checkbox"/>	<input type="checkbox"/>
A-031	Art Display Frames	Displays N Frames	Acrylic Wall Pho	<input type="checkbox"/>	50	<input type="checkbox"/>	<input type="checkbox"/>	<input type="checkbox"/>

CODE	ITEM	MANUFACTURER	STYLE / MODEL	SUBSTITUTION	QTY.	UNIT PRICE (\$)	TOTAL (\$)	Substitution check if yes
A-032	Storage Container w/ Lid	School Specialty	357084	<input type="checkbox"/>	6	<input type="checkbox"/>	<input type="checkbox"/>	<input type="checkbox"/>
A-033	Storage Bins	School Specialty-Akro-Mills	1308003	<input type="checkbox"/>	24	<input type="checkbox"/>	<input type="checkbox"/>	<input type="checkbox"/>
A-034	Storage Container w/ Lid	School Specialty-Rubbermaid Square Space Saving	403401- contain	<input type="checkbox"/>	6	<input type="checkbox"/>	<input type="checkbox"/>	<input type="checkbox"/>
A-035	Storage Container w/ Lid	Rubbermaid	403395 - contai	<input type="checkbox"/>	6	<input type="checkbox"/>	<input type="checkbox"/>	<input type="checkbox"/>
A-036	Equipment Cart	Brodart School Supplies & Furnishings	84 521-84 524 0	<input type="checkbox"/>	1	<input type="checkbox"/>	<input type="checkbox"/>	<input type="checkbox"/>
A-037	Music Stand	Cascio Interstate Music	Manhasset Mod	<input type="checkbox"/>	13	<input type="checkbox"/>	<input type="checkbox"/>	<input type="checkbox"/>
A-044	Music Board	Wenger Corp	Lesson Works B	<input type="checkbox"/>	1	<input type="checkbox"/>	<input type="checkbox"/>	<input type="checkbox"/>
A-045	Rotary Trimmer	Brodart School Supplies & Furnishings - Swingline	42 318 001	<input type="checkbox"/>	1	<input type="checkbox"/>	<input type="checkbox"/>	<input type="checkbox"/>
A-046	Collapsible Cart	Brodart School Supplies & Furnishings- Pack-n-Roll	49615001	<input type="checkbox"/>	1	<input type="checkbox"/>	<input type="checkbox"/>	<input type="checkbox"/>
A-047	Globe	Brodart School Supplies & Furnishings	82 867 001	<input type="checkbox"/>	1	<input type="checkbox"/>	<input type="checkbox"/>	<input type="checkbox"/>
A-048	Constellation Globe	Brodart School Supplies & Furnishings- Replogle	84084101	<input type="checkbox"/>	1	<input type="checkbox"/>	<input type="checkbox"/>	<input type="checkbox"/>
A-050	Binding Machine	Demco- GBC	C110	<input type="checkbox"/>	1	<input type="checkbox"/>	<input type="checkbox"/>	<input type="checkbox"/>
A-051	Long Range Stapler	Demco - Bostitch	P163-4068	<input type="checkbox"/>	1	<input type="checkbox"/>	<input type="checkbox"/>	<input type="checkbox"/>
A-052	Heavy Duty Stapler	Demco -Bostitch	P163-4050	<input type="checkbox"/>	1	<input type="checkbox"/>	<input type="checkbox"/>	<input type="checkbox"/>
A-053	Die Cutter	Demco-AccuCut	P164-0237	<input type="checkbox"/>	3	<input type="checkbox"/>	<input type="checkbox"/>	<input type="checkbox"/>
A-056	Bulletin Board	Claridge	800 Series	<input type="checkbox"/>	3	<input type="checkbox"/>	<input type="checkbox"/>	<input type="checkbox"/>



CODE	ITEM	MANUFACTURER	STYLE / MODEL	SUBSTITUTION	QTY.	UNIT PRICE (\$)	TOTAL (\$)	Substitution check if yes
A-057	Totes	Sportime	086505	<input type="checkbox"/>	12	<input type="checkbox"/>	<input type="checkbox"/>	<input type="checkbox"/>
A-058	Ball Racks	Sportime	1281641	<input type="checkbox"/>	1	<input type="checkbox"/>	<input type="checkbox"/>	<input type="checkbox"/>
A-059	Trash Containers Corridor	RPI	RR10-25	<input type="checkbox"/>	2	<input type="checkbox"/>	<input type="checkbox"/>	<input type="checkbox"/>
A-060	55 Gallon Brute Trash Can w/ Dolly	Rubbermaid	2655-Brute cont	<input type="checkbox"/>	13	<input type="checkbox"/>	<input type="checkbox"/>	<input type="checkbox"/>
A-061	Recycle Container	Rubbermaid	2956-73	<input type="checkbox"/>	46	<input type="checkbox"/>	<input type="checkbox"/>	<input type="checkbox"/>
A-062	Mop Buckets	Rubbermaid	757688YW	<input type="checkbox"/>	4	<input type="checkbox"/>	<input type="checkbox"/>	<input type="checkbox"/>
A-063	Mini-White Boards	Best-Rite	BS15553	<input type="checkbox"/>	612	<input type="checkbox"/>	<input type="checkbox"/>	<input type="checkbox"/>
A-064	Map Pack 1-Pre K-K	Nystromnet	11ELS	<input type="checkbox"/>	6	<input type="checkbox"/>	<input type="checkbox"/>	<input type="checkbox"/>
A-065	Map Pack 2-Grades 1+2	Nystromnet	11NS02	<input type="checkbox"/>	7	<input type="checkbox"/>	<input type="checkbox"/>	<input type="checkbox"/>
A-066	Map Pack 3-Grades 3+4	Nystromnet	11MR	<input type="checkbox"/>	6	<input type="checkbox"/>	<input type="checkbox"/>	<input type="checkbox"/>
A-067	Map Pack 4-Grade 5	Nystromnet	11PL	<input type="checkbox"/>	6	<input type="checkbox"/>	<input type="checkbox"/>	<input type="checkbox"/>
A-068	Child Cot	Mahar	MHR-500T	<input type="checkbox"/>	60	<input type="checkbox"/>	<input type="checkbox"/>	<input type="checkbox"/>
A-070	Bread Slicing Knife	Dexter	S46910	<input type="checkbox"/>	2	<input type="checkbox"/>	<input type="checkbox"/>	<input type="checkbox"/>
A-071	French Cook Knife	Dexter	S-145-10	<input type="checkbox"/>	2	<input type="checkbox"/>	<input type="checkbox"/>	<input type="checkbox"/>
A-072	Cake Turner Blade	Dexter	S286-8	<input type="checkbox"/>	2	<input type="checkbox"/>	<input type="checkbox"/>	<input type="checkbox"/>
A-073	Hamburger Turner	Dexter	S286-4	<input type="checkbox"/>	2	<input type="checkbox"/>	<input type="checkbox"/>	<input type="checkbox"/>
A-074	Sandwich Spreader	Dexter	S173	<input type="checkbox"/>	4	<input type="checkbox"/>	<input type="checkbox"/>	<input type="checkbox"/>
A-075	Paring Knife	Dexter	S104	<input type="checkbox"/>	6	<input type="checkbox"/>	<input type="checkbox"/>	<input type="checkbox"/>
A-076	Vegetable Peeler	Dexter	91500	<input type="checkbox"/>	3	<input type="checkbox"/>	<input type="checkbox"/>	<input type="checkbox"/>
A-077	All Purpose Disher 1	Vollrath	47141	<input type="checkbox"/>	4	<input type="checkbox"/>	<input type="checkbox"/>	<input type="checkbox"/>
A-078	All Purpose Disher 2	Vollrath	47142	<input type="checkbox"/>	2	<input type="checkbox"/>	<input type="checkbox"/>	<input type="checkbox"/>
A-079	All Purpose Disher 3	Vollrath	47143	<input type="checkbox"/>	2	<input type="checkbox"/>	<input type="checkbox"/>	<input type="checkbox"/>

CODE	ITEM	MANUFACTURER	STYLE / MODEL	SUBSTITUTION	QTY.	UNIT PRICE (\$)	TOTAL (\$)	Substitution check if yes
A-080	All Purpose Dish 4	Vollrath	47145	<input type="checkbox"/>	2	<input type="checkbox"/>	<input type="checkbox"/>	<input type="checkbox"/>
A-081	SS Solid Basting Spoon	Vollrath	64400	<input type="checkbox"/>	3	<input type="checkbox"/>	<input type="checkbox"/>	<input type="checkbox"/>
A-082	Slotted Basting Spoon	Vollrath	64405	<input type="checkbox"/>	3	<input type="checkbox"/>	<input type="checkbox"/>	<input type="checkbox"/>
A-083	Perforated Basting spoon	Vollrath	64401	<input type="checkbox"/>	3	<input type="checkbox"/>	<input type="checkbox"/>	<input type="checkbox"/>
A-084	Ladle 1	Vollrath	58620	<input type="checkbox"/>	4	<input type="checkbox"/>	<input type="checkbox"/>	<input type="checkbox"/>
A-085	Ladle 2	Vollrath	58460	<input type="checkbox"/>	2	<input type="checkbox"/>	<input type="checkbox"/>	<input type="checkbox"/>
A-086	Ladle 3	Vollrath	58480	<input type="checkbox"/>	2	<input type="checkbox"/>	<input type="checkbox"/>	<input type="checkbox"/>
A-087	Cake Turner	Vollrath	46934	<input type="checkbox"/>	1	<input type="checkbox"/>	<input type="checkbox"/>	<input type="checkbox"/>
A-088	Funnel 1	Vollrath	84760	<input type="checkbox"/>	1	<input type="checkbox"/>	<input type="checkbox"/>	<input type="checkbox"/>
A-089	Funnel 2	Vollrath	84740	<input type="checkbox"/>	1	<input type="checkbox"/>	<input type="checkbox"/>	<input type="checkbox"/>
A-090	Scoop	Vollrath	46892	<input type="checkbox"/>	1	<input type="checkbox"/>	<input type="checkbox"/>	<input type="checkbox"/>
A-091	Measure Cap 1	Vollrath	68352	<input type="checkbox"/>	2	<input type="checkbox"/>	<input type="checkbox"/>	<input type="checkbox"/>
A-092	Measure Cap 2	Vollrath	68296	<input type="checkbox"/>	2	<input type="checkbox"/>	<input type="checkbox"/>	<input type="checkbox"/>
A-093	Measure Cap 3	Vollrath	68297	<input type="checkbox"/>	1	<input type="checkbox"/>	<input type="checkbox"/>	<input type="checkbox"/>
A-094	Steel Blade	Dexter	A12R	<input type="checkbox"/>	1	<input type="checkbox"/>	<input type="checkbox"/>	<input type="checkbox"/>
A-095	Steam Table Pan 1	Vollrath	3002-2	<input type="checkbox"/>	12	<input type="checkbox"/>	<input type="checkbox"/>	<input type="checkbox"/>
A-096	Steam Table Pan 2	Vollrath	3004-2	<input type="checkbox"/>	12	<input type="checkbox"/>	<input type="checkbox"/>	<input type="checkbox"/>
A-097	Steam Table Pan 3	Vollrath	3006-2	<input type="checkbox"/>	6	<input type="checkbox"/>	<input type="checkbox"/>	<input type="checkbox"/>
A-098	Steam Table Pan 4	Vollrath	3004-3	<input type="checkbox"/>	4	<input type="checkbox"/>	<input type="checkbox"/>	<input type="checkbox"/>
A-099	Steam Table Pan 5	Vollrath	3002-3	<input type="checkbox"/>	3	<input type="checkbox"/>	<input type="checkbox"/>	<input type="checkbox"/>
A-100	Steam Table Pan Cover 1	Vollrath	77250	<input type="checkbox"/>	6	<input type="checkbox"/>	<input type="checkbox"/>	<input type="checkbox"/>
A-101	Steam Table Pan Cover 2	Vollrath	77510	<input type="checkbox"/>	6	<input type="checkbox"/>	<input type="checkbox"/>	<input type="checkbox"/>
A-102	Steam Table Pan 6	Vollrath	3024-2	<input type="checkbox"/>	6	<input type="checkbox"/>	<input type="checkbox"/>	<input type="checkbox"/>
A-103	Steam Table Pan 7	Vollrath	3026-2	<input type="checkbox"/>	3	<input type="checkbox"/>	<input type="checkbox"/>	<input type="checkbox"/>

CODE	ITEM	MANUFACTURER	STYLE / MODEL	SUBSTITUTION	QTY.	UNIT PRICE (\$)	TOTAL (\$)	Substitution check if yes
A-104	Steam Table Pan Cover 3	Vollrath	75120	<input type="checkbox"/>	6	<input type="checkbox"/>	<input type="checkbox"/>	<input type="checkbox"/>
A-105	Stream Table Pan 8	Vollrath	3034-2	<input type="checkbox"/>	2	<input type="checkbox"/>	<input type="checkbox"/>	<input type="checkbox"/>
A-106	Steam Table Pan 9	Vollrath	3036-2	<input type="checkbox"/>	2	<input type="checkbox"/>	<input type="checkbox"/>	<input type="checkbox"/>
A-107	Steam Table Pan Cover 4	Vollrath	75130	<input type="checkbox"/>	4	<input type="checkbox"/>	<input type="checkbox"/>	<input type="checkbox"/>
A-108	Steam Table Pan 10	Vollrath	3064-2	<input type="checkbox"/>	10	<input type="checkbox"/>	<input type="checkbox"/>	<input type="checkbox"/>
A-109	Tongs 1	Vollrath	47309	<input type="checkbox"/>	6	<input type="checkbox"/>	<input type="checkbox"/>	<input type="checkbox"/>
A-110	Tongs 2	Vollrath	47312	<input type="checkbox"/>	3	<input type="checkbox"/>	<input type="checkbox"/>	<input type="checkbox"/>
A-111	Piano Whips 1	Vollrath	47032	<input type="checkbox"/>	2	<input type="checkbox"/>	<input type="checkbox"/>	<input type="checkbox"/>
A-112	Piano Whips 2	Vollrath	47036	<input type="checkbox"/>	2	<input type="checkbox"/>	<input type="checkbox"/>	<input type="checkbox"/>
A-113	Mixing Bowl 1	Vollrath	69130	<input type="checkbox"/>	2	<input type="checkbox"/>	<input type="checkbox"/>	<input type="checkbox"/>
A-114	Mixing bowl 2	Vollrath	69080	<input type="checkbox"/>	2	<input type="checkbox"/>	<input type="checkbox"/>	<input type="checkbox"/>
A-115	Colander	Vollrath	68350	<input type="checkbox"/>	2	<input type="checkbox"/>	<input type="checkbox"/>	<input type="checkbox"/>
A-116	Sauce Pan 1	Vollrath-Arkadia	7344	<input type="checkbox"/>	2	<input type="checkbox"/>	<input type="checkbox"/>	<input type="checkbox"/>
A-117	Sauce Pan 2	Wear-Ever	4348 1/2	<input type="checkbox"/>	2	<input type="checkbox"/>	<input type="checkbox"/>	<input type="checkbox"/>
A-118	Sheet Pans	Vollrath	68386	<input type="checkbox"/>	36	<input type="checkbox"/>	<input type="checkbox"/>	<input type="checkbox"/>
A-119	Cutting Boards	Vollrath	5200340, 52003	<input type="checkbox"/>	5	<input type="checkbox"/>	<input type="checkbox"/>	<input type="checkbox"/>
A-120	Electric Can Opener	Superior Specialty Co.	270	<input type="checkbox"/>	1	<input type="checkbox"/>	<input type="checkbox"/>	<input type="checkbox"/>
A-121	Thermometers	Calico Industries-Comark Instruments	27RFT2A	<input type="checkbox"/>	8	<input type="checkbox"/>	<input type="checkbox"/>	<input type="checkbox"/>
A-122	Disher 5	Vollrath	47140	<input type="checkbox"/>	2	<input type="checkbox"/>	<input type="checkbox"/>	<input type="checkbox"/>
A-123	Ladle 4	Vollrath	58440	<input type="checkbox"/>	2	<input type="checkbox"/>	<input type="checkbox"/>	<input type="checkbox"/>
A-124	Basting Brush	Vollrath	458	<input type="checkbox"/>	3	<input type="checkbox"/>	<input type="checkbox"/>	<input type="checkbox"/>
A-125	Rubber Spatulas	Vollrath	52023	<input type="checkbox"/>	3	<input type="checkbox"/>	<input type="checkbox"/>	<input type="checkbox"/>
A-126	Pizza Cutters	Dexter	P94ZZA-4	<input type="checkbox"/>	4	<input type="checkbox"/>	<input type="checkbox"/>	<input type="checkbox"/>
A-127	Tongs 3	Royal Industries	ROY PCT 9	<input type="checkbox"/>	12	<input type="checkbox"/>	<input type="checkbox"/>	<input type="checkbox"/>

CODE	ITEM	MANUFACTURER	STYLE / MODEL	SUBSTITUTION	QTY.	UNIT PRICE (\$)	TOTAL (\$)	Substitution check if yes
A-128	Pocket Thermometers	Calico Industries - Taylor Precision Products	2760921	<input type="checkbox"/>	4	<input type="checkbox"/>	<input type="checkbox"/>	<input type="checkbox"/>
A-129	Grated Cheese Shakers	Vollrath	674	<input type="checkbox"/>	6	<input type="checkbox"/>	<input type="checkbox"/>	<input type="checkbox"/>
A-130	Condiment Containers/ Squeeze Bottles	Vollrath	62061 & 52062	<input type="checkbox"/>	12	<input type="checkbox"/>	<input type="checkbox"/>	<input type="checkbox"/>
A-131	Saddle Bag Dispensers	Hubert	63496	<input type="checkbox"/>	4	<input type="checkbox"/>	<input type="checkbox"/>	<input type="checkbox"/>
A-132	Can Rack	Calico Industries	57CSR9	<input type="checkbox"/>	1	<input type="checkbox"/>	<input type="checkbox"/>	<input type="checkbox"/>
A-133	Utility Carts	RubberMaid	4091	<input type="checkbox"/>	2	<input type="checkbox"/>	<input type="checkbox"/>	<input type="checkbox"/>
A-134	Open Sided Sheet Pan Rack	KaTom Restaurant Supplies Inc. - Doyon Baking Equipment	013-1811SL	<input type="checkbox"/>	3	<input type="checkbox"/>	<input type="checkbox"/>	<input type="checkbox"/>
A-135	Portion Server 1	Vollrath	6412445	<input type="checkbox"/>	4	<input type="checkbox"/>	<input type="checkbox"/>	<input type="checkbox"/>
A-136	Portion Server 2	Vollrath	6422445	<input type="checkbox"/>	4	<input type="checkbox"/>	<input type="checkbox"/>	<input type="checkbox"/>
A-137	Portion Server 3	Vollrath	6412655	<input type="checkbox"/>	4	<input type="checkbox"/>	<input type="checkbox"/>	<input type="checkbox"/>
A-138	Portion Server 4	Vollrath	6422655	<input type="checkbox"/>	4	<input type="checkbox"/>	<input type="checkbox"/>	<input type="checkbox"/>
A-139	Portion Server 5	Vollrath	6412865	<input type="checkbox"/>	4	<input type="checkbox"/>	<input type="checkbox"/>	<input type="checkbox"/>
A-140	Portion Server 6	Vollrath	6422865	<input type="checkbox"/>	4	<input type="checkbox"/>	<input type="checkbox"/>	<input type="checkbox"/>
A-141	Calendar White Board	MagnaLite	Monthly Planni	<input type="checkbox"/>	1	<input type="checkbox"/>	<input type="checkbox"/>	<input type="checkbox"/>
A-142	Foot Stool with Handle	School Health	24307	<input type="checkbox"/>	1	<input type="checkbox"/>	<input type="checkbox"/>	<input type="checkbox"/>
A-143	White Board	Best-Rite	ABC Magnetic	<input type="checkbox"/>	1	<input type="checkbox"/>	<input type="checkbox"/>	<input type="checkbox"/>
A-144	Large Paper Cutter	School Specialty-Quartet	032703	<input type="checkbox"/>	1	<input type="checkbox"/>	<input type="checkbox"/>	<input type="checkbox"/>
A-145	Large Book Baskets	Sterilite	084321	<input type="checkbox"/>	300	<input type="checkbox"/>	<input type="checkbox"/>	<input type="checkbox"/>
A-146	Medium Book Basket	Sterilite	084320	<input type="checkbox"/>	288	<input type="checkbox"/>	<input type="checkbox"/>	<input type="checkbox"/>

CODE	ITEM	MANUFACTURER	STYLE / MODEL	SUBSTITUTION	QTY.	UNIT PRICE (\$)	TOTAL (\$)	Substitution check if yes
A-147	Sheet Pans for Camcart	Advance Tabco	18A26	<input type="checkbox"/>	48	<input type="checkbox"/>	<input type="checkbox"/>	<input type="checkbox"/>
CH-001	Pre K Chairs Xtra Small	KI	IW410	<input type="checkbox"/>	105	<input type="checkbox"/>	<input type="checkbox"/>	<input type="checkbox"/>
CH-002	K + 1st Grade Small Chairs	KI	IWC13	<input type="checkbox"/>	246	<input type="checkbox"/>	<input type="checkbox"/>	<input type="checkbox"/>
CH-003	2nd + 3rd Grade Medium Chairs	KI	IWC15	<input type="checkbox"/>	224	<input type="checkbox"/>	<input type="checkbox"/>	<input type="checkbox"/>
CH-004	4 th + 5th Grade Large Chairs	KI	IWC18	<input type="checkbox"/>	316	<input type="checkbox"/>	<input type="checkbox"/>	<input type="checkbox"/>
CH-005	Music Chair	Wenger Corp	Student Chair W	<input type="checkbox"/>	23	<input type="checkbox"/>	<input type="checkbox"/>	<input type="checkbox"/>
CH-006	Teacher Chair	Sit On It	Focus 5623 E A9	<input type="checkbox"/>	48	<input type="checkbox"/>	<input type="checkbox"/>	<input type="checkbox"/>
CH-007	Teacher Reading Chair	Sit On It	Social- Armless	<input type="checkbox"/>	105	<input type="checkbox"/>	<input type="checkbox"/>	<input type="checkbox"/>
CH-008	Waiting Chair	First Office	BALANCE Side C	<input type="checkbox"/>	12	<input type="checkbox"/>	<input type="checkbox"/>	<input type="checkbox"/>
CH-009	Stack Chair	KI	Matrix Stack Ch	<input type="checkbox"/>	300	<input type="checkbox"/>	<input type="checkbox"/>	<input type="checkbox"/>
CH-010	Conference Chairs	Focus Work	Mid-Back Uphol	<input type="checkbox"/>	15	<input type="checkbox"/>	<input type="checkbox"/>	<input type="checkbox"/>
CH-011	Couch	KI	Sela Sofa w/ Wo	<input type="checkbox"/>	1	<input type="checkbox"/>	<input type="checkbox"/>	<input type="checkbox"/>
CH-012	Arm Chairs	KI	SELA Lounge Ch	<input type="checkbox"/>	2	<input type="checkbox"/>	<input type="checkbox"/>	<input type="checkbox"/>
CH-013	Task-Stool	Sit On it	Focus Stool Hei	<input type="checkbox"/>	1	<input type="checkbox"/>	<input type="checkbox"/>	<input type="checkbox"/>
CH-014	Classroom Stools	KI	618W-600 Serie	<input type="checkbox"/>	60	<input type="checkbox"/>	<input type="checkbox"/>	<input type="checkbox"/>
CH-015	Recovery Couch	Clinton Industries	3620-27	<input type="checkbox"/>	2	<input type="checkbox"/>	<input type="checkbox"/>	<input type="checkbox"/>
CH-016	Exam Stool	Clinton Industries	2175	<input type="checkbox"/>	1	<input type="checkbox"/>	<input type="checkbox"/>	<input type="checkbox"/>
CH-017	Immersive Theater Chairs	Avarte	Funktus 544 - C	<input type="checkbox"/>	110	<input type="checkbox"/>	<input type="checkbox"/>	<input type="checkbox"/>
CH-018	Library Chairs	TMC Furniture	SFLC11315F- Fa	<input type="checkbox"/>	35	<input type="checkbox"/>	<input type="checkbox"/>	<input type="checkbox"/>
CH-019	Library Soft Seating 1	Allermuir	Pebble-A620	<input type="checkbox"/>	8	<input type="checkbox"/>	<input type="checkbox"/>	<input type="checkbox"/>
CH-020	Library Soft Seating 2	Allermuir	Pebble - A621 (s	<input type="checkbox"/>	8	<input type="checkbox"/>	<input type="checkbox"/>	<input type="checkbox"/>
CH-021	Stool	Hertz Furniture- Troutman Chair	TRS-18N	<input type="checkbox"/>	30	<input type="checkbox"/>	<input type="checkbox"/>	<input type="checkbox"/>

CODE	ITEM	MANUFACTURER	STYLE / MODEL	SUBSTITUTION	QTY.	UNIT PRICE (\$)	TOTAL (\$)	Substitution check if yes
D-001	Student Desk w/ Book Basket Box	KI	IWDCH/A: Intell	<input type="checkbox"/>	303	<input type="checkbox"/>	<input type="checkbox"/>	<input type="checkbox"/>
D-002	ADA Compliant Student Desk	KI	EDADA - Intellec	<input type="checkbox"/>	15	<input type="checkbox"/>	<input type="checkbox"/>	<input type="checkbox"/>
D-003L	Teacher's Classroom Desk	Vanerum Stelter	Teacher's Desk	<input type="checkbox"/>	16	<input type="checkbox"/>	<input type="checkbox"/>	<input type="checkbox"/>
D-003R	Teacher's Classroom Desk	Vanerum Stelter	Teacher's Desk	<input type="checkbox"/>	15	<input type="checkbox"/>	<input type="checkbox"/>	<input type="checkbox"/>
D-004	Small Private Office Desk	First Office	Vegas- Double P	<input type="checkbox"/>	8	<input type="checkbox"/>	<input type="checkbox"/>	<input type="checkbox"/>
D-005	Large Private Office Desk	First Office	Left U- Desk wit	<input type="checkbox"/>	2	<input type="checkbox"/>	<input type="checkbox"/>	<input type="checkbox"/>
D-006	Medium Private Office Desk	First Office	Vegas L-Shaped	<input type="checkbox"/>	2	<input type="checkbox"/>	<input type="checkbox"/>	<input type="checkbox"/>
D-007	Small Private Office Desk 2	Hon	38180	<input type="checkbox"/>	2	<input type="checkbox"/>	<input type="checkbox"/>	<input type="checkbox"/>
D-008	Proof Mobile Desk	Vanerum Stelter	Proof Double Pe	<input type="checkbox"/>	1	<input type="checkbox"/>	<input type="checkbox"/>	<input type="checkbox"/>
E-001	Keyboards	Roland	Juno-Di	<input type="checkbox"/>	1	<input type="checkbox"/>	<input type="checkbox"/>	<input type="checkbox"/>
E-002	RMP	Roland	BA-55	<input type="checkbox"/>	1	<input type="checkbox"/>	<input type="checkbox"/>	<input type="checkbox"/>
E-003	Orff Instruments	West Music	203815	<input type="checkbox"/>	1	<input type="checkbox"/>	<input type="checkbox"/>	<input type="checkbox"/>
E-004	Music Mallets	West Music	256121	<input type="checkbox"/>	1	<input type="checkbox"/>	<input type="checkbox"/>	<input type="checkbox"/>
E-005	Autoharp	West Music - Oscar Schmidt	300002	<input type="checkbox"/>	1	<input type="checkbox"/>	<input type="checkbox"/>	<input type="checkbox"/>
E-006	Block w/ Mallet	West Music	201634	<input type="checkbox"/>	1	<input type="checkbox"/>	<input type="checkbox"/>	<input type="checkbox"/>
E-007	Medium Wood Maracas	West Music	201014	<input type="checkbox"/>	1	<input type="checkbox"/>	<input type="checkbox"/>	<input type="checkbox"/>
E-008	Hand Bells	West Music	203763	<input type="checkbox"/>	1	<input type="checkbox"/>	<input type="checkbox"/>	<input type="checkbox"/>
E-009	Triangles	West Music	201548, 201549	<input type="checkbox"/>	1	<input type="checkbox"/>	<input type="checkbox"/>	<input type="checkbox"/>
E-010	Tambourine	West Music	201372	<input type="checkbox"/>	1	<input type="checkbox"/>	<input type="checkbox"/>	<input type="checkbox"/>
E-011	Tambourine	West Music-Remo	201436	<input type="checkbox"/>	1	<input type="checkbox"/>	<input type="checkbox"/>	<input type="checkbox"/>
E-012	Finger Cymbals	West Music-Basic Beat	BB732	<input type="checkbox"/>	1	<input type="checkbox"/>	<input type="checkbox"/>	<input type="checkbox"/>

CODE	ITEM	MANUFACTURER	STYLE / MODEL	SUBSTITUTION	QTY.	UNIT PRICE (\$)	TOTAL (\$)	Substitution check if yes
E-013	Wooden Guiro	West Music-Basic Beat	BB06	<input type="checkbox"/>	1	<input type="checkbox"/>	<input type="checkbox"/>	<input type="checkbox"/>
E-014	Sound Shapes	West Music-Remo	SS-1000-06	<input type="checkbox"/>	1	<input type="checkbox"/>	<input type="checkbox"/>	<input type="checkbox"/>
E-015	Kids Konga	West Music-Remo	200590	<input type="checkbox"/>	1	<input type="checkbox"/>	<input type="checkbox"/>	<input type="checkbox"/>
E-016	Kids Tubano	West Music-Remo	201578	<input type="checkbox"/>	1	<input type="checkbox"/>	<input type="checkbox"/>	<input type="checkbox"/>
E-017	Bean Bags	West Music	200266	<input type="checkbox"/>	1	<input type="checkbox"/>	<input type="checkbox"/>	<input type="checkbox"/>
E-018	5" Cymbals with Mallets	Music K-8 Marketplace	MP-HP200	<input type="checkbox"/>	1	<input type="checkbox"/>	<input type="checkbox"/>	<input type="checkbox"/>
E-019	Rhythm Stick Kit	Music K-8 Marketplace	MP-FR100	<input type="checkbox"/>	1	<input type="checkbox"/>	<input type="checkbox"/>	<input type="checkbox"/>
E-020	Eggz Shakers	Music K-8 Marketplace	MP-RT361	<input type="checkbox"/>	1	<input type="checkbox"/>	<input type="checkbox"/>	<input type="checkbox"/>
E-021	Upright Acoustic Piano with Bench	Yamaha	U3	<input type="checkbox"/>	1	<input type="checkbox"/>	<input type="checkbox"/>	<input type="checkbox"/>
E-022	Rice Cooker	Zojirushi	NP-HBC18	<input type="checkbox"/>	2	<input type="checkbox"/>	<input type="checkbox"/>	<input type="checkbox"/>
E-023	Water Heater	Zojirushi	CD-FAC22	<input type="checkbox"/>	2	<input type="checkbox"/>	<input type="checkbox"/>	<input type="checkbox"/>
E-024	Junior Basketballs	US Games-Voit Enduro	1335	<input type="checkbox"/>	25	<input type="checkbox"/>	<input type="checkbox"/>	<input type="checkbox"/>
E-025	Playground Balls	US Games- Voit Balls	1033472	<input type="checkbox"/>	4	<input type="checkbox"/>	<input type="checkbox"/>	<input type="checkbox"/>
E-026	Softtouch Hockey Sticks	Sportime	9007060112 &	<input type="checkbox"/>	1	<input type="checkbox"/>	<input type="checkbox"/>	<input type="checkbox"/>
E-027	Hockey Hotballs	Sportime- Shield	91282655	<input type="checkbox"/>	1	<input type="checkbox"/>	<input type="checkbox"/>	<input type="checkbox"/>
E-028	Uncoated Foam Balls	US Games-Voit	1181555	<input type="checkbox"/>	5	<input type="checkbox"/>	<input type="checkbox"/>	<input type="checkbox"/>
E-029	Rainbow Plastic Cones	Gym Closet	1887	<input type="checkbox"/>	8	<input type="checkbox"/>	<input type="checkbox"/>	<input type="checkbox"/>
E-030	Half Cones	Sportime	9006835	<input type="checkbox"/>	1	<input type="checkbox"/>	<input type="checkbox"/>	<input type="checkbox"/>
E-031	Orange Cones	Sportime	716170	<input type="checkbox"/>	30	<input type="checkbox"/>	<input type="checkbox"/>	<input type="checkbox"/>
E-032	Balance Board	US Games	1008135	<input type="checkbox"/>	7	<input type="checkbox"/>	<input type="checkbox"/>	<input type="checkbox"/>
E-033	Scrimmage Vests	US Games	C46Y	<input type="checkbox"/>	14	<input type="checkbox"/>	<input type="checkbox"/>	<input type="checkbox"/>
E-034	Volleyball Net	Volleyball USA	VB1350K	<input type="checkbox"/>	1	<input type="checkbox"/>	<input type="checkbox"/>	<input type="checkbox"/>

CODE	ITEM	MANUFACTURER	STYLE / MODEL	SUBSTITUTION	QTY.	UNIT PRICE (\$)	TOTAL (\$)	Substitution check if yes
E-035	Ball Inflator	School Specialty	087966	<input type="checkbox"/>	1	<input type="checkbox"/>	<input type="checkbox"/>	<input type="checkbox"/>
E-036	Poly Spot Markers	US Games	6059	<input type="checkbox"/>	1	<input type="checkbox"/>	<input type="checkbox"/>	<input type="checkbox"/>
E-037	Poly Spot Markers 9"	US Games	6058	<input type="checkbox"/>	2	<input type="checkbox"/>	<input type="checkbox"/>	<input type="checkbox"/>
E-038	Jump Rope x2 Dutch	US Games	17314	<input type="checkbox"/>	8	<input type="checkbox"/>	<input type="checkbox"/>	<input type="checkbox"/>
E-039	Jump ropes	US Games	17207	<input type="checkbox"/>	30	<input type="checkbox"/>	<input type="checkbox"/>	<input type="checkbox"/>
E-040	Chinese Jump Ropes	Sportime	029850112	<input type="checkbox"/>	2	<input type="checkbox"/>	<input type="checkbox"/>	<input type="checkbox"/>
E-041	Pulse Monitors	Gym Closet-Sportline Solo	6904	<input type="checkbox"/>	24	<input type="checkbox"/>	<input type="checkbox"/>	<input type="checkbox"/>
E-042	Pulse Monitors	Gym Closet-Biosig	1143	<input type="checkbox"/>	4	<input type="checkbox"/>	<input type="checkbox"/>	<input type="checkbox"/>
E-043	CD /Tape Player	Sportime - Califone	1320547	<input type="checkbox"/>	1	<input type="checkbox"/>	<input type="checkbox"/>	<input type="checkbox"/>
E-044	Voice Blaster	US Games	1162769	<input type="checkbox"/>	1	<input type="checkbox"/>	<input type="checkbox"/>	<input type="checkbox"/>
E-045	Mats-1	Sportime	1306559	<input type="checkbox"/>	2	<input type="checkbox"/>	<input type="checkbox"/>	<input type="checkbox"/>
E-046	Mats-2	US Games-GSC	1041569	<input type="checkbox"/>	14	<input type="checkbox"/>	<input type="checkbox"/>	<input type="checkbox"/>
E-047	Mats-3	US Games-GSC	1041712	<input type="checkbox"/>	1	<input type="checkbox"/>	<input type="checkbox"/>	<input type="checkbox"/>
E-048	Mat Cart	US Games	20023582	<input type="checkbox"/>	1	<input type="checkbox"/>	<input type="checkbox"/>	<input type="checkbox"/>
E-049	Pull Up Bars	Sportime	013117	<input type="checkbox"/>	2	<input type="checkbox"/>	<input type="checkbox"/>	<input type="checkbox"/>
E-050	Power Climbers	Sportime	7008729	<input type="checkbox"/>	1	<input type="checkbox"/>	<input type="checkbox"/>	<input type="checkbox"/>
E-051	Fish Tank Set Up 1	Exotic Fish and Corals	Various	<input type="checkbox"/>	1	<input type="checkbox"/>	<input type="checkbox"/>	<input type="checkbox"/>
E-052	Playground Balls	US Games	1233179	<input type="checkbox"/>	2	<input type="checkbox"/>	<input type="checkbox"/>	<input type="checkbox"/>
E-053	Basketballs	US Games-MacGregor	934021	<input type="checkbox"/>	9	<input type="checkbox"/>	<input type="checkbox"/>	<input type="checkbox"/>
E-054	Basketballs	US Games-MacGregor	934021	<input type="checkbox"/>	9	<input type="checkbox"/>	<input type="checkbox"/>	<input type="checkbox"/>
E-055	Basketballs	US Games-MacGregor	934021	<input type="checkbox"/>	9	<input type="checkbox"/>	<input type="checkbox"/>	<input type="checkbox"/>
E-056	Hula Hoops	US Games	02170- 36" & 02	<input type="checkbox"/>	10	<input type="checkbox"/>	<input type="checkbox"/>	<input type="checkbox"/>
E-057	Mesh Bags for Vests	Sportime	018556	<input type="checkbox"/>	1	<input type="checkbox"/>	<input type="checkbox"/>	<input type="checkbox"/>



CODE	ITEM	MANUFACTURER	STYLE / MODEL	SUBSTITUTION	QTY.	UNIT PRICE (\$)	TOTAL (\$)	Subsitution check if yes
E-058	Fish Tank Set Up 2	Exotic Fish and Corals	Varies	<input type="checkbox"/>	1	<input type="checkbox"/>	<input type="checkbox"/>	<input type="checkbox"/>
E-059	Nerf Footballs	US Games	44095	<input type="checkbox"/>	9	<input type="checkbox"/>	<input type="checkbox"/>	<input type="checkbox"/>
E-060	Outdoor Basketball Hoop Nets	Hoops Direct-Goal Sporting Goods	20731	<input type="checkbox"/>	2	<input type="checkbox"/>	<input type="checkbox"/>	<input type="checkbox"/>
E-061	Vacuum Backpack	ProTeam	Super CoachVac	<input type="checkbox"/>	4	<input type="checkbox"/>	<input type="checkbox"/>	<input type="checkbox"/>
E-062	Carpet Cleaner	Tenant	R-3 Compact, R	<input type="checkbox"/>	1	<input type="checkbox"/>	<input type="checkbox"/>	<input type="checkbox"/>
E-063	Boom Lift- Electric	JLG	E300AJD	<input type="checkbox"/>	1	<input type="checkbox"/>	<input type="checkbox"/>	<input type="checkbox"/>
E-064	Wet/Dry Vacuum	Tennant	3500/607673	<input type="checkbox"/>	1	<input type="checkbox"/>	<input type="checkbox"/>	<input type="checkbox"/>
E-065	Floor Scrubber	Tenant	T-7 Micro-rider	<input type="checkbox"/>	1	<input type="checkbox"/>	<input type="checkbox"/>	<input type="checkbox"/>
E-066	Floor Machine	Milestone Equipment-General Floorcraft Floor Maintenance	KC-20 Series	<input type="checkbox"/>	1	<input type="checkbox"/>	<input type="checkbox"/>	<input type="checkbox"/>
E-067	Floor Burnisher	Grainger-Nobles	4VDX2	<input type="checkbox"/>	1	<input type="checkbox"/>	<input type="checkbox"/>	<input type="checkbox"/>
E-068	Snow Blower	Honda	HS928WAS	<input type="checkbox"/>	1	<input type="checkbox"/>	<input type="checkbox"/>	<input type="checkbox"/>
E-069	Cleaning System	KaiVac	1250	<input type="checkbox"/>	1	<input type="checkbox"/>	<input type="checkbox"/>	<input type="checkbox"/>
E-070	Electric Pressure Washer	Grainger	3WB88	<input type="checkbox"/>	1	<input type="checkbox"/>	<input type="checkbox"/>	<input type="checkbox"/>
E-071	Heat Buster Fan	Industrial Fans Direct	TPC4213	<input type="checkbox"/>	1	<input type="checkbox"/>	<input type="checkbox"/>	<input type="checkbox"/>
E-072	Carpet Dryer	Minuteman	C42000-01	<input type="checkbox"/>	1	<input type="checkbox"/>	<input type="checkbox"/>	<input type="checkbox"/>
E-073	Six Foot Fiber Glass Step Ladder	American Ladder	7406	<input type="checkbox"/>	1	<input type="checkbox"/>	<input type="checkbox"/>	<input type="checkbox"/>
E-074	Eight Foot Fiber Glass Step Ladder	American Ladder	7408	<input type="checkbox"/>	1	<input type="checkbox"/>	<input type="checkbox"/>	<input type="checkbox"/>
E-075	Standard Hand Truck	U-Line	H-1361 10" SOLI	<input type="checkbox"/>	1	<input type="checkbox"/>	<input type="checkbox"/>	<input type="checkbox"/>
E-076	Heavy Duty Platform Truck	Global Industries	T9C241579	<input type="checkbox"/>	1	<input type="checkbox"/>	<input type="checkbox"/>	<input type="checkbox"/>
E-078	Refridgerator	U-Line	Combo Refridge	<input type="checkbox"/>	1	<input type="checkbox"/>	<input type="checkbox"/>	<input type="checkbox"/>
E-079	Microwave	GE	JEB1860DMBB	<input type="checkbox"/>	1	<input type="checkbox"/>	<input type="checkbox"/>	<input type="checkbox"/>

CODE	ITEM	MANUFACTURER	STYLE / MODEL	SUBSTITUTION	QTY.	UNIT PRICE (\$)	TOTAL (\$)	Substitution check if yes
E-081	Chair Dolly	KI	MATRIX Chair D	<input type="checkbox"/>	14	<input type="checkbox"/>	<input type="checkbox"/>	<input type="checkbox"/>
E-082	Large Narcotic Cabinet	School Health	42021	<input type="checkbox"/>	1	<input type="checkbox"/>	<input type="checkbox"/>	<input type="checkbox"/>
E-083	First Aid Wall Cabinet	School Health	42026	<input type="checkbox"/>	1	<input type="checkbox"/>	<input type="checkbox"/>	<input type="checkbox"/>
E-084	Emergency Kit	Jackson	Emergency Kit	<input type="checkbox"/>	1	<input type="checkbox"/>	<input type="checkbox"/>	<input type="checkbox"/>
E-085	Maico Audiometer	Maico	Ultra Portable A	<input type="checkbox"/>	1	<input type="checkbox"/>	<input type="checkbox"/>	<input type="checkbox"/>
E-086	Titmus V4 General Testing Model	Titmus	V4 Pediatric Tes	<input type="checkbox"/>	1	<input type="checkbox"/>	<input type="checkbox"/>	<input type="checkbox"/>
E-087	School Health Wheel Chair	School Health	Wheelchair 24"	<input type="checkbox"/>	1	<input type="checkbox"/>	<input type="checkbox"/>	<input type="checkbox"/>
E-088	Zoll AED Plus Defibulator	Zoll	AED Plus Unit a	<input type="checkbox"/>	2	<input type="checkbox"/>	<input type="checkbox"/>	<input type="checkbox"/>
E-089	Welch Allyn Spot Vital Signs	Welch Allyn	Spot Vital Signs	<input type="checkbox"/>	1	<input type="checkbox"/>	<input type="checkbox"/>	<input type="checkbox"/>
E-090	Stand Alone Mobile Cabinet w/ Lock	School Health	24598	<input type="checkbox"/>	1	<input type="checkbox"/>	<input type="checkbox"/>	<input type="checkbox"/>
E-091	Stand alone wall mounted Digital Height Rod	School Health	58096	<input type="checkbox"/>	1	<input type="checkbox"/>	<input type="checkbox"/>	<input type="checkbox"/>
E-092	Faucet Mounted Eye Wash System	EyeSafe	AC42155	<input type="checkbox"/>	1	<input type="checkbox"/>	<input type="checkbox"/>	<input type="checkbox"/>
E-093	Shredder	School Specialty-Swingline	ShredDaster GL	<input type="checkbox"/>	1	<input type="checkbox"/>	<input type="checkbox"/>	<input type="checkbox"/>
E-094	Walkie Talkies	Colony Hardware Supply Co. Inc	2 Watt- 2-Chan	<input type="checkbox"/>	12	<input type="checkbox"/>	<input type="checkbox"/>	<input type="checkbox"/>
E-095	Chair Dollies- Immersive	Avarte	Funktus	<input type="checkbox"/>	10	<input type="checkbox"/>	<input type="checkbox"/>	<input type="checkbox"/>
E-096	Stereo Microscopes	Dissecting Microscopes.com	du028aed0m	<input type="checkbox"/>	1	<input type="checkbox"/>	<input type="checkbox"/>	<input type="checkbox"/>
E-097	Human Life Skeleton	Carolina	46875	<input type="checkbox"/>	1	<input type="checkbox"/>	<input type="checkbox"/>	<input type="checkbox"/>
E-098	Human Eye Model	Carolina	566944	<input type="checkbox"/>	1	<input type="checkbox"/>	<input type="checkbox"/>	<input type="checkbox"/>
E-099	Human Ear Model	Carolina	566965	<input type="checkbox"/>	1	<input type="checkbox"/>	<input type="checkbox"/>	<input type="checkbox"/>

CODE	ITEM	MANUFACTURER	STYLE / MODEL	SUBSTITUTION	QTY.	UNIT PRICE (\$)	TOTAL (\$)	Substitution check if yes
E-100	Human Heart Model	The Therapy Connection at HPMS Inc.	ANA-G10	<input type="checkbox"/>	1	<input type="checkbox"/>	<input type="checkbox"/>	<input type="checkbox"/>
E-101	Animal Skeleton Snake	MilesCo Scientific	805F	<input type="checkbox"/>	1	<input type="checkbox"/>	<input type="checkbox"/>	<input type="checkbox"/>
E-102	Long Handed Nets 1	Foster and Smith Aquatics	CE-19192	<input type="checkbox"/>	1	<input type="checkbox"/>	<input type="checkbox"/>	<input type="checkbox"/>
E-103	Short Handed Strainers	Foster and Smith Aquatics	CE-19193	<input type="checkbox"/>	1	<input type="checkbox"/>	<input type="checkbox"/>	<input type="checkbox"/>
E-104	Long Handed Nets 2	Nature Pavillion-Adventure Products	B001PF51PI	<input type="checkbox"/>	1	<input type="checkbox"/>	<input type="checkbox"/>	<input type="checkbox"/>
E-105	Trowels	No Thyme Productins-Children's Quality Garden	Z55564	<input type="checkbox"/>	1	<input type="checkbox"/>	<input type="checkbox"/>	<input type="checkbox"/>
E-106	Pig Lung Demo Kit	Ward's Natural Science	81 V 2003	<input type="checkbox"/>	1	<input type="checkbox"/>	<input type="checkbox"/>	<input type="checkbox"/>
E-107	Digital Thermometers	Science Kit	WW01765M35	<input type="checkbox"/>	1	<input type="checkbox"/>	<input type="checkbox"/>	<input type="checkbox"/>
E-108	Animal & Plant Life Cycle Cards	Teaching Supply Store	LER2928	<input type="checkbox"/>	1	<input type="checkbox"/>	<input type="checkbox"/>	<input type="checkbox"/>
E-109	Solar System Model	American Educational Products	B0017Y7MB8	<input type="checkbox"/>	1	<input type="checkbox"/>	<input type="checkbox"/>	<input type="checkbox"/>
E-110	Weather Station	Davis Vantage Pro 2	DO-86403-03	<input type="checkbox"/>	1	<input type="checkbox"/>	<input type="checkbox"/>	<input type="checkbox"/>
E-111	Weather Reporting Camera	Pentax	E167559	<input type="checkbox"/>	1	<input type="checkbox"/>	<input type="checkbox"/>	<input type="checkbox"/>
E-112	Weather Reporting Board	Shop.com	AMED409	<input type="checkbox"/>	1	<input type="checkbox"/>	<input type="checkbox"/>	<input type="checkbox"/>
E-113	Camera	Canon	PowerShot ELP	<input type="checkbox"/>	1	<input type="checkbox"/>	<input type="checkbox"/>	<input type="checkbox"/>
E-114	Work Bench	Wood Craft	146469	<input type="checkbox"/>	2	<input type="checkbox"/>	<input type="checkbox"/>	<input type="checkbox"/>
E-115	Tool Storage	Sears	30-WRK-400RB	<input type="checkbox"/>	1	<input type="checkbox"/>	<input type="checkbox"/>	<input type="checkbox"/>
E-116	Storage Bins	NA	NA	<input type="checkbox"/>	1	<input type="checkbox"/>	<input type="checkbox"/>	<input type="checkbox"/>
E-117	Floor Lamp	Meijer- Adesso	65010122	<input type="checkbox"/>	1	<input type="checkbox"/>	<input type="checkbox"/>	<input type="checkbox"/>

CODE	ITEM	MANUFACTURER	STYLE / MODEL	SUBSTITUTION	QTY.	UNIT PRICE (\$)	TOTAL (\$)	Substitution check if yes
E-118	Water & Sand Table	Daycare Furniture Shop.com- Jonti-Craft	JC048	<input type="checkbox"/>	2	<input type="checkbox"/>	<input type="checkbox"/>	<input type="checkbox"/>
E-119	Rolling Cart	ScripHesso	2720012	<input type="checkbox"/>	1	<input type="checkbox"/>	<input type="checkbox"/>	<input type="checkbox"/>
E-120	Weather Station Software	Data Logger Software	6510USB	<input type="checkbox"/>	1	<input type="checkbox"/>	<input type="checkbox"/>	<input type="checkbox"/>
E-121	Weather Station Mounting Tripod	Davis	07716	<input type="checkbox"/>	1	<input type="checkbox"/>	<input type="checkbox"/>	<input type="checkbox"/>
E-122	Work Table	Amazon	B001TMEX7E	<input type="checkbox"/>	1	<input type="checkbox"/>	<input type="checkbox"/>	<input type="checkbox"/>
E-123	Poster Cabinet	Tiger Supplies	3042-5DB-SDG:	<input type="checkbox"/>	1	<input type="checkbox"/>	<input type="checkbox"/>	<input type="checkbox"/>
E-124	Grow Lab	Gardening With Kids	10-1214E	<input type="checkbox"/>	1	<input type="checkbox"/>	<input type="checkbox"/>	<input type="checkbox"/>
E-125	Planting Center	AllGreenHouses.Com	JU1117	<input type="checkbox"/>	1	<input type="checkbox"/>	<input type="checkbox"/>	<input type="checkbox"/>
E-127	Rug 1	Worthington Direct	34176	<input type="checkbox"/>	1	<input type="checkbox"/>	<input type="checkbox"/>	<input type="checkbox"/>
E-128	Rug 2	Worthington Direct- Joy Carpets	50107	<input type="checkbox"/>	1	<input type="checkbox"/>	<input type="checkbox"/>	<input type="checkbox"/>
E-129	Demo Storage Cart	Hertz Furniture-Diversified Woodcrafts	DVR-4402	<input type="checkbox"/>	1	<input type="checkbox"/>	<input type="checkbox"/>	<input type="checkbox"/>
E-130	Demo Lab Table	Hertz Furniture-Diversified Woodcrafts	DVR-4502	<input type="checkbox"/>	2	<input type="checkbox"/>	<input type="checkbox"/>	<input type="checkbox"/>
E-133	Pallet Jack	Grainger	BTL2300U	<input type="checkbox"/>	1	<input type="checkbox"/>	<input type="checkbox"/>	<input type="checkbox"/>
E-135	Rolling Wire Shelves	Global Industrial	188208	<input type="checkbox"/>	3	<input type="checkbox"/>	<input type="checkbox"/>	<input type="checkbox"/>
E-136	Wire Shelving	Global Industries	188240	<input type="checkbox"/>	1	<input type="checkbox"/>	<input type="checkbox"/>	<input type="checkbox"/>
E-137	Wire Shelving Covers	Alera	W59SL4824	<input type="checkbox"/>	4	<input type="checkbox"/>	<input type="checkbox"/>	<input type="checkbox"/>
E-138	Wire Shelving Casters	Global Industries	CS18491299.95	<input type="checkbox"/>	16	<input type="checkbox"/>	<input type="checkbox"/>	<input type="checkbox"/>
E-139	Recycle Bins	Global Industries-Akro-Mils	662122	<input type="checkbox"/>	3	<input type="checkbox"/>	<input type="checkbox"/>	<input type="checkbox"/>

CODE	ITEM	MANUFACTURER	STYLE / MODEL	SUBSTITUTION	QTY.	UNIT PRICE (\$)	TOTAL (\$)	Substitution check if yes
E-140	Laptop/ Document Camera Cart	Balt	BAL-27519	<input type="checkbox"/>	29	<input type="checkbox"/>	<input type="checkbox"/>	<input type="checkbox"/>
E-141	Lecturn	AmpliVox	SN3130	<input type="checkbox"/>	2	<input type="checkbox"/>	<input type="checkbox"/>	<input type="checkbox"/>
E-142	Refridgerator	GE	GTH18HCCWW-	<input type="checkbox"/>	2	<input type="checkbox"/>	<input type="checkbox"/>	<input type="checkbox"/>
E-143	Terrarium Set Up	Exotic Fish and Corals	Varies	<input type="checkbox"/>	1	<input type="checkbox"/>	<input type="checkbox"/>	<input type="checkbox"/>
E-144	Camcarts	Cambro	1826LTC	<input type="checkbox"/>	3	<input type="checkbox"/>	<input type="checkbox"/>	<input type="checkbox"/>
F-002	File Shuttle & Companion File	School Specialty	1329876 & 090	<input type="checkbox"/>	1	<input type="checkbox"/>	<input type="checkbox"/>	<input type="checkbox"/>
F-003	Wood Lateral	First Office	17-3858LF4 Sm	<input type="checkbox"/>	4	<input type="checkbox"/>	<input type="checkbox"/>	<input type="checkbox"/>
S-001	Metal Shelving	Uline	651442	<input type="checkbox"/>	92	<input type="checkbox"/>	<input type="checkbox"/>	<input type="checkbox"/>
S-002	Classroom Bookcase	Vanerum Stelter	SH.AR.SL.DS.36	<input type="checkbox"/>	44	<input type="checkbox"/>	<input type="checkbox"/>	<input type="checkbox"/>
S-003	Big Book Display	Brodart	VL 015 001	<input type="checkbox"/>	9	<input type="checkbox"/>	<input type="checkbox"/>	<input type="checkbox"/>
S-004	Mobile Cubby Unit	Vanerum Stelter	SP.ST.18472-01	<input type="checkbox"/>	63	<input type="checkbox"/>	<input type="checkbox"/>	<input type="checkbox"/>
S-005	Cubby w/ Clear Trays	School Specialty- Korners for Kids	1335325- cubby	<input type="checkbox"/>	1	<input type="checkbox"/>	<input type="checkbox"/>	<input type="checkbox"/>
S-006	Storage Unit	Vanerum Stelter	ST.FO.SC.4S.301	<input type="checkbox"/>	1	<input type="checkbox"/>	<input type="checkbox"/>	<input type="checkbox"/>
S-007	Rolling Utility Cart	School Specialty	678771	<input type="checkbox"/>	4	<input type="checkbox"/>	<input type="checkbox"/>	<input type="checkbox"/>
S-008	Gym/PE Storage	Uline	H-1528	<input type="checkbox"/>	10	<input type="checkbox"/>	<input type="checkbox"/>	<input type="checkbox"/>
S-009	Storage Cabinet	Vegas	3-7236SW2	<input type="checkbox"/>	11	<input type="checkbox"/>	<input type="checkbox"/>	<input type="checkbox"/>
S-010	Flat File Cabinet	Paramount	T9A506826GY	<input type="checkbox"/>	2	<input type="checkbox"/>	<input type="checkbox"/>	<input type="checkbox"/>
S-011	2 Drawer	First Office	Vegas- 36" Late	<input type="checkbox"/>	1	<input type="checkbox"/>	<input type="checkbox"/>	<input type="checkbox"/>
S-013	Safe	School Specialty- Sentry Safe	1121619	<input type="checkbox"/>	1	<input type="checkbox"/>	<input type="checkbox"/>	<input type="checkbox"/>
S-014	Garment Racks	Wenger	Rack N Roll Gar	<input type="checkbox"/>	4	<input type="checkbox"/>	<input type="checkbox"/>	<input type="checkbox"/>
S-015	Classroom Bookcase	Vanerum Stelter	SH.AR.SL.S.3612	<input type="checkbox"/>	92	<input type="checkbox"/>	<input type="checkbox"/>	<input type="checkbox"/>
S-016	Wooden Shelving	First Office	Vegas	<input type="checkbox"/>	4	<input type="checkbox"/>	<input type="checkbox"/>	<input type="checkbox"/>
S-018	Classroom Bookcase	Vanerum Stelter		<input type="checkbox"/>	42	<input type="checkbox"/>	<input type="checkbox"/>	<input type="checkbox"/>

CODE	ITEM	MANUFACTURER	STYLE / MODEL	SUBSTITUTION	QTY.	UNIT PRICE (\$)	TOTAL (\$)	Substitution check if yes
T-001	Round Table	Smith System	04330	<input type="checkbox"/>	47	<input type="checkbox"/>	<input type="checkbox"/>	<input type="checkbox"/>
T-002	Trapezoid Table	Jonti-Craft Inc- Rainbow Accents	6438JCA210	<input type="checkbox"/>	34	<input type="checkbox"/>	<input type="checkbox"/>	<input type="checkbox"/>
T-003	Kidney Table	Virco	48C00P72	<input type="checkbox"/>	18	<input type="checkbox"/>	<input type="checkbox"/>	<input type="checkbox"/>
T-004	Small Table	Jonti Craft	Activity Table	<input type="checkbox"/>	22	<input type="checkbox"/>	<input type="checkbox"/>	<input type="checkbox"/>
T-005	Adjustable Height Table	Hertz Furniture- Diversified Woodcrafts	DVR-8102	<input type="checkbox"/>	12	<input type="checkbox"/>	<input type="checkbox"/>	<input type="checkbox"/>
T-006	Computer Tables	Smith Systems	Flex Station Tab	<input type="checkbox"/>	52	<input type="checkbox"/>	<input type="checkbox"/>	<input type="checkbox"/>
T-007	ADA Compliant Tables	Smith Systems	Flex Station	<input type="checkbox"/>	29	<input type="checkbox"/>	<input type="checkbox"/>	<input type="checkbox"/>
T-008	Technology Tables	Vanerum Stelter	TB.TRG.ST.3624	<input type="checkbox"/>	25	<input type="checkbox"/>	<input type="checkbox"/>	<input type="checkbox"/>
T-009	Round Conference Table	First Office	Vegas 48" Roun	<input type="checkbox"/>	1	<input type="checkbox"/>	<input type="checkbox"/>	<input type="checkbox"/>
T-010	Round Student Tables	Smith Systems	04335 60" Roun	<input type="checkbox"/>	20	<input type="checkbox"/>	<input type="checkbox"/>	<input type="checkbox"/>
T-011	Rectangular Tables	TMC Furniture	TR3060L10	<input type="checkbox"/>	7	<input type="checkbox"/>	<input type="checkbox"/>	<input type="checkbox"/>
T-012	Round Café Table w/ Stools	Midwest	Mobile Stool Un	<input type="checkbox"/>	22	<input type="checkbox"/>	<input type="checkbox"/>	<input type="checkbox"/>
T-013	Round Café Table- ADA Compliant	Midwest	Mobile Stool Un	<input type="checkbox"/>	6	<input type="checkbox"/>	<input type="checkbox"/>	<input type="checkbox"/>
T-014	Art Tables	School Specialty- Allied Plastics	561794	<input type="checkbox"/>	6	<input type="checkbox"/>	<input type="checkbox"/>	<input type="checkbox"/>
T-016	Boat Shaped Conference Table	First Office	Vegas 96" Boat	<input type="checkbox"/>	2	<input type="checkbox"/>	<input type="checkbox"/>	<input type="checkbox"/>
T-017	Library Tables	TMC Furniture	Kestrel Table- S	<input type="checkbox"/>	6	<input type="checkbox"/>	<input type="checkbox"/>	<input type="checkbox"/>

**TOTAL BID AMOUNT:**

Lump Sum Bid Price of: \_\_\_\_\_

\_\_\_\_\_ Dollars \$ \_\_\_\_\_

(Show amount in both words and figures. In case of a discrepancy, amount shown in words will govern.)

**ADDENDUM ACCEPTANCE FORM**

The lump sum bid indicated on the Quotation/Bid Proposal Form includes all stipulations and requirements of the following Addenda which have been received and accepted. Please fill-in Addendum Number and Date below and include this form with sealed bids.

Addendum Number \_\_\_\_\_ dated \_\_\_\_\_

Addendum Number \_\_\_\_\_ dated \_\_\_\_\_

Addendum Number \_\_\_\_\_ dated \_\_\_\_\_

Addendum Number \_\_\_\_\_ dated \_\_\_\_\_

Addendum Number \_\_\_\_\_ dated \_\_\_\_\_

Name \_\_\_\_\_

Signature \_\_\_\_\_

END OF SECTION

THIS PAGE INTENTIONALLY LEFT BLANK



# SUBSTITUTION REQUEST FORM

This Substitution Request Form must be included for Bid Substitution Requests refer to Supplementary Instructions to Bidders for substitution procedures.

**TO:** Fletcher Thompson Inc  
Attn: Kate Ryan  
Three Corporate Drive  
Shelton, CT 06484-6244

**PROJECT:** Moveable Equipment  
Glastonbury East Hartford Elementary  
Magnet School  
95 Oak Street  
Glastonbury, Connecticut  
State Project No. 054-0095 MAG/N/PS  
Phase 3 of 4  
GL-2011-04/BP-118

A/E PROJECT NO: H090230 DATE: \_\_\_\_\_

## SPECIFICATION ITEM:

Code	Manufacturer	Style
------	--------------	-------

Substitution approval is an acceptance of only the manufacturer and product for general conformance with the design concept reflected in the Contract Documents. All substitutions must be reviewed and approved by owner for final acceptance. The A/E has made no attempt to verify specific performance data, or to check the details of the proposed substitution as to special features, capacities, physical dimensions or code and/or regulatory compliance, all of which remain the responsibility of the person/entity submitting the proposed substitution.

The undersigned requests consideration of the following:

## PROPOSED SUBSTITUTION:

Code	Manufacturer	Style	Unit Cost
------	--------------	-------	-----------

Attached data includes product description, specifications, drawings, photographs, finishes, performance and test data, adequate for evaluation of the request; applicable portions of the data are clearly identified.  
Attached data also includes a description of changes to the Contract Documents that the proposed substitution will require for its proper installation.

The undersigned certifies that the following paragraphs, unless modified by attachments, are correct:

1. The proposed substitution does not affect dimensions shown on the Drawings.
2. Maintenance and service parts will be **locally** available for the proposed substitution.

The undersigned further certifies that the function, appearance, and quality of the proposed substitution are *equivalent or superior* to the specified item.

The undersigned agrees that, if this page is reproduced, the terms and conditions for substitutions found in the Bidding and Contract Documents apply to this request.

## SUBMITTED BY:

\_\_\_\_\_  
Name ( Printed )

\_\_\_\_\_  
Contractor ( if after award of Contract )

\_\_\_\_\_  
Signature

For use by the A/E  
 Accepted  Accepted as noted  
 Not Accepted  Received too late  
 Incomplete Information

\_\_\_\_\_  
Firm Name

\_\_\_\_\_  
Address

\_\_\_\_\_  
City, State, Zip

\_\_\_\_\_  
Reviewed By

\_\_\_\_\_  
Date

\_\_\_\_\_  
Date

\_\_\_\_\_  
Telephone Fax

\_\_\_\_\_  
Remark

THIS PAGE INTENTIONALLY LEFT BLANK



# AIA<sup>®</sup> Document A310<sup>™</sup> – 1970

## ***Bid Bond***

KNOW ALL MEN BY THESE PRESENTS, that we  
*(Here insert full name and address or legal title of Contractor)*

as Principal, hereinafter called the Principal, and  
*(Here insert full name and address or legal title of Surety)*

a corporation duly organized under the laws of the State of as Surety, hereinafter called  
the Surety, are held and firmly bound unto  
*(Here insert full name and address or legal title of Owner)*

as Obligee, hereinafter called the Obligee, in the sum of (\$ ), for the payment of  
which sum well and truly to be made, the said Principal and the said Surety, bind  
ourselves, our heirs, executors, administrators, successors and assigns, jointly and  
severally, firmly by these presents.

WHEREAS, the Principal has submitted a bid for  
*(Here insert full name, address and description of project)*

NOW, THEREFORE, if the Obligee shall accept the bid of the Principal and the  
Principal shall enter into a Contract with the Obligee in accordance with the terms of  
such bid, and give such bond or bonds as may be specified in the bidding or Contract  
Documents with good and sufficient surety for the faithful performance of such Contract  
and for the prompt payment of labor and material furnished in the prosecution thereof, or  
in the event of the failure of the Principal to enter such Contract and give such bond or  
bonds, if the Principal shall pay to the Obligee the difference not to exceed the penalty  
hereof between the amount specified in said bid and such larger amount for which the  
Obligee may in good faith contract with another party to perform the Work covered by  
said bid, then this obligation shall be null and void, otherwise to remain in full force and  
effect.

### **ADDITIONS AND DELETIONS:**

The author of this document has added information needed for its completion. The author may also have revised the text of the original AIA standard form. An *Additions and Deletions Report* that notes added information as well as revisions to the standard form text is available from the author and should be reviewed. A vertical line in the left margin of this document indicates where the author has added necessary information and where the author has added to or deleted from the original AIA text.

This document has important legal consequences. Consultation with an attorney is encouraged with respect to its completion or modification.

Signed and sealed this \_\_\_\_\_ day of \_\_\_\_\_ ,

\_\_\_\_\_  
(Witness)

\_\_\_\_\_  
(Witness)

\_\_\_\_\_  
(Principal) (Seal)

\_\_\_\_\_  
(Title)

\_\_\_\_\_  
(Surety)

\_\_\_\_\_  
(Title) (Seal)

## **Additions and Deletions Report for AIA<sup>®</sup> Document A310<sup>™</sup> – 1970**

This Additions and Deletions Report, as defined on page 1 of the associated document, reproduces below all text the author has added to the standard form AIA document in order to complete it, as well as any text the author may have added to or deleted from the original AIA text. Added text is shown underlined. Deleted text is indicated with a horizontal line through the original AIA text.

Note: This Additions and Deletions Report is provided for information purposes only and is not incorporated into or constitute any part of the associated AIA document. This Additions and Deletions Report and its associated document were generated simultaneously by AIA software at 10:45:18 on 12/17/2007.

*There are no differences.*

## **Certification of Document's Authenticity**

**AIA® Document D401™ – 2003**

I, Robert McNamara, hereby certify, to the best of my knowledge, information and belief, that I created the attached final document simultaneously with its associated Additions and Deletions Report and this certification at 10:45:18 on 12/17/2007 under Order No. 1000291968\_3 from AIA Contract Documents software and that in preparing the attached final document I made no changes to the original text of AIA® Document A310™ – 1970 - Bid Bond, as published by the AIA in its software, other than those additions and deletions shown in the associated Additions and Deletions Report.

---

*(Signed)*

---

*(Title)*

---

*(Dated)*





# AIA<sup>®</sup> Document A305<sup>™</sup> – 1986

## Contractor's Qualification Statement

The Undersigned certifies under oath that the information provided herein is true and sufficiently complete so as not to be misleading.

SUBMITTED TO:

ADDRESS:

SUBMITTED BY:

NAME:

ADDRESS:

PRINCIPAL OFFICE:

- Corporation
- Partnership
- Individual
- Joint Venture
- Other

NAME OF PROJECT (if applicable): Blank

TYPE OF WORK (file separate form for each Classification of Work):

- General Construction
- HVAC
- Electrical
- Plumbing
- Other (please specify)

### § 1. ORGANIZATION

§ 1.1 How many years has your organization been in business as a Contractor?

§ 1.2 How many years has your organization been in business under its present business name?

§ 1.2.1 Under what other or former names has your organization operated?

§ 1.3 If your organization is a corporation, answer the following:

- § 1.3.1 Date of incorporation:
- § 1.3.2 State of incorporation:
- § 1.3.3 President's name:

### ADDITIONS AND DELETIONS:

The author of this document has added information needed for its completion. The author may also have revised the text of the original AIA standard form. An *Additions and Deletions Report* that notes added information as well as revisions to the standard form text is available from the author and should be reviewed. A vertical line in the left margin of this document indicates where the author has added necessary information and where the author has added to or deleted from the original AIA text.

This document has important legal consequences. Consultation with an attorney is encouraged with respect to its completion or modification.

This form is approved and recommended by the American Institute of Architects (AIA) and The Associated General Contractors of America (AGC) for use in evaluating the qualifications of contractors. No endorsement of the submitting party or verification of the information is made by AIA or AGC.

§ 1.3.4 Vice-president's name(s)

§ 1.3.5 Secretary's name:

§ 1.3.6 Treasurer's name:

§ 1.4 If your organization is a partnership, answer the following:

§ 1.4.1 Date of organization:

§ 1.4.2 Type of partnership (if applicable):

§ 1.4.3 Name(s) of general partner(s)

§ 1.5 If your organization is individually owned, answer the following:

§ 1.5.1 Date of organization:

§ 1.5.2 Name of owner:

§ 1.6 If the form of your organization is other than those listed above, describe it and name the principals:

## § 2. LICENSING

§ 2.1 List jurisdictions and trade categories in which your organization is legally qualified to do business, and indicate registration or license numbers, if applicable.

§ 2.2 List jurisdictions in which your organization's partnership or trade name is filed.

## § 3. EXPERIENCE

§ 3.1 List the categories of work that your organization normally performs with its own forces.

§ 3.2 Claims and Suits. (If the answer to any of the questions below is yes, please attach details.)

§ 3.2.1 Has your organization ever failed to complete any work awarded to it?

§ 3.2.2 Are there any judgments, claims, arbitration proceedings or suits pending or outstanding against your organization or its officers?

§ 3.2.3 Has your organization filed any law suits or requested arbitration with regard to construction contracts within the last five years?

§ 3.3 Within the last five years, has any officer or principal of your organization ever been an officer or principal of another organization when it failed to complete a construction contract? (If the answer is yes, please attach details.)



§ 3.4 On a separate sheet, list major construction projects your organization has in progress, giving the name of project, owner, architect, contract amount, percent complete and scheduled completion date.

§ 3.4.1 State total worth of work in progress and under contract:

§ 3.5 On a separate sheet, list the major projects your organization has completed in the past five years, giving the name of project, owner, architect, contract amount, date of completion and percentage of the cost of the work performed with your own forces.

§ 3.5.1 State average annual amount of construction work performed during the past five years:

§ 3.6 On a separate sheet, list the construction experience and present commitments of the key individuals of your organization.

#### § 4. REFERENCES

§ 4.1 Trade References:

§ 4.2 Bank References:

§ 4.3 Surety:

§ 4.3.1 Name of bonding company:

§ 4.3.2 Name and address of agent:

#### § 5. FINANCING

§ 5.1 Financial Statement.

§ 5.1.1 Attach a financial statement, preferably audited, including your organization's latest balance sheet and income statement showing the following items:

Current Assets (e.g., cash, joint venture accounts, accounts receivable, notes receivable, accrued income, deposits, materials inventory and prepaid expenses);

Net Fixed Assets;

Other Assets;

Current Liabilities (e.g., accounts payable, notes payable, accrued expenses, provision for income taxes, advances, accrued salaries and accrued payroll taxes);

Other Liabilities (e.g., capital, capital stock, authorized and outstanding shares par values, earned surplus and retained earnings).

§ 5.1.2 Name and address of firm preparing attached financial statement, and date thereof:

§ 5.1.3 Is the attached financial statement for the identical organization named on page one?

§ 5.1.4 If not, explain the relationship and financial responsibility of the organization whose financial statement is provided (e.g., parent-subsidiary).

§ 5.2 Will the organization whose financial statement is attached act as guarantor of the contract for construction?

**§ 6. SIGNATURE**

§ 6.1 Dated at this    day of

Name of Organization:

By:

Title:

§ 6.2

M    being duly sworn deposes and says that the information provided herein is true and sufficiently complete so as not to be misleading.

Subscribed and sworn before me this    day of

Notary Public:

My Commission Expires:

## ***Additions and Deletions Report for AIA<sup>®</sup> Document A305<sup>™</sup> – 1986***

This Additions and Deletions Report, as defined on page 1 of the associated document, reproduces below all text the author has added to the standard form AIA document in order to complete it, as well as any text the author may have added to or deleted from the original AIA text. Added text is shown underlined. Deleted text is indicated with a horizontal line through the original AIA text.

Note: This Additions and Deletions Report is provided for information purposes only and is not incorporated into or constitute any part of the associated AIA document. This Additions and Deletions Report and its associated document were generated simultaneously by AIA software at 11:03:11 on 02/09/2010.

**PAGE 1**

**NAME OF PROJECT** *(if applicable):* Blank

## ***Certification of Document's Authenticity***

***AIA® Document D401™ – 2003***

I, \_\_\_\_\_, hereby certify, to the best of my knowledge, information and belief, that I created the attached final document simultaneously with its associated Additions and Deletions Report and this certification at 11:03:11 on 02/09/2010 under Order No. 1000390578\_2 from AIA Contract Documents software and that in preparing the attached final document I made no changes to the original text of AIA® Document A305™ – 1986 - Contractor's Qualification Statement, as published by the AIA in its software, other than those additions and deletions shown in the associated Additions and Deletions Report.

\_\_\_\_\_  
*(Signed)*

\_\_\_\_\_  
*(Title)*

\_\_\_\_\_  
*(Dated)*

## PART 1 - GENERAL

## 1.1 CONTRACTOR QUALIFICATIONS

- A. All Bidders are required to include with their bid a completed Contractor Qualification Questionnaire under this section.
1. Any questions regarding this Contractor Qualification Questionnaire may be directed to the Construction Manager; Attention: Julia Tibbo, Project Manager, Job Site Phone: 860-676-2200.
- B. Each Bidder shall demonstrate, to the satisfaction of the Owner, that it is able to post 100% Labor and Material Payment and Performance Bonds satisfactory for the project and required by the Contract and that it possesses the financial, managerial and technical ability, and the integrity necessary to faithfully and efficiently perform the work for which it intends to bid. The Owner reserves the right to require the three apparent low bidders for each bid package to promptly submit a completed Contractors Qualification Statement (AIA Document A-305) demonstrating to the Owner's satisfaction that they are qualified. The Owner also reserves the right to find any Bidder to be non-responsible, non-responsive, conditional or unqualified, notwithstanding the fact that the Bidder may have been previously found to have been qualified. The Owner may make such investigations as it deems necessary to determine the ability, qualifications, integrity and experience of the bidder to perform the work. The bidder shall promptly furnish the Owner all such information for this purpose as the Owner may request.
- C. Bidder shall itemize in writing with its bid its ability to meet rapid and critical schedules on major projects of a size and complexity similar to this project. List at least three examples of such work performed by the Bidder during the past ten (10) years. Bidders shall, in this attachment, detail its ability to obtain material, workers, equipment, supervision and capital to meet such schedules in the past and for this project specifically.
- D. If requested, the Bidder shall be able to furnish references from Contractors, Owners, Architects or Engineers indicating that it has satisfactorily and timely completed work similar to the project being bid.
- E. The Bidder shall have a record of harmonious relationships with municipalities, Construction Managers, Contractors and subcontractors on prior public projects or other projects where the Bidder may have performed.
- F. The Bidder shall demonstrate that it has not been cited for three or more willful or serious violations of any OSHA or of any similar State standard, order or regulations promulgated pursuant to such act, during the 3-year period preceding any bid which is being submitted, which were not abated within the time fixed by citation; unless the citations have been set aside following appeal to the appropriate agency or court having jurisdiction.

- G. The Bidder, or any entity in which it has an interest, shall not have appeared on any list published by the Connecticut State Labor Commission of persons or firms whom it has found to have disregarded their obligations under Connecticut General Statutes Sections 31-53 and 31-76c to employees and subcontractors on public works projects or to have been barred from federal government contracts in accordance with the provisions of the Davis Bacon Act, 40 U.S.C. 276a-2, if said list has been published less than three years prior to the Award of any Contract to the Bidder.
- H. The Bidder or its principals, regardless of their place of employment, shall not have been convicted of, nor entered any plea of guilty, or nolo contendere, or otherwise have been found civilly liable or criminally responsible for any criminal offense or civil action involving embezzlement; forgery; bribery; falsification or destruction of records; receipt of stolen property; collusion, antitrust, conspiracy, violation of State Ethics standards or other offenses arising out of the submission of bids or proposals, or performance of work, on public works projects or contracts.
- I. Bidder must describe its ownership, management and corporate (if applicable) structure and status over the past 3 years, noting whether it or any of its principals have filed any Bankruptcy Petitions within that time.
- J. Bidder shall include on a sheet(s) attached to its proposal a complete disclosure of all past and pending mediation, arbitration and litigation cases that the Bidder or its principals (regardless of their place of employment) have been involved in for the most recent five years. Please include a statement of the issues in dispute and their resolution. Acceptability of Bidder based on this disclosure shall lie solely with the Owner, Architect and Construction Manager.
- K. Bidder are encouraged to attend the Non-Mandatory Pre-Bid Conference. See "Legal Notice / Invitation to Bidders."
- L. Bidder SHALL NOT have been debarred, or otherwise denied permission, within the past 3 years, to quote or perform State of Connecticut funded projects due to failure to comply with State Regulations or Statutes.
- M. The Bidder shall be a licensed Contractor authorized to do business in Connecticut and both hold a current Connecticut Tax Number and be current in its State taxes and local taxes, if any apply, in the Towns of Glastonbury at the time of bid.

## PART 2 – MATERIALS

### 2.1 CONTRACTOR QUALIFICATION QUESTIONNAIRE FORM

- A. A copy of the "Contractor Qualification Questionnaire" is attached.

## PART 3 – EXECUTION

3.1 ISSUANCE OF CONTRACTOR QUALIFICATION

- A. Prime Bidders MUST complete the following "CONTRACTOR QUALIFICATION QUESTIONNAIRE" and MUST include it with each Bid Proposal Form.

END OF SECTION



CONTRACTOR QUALIFICATION QUESTIONNAIRE

All prospective Contractors are required to complete this questionnaire and include it with the Bid Proposal.

The contents of this questionnaire will be considered confidential and used solely to determine Contractor's Qualifications and will not be disclosed to others.

I. General information

- A. Business Name:
B. Address:
C. Telephone Number:
Fax Number:
Email Address:
D. Contact Name and Title:
E. Applicable Related CSI code(s):
F. Are you listed in Dun & Bradstreet?
G. Is the Company Operation Union -or- Non-Union -or- both, please indicate here:
H. List Trade:

II. Organization

- A. Business type: Corporation Partnership Limited Liability Company Sole Proprietor Other (Specify)
B. Date Company Founded: State of Formation:
C. Please indicate the following information about all officers, managers and principals on a separate sheet: Full name, title, age and length of time in this position
D. List All other Names the Company has conducted operations under:
E. Is the Company Owned or Controlled by a Parent Company or any other Organization?
If Yes, please describe below:



---

---

---

F. Small Business Concern:  NO  YES

If Yes:

Disadvantaged Owned: \_\_\_\_\_

Women Owned: \_\_\_\_\_

Veteran Owned: \_\_\_\_\_

Service Disabled Veteran Owned: \_\_\_\_\_

HUB Zone: \_\_\_\_\_

M/WBE Status: \_\_\_\_\_

**III. Licensing information**

A. Provide All Trade and Professional Licenses, if any, held by the Company to perform work /services.

Type & Name of License	State	License number
_____	_____	_____
_____	_____	_____
_____	_____	_____
_____	_____	_____

B. Has any License ever been Denied -or- Revoked?  NO  YES

If yes, please describe below.

---

---

---

---

C. Has a Complaint ever been filed with a Contractor's State License Board against the Company within the last 5 years?

NO  YES, If Yes, please explain below briefly the circumstances & current status of complaint:

---

---

---

---

**IV. Work Experience**

A. Please **ATTACH a List of the Major Projects** the Company **has completed in the last three years** showing the project name, location, owner, architect/engineer, general contractor, contract amount and the completion date and contact person with telephone number.

**\*Include an ATTACHMENT as described above.**

B. Please **ATTACH a List of at least three (3) Projects during the past ten (10) years** in which the Contractor was able to meet rapid and critical schedules on major projects similar in size and complexity. Provide details of the contractor's ability to obtain material, workers, equipment, supervision and capital to meet such schedules in the past and for this project specifically.

**\*Include an ATTACHMENT as described above.**

C. What is the Company's average job size in dollars? \_\_\_\_\_

D. What was the largest job the Company ever completed in dollars? In what year? \_\_\_\_\_

What is the Company backlog in dollars? \_\_\_\_\_ As of today? \_\_\_\_\_

As of last financial statement? \_\_\_\_\_

As of 12 months ago? \_\_\_\_\_

E. Has the Company or any other organization with which the officers or owners were involved **during the past three years, ever failed to complete any work awarded or been terminated for cause?**

NO  YES, If yes, please provide a complete explanation.

---

---

F. **Are there any judgments, claims, arbitration proceedings, or suits pending/outstanding against the Company or its officers or principals?**  NO  YES, If yes, please provide a complete explanation.

---

---

G. Has the Company filed any lawsuits or requested arbitration or mediation with regard to construction contracts **within the last three years**?  NO  YES, If yes, please provide a complete disclosure of all past and pending mediation, arbitration and litigation cases that the Bidder or its Principals (regardless of their place of employment) have been involved in for the most recent five years. Please include a statement of the issues in dispute and their resolution. Acceptability of Bidder based on this disclosure shall lie solely with the Owner, Architect and Construction Manager.

**\*Include an ATTACHMENT as described above.**

H. Has the Company or any other organization with which the officers or owners were involved **during the past three years, ever been in bankruptcy or a voluntary or involuntary reorganization?**

NO  YES If yes, please provide a complete explanation.

---

---

I. Has the Surety ever finished one of the Company's construction projects?

NO  YES If yes, please provide a complete explanation.

---

---

**V. Financial information**

A. Please attach your company's most recent financial statement (audited, if available) for the entity that will be signing the contract.

B. Please indicate this year's **estimated** annual sales volume? \$ \_\_\_\_\_

C. Please indicate below the annual sales volume for the last three (3) years?

Year \_\_\_\_\_ \$ \_\_\_\_\_ Year \_\_\_\_\_ \$ \_\_\_\_\_ Year \_\_\_\_\_ \$ \_\_\_\_\_

D. Please provide the following financial information from the above financial statement:

Working Capital \$ \_\_\_\_\_ Net Worth \$ \_\_\_\_\_

Your Current ratio = current assets divided by current liabilities \_\_\_\_\_

Your Leverage ratio = total liabilities divided by net worth (defined as assets minus liabilities) \_\_\_\_\_

E. Please **ATTACH a LIST OF ALL MAJOR PROJECTS** the Company **Currently has in progress** indicate: (project name, location, owner, architect/engineer, general contractor, contract amount, percentage complete and scheduled completion date and contact person with telephone number).

**\*Include an ATTACHMENT as described above.**

**VI. References**

- A. Banking reference: \_\_\_\_\_
- B. Bonding reference:  
Bonding agent Name: \_\_\_\_\_  
Bonding agent Contact and Telephone: \_\_\_\_\_  
Bonding agent address: \_\_\_\_\_  
Bonding company: \_\_\_\_\_  
Surety's AM Best Rating: \_\_\_\_\_  
Bonding capacity: single limit \$ \_\_\_\_\_ total program bonding limit \$ \_\_\_\_\_

**VII. Safety and Health**

- A. Please List your Company's Workers Compensation interstate experience modification rate for the **most recent three years** (If available, please attach a copy of your insurance agent's verification letter).

Year _____	Experience Modification Rating _____
Year _____	Experience Modification Rating _____
Year _____	Experience Modification Rating _____

- B. Do you have a full-time safety representative?  NO  YES
- C. Has your firm had any OSHA fines or jobsite fatalities **within the last three years**?  
 NO  YES If yes, please describe in detail below.

\_\_\_\_\_

\_\_\_\_\_

- D. Please **ATTACH** copies of your Company's **OSHA No. 300 Log(s) for the most recent three years along with the most current log to date** of this submission.

**\*Include an ATTACHMENT as described above.**

- E. Please ATTACH copies of your Company's **OSHA Recordable Incident Rate and Lost Workday Incident Rate** for the **most recent three years including current year to date**.



THIS PAGE INTENTIONALLY LEFT BLANK

**PART 1 – GENERAL**

**1.1 NON-COLLUSION BIDDING AFFIDAVIT**

- A. All Bidders submitting a bid for any portion of the work contemplated by the documents on which bidding is based shall execute and attach to their Bid the Affidavit provided in the Project Manual stating, if true, that they have not colluded with any other person, firm, or corporation in regard to any bid submitted.
  
- B. A copy of the “East Hartford / Glastonbury Elementary Magnet School” Non-Collusion Bidding Affidavit is attached.

**PART 2 – MATERIALS**

Not Used

**PART 3 – EXECUTION**

Not Used

**END OF SECTION**

**EAST HARTFORD / GLASTONBURY  
ELEMENTARY MAGNET SCHOOL**

**NON COLLUSION BIDDING AFFIDAVIT**

No bid will be considered nor will any award be made to any Bidder who has not certified under penalties of perjury to the statement of non-collusion.

The undersigned and each person signing on behalf of the undersigned certified, under penalty of perjury, that:

- A. The prices in this bid have been arrived at independently, without collusion, consultation, communication or agreement, for the purpose of restricting competition, as to any matter relating to such prices with any other bidder or with any competitor;
- B. Unless otherwise required by law, the prices which have been quoted in this bid have not been knowingly disclosed by the undersigned and will not knowingly be disclosed by the undersigned prior to opening, directly or indirectly to any other bidder or to any competitor;
- C. No attempt has been or will be made by the undersigned to induce any other person, partnership or corporation to submit or not to submit a bid for the purpose of restricting competition.

Any bid containing a corporate Bidder's certification to the statement of non-collusion shall be deemed to have been authorized by the Board of Directors of the Bidder and such authorization shall be deemed to include the signing and submission of the bid and the inclusion therein of the certification as to non-collusion as the act and deed of the corporation.

By: \_\_\_\_\_ Title: \_\_\_\_\_

\_\_\_\_\_  
( Type in Name of Contractor)

Date: \_\_\_\_\_

**NOTE:** By Bidding on this Contract the Contractor agrees that any or all past clients may be contacted by the Town of Glastonbury or Architect. The Contractor bidding on this Contract also agrees to release and discharge by bidding on this Contract for the Contractor itself, its heirs, executors, administrators and assigns, does release, acquit and forever discharge the Town of Glastonbury, its Board of Education, the Construction Manager, Architect, CREC, and all employees and any or all other persons, firms and corporations of and from any and all actions, causes of actions, claims or demands, costs, loss of services, expenses, compensation, consequential damage or any other thing whatsoever, on account of, or in any way growing out of any former client contacted by the Town of Glastonbury or the Architect to obtain an opinion regarding any work performed by your Company. The above release shall also include and apply to any former client contacted.



Date

Contractor:

Project:

Obligee:

Bid Date:

To Whom It May Concern:

In the event that \_\_\_\_\_ is the successful low bidder and is awarded and  
(Contractor)  
enters into a contract for the above referenced project, subject to our normal underwriting  
functions, \_\_\_\_\_, as surety, is prepared to execute the  
(Surety Company)  
required performance and payment bonds.

Neither Principal nor surety shall be bound hereunder unless Obligee shall, prior to  
execution of the contract, furnish evidence satisfactory to the Surety of the Obligee's  
ability to make payment to the principal in accordance with the terms of the contract.

This letter is to be effective for the period ending ninety (90) days from bid date, unless  
extended by consent of Surety or Contractor.

\_\_\_\_\_  
(Surety Company)

\_\_\_\_\_  
(Contractor)

\_\_\_\_\_  
By: (Attorney in Fact)

\_\_\_\_\_  
By:

# DRAFT AIA<sup>®</sup> Document A312<sup>™</sup> - 1984

## Performance Bond

CONTRACTOR (Name and Address):

SURETY (Name and Principal Place of Business):

OWNER (Name and Address):

### CONSTRUCTION CONTRACT

Date:

Amount:

Description (Name and Location):

### BOND

Date (Not earlier than Construction Contract Date):

Amount:

Modifications to this Bond:  None  See Last Page

### CONTRACTOR AS PRINCIPAL

Company: (Corporate Seal)

Signature: \_\_\_\_\_

Name and \_\_\_\_\_,

Title:

(Any additional signatures appear on the last page)

### SURETY

Company: (Corporate Seal)

Signature: \_\_\_\_\_

Name and \_\_\_\_\_,

Title:

(FOR INFORMATION ONLY - Name, Address and Telephone)

AGENT or BROKER:

OWNER'S REPRESENTATIVE

(Architect, Engineer or other party):

### ADDITIONS AND DELETIONS:

The author of this document has added information needed for its completion. The author may also have revised the text of the original AIA standard form. An Additions and Deletions Report that notes added information as well as revisions to the standard form text is available from the author and should be reviewed.

This document has important legal consequences. Consultation with an attorney is encouraged with respect to its completion or modification.

Any singular reference to Contract, Surety, Owner or other party shall be considered plural where applicable.

**ELECTRONIC COPYING** of any portion of this AIA<sup>®</sup> Document to another electronic file is prohibited and constitutes a violation of copyright laws as set forth in the footer of this document.

§ 1 The Contractor and the Surety, jointly and severally, bind themselves, their heirs, executors, administrators, successors and assigns to the Owner for the performance of the Construction Contract, which is incorporated herein by reference.

§ 2 If the Contractor performs the Construction Contract, the Surety and the Contractor shall have no obligation under this Bond, except to participate in conferences as provided in Section 3.1.

§ 3 If there is no Owner Default, the Surety's obligation under this Bond shall arise after:

§ 3.1 The Owner has notified the Contractor and the Surety at its address described in Section 10 below that the Owner is considering declaring a Contractor Default and has requested and attempted to arrange a conference with the Contractor and the Surety to be held not later than fifteen days after receipt of such notice to discuss methods of performing the Construction Contract. If the Owner, the Contractor and the Surety agree, the Contractor shall be allowed a reasonable time to perform the Construction Contract, but such an agreement shall not waive the Owner's right, if any, subsequently to declare a Contractor Default; and

§ 3.2 The Owner has declared a Contractor Default and formally terminated the Contractor's right to complete the contract. Such Contractor Default shall not be declared earlier than twenty days after the Contractor and the Surety have received notice as provided in Section 3.1; and

§ 3.3 The Owner has agreed to pay the Balance of the Contract Price to the Surety in accordance with the terms of the Construction Contract or to a contractor selected to perform the Construction Contract in accordance with the terms of the contract with the Owner.

§ 4 When the Owner has satisfied the conditions of Section 3, the Surety shall promptly and at the Surety's expense take one of the following actions:

§ 4.1 Arrange for the Contractor, with consent of the Owner, to perform and complete the Construction Contract; or

§ 4.2 Undertake to perform and complete the Construction Contract itself, through its agents or through independent contractors; or

§ 4.3 Obtain bids or negotiated proposals from qualified contractors acceptable to the Owner for a contract for performance and completion of the Construction Contract, arrange for a contract to be prepared for execution by the Owner and the contractor selected with the Owner's concurrence, to be secured with performance and payment bonds executed by a qualified surety equivalent to the bonds issued on the Construction Contract, and pay to the Owner the amount of damages as described in Section 6 in excess of the Balance of the Contract Price incurred by the Owner resulting from the Contractor's default; or

§ 4.4 Waive its right to perform and complete, arrange for completion, or obtain a new contractor and with reasonable promptness under the circumstances:

- .1 After investigation, determine the amount for which it may be liable to the Owner and, as soon as practicable after the amount is determined, tender payment therefor to the Owner; or
- .2 Deny liability in whole or in part and notify the Owner citing reasons therefor.

§ 5 If the Surety does not proceed as provided in Section 4 with reasonable promptness, the Surety shall be deemed to be in default on this Bond fifteen days after receipt of an additional written notice from the Owner to the Surety demanding that the Surety perform its obligations under this Bond, and the Owner shall be entitled to enforce any remedy available to the Owner. If the Surety proceeds as provided in Section 4.4, and the Owner refuses the payment tendered or the Surety has denied liability, in whole or in part, without further notice the Owner shall be entitled to enforce any remedy available to the Owner.

§ 6 After the Owner has terminated the Contractor's right to complete the Construction Contract, and if the Surety elects to act under Section 4.1, 4.2, or 4.3 above, then the responsibilities of the Surety to the Owner shall not be greater than those of the Contractor under the Construction Contract, and the responsibilities of the Owner to the Surety shall not be greater than those of the Owner under the Construction Contract. To the limit of the amount of this Bond, but subject to commitment by the Owner of the Balance of the Contract Price to mitigation of costs and damages on the Construction Contract, the Surety is obligated without duplication for:

§ 6.1 The responsibilities of the Contractor for correction of defective work and completion of the Construction Contract;

§ 6.2 Additional legal, design professional and delay costs resulting from the Contractor's Default, and resulting from the actions or failure to act of the Surety under Section 4; and

§ 6.3 Liquidated damages, or if no liquidated damages are specified in the Construction Contract, actual damages caused by delayed performance or non-performance of the Contractor.

§ 7 The Surety shall not be liable to the Owner or others for obligations of the Contractor that are unrelated to the Construction Contract, and the Balance of the Contract Price shall not be reduced or set off on account of any such unrelated obligations. No right of action shall accrue on this Bond to any person or entity other than the Owner or its heirs, executors, administrators or successors.

§ 8 The Surety hereby waives notice of any change, including changes of time, to the Construction Contract or to related subcontracts, purchase orders and other obligations.

§ 9 Any proceeding, legal or equitable, under this Bond may be instituted in any court of competent jurisdiction in the location in which the work or part of the work is located and shall be instituted within two years after Contractor Default or within two years after the Contractor ceased working or within two years after the Surety refuses or fails to perform its obligations under this Bond, whichever occurs first. If the provisions of this Paragraph are void or prohibited by law, the minimum period of limitation available to sureties as a defense in the jurisdiction of the suit shall be applicable.

§ 10 Notice to the Surety, the Owner or the Contractor shall be mailed or delivered to the address shown on the signature page.

§ 11 When this Bond has been furnished to comply with a statutory or other legal requirement in the location where the construction was to be performed, any provision in this Bond conflicting with said statutory or legal requirement shall be deemed deleted here from and provisions conforming to such statutory or other legal requirement shall be deemed incorporated herein. The intent is that this Bond shall be construed as a statutory bond and not as a common law bond.

## § 12 DEFINITIONS

§ 12.1 Balance of the Contract Price: The total amount payable by the Owner to the Contractor under the Construction Contract after all proper adjustments have been made, including allowance to the Contractor of any amounts received or to be received by the Owner in settlement of insurance or other claims for damages to which the Contractor is entitled, reduced by all valid and proper payments made to or on behalf of the Contractor under the Construction Contract.

§ 12.2 Construction Contract: The agreement between the Owner and the Contractor identified on the signature page, including all Contract Documents and changes thereto.

§ 12.3 Contractor Default: Failure of the Contractor, which has neither been remedied nor waived, to perform or otherwise to comply with the terms of the Construction Contract.

§ 12.4 Owner Default: Failure of the Owner, which has neither been remedied nor waived, to pay the Contractor as required by the Construction Contract or to perform and complete or comply with the other terms thereof.

§ 13 MODIFICATIONS TO THIS BOND ARE AS FOLLOWS:

(Space is provided below for additional signatures of added parties, other than those appearing on the cover page.)

CONTRACTOR AS PRINCIPAL

Company: \_\_\_\_\_  
(Corporate Seal)

Signature: \_\_\_\_\_  
Name and Title: \_\_\_\_\_  
Address: \_\_\_\_\_

SURETY

Company: \_\_\_\_\_  
(Corporate Seal)

Signature: \_\_\_\_\_  
Name and Title: \_\_\_\_\_  
Address: \_\_\_\_\_

Payment Bond

CONTRACTOR (Name and Address):

[Redacted]

SURETY (Name and Principal Place of Business):

[Redacted]

OWNER (Name and Address):

[Redacted]

CONSTRUCTION CONTRACT

Date:

Amount:

Description (Name and Location):

[Redacted]

BOND

Date (Not earlier than Construction Contract Date):

Amount:

Modifications to this Bond:  None  See Last Page

CONTRACTOR AS PRINCIPAL

Company: (Corporate Seal)

SURETY

Company: (Corporate Seal)

Signature:

Name and Title:

(Any additional signatures appear on the last page)

[Redacted]

Signature:

Name and Title:

[Redacted]

(FOR INFORMATION ONLY - Name, Address and Telephone)

AGENT or BROKER:

[Redacted]

OWNER'S REPRESENTATIVE (Architect, Engineer or other party):

[Redacted]

§ 1 The Contractor and the Surety, jointly and severally bind themselves, their heirs, executors, administrators, successors and assigns to the Owner to pay for labor, materials and equipment furnished for use in the performance of the Construction Contract, which is incorporated herein by reference.

§ 2 With respect to the Owner, this obligation shall be null and void if the Contractor:

§ 2.1 Promptly makes payment, directly or indirectly, for all sums due Claimants, and

§ 2.2 Defends, indemnifies and holds harmless the Owner from claims, demands, liens or suits by any person or entity whose claim, demand, lien or suit is for the payment for labor, materials or equipment furnished for use in the performance of the Construction Contract, provided the Owner has promptly notified the Contractor and the Surety (at the address described in Section 12) of any claims, demands, liens or suits and tendered defense of such claims, demands, liens or suits to the Contractor and the Surety, and provided there is no Owner Default.

§ 3 With respect to Claimants, this obligation shall be null and void if the Contractor promptly makes payment, directly or indirectly, for all sums due.

§ 4 The Surety shall have no obligation to Claimants under this Bond until:

§ 4.1 Claimants who are employed by or have a direct contract with the Contractor have given notice to the Surety (at the address described in Section 12) and sent a copy, or notice thereof, to the Owner, stating that a claim is being made under this Bond and, with substantial accuracy, the amount of the claim.

§ 4.2 Claimants who do not have a direct contract with the Contractor:

- .1 Have furnished written notice to the Contractor and sent a copy, or notice thereof, to the Owner, within 90 days after having last performed labor or last furnished materials or equipment included in the claim stating, with substantial accuracy, the amount of the claim and the name of the party to whom the materials were furnished or supplied or for whom the labor was done or performed; and
- .2 Have either received a rejection in whole or in part from the Contractor, or not received within 30 days of furnishing the above notice any communication from the Contractor by which the Contractor has indicated the claim will be paid directly or indirectly; and
- .3 Not having been paid within the above 30 days, have sent a written notice to the Surety (at the address described in Section 12) and sent a copy, or notice thereof, to the Owner, stating that a claim is being made under this Bond and enclosing a copy of the previous written notice furnished to the Contractor.

§ 5 If a notice required by Section 4 is given by the Owner to the Contractor or to the Surety, that is sufficient compliance.

§ 6 When the Claimant has satisfied the conditions of Section 4, the Surety shall promptly and at the Surety's expense take the following actions:

§ 6.1 Send an answer to the Claimant, with a copy to the Owner, within 45 days after receipt of the claim, stating the amounts that are undisputed and the basis for challenging any amounts that are disputed.

§ 6.2 Pay or arrange for payment of any undisputed amounts.

§ 7 The Surety's total obligation shall not exceed the amount of this Bond, and the amount of this Bond shall be credited for any payments made in good faith by the Surety.

§ 8 Amounts owed by the Owner to the Contractor under the Construction Contract shall be used for the performance of the Construction Contract and to satisfy claims, if any, under any Construction Performance Bond. By the Contractor furnishing and the Owner accepting this Bond, they agree that all funds earned by the Contractor in the performance of the Construction Contract are dedicated to satisfy obligations of the Contractor and the Surety under this Bond, subject to the Owner's priority to use the funds for the completion of the work.

§ 9 The Surety shall not be liable to the Owner, Claimants or others for obligations of the Contractor that are unrelated to the Construction Contract. The Owner shall not be liable for payment of any costs or expenses of any Claimant under this Bond, and shall have under this Bond no obligations to make payments to, give notices on behalf of, or otherwise have obligations to Claimants under this Bond.

§ 10 The Surety hereby waives notice of any change, including changes of time, to the Construction Contract or to related subcontracts, purchase orders and other obligations.

§ 11 No suit or action shall be commenced by a Claimant under this Bond other than in a court of competent jurisdiction in the location in which the work or part of the work is located or after the expiration of one year from the date (1) on which the Claimant gave the notice required by Section 4.1 or Section 4.2.3, or (2) on which the last labor or service was performed by anyone or the last materials or equipment were furnished by anyone under the Construction Contract, whichever of (1) or (2) first occurs. If the provisions of this Paragraph are void or prohibited by law, the minimum period of limitation available to sureties as a defense in the jurisdiction of the suit shall be applicable.

§ 12 Notice to the Surety, the Owner or the Contractor shall be mailed or delivered to the address shown on the signature page. Actual receipt of notice by Surety, the Owner or the Contractor, however accomplished, shall be sufficient compliance as of the date received at the address shown on the signature page.

§ 13 When this Bond has been furnished to comply with a statutory or other legal requirement in the location where the construction was to be performed, any provision in this Bond conflicting with said statutory or legal requirement shall be deemed deleted herefrom and provisions conforming to such statutory or other legal requirement shall be deemed incorporated herein. The intent is that this Bond shall be construed as a statutory bond and not as a common law bond.

§ 14 Upon request by any person or entity appearing to be a potential beneficiary of this Bond, the Contractor shall promptly furnish a copy of this Bond or shall permit a copy to be made.

§ 15 DEFINITIONS

§ 15.1 Claimant: An individual or entity having a direct contract with the Contractor or with a subcontractor of the Contractor to furnish labor, materials or equipment for use in the performance of the Contract. The intent of this Bond shall be to include without limitation in the terms "labor, materials or equipment" that part of water, gas, power, light, heat, oil, gasoline, telephone service or rental equipment used in the Construction Contract, architectural and engineering services required for performance of the work of the Contractor and the Contractor's subcontractors, and all other items for which a mechanic's lien may be asserted in the jurisdiction where the labor, materials or equipment were furnished.

§ 15.2 Construction Contract: The agreement between the Owner and the Contractor identified on the signature page, including all Contract Documents and changes thereto.

§ 15.3 Owner Default: Failure of the Owner, which has neither been remedied nor waived, to pay the Contractor as required by the Construction Contract or to perform and complete or comply with the other terms thereof.

§ 16 MODIFICATIONS TO THIS BOND ARE AS FOLLOWS:

[Redacted]

*(Space is provided below for additional signatures of added parties, other than those appearing on the cover page.)*

**CONTRACTOR AS PRINCIPAL**

Company: (Corporate Seal)

Signature: \_\_\_\_\_  
Name and Title: [Redacted]  
Address: [Redacted]

**SURETY**

Company: (Corporate Seal)

Signature: \_\_\_\_\_  
Name and Title: [Redacted]  
Address: [Redacted]



THIS PAGE INTENTIONALLY LEFT BLANK

## PART 1 - GENERAL

## 1.1 PERFORMANCE AND PAYMENT BONDS

- A. The successful Bidder, **shall be required to furnish a Performance Bond and a Labor and Material Payment Bond each in the amount of 100% of the Contract price for any bid amount of \$50,000.00 or more** payable to the Owner for the full performance of the Contract and for the payment of all obligations arising here under on AIA Document 312, 1984 Edition, in a form satisfactory to the Owner.
- B. **If applicable Bidder SHALL FURNISH WITH THE BID FORM a Surety's Letter of Intent** to provide Performance and Payment Bonds if bidder is awarded the contract. \*NOTE, this Surety Letter of Intent SHALL NOT contain any significant qualifications or it may be rejected at the Owner or Architect's sole discretion.
- C. The Bonds, as well as the **Bid Bond** and **Surety's Letter of Intent**, must be provided by a Surety Company or Companies that meet the following qualifications as of the date of bid:
- a. Licensed to do business in the State of Connecticut and
  - b. Listed on the current U.S. Treasury "T" List and
  - c. Rated A or better by A.M. Best.

\*NOTE: The Bidder shall require that the attorney-in-fact who executes the required bonds on behalf of the surety affix thereto a certified, current copy of the appropriate power of attorney.

## PART 2 – MATERIALS

## 2.1 INCLUSION OF AIA DOCUMENT A312

- A. The Performance and Payment Bond Form, The American Institute of Architects Document A312, 1984 Edition, shall apply to and from a part of this section.
- B. A copy of the AIA Document A312 is attached.

## PART 3 – EXECUTION

### 3.1 ISSUANCE OF BONDS

- A. Within seven (7) days after the award of Contract, the successful Bidder **shall be required to furnish a Performance Bond and a Labor and Material Payment Bond each in the amount of 100% of the Contract price** payable to the Owner for the full performance of the Contract and for the payment of all obligations arising here under on AIA Document 312, 1984 Edition, in a form satisfactory

END OF SECTION

THIS PAGE INTENTIONALLY LEFT BLANK

# DRAFT AIA® Document A251™ - 2007

## General Conditions of the Contract for Furniture, Furnishings and Equipment

for the following PROJECT:  
(Name, location, and brief description)

«Blank»

<< >>  
<< >>

### THE OWNER:

(Name, legal status, address and other information)

<< >><< >>  
<< >>  
<< >>  
<< >>

### THE ARCHITECT:

(Name, legal status, address and other information)

<< >><< >>  
<< >>  
<< >>  
<< >>

### TABLE OF ARTICLES

- |    |  |
|----|--|
| 1  | GENERAL PROVISIONS                                 |
| 2  | OWNER  |
| 3  | VENDOR   |
| 4  | TITLE AND RISK OF LOSS                             |
| 5  | DELIVERY AND INSTALLATION                          |
| 6  | ACCEPTANCE   |
| 7  | WARRANTIES   |
| 8  | PAYMENT  |
| 9  | ARCHITECT  |
| 10 | RELATED ACTIVITIES OF OWNER OR OF SEPARATE VENDORS |
| 11 | TIME   |
| 12 | PROTECTION OF PERSONS AND PROPERTY                 |
| 13 | INSURANCE  |

#### ADDITIONS AND DELETIONS:

The author of this document has added information needed for its completion. The author may also have revised the text of the original AIA standard form. An *Additions and Deletions Report* that notes added information as well as revisions to the standard form text is available from the author and should be reviewed.

This document has important legal consequences. Consultation with an attorney is encouraged with respect to its completion or modification.

**ELECTRONIC COPYING** of any portion of this AIA® Document to another electronic file is prohibited and constitutes a violation of copyright laws as set forth in the footer of this document.

14 MISCELLANEOUS PROVISIONS

15 CLAIMS AND DISPUTES

ARTICLE 1 GENERAL PROVISIONS

§ 1.1 BASIC DEFINITIONS

§ 1.1.1 **The Contract Documents.** The Contract Documents are enumerated in the Agreement between the Owner and Vendor (hereinafter the Agreement), and consist of the Agreement, Conditions of the Contract (General, Supplementary and other Conditions), Drawings, Specifications, Addenda issued prior to execution of the Contract, other documents listed in the Agreement, and Modifications issued after execution of the Contract. Unless specifically enumerated in the Agreement, the Contract Documents do not include other documents such as the request for quotation or the Vendor's quotation.

§ 1.1.2 **Modification.** A Modification is (1) a written amendment to the Contract signed by both parties or (2) a written order for a minor change in the Work issued by the Architect.

§ 1.1.3 **The Contract.** The Contract Documents form the Contract for Furniture, Furnishings and Equipment. The Contract represents the entire and integrated agreement between the parties hereto and supersedes prior negotiations, representations or agreements, either written or oral. The Contract may be amended or modified only by a Modification. The Contract Documents shall not be construed to create a contractual relationship of any kind (1) between the Architect and the Vendor; (2) between the Owner and a sub-vendor; (3) between the Owner and the Architect or the Architect's consultants; or (4) between any persons or entities other than the Owner and the Vendor. The Architect shall, however, be entitled to performance and enforcement of obligations under the Contract intended to facilitate performance of the Architect's duties.

§ 1.1.4 **The Work.** The term "Work" means the fabrication, shipping, warehousing, delivery, installation and all other labor, materials and activities required of the Vendor. The Work may constitute the whole or a part of the Project with regard to the furniture, furnishings and equipment required by the Contract Documents.

§ 1.1.5 **The Project.** The Project is the total construction and installation of which the Work performed under the Contract may be the whole or a part. Other vendors and contractors under separate agreements with the Owner may concurrently perform construction or other activities for the Project.

§ 1.1.6 **The Drawings.** The Drawings are the graphic and pictorial portions of the Contract Documents showing the design, location and dimensions of the Work, generally including plans, elevations, sections, details, schedules and diagrams.

§ 1.1.7 **The Specifications.** The Specifications are that portion of the Contract Documents consisting of the written requirements for furniture, furnishings, equipment, systems, quality and workmanship standards for the Work.

§ 1.1.8 **Instruments of Service.** Instruments of Service are representations, in any medium of expression now known or later developed, of the tangible and intangible creative work performed by the Architect and the Architect's consultants under their respective professional services agreements. Instruments of Service may include, without limitation, studies, surveys, models, sketches, drawings, specifications, and other similar materials.

§ 1.2 CORRELATION AND INTENT OF THE CONTRACT DOCUMENTS

§ 1.2.1 The intent of the Contract Documents is to include all items necessary for the proper execution and completion of the Work by the Vendor. The Contract Documents are complementary, and what is required by one shall be as binding as if required by all; performance by the Vendor shall be required only to the extent consistent with the Contract Documents and reasonably inferable from them as being necessary to produce the indicated results.

§ 1.2.2 Unless otherwise stated in the Contract Documents, words that have well-known technical or furniture, furnishings and equipment industry meanings are used in the Contract Documents in accordance with such recognized meanings.

§ 1.2.3 Terms capitalized in these General Conditions include those which are (1) specifically defined, (2) the titles of numbered articles and identified references to Sections in the document or (3) the titles of other documents published by the American Institute of Architects.

### § 1.3 OWNERSHIP AND USE OF DRAWINGS, SPECIFICATIONS AND OTHER INSTRUMENTS OF SERVICE

§ 1.3.1 The Architect and the Architect's consultants shall be deemed the authors and owners of their respective Instruments of Service, including the Drawings and Specifications, and will retain all common law, statutory and other reserved rights, including copyrights. The Vendor, sub-vendors and suppliers shall not own or claim a copyright in the Instruments of Service. Submittal or distribution to meet official regulatory requirements or for other purposes in connection with this Project is not to be construed as publication in derogation of the Architect's or Architect's consultants' reserved rights.

§ 1.3.2 The Vendor, sub-vendors and suppliers are authorized to use and reproduce the Instruments of Service provided to them solely and exclusively for execution of the Work. All copies made under this authorization shall bear the copyright notice, if any, shown on the Instruments of Service. The Vendor, sub-vendors and suppliers may not use the Instruments of Service on other projects or for additions to this Project outside the scope of the Work without the specific written consent of the Owner, Architect and the Architect's consultants.

### § 1.4 TRANSMISSION OF DATA IN DIGITAL FORM

If the parties intend to transmit Instruments of Service or any other information or documentation in digital form, they shall endeavor to establish necessary protocols governing such transmissions, unless otherwise already provided in the Agreement or the Contract Documents.

## ARTICLE 2 OWNER

### § 2.1 GENERAL

The Owner is the person or entity identified as such in the Agreement and is referred to throughout the Contract Documents as if singular in number. The Owner shall designate in writing a representative who shall have express authority to bind the Owner with respect to all matters requiring the Owner's approval or authorization. Except as otherwise provided in Section 9.2.1, the Architect does not have such authority. The term "Owner" means the Owner or the Owner's authorized representative.

### § 2.2 INFORMATION AND SERVICES REQUIRED OF THE OWNER

§ 2.2.1 Unless otherwise provided in the Contract Documents, the Owner shall provide

- .1 areas of the Project premises that the Vendor may utilize in the performance of the Work;
- .2 access to the premises for the Vendor at reasonable times;
- .3 suitable space for receipt, inspection, acceptance and staging of materials, furniture, furnishings and equipment;
- .4 temporary utilities and facilities on the premises and vertical transportation necessary for progress and execution of the Work; and
- .5 security normal for the Project premises.

§ 2.2.2 The Owner shall furnish information or services required of the Owner by the Contract Documents with reasonable promptness. The Owner shall furnish any other information or services under the Owner's control and relevant to the Vendor's performance of the Work with reasonable promptness after receiving the Vendor's written request for such information or services.

## ARTICLE 3 VENDOR

### § 3.1 GENERAL

§ 3.1.1 The Vendor is the person or entity identified as such in the Agreement and is referred to throughout the Contract Documents as if singular in number. The term "Vendor" means the Vendor or the Vendor's authorized representative.

§ 3.1.2 The Vendor shall perform the Work in accordance with the Contract Documents.

§ 3.1.3 The Vendor shall not be relieved of obligations to perform the Work in accordance with the Contract Documents either by activities or duties of the Architect in the Architect's administration of the Contract or by tests, inspections or approvals required or performed by persons or entities other than the Vendor.

## § 3.2 REVIEW OF CONTRACT DOCUMENTS AND INSPECTION OF PROJECT PREMISES BY VENDOR

§ 3.2.1 Execution of the Contract by the Vendor is a representation that the Vendor has visited the Project premises or, if the Project premises have not yet been constructed, has reviewed the documents pertaining thereto; has become familiar with local conditions under which the Work is to be performed and information relative to access to and use of the Project premises, as provided by the Owner under Section 2.2; and has correlated personal observations with requirements of the Contract Documents.

§ 3.2.2 Because the Contract Documents are complementary, the Vendor shall, before starting each portion of the Work, (1) carefully study and compare the various Drawings and other Contract Documents relative to that portion of the Work, as well as the information furnished by the Owner pursuant to Section 2.2.1; (2) take field measurements of any existing conditions related to that portion of the Work; and (3) observe any conditions of the access route or on the Project premises affecting the Work. These obligations are for the purpose of facilitating delivery and installation by the Vendor and are not for the purpose of discovering errors, omissions or inconsistencies in the Contract Documents; however, the Vendor shall report promptly to the Architect any errors, inconsistencies or omissions discovered or made known to the Vendor as a request for information in such form as the Architect may require. It is recognized that the Vendor's review of the Contract Documents is made in the Vendor's capacity as a Vendor and not as a licensed design professional, unless otherwise specifically provided in the Contract Documents.

§ 3.2.3 The Vendor is not required to ascertain that the Contract Documents are in accordance with applicable laws, statutes, ordinances, codes, rules and regulations, or lawful orders of public authorities, but the Vendor shall report promptly to the Architect any nonconformity discovered by or made known to the Vendor as a request for information in such form as the Architect may require.

§ 3.2.4 In addition to the Vendor's representations under Section 3.2.1, the Vendor shall, prior to shipment, delivery and installation, visit and inspect the Project premises in order to confirm the conditions under which the Work is to be performed; verify the stage of completion of the premises and the Project; determine availability of facilities for access, delivery, transportation and staging area; determine the physical and environmental restrictions imposed by the Owner and the condition of the premises and separate vendors; and correlate these observations with the requirements of the Contract Documents. The Vendor shall promptly report to the Owner conditions observed during such inspection or thereafter that would impede the Vendor's performance of the Work.

§ 3.2.5 If the Vendor believes that additional cost or time is involved because of clarifications or instructions the Architect issues in response to the Vendor's notices or requests for information pursuant to Sections 3.2.2, 3.2.3 and 3.2.4, the Vendor shall make Claims as provided in Article 15. If the Vendor fails to perform the obligations of Sections 3.2.2, 3.2.3, or 3.2.4, the Vendor shall pay such costs and damages to the Owner as would have been avoided if the Vendor had performed such obligations.

## § 3.3 SUPERVISION OF THE WORK

§ 3.3.1 The Vendor shall supervise and direct the Work, using the Vendor's best skill and attention. The Vendor shall be solely responsible for and have control over the means, methods, techniques, sequences and procedures of fabrication, shipment, delivery and installation, and for coordinating all portions of the Work under the Contract, unless the Contract Documents give other specific instructions concerning these matters.

§ 3.3.2 The Vendor shall be responsible to the Owner for acts and omissions of the Vendor's employees, sub-vendors and their agents and employees, and other persons or entities performing or providing portions of the Work to, for or on behalf of, the Vendor or any of its sub-vendors.

§ 3.3.3 The Vendor shall be responsible for inspection of portions of Work already performed to determine that such portions are in proper condition for subsequent Work.

## § 3.4 LABOR AND MATERIALS

§ 3.4.1 Unless otherwise provided in the Contract Documents, the Vendor shall provide and pay for labor, materials, furniture, furnishings and equipment, tools, installation equipment and machinery, delivery, and other facilities and services necessary for proper execution and completion of the Work, whether temporary or permanent and whether or not incorporated or to be incorporated into the Work.



§ 3.4.2 The Vendor shall not make substitutions until after evaluation by the Architect and approval by the Owner.

§ 3.4.3 The Vendor shall enforce strict discipline and good order among the Vendor's employees and other persons carrying out the Work. The Vendor shall not permit employment of unfit persons or persons not properly skilled in tasks assigned to them.

### § 3.5 TAXES

The Vendor shall pay all required sales, consumer, use and similar taxes for the Work provided by the Vendor.

### § 3.6 PERMITS, FEES NOTICES, AND COMPLIANCE WITH LAWS

§ 3.6.1 Unless otherwise provided in the Contract Documents, the Vendor shall secure and pay for permits, fees, licenses and inspections by government agencies necessary for proper execution and completion of the Work that are customarily secured after execution of the Contract and legally required as of that date.

§ 3.6.2 The Vendor shall comply with and give notices required by applicable laws, statutes, ordinances, codes, rules and regulations, and lawful orders of public authorities applicable to performance of the Work.

§ 3.6.3 If the Vendor performs Work knowing it to be contrary to applicable laws, statutes, ordinances, codes, rules and regulations, or lawful orders of public authorities, the Vendor shall assume appropriate responsibility for such Work and shall bear the costs attributable to correction.

### § 3.7 SUPERINTENDENT

The Vendor shall employ a competent superintendent and necessary assistants who shall be in attendance at the Project premises during performance of the Work. The superintendent shall represent the Vendor, and communications given to the superintendent shall be as binding as if given to the Vendor.

### § 3.8 VENDOR'S SCHEDULES

§ 3.8.1 The Vendor, promptly after being awarded the Contract, shall prepare and submit for the Owner's and Architect's information a Vendor's progress schedule for the Work. The schedule shall not exceed time limits established in the Contract Documents, shall be revised at appropriate intervals as required by the conditions of the Work and the Project, shall be related to the Project and related Work to the extent required by the Contract Documents, and shall provide for expeditious and practicable execution of the Work.

§ 3.8.2 The Vendor's progress schedule shall indicate dates for commencement and completion of phases of the Work, within the Contract Time, including dates for order placement, fabrication, shipping, delivery and installation. The schedule shall indicate other critical dates, such as deadlines for approval of submittals of colors, finishes, fabrics and other materials. The Vendor shall obtain and submit for the Owner's and the Architect's information written confirmation from sub-vendors of dates of fabrication and delivery.

§ 3.8.3 The Vendor shall prepare a submittal schedule, promptly after being awarded the Contract and thereafter as necessary to maintain a current submittal schedule, and shall submit the schedule(s) for the Architect's approval. The Architect's approval shall not be unreasonably delayed or withheld. The submittal schedule shall 1) be coordinated with the Vendor's progress schedule, and 2) allow the Architect reasonable time to review submittals. If the Vendor fails to submit a submittal schedule, the Vendor shall not be entitled to any increase in Contract Sum or extension of contract completion time based on the time required for review of submittals.

§ 3.8.4 The Vendor shall perform the Work in accordance with the most recent schedules submitted to the Owner and Architect.

§ 3.8.5 The Vendor shall cooperate with the Owner and Architect in coordinating the Vendor's progress schedule with those of separate Vendors and with the requirements of the Owner and Architect. The Vendor shall cooperate in determining mutually acceptable dates and times for delivery, installation and inspection of the Work, and use of services and facilities provided to the Vendor, all to be confirmed in writing within a reasonable time in advance of such dates and times.

### § 3.9 DOCUMENTS FOR THE OWNER'S RECORDS

The Vendor shall maintain for the Owner one copy of the Drawings, Specifications, Addenda and other Modifications, in good order and marked currently to indicate field changes and selections made during performance of the Work, and one copy of approved Shop Drawings, Product Data and similar required submittals. These shall be available to the Architect and shall be delivered to the Owner upon completion of the Work as a record of the Work installed.

### § 3.10 SHOP DRAWINGS, PRODUCT DATA AND SAMPLES

§ 3.10.1 Shop Drawings are drawings, diagrams, schedules and other data specially prepared for the Work by the Vendor or a sub-vendor to illustrate some portion of the Work.

§ 3.10.2 Product Data are manufacturer's illustrations, standard schedules, performance charts, instructions, brochures, diagrams and other information furnished by the Vendor to illustrate materials or equipment for some portion of the Work.

§ 3.10.3 Shop Drawings, Product Data and similar submittals are not Contract Documents. Their purpose is to demonstrate the way by which the Vendor proposes to conform to the information given and the design concept expressed in the Contract Documents. Informational submittals upon which the Architect is not expected to take responsive action may be so identified in the Contract Documents. The Architect may return without action submittals that are not required by the Contract Documents.

§ 3.10.4 The Vendor shall review for compliance with the Contract Documents, and approve and submit to the Architect, Shop Drawings, Product Data and similar submittals required by the Contract Documents in accordance with the submittal schedule approved by the Architect or, in the absence of an approved submitted schedule, with reasonable promptness and in such sequence as to cause no delay in the Work or in the activities of the Owner or of separate vendors.

§ 3.10.5 By submitting Shop Drawings, Product Data and similar submittals, the Vendor represents to the Owner and Architect that the Vendor has (1) reviewed and approved them, and (2) determined and verified materials, field measurements and field installation criteria related thereto, or will do so, and (3) checked and coordinated the information contained within such submittals with the requirements of the Work and of the Contract Documents.

§ 3.10.6 The Vendor shall perform no portion of the Work for which the Contract Documents require submittal and review of Shop Drawings, Product Data or similar submittals until the respective submittal has been approved by the Architect.

§ 3.10.7 The Work shall be in accordance with approved submittals, except that the Vendor shall not be relieved of responsibility for deviations from requirements of the Contract Documents by the Architect's approval of Shop Drawings, Product Data or similar submittals unless the Vendor has specifically informed the Architect in writing of such deviation at the time of submittal and (1) the Architect has given written approval to the specific deviation as a minor change in the Work or (2) a Modification to the Contract has been approved authorizing the deviation. The Vendor shall not be relieved of responsibility for errors or omissions in Shop Drawings, Product Data or similar submittals by the Architect's approval.

§ 3.10.8 The Vendor shall direct specific attention, in writing or on resubmitted Shop Drawings, Product Data or similar submittals, to revisions other than those requested by the Architect on previous submittals. In the absence of such written notice, the Architect's approval of a resubmission shall not apply to such revisions.

§ 3.10.9 Samples, once approved, constitute an express warranty that the goods will conform to the sample.

§ 3.10.10 When professional certification of performance criteria for furniture, furnishings and equipment is required by the Contract Documents, the Architect shall be entitled to rely upon the accuracy and completeness of such certifications.

### § 3.11 CLEANING UP

§ 3.11.1 The Vendor shall keep the premises and surrounding area free from accumulation of waste materials and other debris created by operations under the Contract. At completion of the Work, the Vendor shall remove waste

materials and other debris created by the Vendor's activities, the Vendor's tools, construction equipment, machinery and surplus materials from and about the Project.

§ 3.11.2 If the Vendor fails to clean up as provided in the Contract Documents, the Owner may do so, and the Owner shall be entitled to reimbursement from the Vendor for the cost thereof.

### § 3.12 INDEMNIFICATION

§ 3.12.1 To the fullest extent permitted by law, the Vendor shall indemnify and hold harmless the Owner, Architect, Architect's consultants, and agents and employees of any of them from and against claims, damages, losses and expenses, including but not limited to attorneys' fees, arising out of or resulting from performance of the Work, provided that such claim, damage, loss or expense is attributable to bodily injury, sickness, disease or death, or to injury to or destruction of tangible property (other than the Work itself), but only to the extent caused by the negligent acts or omissions of the Vendor, a sub-vendor, anyone directly or indirectly employed by them or anyone for whose acts they may be liable, regardless of whether or not such claim, damage, loss or expense is caused in part by a party indemnified hereunder. Such obligation shall not be construed to negate, abridge or reduce other rights or obligations of indemnity which would otherwise exist as to a party or person described in this Section 3.12.

§ 3.12.2 In claims against any person or entity indemnified under this Section 3.12 by an employee of the Vendor, a sub-vendor, anyone directly or indirectly employed by them or anyone for whose acts they may be liable, the indemnification obligation under Section 3.12.1 shall not be limited by a limitation on amount or type of damages, compensation or benefits payable by or for the Vendor or a sub-vendor under workers' compensation acts, disability benefit acts or other employee benefit acts.

### ARTICLE 4 TITLE AND RISK OF LOSS

§ 4.1 Title to all furniture, furnishings and equipment shall be transferred to the Owner upon acceptance by the Owner pursuant to Section 6.2 or upon payment in full to the Vendor, whichever occurs first.

§ 4.2 The risk of loss, with respect to all furniture, furnishings and equipment provided by the Vendor, shall remain on the Vendor until acceptance by the Owner pursuant to Section 6.2 of the furniture, furnishings and equipment, or designated portion thereof.

§ 4.3 The Owner shall be under no obligation to insure furniture, furnishings or equipment that does not conform to the Contract Documents or that the Owner has rejected. Under such circumstances, the risk of loss shall remain with the Vendor.

### ARTICLE 5 DELIVERY AND INSTALLATION

§ 5.1 The Vendor shall make delivery of all furniture, furnishings and equipment in accordance with the Vendor's progress schedule or at a time agreed upon by the Owner and Architect.

§ 5.2 The Vendor shall become fully informed of the conditions relating to delivery, installation and labor under which the Vendor's Work will be performed. The Vendor shall employ the labor, and means and methods of carrying out the Vendor's Work as the conditions require.

§ 5.3 Delivery and installation of all furniture, furnishings and equipment shall be made to the location of the Project, as specified in the Contract Documents. Installation of furniture, furnishings and equipment shall include testing as required by the Contract Documents.

§ 5.4 The Vendor shall consult with the Owner to identify a route to be used within the Project premises from the point of initial delivery at the Project premises to the place of final placement or installation. After its selection, the route shall be made available to the Vendor for delivery of furniture, furnishings and equipment as provided in Section 5.1 and Section 5.2.

§ 5.5 The Vendor shall, within a reasonable time prior to delivery, provide the Owner with schedules for access and arrange for the use of elevators and unloading facilities.

§ 5.6 When the Vendor considers installation of all or a designated portion of the furniture, furnishings or equipment required by the Contract Documents to be complete, the Vendor shall advise the Owner and Architect in writing.

## ARTICLE 6 ACCEPTANCE

§ 6.1 Prior to the tender of delivery by the Vendor, the Owner may conduct a preliminary inspection of the furniture, furnishings and equipment upon delivery for the purpose of verifying the delivery of such furniture, furnishings or equipment, including quantities. Such preliminary inspections shall not constitute acceptance of, taking charge over or control of such furniture, furnishings or equipment. Any defects, damage, deficiencies or nonconformity discovered by the Owner shall be reported to the Vendor.

§ 6.2 Upon completion of installation pursuant to Section 5.6, the Owner, with the assistance of the Architect, shall conduct an acceptance inspection. If the Owner determines that the furniture, furnishings and equipment comply with the requirements of the Contract Documents, the Owner shall notify the Vendor that the furniture, furnishings and equipment have been accepted. If the Owner determines that all or any portion of the furniture, furnishings or equipment do not conform to the requirements of the Contract Documents, the Owner shall reject such nonconforming portion by notifying the Vendor in writing of such rejection.

§ 6.3 If the Owner rejects all or any portion of the delivery, the Owner shall notify the Vendor within a reasonable time, which shall not be more than 30 days after the date of the inspection performed pursuant to Section 6.2. The notice shall include the specific basis for the Owner's rejection.

§ 6.4 If the Owner rejects all or any portion of the delivery, the Owner shall hold the rejected portion for a reasonable time to permit the Vendor to remove it from the Project premises.

§ 6.5 Upon rejection by the Owner, the Vendor shall have 30 days to provide acceptable evidence of arrangements to remedy the basis for rejection. If the Vendor remedies the basis for rejection, the Vendor shall notify the Owner in writing. The Owner shall have an additional period of time to conduct an acceptance inspection of the previously rejected furniture, furnishings or equipment. If the Owner agrees to accept the furniture, furnishings or equipment, the Owner shall so notify the Vendor in writing. If the Owner rejects the tender of such furniture, furnishings or equipment, the Owner shall notify the Vendor within a reasonable time, which shall not be more than 30 days. Such notice shall include the specific basis for rejection. Upon rejection, the Vendor shall remove the rejected furniture, furnishings or equipment from the Project premises.

§ 6.6 If furniture, furnishings or equipment that have been previously accepted are found not to comply with the requirements of the Contract Documents, the Owner shall be entitled to revoke acceptance so long as the Vendor does not suffer actual prejudice by virtue of the Owner's prior acceptance of such furniture, furnishings or equipment. Such revocation of acceptance shall be made by giving prompt notice to the Vendor. In such event, the Vendor shall proceed in accordance with Section 6.5.

§ 6.7 The provisions of this Article 6 do not preclude recovery of damages as provided by law.

## ARTICLE 7 WARRANTIES

§ 7.1 The Vendor expressly warrants to the Owner and Architect that the Work complies with the requirements of the Contract Documents. The Vendor further warrants that the Owner shall receive the benefit of standard manufacturer's warranties and guarantees applicable to the Work.

§ 7.2 The Vendor provides to the Owner and Architect all warranties relating to the furniture, furnishings and equipment implied by law, including but not limited to the warranty of merchantability.

§ 7.3 The Vendor acknowledges that no exclusion of or limitation on warranties contained in any proposal, product literature or other submittal shall affect the warranties provided pursuant to Sections 7.1 and 7.2.

## ARTICLE 8 PAYMENT

§ 8.1 Before the first application for payment, the Vendor shall submit to the Owner a quotation schedule showing the values allocated to each quotation for portions of the Work. The Vendor's quotation schedule shall be accompanied by a certified statement from the Vendor prepared in such form and supported by such data to substantiate its accuracy as the Owner may require. This schedule, when approved by the Owner, shall be submitted with each application for payment and shall be used as a basis for reviewing the Vendor's applications for payment.

§ 8.2 When payment is due pursuant to the payment terms of the Agreement, the Vendor shall submit to the Owner an itemized application for payment. Such application shall be notarized, if required by the Contract Documents, and supported by such data substantiating the Vendor's right to payment as the Owner may require, such as copies of bills of lading or requisitions from sub-vendors and equipment suppliers.

## ARTICLE 9 ARCHITECT

### § 9.1 GENERAL

The Owner shall retain an architect lawfully licensed to practice architecture or an entity lawfully practicing architecture in the jurisdiction where the Project is located. That person or entity is identified as the Architect in the Agreement and is referred to throughout the Contract Documents as if singular in number.

### § 9.2 ADMINISTRATION OF THE CONTRACT

§ 9.2.1 The Architect will provide administration of the Contract as described in the Contract Documents and will be an Owner's representative during performance of the Work until final payment is due. The Architect will have authority to act on behalf of the Owner only to the extent provided in the Contract Documents, unless otherwise modified in writing in accordance with other provisions of the Contract.

§ 9.2.2 The Architect will assist the Owner in coordinating schedules for fabrication, delivery and installation of the Work, but will not be responsible for failure of the Vendor or a sub-vendor to meet schedules for completion or to perform their respective duties and responsibilities in conformance with such schedules.

§ 9.2.3 The Architect will visit the Project premises at intervals appropriate to the stage of the Vendor's operations, or as otherwise agreed with the Owner, to become generally familiar with the progress and quality of the portion of the Work completed; and to determine in general if the Work observed is being performed in a manner indicating that the Work, when fully completed, will be in accordance with the Contract Documents. However, the Architect will not be required to make exhaustive or continuous inspections at the Project premises to check the quality or quantity of the Work. The Architect will not have control over, charge of, or responsibility for, the means, methods, techniques, and sequences or procedures of fabrication, shipment, delivery or installation, or for the safety precautions and programs in connection with the Work, since these are solely the Vendor's rights and responsibilities under the Contract Documents, except as provided in Section 3.3.1.

§ 9.2.4 On the basis of the site visits, the Architect will keep the Owner reasonably informed about the progress and quality of the portion of the Work completed, and report to the Owner (1) known deviations from the Contract Documents and from the most recent construction schedule submitted by the Contractor, and (2) defects and deficiencies observed in the Work. The Architect will not be responsible for the Vendor's failure to perform the Work in accordance with the requirements of the Contract Documents. The Architect shall not have control over, charge of, or responsibility for acts or omissions of the Vendor, sub-vendors, their agents or employees, or any other persons or entities performing portions of the Work.

§ 9.2.5 The Architect has authority to order minor changes in the Work not involving an adjustment in the Contract Sum or an extension of the completion time, and not inconsistent with the intent of the Contract Documents. Such changes shall be effected by written order and shall be binding on the Owner and Vendor. The Vendor shall carry out such written orders promptly.

§ 9.2.6 Unless otherwise provided, the Architect's authority shall not extend to the receipt, inspection or acceptance on behalf of the Owner of furniture, furnishings and equipment at the time of their delivery to the Project premises and subsequent installation. The Architect is not authorized to reject nonconforming Work, stop the Work or terminate the Contract.

§ 9.2.7 The Architect may recommend to the Owner rejection of Work that does not conform to the Contract Documents. A recommendation by the Architect made in good faith shall not give rise to a duty or responsibility of the Architect to the Owner, Vendor, sub-vendors, their agents or employees, or other persons or entities performing portions of the Work.



## ARTICLE 10 RELATED ACTIVITIES OF OWNER OR OF SEPARATE VENDORS

### § 10.1 OWNER'S RIGHT TO PERFORM RELATED ACTIVITIES AND TO AWARD SEPARATE CONTRACTS

§ 10.1.1 The Owner reserves the right to perform activities related to the Project with the Owner's own forces, and to award separate contracts in connection with other portions of the Project or other activities at the Project premises. If the Vendor claims that such action by the Owner involves delay or additional cost, the Vendor shall make such Claim as provided in Article 15.

§ 10.1.2 When separate contracts are awarded for different portions of the Project or other activities at the Project premises, the term "Vendor" in the Contract Documents in each case shall mean the vendor who executes each separate Owner-Vendor Agreement.

§ 10.1.3 The Owner shall provide for coordination of the activities of the Owner's own forces and of each separate vendor with the Work of the Vendor, who shall cooperate with them. The Vendor shall participate with other separate vendors and the Owner in reviewing their progress schedules. The Vendor shall make any revisions to the progress schedule deemed necessary after a joint review and mutual agreement. The progress schedules shall then constitute the schedules to be used by the Vendor, separate vendors and the Owner until subsequently revised.

§ 10.1.4 Unless otherwise provided in the Contract Documents, when the Owner performs activities related to the Project with the Owner's own forces, the Owner shall be deemed to be subject to the same obligations and to have the same rights that apply to the Vendor under the Contract, including, without excluding others, those stated in this Article 10, and in Article 3, Article 12 and Article 13 herein.

### § 10.2 MUTUAL RESPONSIBILITY

§ 10.2.1 The Vendor shall afford the Owner and separate vendors reasonable opportunity for introduction and storage of their materials and equipment and performance of their activities, and shall connect and coordinate the Vendor's activities with theirs as required by the Contract Documents.

§ 10.2.2 If part of the Vendor's Work depends for proper execution or results upon activities by the Owner or a separate vendor, the Vendor shall, prior to proceeding with that portion of the Work, promptly report to the Architect apparent discrepancies or defects resulting from their activities that would impede the Vendor in achieving proper execution and results. If the Vendor fails to report discrepancies or defects reasonably discoverable, it shall be responsible for deficiencies or defects in its Work due to such deficiencies or defects.

§ 10.2.3 The Vendor shall reimburse the Owner for costs the Owner incurs that are payable to a separate vendor because of the Vendor's delays, improperly timed activities or other damage to the Work of a separate vendor. The Owner shall be responsible to the Vendor for costs the Vendor incurs because of the delays, improperly timed activities or damage to the Work caused by a separate vendor.

§ 10.2.4 The Vendor shall promptly remedy damage it wrongfully causes to property of the Owner or separate vendors as provided in Section 12.2.4.

### § 10.3 OWNER'S RIGHT TO CLEAN UP

If a dispute arises among the Vendor, separate vendors and the Owner as to the responsibility under their respective contracts for maintaining the premises and surrounding area free from waste materials and rubbish, the Owner may clean up and, with the Architect's assistance, allocate the cost among those responsible.

## ARTICLE 11 TIME

### § 11.1 DEFINITION OF DAY

The term "day" as used in the Contract Documents shall mean calendar day unless otherwise specifically defined.

### § 11.2 PROGRESS AND COMPLETION

§ 11.2.1 Time limits stated in the Contract Documents are of the essence of the Contract. By executing the Agreement, the Vendor confirms that the completion date stated in the Contract Documents provides a reasonable period for performing the Work.

§ 11.2.2 The Vendor shall not knowingly, except by agreement or instruction of the Owner in writing, prematurely commence operations on the Project premises prior to the effective date of insurance required by Article 13 to be

furnished by the Vendor and the Owner. The date of commencement of the Work shall not be changed by the effective date of such insurance.

§ 11.2.3 The Vendor shall proceed expeditiously with adequate forces and shall achieve completion by the mutually agreed upon completion date.

### § 11.3 DELAYS AND EXTENSIONS OF TIME

§ 11.3.1 If the Vendor is delayed at any time in the commencement or progress of the Work by an act or neglect of the Owner or Architect; or by changes ordered in the Work; or by labor disputes, fire, unusual delay in deliveries, unavoidable casualties or other causes beyond the Vendor's control; or by delay authorized by the Owner pending mediation and arbitration; or by other causes which the Architect determines may justify delay, the completion date shall be extended by mutual agreement between the Owner and the Vendor.

### § 11.3.2 CONFORMANCE TO AGREED-UPON SCHEDULES

§ 11.3.2.1 The Owner shall cooperate and coordinate its activities with the agreed-upon critical dates identified in the Vendor's progress schedule provided under Section 3.8.2.

§ 11.3.2.2 The Owner shall be responsible for costs the Vendor incurs, such as demurrage, warehousing, and storage or delivery charges, that are due to the Owner's failure to conform to the mutually agreed-upon progress schedule for the Work; to the Owner's failure, without justification, to accept delivery or final installation of furniture, furnishings and equipment; or to any other delays for which the Owner is responsible.

§ 11.3.3 Claims relating to time shall be made in accordance with applicable provisions of Article 15.

§ 11.3.4 This Section 11.3 does not preclude recovery of damages for delay by either party under other provisions of the Contract Documents.

## ARTICLE 12 PROTECTION OF PERSONS AND PROPERTY

### § 12.1 SAFETY PRECAUTIONS AND PROGRAMS

The Vendor shall be solely responsible for initiating, maintaining and supervising all safety precautions and programs in connection with the performance of the Contract.

### § 12.2 SAFETY OF PERSONS AND PROTECTION OF PROPERTY

§ 12.2.1 The Vendor shall take reasonable precautions for safety of, and shall provide reasonable protection to prevent damage, injury or loss to

- .1 employees on the Work and other persons who may be affected thereby;
- .2 the Work and materials, furniture, furnishings and equipment to be incorporated therein, whether in storage on or off the Project premises, under care, custody or control of the Vendor or sub-vendors; and
- .3 other property at the Project premises or adjacent thereto, including property of the Owner, separate vendors or other persons, whether or not completed or installed.

§ 12.2.2 The Vendor shall comply with and give notices required by applicable laws, statutes, ordinances, codes, rules and regulations, and lawful orders of public authorities bearing on safety of persons or property or their protection from damage, injury or loss.

§ 12.2.3 When use or storage of flammable, volatile or other hazardous materials or equipment or unusual methods are necessary for execution of the Work, the Vendor shall exercise utmost care and carry on such activities under supervision of properly qualified personnel.

§ 12.2.4 The Vendor shall promptly remedy damage and loss to property, other than damage to the Work, caused in whole or in part by the Vendor or anyone directly or indirectly employed by the Vendor, except damage or loss attributable to acts or omissions of the Owner or Architect or anyone directly or indirectly employed by either of them, or by anyone for whose acts either of them may be liable, and not attributable to the fault or negligence of the Vendor.

## ARTICLE 13 INSURANCE

### § 13.1 VENDOR'S LIABILITY INSURANCE

§ 13.1.1 The Vendor shall purchase from and maintain in a company or companies lawfully authorized to do business in the jurisdiction in which the Project is located such insurance as will protect the Vendor from claims set forth below which may arise out of or result from the Vendor's operations and completed operations under the Contract and for which the Vendor may be legally liable, whether such operations be by the Vendor, by a sub-vendor, by anyone directly or indirectly employed by any of them, or by anyone for whose acts any of them may be liable:

- .1 Claims under workers' compensation, disability benefit and other similar employee benefit acts which are applicable to the Work to be performed;
- .2 Claims for damages because of bodily injury, occupational sickness or disease, or death of the Vendor's employees;
- .3 Claims for damages because of bodily injury, sickness or disease, or death of any person other than the Vendor's employees;
- .4 Claims for damages insured by usual personal injury liability coverage;
- .5 Claims for damages, other than to the Work itself, because of injury to, or destruction of, tangible property, including loss of use resulting therefrom;
- .6 Claims for damages because of bodily injury, death of a person or property damage arising out of ownership, maintenance or use of a motor vehicle;
- .7 Claims for bodily injury or property damage arising out of completed operations;
- .8 Claims involving contractual liability insurance applicable to the Vendor's obligations under Section 3.12.1; and
- .9 Claims for products liability and completed-operations insurance.

§ 13.1.2 The insurance required by Section 13.1.1 shall be written for not less than the limits of liability specified in the Contract Documents or required by law, whichever coverage is greater. Coverages, whether written on an occurrence or claims-made basis, shall be maintained without interruption from the date of commencement of the Work until the date of final payment and termination of any coverage required to be maintained after final payment, and with respect to the Contractor's completed operations coverage, until the expiration of the period specified in the Contract Documents.

§ 13.1.3 Certificates of insurance acceptable to the Owner shall be filed with the Owner prior to commencement of the Work and thereafter upon renewal or replacement of each required policy of insurance. These certificates and the insurance policies required by Section 13.1.1 shall contain a provision that coverages afforded under the policies will not be canceled or allowed to expire until at least 30 days' prior written notice has been given to the Owner. An additional certificate evidencing continuation of liability coverage including coverage for completed operations shall be submitted with the final application for payment and thereafter upon renewal or replacement of such coverage until the expiration of the time required by Section 13.1.2. The Vendor shall provide information concerning reduction of coverage on account of revised limits or claims paid under the general aggregate, or both, with reasonable promptness.

## ARTICLE 14 MISCELLANEOUS PROVISIONS

### § 14.1 GOVERNING LAW

This Agreement shall be considered to be for sale of goods and shall be governed by the Uniform Commercial Code (UCC) as adopted in the place where the Project is located. The Contract shall be governed by the law of the place where the Project is located, except, that if the parties have selected arbitration as the method of binding dispute resolution, the Federal Arbitration Act shall govern Section 9.6.

### § 14.2 SUCCESSORS AND ASSIGNS

The Owner and Vendor respectively bind themselves, their partners, successors, assigns and legal representatives to covenants, agreements and obligations contained in the Contract Documents. Neither party to the Contract shall assign the Contract as a whole without written consent of the other. If either party attempts to make such an assignment without such consent, that party shall nevertheless remain legally responsible for all obligations under the Contract.



## ARTICLE 15 CLAIMS AND DISPUTES

**§ 15.1 Definition.** A Claim is a demand or assertion by one of the parties seeking, as a matter of right, payment of money or other relief with respect to the terms of the Contract. The term "Claim" also includes other disputes and matters in question between the Owner and Vendor arising out of or relating to the Contract. The responsibility to substantiate Claims shall rest with the party making the Claim.

**§ 15.1.1 Notice of Claims.** Claims by either party must be initiated by written notice to the other party within 21 days after occurrence of the event giving rise to such Claim or within 21 days after the claimant first recognizes the condition giving rise to the Claim, whichever is later.

**§ 15.1.2 Continuing Contract Performance.** Pending final resolution of a Claim, the Vendor shall proceed diligently with performance of the Contract, and the Owner shall continue to make payments in accordance with the Contract Documents.

**§ 15.1.3 Claims for Consequential Damages.** The Vendor and Owner waive Claims against each other for consequential damages arising out of or relating to this Contract. This mutual waiver includes

- .1 damages incurred by the Owner for rental expenses, losses of use, income, profit, financing, business and reputation, and for loss of management or employee productivity or of the services of such persons; and
- .2 damages incurred by the Vendor for principal office expenses, including the compensation of personnel stationed there; for losses of financing, business and reputation; and for loss of profit, except anticipated profit arising directly from the Work. Nothing contained in this Section 15.1.3 shall be deemed to preclude an award of liquidated damages, when applicable, in accordance with the requirements of the Contract Documents.

## § 15.2 RESOLUTION OF CLAIMS AND DISPUTES

Claims, including those alleging an error or omission by the Architect, shall be referred initially to the Architect. An initial recommendation in writing by the Architect, followed by negotiation of the parties, shall be required as a condition precedent to mediation, arbitration or litigation of all Claims between the Vendor and Owner arising prior to the date final payment is due, unless 30 days have passed after the Claim has been referred to the Architect with no recommendation having been made by the Architect.

## § 15.3 MEDIATION

**§ 15.3.1** Any Claim arising out of or related to the Contract, except Claims relating to aesthetic effect and except those waived as provided for in Section 15.1.3, shall, after recommendation by the Architect or 30 days after submission of the Claim to the Architect, be subject to mediation as a condition precedent to arbitration or the institution of legal or equitable proceedings by either party.

**§ 15.3.2** The parties shall endeavor to resolve their Claims by mediation, which, unless the parties mutually agree otherwise, shall be administered by the American Arbitration Association in accordance with its Construction Mediation Procedures in effect on the date of the Agreement. A request for mediation shall be made in writing, delivered to the other party to the Contract, and filed with the person or entity administering the mediation. The request may be made concurrently with the filing of a demand for arbitration, which shall be stayed pending mediation for a period of 60 days from the date of filing, unless stayed for a longer period by agreement of the parties or court order. If an arbitration is stayed pursuant to this Section, the parties may nonetheless proceed to the selection of the arbitrator(s) and agree upon a schedule for later proceedings.

**§ 15.3.3** The parties shall share the mediator's fee and any filing fees equally. The mediation shall be held in the place where the Project is located, unless another location is mutually agreed upon. Agreements reached in mediation shall be enforceable as settlement agreements in any court having jurisdiction thereof.

## § 15.4 ARBITRATION

**§ 15.4.1** Any Claim subject to, but not resolved by, mediation pursuant to Section 15.3 shall be subject to arbitration which, unless the parties mutually agree otherwise, shall be administered by the American Arbitration Association in accordance with its Construction Industry Arbitration Rules in effect on the date of the Agreement. A demand for arbitration shall be made in writing, delivered to the other party to the Contract, and filed with the person or entity

administering the arbitration. The party filing a notice of demand for arbitration must assert in the demand all Claims then known to that party on which arbitration is permitted to be demanded.

§ 15.4.1.1 A demand for arbitration shall be made no earlier than concurrently with the filing of a request for mediation, but in no event shall it be made after the date when the institution of legal or equitable proceedings based on such Claim would be barred by the applicable statute of limitations. For statute of limitations purposes, receipt of a written demand for arbitration by the person or entity administering the arbitration shall constitute the institution of legal or equitable proceedings based on the Claim.

§ 15.4.2 The award rendered by the arbitrator or arbitrators shall be final, and judgment may be entered upon it in accordance with applicable law in any court having jurisdiction thereof.

§ 15.4.3 The foregoing agreement to arbitrate and other agreements to arbitrate with an additional person or entity duly consented to by parties to the Agreement shall be specifically enforceable under applicable law in any court having jurisdiction thereof.

#### § 15.4.4 CONSOLIDATION OR JOINDER

§ 15.4.4.1 Either party, at its sole discretion, may consolidate an arbitration conducted under this Agreement with any other arbitration to which it is a party provided that (1) the arbitration agreement governing the other arbitration permits consolidation; (2) the arbitrations to be consolidated substantially involve common questions of law or fact; and (3) the arbitrations employ materially similar procedural rules and methods for selecting arbitrator(s).

§ 15.4.4.2 Either party, at its sole discretion, may include by joinder persons or entities substantially involved in a common question of law or fact whose presence is required if complete relief is to be accorded in arbitration, provided that the party sought to be joined consents in writing to such joinder. Consent to arbitration involving an additional person or entity shall not constitute consent to arbitration of a Claim not described in the written consent.

§ 15.4.4.3 The Owner and Vendor grant to any person or entity made a party to an arbitration conducted under this Section 15.4, whether by joinder or consolidation, the same rights of joinder and consolidation as the Owner and Vendor under this Agreement.

THIS PAGE INTENTIONALLY LEFT BLANK

**PART 1 – GENERAL****1.1 SAFETY POLICY AND PROGRAM****A. RESPONSIBILITIES OF THE PRIME CONTRACTORS**

1. The Prime Contractor shall use its best care, skill and diligence in supervising and directing the Work of the Prime Contract. The Prime Contractor shall have total responsibility and control over the performance of the Prime Contract Work, including sole responsibility for construction means, methods, techniques, sequences, and procedures for coordinating and completing the various portions of the Prime Contract Work.
2. Prevention of accidents at the site is the responsibility of the Prime Contractor, its employees, subcontractors, and suppliers, and all other Prime Contractors, persons, and entities at the site. The Prime Contractor shall establish its own safety program implementing safety measures, policies, and standards conforming to those required or recommended by governmental and quasi-governmental authorities having jurisdiction. The Construction Manager is not responsible for identifying unsafe practices, and the Construction Manager's failure to stop the Prime Contractor's unsafe practices shall not relieve the Prime Contractor of the responsibility therefore. The Prime Contractor shall indemnify the Construction Manager and the Owner for fines and penalties imposed on the Construction Manager or Owner as a result of safety violations.
3. To the fullest extent permitted by law, the Prime Contractor will defend, indemnify and save harmless the Owner, the Construction Manager, the Architect and/or Engineers (the "parties"), and their agents, representatives, directors, officers and employees against any and all liability loss, damage, detriment, suit, claim, demand, cost, charge, attorneys' fees and expenses of whatever kind or nature which they may directly or indirectly incur, suffer or be required to pay by reason, or in consequence, of the carrying out of any of the provisions or requirements of this Contract where such loss or expense is incurred directly or indirectly by these parties, their employees, Prime Contractors or agents as a result of the work and operations. Prime Contractor has no liability or obligation to indemnify or hold harmless the Owner, the Construction Manager, the Architect and/or Engineers against liability arising out of bodily injury to persons or damages to property contributed to, caused by or resulting from the negligence of these parties, their agents, representatives, directors, officers and employees. If a claim or action is made or brought against them for which the Prime Contractor may be responsible hereunder, in whole or in part, then he shall be notified and shall be required to handle or pay for the handling of the portion of the claim for which he is responsible as a result of this section.

4. The Prime Contractor's Insurance required shall be considered primary and non-contributing insurance. The types and coverage's shall be written for not less than the limits of liability required. The Owner, the Construction Manager, the Architect and/or Engineers shall be named as additional insured with respects to coverage's.
- B. General Safety: All CONTRACTORS are responsible to maintain a safe job site for all workers, building occupants, and public, and shall comply with all requirements of OSHA, the Connecticut Labor Laws, and all Federal and Local regulatory agencies.
  - C. Safety Manuals: All CONTRACTOR'S shall prepare, submit and actively implement a proper project specific Safety Program throughout the duration of the project. Each CONTRACTOR shall provide all necessary safety railings, signs, bracing, special lighting, ventilation, etc. for their own work at all individual locations as may be applicable, (unless otherwise specified). A copy of the safety manual shall be maintained on site by the contractor as a reference document for their employees.
  - D. Personal Protection: All CONTRACTOR'S personnel shall wear Hardhats and Safety Glasses on site for the entire project duration.
  - E. Protection: All CONTRACTORS will assume full responsibility for the protection and safekeeping of their products whether installed or stored on the site and shall cooperate with the Construction Manager to ensure security for the Owner's property. All CONTRACTOR'S are to provide protection and cleaning of their items included within their scope of work until Owner's acceptance. If protection has not been provided or maintained the material will be refinished repaired or replaced at the discretion of the Construction Manager at no cost to the Owner.
  - F. Access: All CONTRACTOR'S are responsible for providing safe access in order to perform their own work: i.e., OSHA designated ladders, scaffolding, lifts, and removal of snow and ice as it pertains to CONTRACTOR'S scope of work.
  - G. Access: All CONTRACTOR'S will plan, provide and maintain their own access (unless otherwise specified), ramping, and egress as required into, around and out of the site, staging of trailer(s), materials, machinery, and equipment in agreement with the Construction Manager and OSHA regulations. Maintain free and safe access on the job site for other related project personnel. Maintain safe public pedestrian and vehicular traffic outside the Contractor work area. Provide alternate routes around closed or obstructed traffic ways if required by authorities having jurisdiction. Any operation interfering with pedestrian or vehicular traffic must be regulated by flagmen as necessary. Trucking, delivery and storage operations should be coordinated with Construction Manager and other Contractors.
  - H. Public Safety: All CONTRACTORS shall identify to the Construction Manager and Owner any potential hazards to building occupants, the general public, and the environment resulting from the project, and shall provide measures to maintain a project site which is safe to all persons.
  - I. Temporary Protection/Barricades: Temporary protection/barricades to be provided and maintained in areas as necessary by the contractor performing the work.

- J. Public Safety: All CONTRACTOR'S will keep driveways and entrances serving the premises clear and available to the Owner, the Owner's employees, the public and emergency vehicles at all time. Do not use these areas for parking or storage of materials.
- K. Ventilation: Each Contractor shall be responsible for ventilation in all areas to exhaust toxic, noxious or otherwise hazardous fumes, gases, or dusts, etc., from welding, cadwelding, painting, and grinding, sawing, sweeping, hazardous activity. Operations shall be kept to the absolute minimum and shall be vented directly to the outside by the Contractor performing the work. If Contractor cannot keep the fore mentioned to the absolute minimum or vent directly outside, and the fore mentioned activity prohibits other Contractors from performing work, said Contractor creating fumes, dust, etc. as mentioned above must make provisions to complete work creating problem at a time including, but not limited to, nights and weekends, so as to allow other Contractors to proceed with work.
- L. Noise Control: All CONTRACTOR'S will take all necessary measures to reduce the amount of noise generated by construction activities. Control sources of noise such as engines and exhaust systems by using new equipment and exhaust systems, by using new equipment or properly maintained used equipment meeting new product noise emission standards. Control locations of noise by placing noise-generating equipment as far away from sensitive areas as possible. Perform work generating noise at times when people would be least affected, i.e. normal daytime business hours. Provide public notification of construction operations and methods to handle complaints.
- M. Noise Control: AM/FM radios, CD players (walkman, etc.) or headsets will NOT be allowed on job site work areas at any time.
- N. First Aid: All CONTRACTOR'S will be responsible to provide their own First Aid Kit.
- O. Fire Watch: All CONTRACTOR'S shall provide their own fire watch and fire extinguishers while burning, cutting or welding. CONTRACTORS are responsible for obtaining hot work permits as required by the Town of Glastonbury Fire Marshal.
- P. Cranes: Each Contractor shall define and enclose an area around any crane, and/or hoisting devise posing overhead hazard, in its use sufficient to insure the protection of unauthorized personnel. Where it is impractical to divert unauthorized personnel or vehicles for the area, each contractor shall provide delineators and flagmen as approved by the Construction Manager. Appropriate signage shall be provided by the Contractor performing the work.
- Q. Hazardous Materials: If hazardous materials are discovered the CONTRACTOR is required to stop work in area where hazardous materials are discovered and is to immediately notify the Construction Manager.
- R. Weekly Tool Talk Box Meetings: Each Contractor shall organize and enforce a comprehensive Tool Box meeting system which educates all workers about the

various hazards of the construction job site. Contractors shall maintain detailed records and sign-in sheets of each meeting and provide a copy to the Construction Manager for information.

- S. Hazard Communication: Each Contractor shall maintain a hazard communication program on the job site that complies with all regulatory agencies. This program shall include two complete Hazcom manuals; one copy shall be provided to the Construction Manager and one copy shall be retained by the Contractor. The Contractor shall update both copies to keep them current at all times.
- T. Enforcement: Each Contractor shall enforce compliance with all safety regulations and contract requirements, with their own employees and the employees of their subcontractors. The Construction Manager has the right, but not the obligation, to stop any construction activity that is considered to be unsafe, and notify the Contractor. The Contractor shall address the unsafe condition as per the Contractor's Safety Manual.
- U. Emergencies: Prior to the start of work each contractor shall provide to the Construction Manager a list of key personnel and their phone numbers as may be required in an emergency situation.
- V. Emergencies: A project emergency response plan will be implemented at the start of construction. Each CONTRACTOR is responsible for participating in the plan.
- W. Incident Reports: In the event of an accident, injury and/or abnormal incident the Contractors shall notify the Construction Manager immediately and within 24 hours submit an accident report to the Construction Manager's Project Manager.
- X. Violations Resulting in Removal from the Project Job Site: Insubordination, unsafe work practices, abusive language, destruction of property, use of drugs or alcohol, possession of firearms and solicitation will no be tolerated and are grounds for removal from the project job site. The following conditions will result in immediate removal from the project site:
  - 1. Any employee, supervisor or manager that exposes themselves, the public, or other employees to imminent loss of life.
  - 2. Any employee, supervisor or manager that openly exhibits disregard or defiance for project safety.
  - 3. Any employee whom knowingly falsifies any investigation document or testimony.
  - 4. Possession, consumption or under the influence of alcohol or drugs on the job site.
- Y. SITE ACCESS/EMPLOYEE SIGN-IN
  - 1. Each contractor shall assign a supervisor, whom is a full time site employee, to complete and submit to the Construction Manager, a daily sign-in log. The supervisor shall be responsible for verifying the information on the log and assuring each employee has met the requirements for accessing the site. A

designated substitution shall be assigned shall the supervisor not be present. Each contractor's designated supervisor shall review, sign and submit the daily sign-in sheet to the Construction Manager on or before 8:00 am each day.

2. Access to the job site and Identification (ID) Badges: Construction Manager is requiring monitored access of every individual entering and exiting the facility building. Each contractor is required to wear their Identification Badge anytime they are working on the project site. Identification badges shall be obtained through the Construction Manager. Suppliers delivering materials onsite will be required to sign in upon entering the job site, obtain a temporary badge, and sign out upon exiting the facility surrendering the badge upon exiting.

## Z. STANDARD POLICIES

1. On-Site Behavior: Each Contractor is responsible for the enforcement among his employees for maintaining harmony on the project site. Each contractor shall inform and enforce to employees, that any behavior deemed unacceptable to the Construction Manager or Owner will be cause for immediate dismissal.
2. Radios, Music Players, Noisemakers: Radios, music-players and any type of noise-maker not required for installation of work, are not permitted on the project job site. The DB will not allow music players of any type. Failure to comply may result in confiscation or damage to items with all recovery costs to be the responsibility of the item owner.
3. Smoking/Tobacco Policy: Chewing Tobacco, Smoking and open fires are not permitted on the project site. All buildings and vehicles, regardless of location on the project site are to be entirely smoke-free. Smoking and chewing tobacco will be permitted only in the contractor designated smoking area as appointed by the Construction Manager.
4. Alcohol/Drugs: Possession, sale, consumption or being under the influence of alcohol and/or use of unlawful controlled substances (drugs) is prohibited in and on the owner or controlled property.
5. Weapons: Weapons of any type (firearms, bb or pellet guns, double-edged knives, bows, arrows, stun guns, paint ball guns and the like) are prohibited in and on the property.
6. Violence: Violence including but not limited to threats, intimidation, assault, intolerance, hate crimes and sexual harassment or assault is prohibited on the property.
7. Theft or Damage to Property: Theft and/or damage to property must be reported and handled as appropriate.
8. Sanitary Facilities: All employees are to utilize the temporary sanitary facilities located within the project work zone as provided by the Sitework Contractor.
9. Non-Compliance: Failure to comply with the standard polices as set forth in project documents and/or as listed above will be considered grounds for removal from the project.



PART 2 – MATERIALS

Not Used

PART 3 – EXECUTION

Not Used

END OF SECTION

THIS PAGE INTENTIONALLY LEFT BLANK

**INTRODUCED:** JUNE 12, 2007  
**PUBLIC HEARING:** JUNE 26, 2007  
**ADOPTED:** JUNE 26, 2007  
**PUBLISHED:** JULY 5, 2007  
**EFFECTIVE DATE:** JULY 16, 2007

#314

### **DIVISION 3. CODE OF ETHICS**

#### **Sec. 2-56. Declaration of policy and purpose**

The proper operation of government of the Town of Glastonbury requires that public officials and public employees be impartial, responsible to the people and not have interests that would be incompatible with the proper discharge of their official responsibilities or tend to impair their independence of judgment or action in the performance of their official duties and responsibilities; that governmental decisions and policies be made in the proper channels of governmental structure and free from undue influence; that governmental office and employment not be improperly used for personal gain; that government officials and employees strive to avoid even the appearance of impropriety; and that the public has confidence in the integrity of its government. The purpose of this code of ethics is to maintain and enhance a tradition of responsible and effective public service by setting forth standards of ethical conduct to guide officials and employees in the conduct of their public responsibilities. This code of ethics also sets forth ethical standards for consultants who are in a position to influence the decisions of town agencies, officials or employees, and establishes an ethics commission to determine the applicability of the code to specific situations and to issue advisory opinions and memoranda of decision with respect to the conduct of officials, employees and consultants under the code.

This code of ethics is established pursuant to Section 1101 of the Charter of the Town of Glastonbury and Connecticut General Statutes Subsection 7-148h.  
(Ord. No. 296, 7-8-03)

#### **Sec. 2-57. Definitions.**

For the purposes of this code of ethics, the following terms shall have the indicated meanings:

*Agency* is any board, commission, authority and committee of the town, including the town council and board of education.

*Agent* is the town manager, superintendent of schools, or the executive, administrator, or legislative official empowered to execute documents on behalf of the town, board of education, or other agency.

*Appropriate Authority* is the executive, administrator, official, board, commission or authority to whom or to which disclosure is directed to be made by section 2-65 of this division, or who has the administrative or operating authority to approve, disapprove, or otherwise direct government action.

*Beneficial Interest* means any non-financial interest or special treatment that is not common to other citizens of the town. An individual's "beneficial interests" shall include the "beneficial interests" of all members of his/her family.

*Code* is this code of ethics.

*Complaint* means an allegation concerning a violation of the Code following a finding of probable cause. Prior to a finding of probable cause, the commission may refer to any allegation concerning a violation of the Code as an "inquiry" or other appropriate term and require that any complaint be initiated by means of an inquiry.

*Confidential Information* means information, however transmitted, that is obtained by an official, employee or consultant by reason of his/ her public position and is of such nature that, at the time of transmission, it is not a matter of public record or public knowledge.

*Consultant* is any independent contractor or professional person or firm that is by virtue of an award of a public bid or contract as defined in Glastonbury Code of Ordinances sections 2-262 and 2-263, engaged by and receives compensation from the town or board of education for the purpose of providing professional, scientific, technical or other specialized opinion and is in a position to influence any decision of an agency, official or employee.

*Employee* is any person receiving a salary, wages or stipend from the town or board of education for services rendered, whether full time or part-time.

*Family* means the spouse, domestic partner, fiancé, fiancée, parents, grandparents, great-grandparents, lineal descendants, stepchildren, siblings, lineal descendants of siblings and stepsiblings of an official, employee or consultant, or of his/her spouse or domestic partner.

*Official* is any person holding elective or appointive office in the government of the town and shall include, but not be limited to, the town council, board of education, board of finance, town plan & zoning commission, town attorney, or any other agency.

*Significant Financial Interest* means any interest that: (1) has a monetary value of one hundred dollars (\$100.00) or more or generates a financial gain or loss of one hundred dollars (\$100.00) or more in a calendar year; and (2) is not common to the other citizens of the town. An individual's "significant financial interests" shall include the financial interests of all members of his/her family, but shall not include any duly authorized compensation from the town.

*Town* is the Town of Glastonbury.

*Valuable Gift* is a gift of more than fifty dollars (\$50.00) in value. A valuable gift includes, but is not limited to, entertainment, food, beverage, travel, and lodging to the extent that the gift value exceeds fifty dollars (\$50.00) for any one (1) occasion, and one hundred dollars (\$100.00) total in any one (1) year from the same person, as well as loans that are not commercially reasonable.

Valuable gifts do not include:

- (1) A political contribution that is otherwise reported in accordance with the law.

- (2) A loan made on terms that are commercially reasonable and not more favorable than loans made in the ordinary course of business.
- (3) Any gift regardless of value received from: (i) any family member who resides in the same household as the recipient of the gift, or (ii) another family member unless the other family member who makes the gift is interested, directly or indirectly, in a business transaction or pending matter that is within the purview or responsibilities of (A) the recipient of the gift, or (B) another family member residing in the same household as the recipient of the gift.
- (4) Certificates, plaques or other ceremonial awards costing less than fifty dollars (\$50.00).
- (5) Honorary degrees.
- (6) A meal, ticket, beverages, and lodging costing less than or equal to fifty dollars (\$50.00), but only if the total of all such gifts from a particular person does not exceed one hundred dollars (\$100.00) in any one (1) year.

(Ord. No. 296, 7-8-03)

**Sec. 2-58. Ethics commission.**

(a) *Establishment.* The town council shall appoint an ethics commission consisting of five (5) regular members and two (2) alternate members. No more than two (2) of the regular members may be affiliated with any one (1) political party and the alternate members may not both be affiliated with any political party. The members of the commission shall serve four-year terms, except that at the first appointment by the town council three (3) regular members and one alternate shall be appointed for two-year terms, with the remaining regular members and alternate appointed for four-year terms. Thereafter, the town council shall appoint commission members in the manner provided in the Town Charter, provided that such members are qualified under subsection (c) below and that at all times at least one (1) regular member shall not be affiliated with any political party. Members of the ethics commission shall be appointed by a minimum of seven (7) affirmative votes of the town council.

(b) *Organization and procedure.* The commission shall elect a chairman and vice chairman/secretary who shall serve for two-year terms. The commission shall establish its own rules and procedures, not inconsistent with the Code which shall be available at the office of the town clerk. The first rules and procedures shall be established within six (6) months of the date on which the town council initially appoints members of the commission. The need to maintain confidentiality in order to protect the privacy of officials, employees and consultants shall be recognized by the commission when establishing its rules and procedures. The commission shall keep records of its meetings and shall hold meetings at the call of the chairman and at such other times as may be provided by rules and procedures adopted by the commission. The procedures of the commission in effect on [insert date ordinance revisions are adopted] are hereby incorporated into the Code as provided in section 2-69, and said procedures may be amended from time to time by submission of proposed amendments to the town council by the commission and adoption thereof by the town council.

(c) *Qualifications.* Each member and each alternate member shall be an elector of the town and shall not be compensated for service on the commission.

No member or alternate member shall:

- (1) Hold or campaign for any town or state office.
- (2) Hold, or have held for a period of two (2) years prior to being appointed as a member or alternate member of the commission, any town, state or federal office including the town committee of a local political party or be, or have been, a candidate for any town, state or federal office for a period of two (2) years prior to being appointed as a member or alternate member of the commission.
- (3) Hold office in any political action committee, or be an officer or member of a national committee of a political party, state central or town committee, or be employed by any such committee for compensation.
- (4) Serve as a member of any other agency.
- (5) Have been found in violation of any state, municipal or professional code of ethics.
- (6) Be employed by the town, or have been employed by the town during the period two (2) years prior to the date of appointment as a member or alternate member of the commission.
- (7) Publicly support or oppose, or have publicly supported or opposed during the period two (2) years prior to the date of appointment as a member or alternate member of the commission, any candidate for town office. "Publicly supported or opposed" shall include, but not be limited to, acting as a campaign worker, giving a speech at a political event, or publicly endorsing or opposing a candidate.

(d) *Powers and duties.*

- (1) The commission shall have the power to render advisory opinions with respect to the requirements of the code upon the request of any person subject to the provisions of the code or upon the commission's own initiative. The commission may also issue guidelines and a plain language handbook explaining the various provisions of the code. Such opinions and guidelines, until amended or revoked, shall be binding on the commission and reliance upon them in good faith shall be an absolute defense in any action brought under the provisions of this division or under Section 1101 of the Town Charter. Any request or opinion, the disclosure of which invades the personal privacy of any individual, as that term is used in Connecticut General Statutes §1-210(b) and interpreted by the Connecticut Freedom of Information Commission and the courts, shall be kept confidential by the commission in a personnel or similar file and shall not be subject to any public inspection or disclosure. The commission shall make available to the public any of its advisory opinions

that do not invade a personal privacy of an individual and may take other appropriate steps in an effort to increase public awareness of the code.

- (2) The commission's procedures shall specify how the public may initiate complaints alleging a violation of the code. All complaints shall be initiated on a form prescribed by the commission and signed under penalty of false statement. The commission itself, by majority vote, may also initiate a complaint. The commission shall have the power to hold hearings concerning the application of the code and alleged violations and may administer oaths and compel the attendance of witnesses by subpoena to the extent permitted by state law. As required by §7-148h(a) of the Connecticut General Statutes, the provisions of §1-82a (a) through (e) of the Connecticut General Statutes shall apply to all investigations and hearings held under this ordinance. If no less than four (4) members of the commission determine that there is probable cause it shall continue the investigation and hold such further hearings as may be necessary.
- (3) If the commission determines that the respondent has violated the provisions of this code, the commission shall file a memorandum of decision within ten (10) days following its finding of a violation with the town council and give notice of such memorandum to the respondent and the complainant. The commission shall also file its memorandum of decision with the town manager within ten (10) days after its finding of a violation if the respondent is an employee, consultant, or official appointed or under the jurisdiction of the town manager; with the superintendent of schools and the board of education if the respondent is an employee, consultant, or official appointed or under the jurisdiction of the superintendent of schools or board of education. The commission shall make no finding that there is a violation of any provision of the code except upon the concurring vote of at least four (4) of its members.
- (4) If the commission determines that the respondent has not violated the provisions of this code, the commission shall notify the respondent and complainant within ten (10) days of such finding.
- (5) Nothing herein shall limit the authority of the town council, town manager or the board of education and superintendent of schools under the Town Charter or under any ordinance, statute or any other law, and the actions hereunder shall be supplemental to any authority the town council, town manager or board of education and superintendent of schools has under any ordinance, statute or any other law. Any discussion by the town council, board of education or contracting agency of an individual affected by a commission memorandum of decision shall be in executive session unless the affected individual requests that such discussion be held in open session.
- (6) Nothing herein shall be construed to require disclosure of documents that are otherwise exempt under the Freedom of Information Act.

- (7) No complaint may be brought after three (3) years from the date the action giving rise to the complaint occurred.

(Ord. No. 296, 7-8-03)

**Sec. 2-59. Consultants.**

The code shall be incorporated after the effective date, by reference into all contracts entered into by the town and board of education with a consultant.

Persons or firms who are engaged by and receive compensation from other governmental entities, such as the state or federal government, and who are in a position to influence any decision of an agency, official or employee shall be guided by the code, and the commission, upon complaint or its own motion, may make recommendations to the entity employing such persons.

(Ord. No. 296, 7-8-03)

**Sec. 2-60. Confidential information.**

Except as otherwise required by law, no official, employee or consultant shall disclose, without proper authorization, confidential information, nor shall such person use such information to advance his/her significant financial interest or beneficial interest or otherwise use confidential information in a manner inconsistent with the proper performance of his/her public duties. This section shall not be interpreted to restrict the disclosure of information that is properly available to the public.

(Ord. No. 296, 7-8-03)

**Sec. 2-61. Use of influence.**

No individual shall use his/her position as an official, employee or consultant to seek, demand, or obtain a significant financial interest or a beneficial interest in his/her favor or the favor of any member of his/her family.

(Ord. No. 296, 7-8-03)

**Sec. 2-62. Gifts and favors.**

(a) No official, employee or consultant or any member of his/her family who resides in the same household, nor any agency, employee organization or group of employees shall solicit or accept any valuable gift, whether in the form of a service, a loan at a less than a commercially available rate, a material thing or a promise, from any person or entity who or which is interested directly or indirectly in any business transaction or pending matter that is within the purview of such official, employee, consultant, agency, employee organization or group of employees. No official, employee or consultant shall accept, or knowingly seek or cause to be given to any member of his/her family, any valuable favor, treatment, consideration or advantage beyond that which is generally available to citizens of the town from any person who, to the knowledge of the official, employee or consultant, is interested directly or indirectly in any business transaction or pending matter that is within the responsibilities of the official, employee or consultant. For purposes of this section, a pending matter includes, but is not limited to, any application to an agency, a bid for work to be performed, an application for employment, and any bid for the furnishing of supplies, equipment or services.



(b) This section shall not apply to any political contribution that is reported as required by law.  
(Ord. No. 296, 7-8-03)

**Sec. 2-63. Equal treatment.**

Without proper authorization, no official, employee or consultant shall accept, seek, grant or cause to be granted any special consideration, treatment or advantage to such individual or his/her family by virtue of his/her position.  
(Ord. No. 296, 7-8-03)

**Sec. 2-64. Conflict of interest.**

An official, employee or consultant has a conflict of interest when that individual engages in or participates in any contract, transaction, decision, employment, or rendering of service that is incompatible with the proper discharge of that individual's official responsibilities in the public interest or would tend to impair his/her independent judgment or action in the performance of official responsibilities.

A significant financial interest or beneficial interest presents a conflict of interest that is incompatible with the proper discharge of official responsibilities in the public interest if the official, employee or consultant has reason to believe or expect that he/she will obtain, secure or advance such interest by reason of his/her actions in performance or non-performance of his/her official responsibilities.

An official, employee or consultant does not have a significant financial interest or beneficial interest that is incompatible with the proper discharge of his/her official responsibilities in the public interest if the interest accrues to such individual as a member of a profession, occupation, or group to no greater extent than it accrues to any other member of the profession, occupation, or group with which he/she is affiliated as set forth in Connecticut General Statutes Section 7-148h(b).  
(Ord. No. 296, 7-8-03)

**Sec. 2-65. Disclosure and disqualification.**

(a) Any official, employee or consultant who has a conflict of interest, significant financial interest or beneficial interest, direct or indirect, in any contract, transaction or decision within the purview of his/her official responsibilities shall disclose that conflict of interest in accordance with Section 2-65(c)(1)-(6). Such disclosure shall disqualify the official, employee or consultant from participation in the matter, transaction, or decision.

(b) No official, employee or consultant shall appear on behalf of any private person or party before any agency in connection with any cause, proceeding, application or other matter in which he/ she has a significant financial interest or beneficial interest without first disclosing such interest to the agency, which shall record such disclosure in the record of the agency's proceeding.

(c) If there is an uncertainty whether an official, employee or consultant has a conflict of interest, significant financial interest or beneficial interest that could disqualify that individual

from participation in a matter, such individual shall disclose such possible conflict of interest to the following:

- (1) For an official who is a member of an elective or appointive board, commission, committee, or authority to the particular agency of which such official is a member.
- (2) For town employees and officials appointed by the town manager to town manager.
- (3) For board of education employees to the superintendent of schools.
- (4) The town manager to town council.
- (5) The superintendent of schools to the board of education.
- (6) For a consultant to the agent executing contract on behalf of the town or board of education.

(d) The appropriate authority to which the disclosure is made shall make an appropriate record of such disclosure and shall recommend to the official, employee or consultant making the report whether such official, employee or consultant should abstain from participating in the transaction or decision to which the possible conflict of interest relates and whatever other appropriate action should be taken.

(e) Any such questions concerning a possible conflict of interest may be referred to the commission for an advisory opinion.

(Ord. No. 296, 7-8-03)

#### **Sec. 2-66. Incompatible employment and activities.**

(a) No official or employee shall engage in or accept private employment or render services when the employment or services: (1) are incompatible with the proper discharge of the official duties of the official or employee; or (2) would tend to impair independence of judgment or action by the official or employee in the performance of that individual's official duty. No consultant shall engage in employment or render services for interests other than the town when such employment or services: (1) are incompatible with the proper discharge of his/her consulting duties on behalf of the town; or (2) would tend to impair the independence of the consultant's judgment or action on the matter for which the consultant has been engaged by the town.

(b) No former official, employee or consultant shall appear on behalf of any person or other entity before any agency with which he/she previously was employed or affiliated for a period of one (1) year after the termination of his/her public service or employment; provided, however, that such an individual may be permitted to make such an appearance upon receipt of a favorable commission opinion following the commission's review of the individual's written application and relevant facts.

(c) No former official, employee or consultant shall appear on behalf of any person or other entity before any agency in regard to a matter in which that individual previously

participated in the course of his/her official responsibilities for a period of one (1) year after the termination of his/her public service or employment; provided, however, that such an individual may make such an appearance upon receipt of a favorable commission opinion following the commission's review of the individual's written application and relevant facts.

(d) Subsections (a), (b) and (c) of this section shall not prohibit any current or former official, employee or consultant from appearing before any agency on his/her own behalf or on behalf of immediate family members. To avoid the appearance of impropriety, officials are strongly discouraged from recusing themselves and appearing before the agency on which they are a member or officer unless extenuating circumstances exist. When in doubt, an official should secure a favorable opinion from the commission prior to appearing before any agency on which the official is a member or officer.

(e) Nothing in the code shall be interpreted to authorize conduct restricted or prohibited by any provision of the Connecticut General Statutes including, but not limited to, Section 8-11, 8-21, and 22a-42(c) that restrict conduct of members of municipal zoning and planning authorities and members of wetlands and water courses boards or commissions.

(f) To avoid even the appearance of impropriety or creation of a situation that would be contrary to the declared policy and purpose of the code, an official, not otherwise restrained by the code, shall exercise care when appearing before other agencies and shall disclose whether he/she is appearing in his/her official capacity or as a private citizen.  
(Ord. No. 296, 7-8-03)

#### **Sec. 2-67. Penalty for violation.**

In the event of a failure to comply with section 2-65 or any of the provisions of the Code or of Town Charter Section 1101, such failure shall be considered grounds for censure, reprimand, suspension, demotion, removal, or dismissal of officials, employees and consultants as applicable. The remedies and procedures specified in applicable statutory and Charter provisions, personnel rules, contract grievance rules, or other work rules, policies and procedures, shall be followed in the enforcement of this section.  
(Ord. No. 296, 7-8-03)

#### **Sec. 2-68. Acknowledgment form.**

(a) The town clerk shall cause a copy of the Code and Town Charter Section 1101 to be distributed to every official not later than sixty (60) days after the effective date of this section. Each official who is appointed or elected after the effective date of this division shall be furnished a copy of the Code and Town Charter Section 1101 before beginning his/her duties as an official. A signed receipt for all copies shall be returned to the town clerk and retained on file.

(b) Each consultant shall sign and file with the town clerk an acknowledgment form indicating his/her awareness of the provisions of this code, and Section 1101 of the Town Charter on or before being retained by the town, board of education, or other agency.

(c) The town manager and superintendent of schools shall develop a protocol for periodic training of employees concerning this division and Town Charter Section 1101. The commission shall develop a protocol for periodic training of officials.

(d) The town council shall approve a procedure for monitoring compliance with this section and approve the training protocols specified in subsection (c).

(e) The commission shall develop an acknowledgement form for approval by the town council.

(Ord. No. 296, 7-8-03)

### **Sec. 2-69. Ethics Commission rules of procedure.**

(a) These procedures shall be used by the ethics commission established in Section 2-58 hereof, and are designed to guide public officials, officers, employees, consultants and citizens of the process to be followed if they seek advice or question the conduct of those in or affiliated with Town government. Subsection (b), Advisory Opinions, describes a process for Town officers, officials, employees or consultants, and other parties doing business with the Town who are seeking advice about their own conduct or the conduct of a Town office or function. Subsection (c), Inquiries, describes a process for resolving questions about specific conduct of a current Town officer, official, employee or consultant, or about a Town office or function. Subsection (d), Complaints, describes a formal, public procedure for considering matters that cannot be resolved through the processes outlined in subsection (b) for Inquiries. Subsection (e), Other Communications; Miscellaneous, describes the process to be followed by anyone wishing to bring something to the attention of the commission, without requesting an Advisory Opinion or filing an Inquiry.

#### **(b) Advisory Opinions**

##### **(1) Initiation**

(a) Any current, former or prospective Town of Glastonbury employee, officer, official, consultant, or other party doing business with the Town may request an Advisory Opinion from the commission on whether conduct by that person or entity would violate the Code. Any current Town official also may request an Advisory Opinion concerning the activities of any department over which he or she has jurisdiction or board or commission on which he or she serves.

(b) Individuals initiating a request for an Advisory Opinion must do so by completing a form available through the Glastonbury Town Clerk's Office or through the Town's web site, [www.glastonbury-ct.gov](http://www.glastonbury-ct.gov). The form must contain a statement setting forth the advice requested, and the relevant facts known to the individual making the request so that the commission can reasonably be expected to understand the nature of the request. The individual making the request must sign it.

(c) Requests must be addressed to the chair of the commission, c/o the Glastonbury Town Clerk, 2155 Main Street, Town Hall, Glastonbury, Connecticut who will forward the request promptly to the chair of the commission.

(d) The Town Clerk will maintain each original request for an Advisory Opinion in a confidential, indexed file until the request has been screened by the commission chair or vice chair to determine that it does not contain any allegation of a Code violation which would subject it to confidentiality requirements. Upon finding that no such allegation exists, the file will be made available for public inspection. The

commission chair or vice chair will specifically identify to the Town Clerk in writing which files should and should not be made available for public inspection.

(e) The date the request is received by the chair of the commission will mark the official date of receipt for purposes of deadlines for decisions.

## (2) Proceedings

(a) The chair will present the request to the commission at its next regular meeting for which no agenda has been filed yet with the Town Clerk.

(b) The commission will meet to review the request. At that time, it may decide to: (1) seek additional information, (2) create a subcommittee of at least two commission members to make a recommendation for consideration by the full commission, (3) hold an informal hearing to receive comments from the individual who requested the Advisory Opinion and/or from the public, (4) investigate the relevant facts and issues in order to render the Advisory Opinion, and/or treat the matter as an Inquiry under subsection (c) hereof.

## (3) Decisions

(a) Advisory Opinions will be made by a majority of commission members.

(b) The commission will issue an Advisory Opinion as expeditiously as possible but in any event within 90 days from the day it first considers the request. The commission may extend the time for decision for up to an additional 30 days.

(c) All Advisory Opinions must be in writing and communicated to the individual making the request.

(d) The commission may decline to render an Advisory Opinion if (1) the subject matter is not covered by the Code, (2) the known facts are incomplete or incorrect and the omissions or misstatements are material to the Advisory Opinion requested, or (3) other reasonable grounds exist for not taking action. If the commission decides to so act, it shall state its reasons.

## (4) Confidentiality

(a) Requests for Advisory Opinions will be reviewed in open session unless, upon review by the commission chair or vice chair, it is determined that the matter would be more appropriately treated as an Inquiry under subsection (c) hereof and pursuant to Section 1-82a of the Connecticut General Statutes.

(b) Requests for Advisory Opinions that are treated as Inquiries under subsection (c) hereof will be reviewed in closed session, except upon the request of the person who is the subject of the Inquiry.

(c) Advisory Opinions for matters not treated as Inquiries under subsection (c) hereof will be available for public inspection through the Town Clerk's Office.

## (c) Inquiries

### (1) Initiation

(a) Any member of the public may submit an Inquiry asking whether a current officer, official, consultant or employee has failed to comply with the Code or asking about the appropriateness of conduct of a particular government office or function.

(b) The commission may itself initiate an Inquiry regarding a possible violation of the Code.

(c) Individuals initiating an Inquiry must do so by completing a form, available through the Glastonbury Town Clerk's office or through the Town's web site at [www.glastonbury-ct.gov](http://www.glastonbury-ct.gov). The initiating individual must sign the form under penalty of false statement. The form must contain a description of the relevant facts in sufficient detail so that the commission and any person who is the subject of the Inquiry can reasonably be expected to understand the nature of the allegations.

(d) Inquiries must be addressed to the chair of the commission, c/o the Glastonbury Town Clerk, 2155 Main Street, Town Hall, Glastonbury, Connecticut who will forward the Inquiry promptly to the chair of the commission.

(e) The Town Clerk will maintain all original Inquiries in a confidential, indexed file.

(f) The date an Inquiry is received by the chair of the commission will mark the official date of receipt for purposes of deadlines for decisions.

### (2) Notice

(a) Within 5 business days of the chair's receipt of the Inquiry or initiation of an independent Inquiry, the commission will notify the individual who is the subject matter of the Inquiry by registered or certified mail and will provide the person with a copy of the completed form, the Code, and this Section 2-69. The commission also will confirm in writing to the person who initiates an Inquiry that it was received by the commission.

(b) The person who is the subject of any Inquiry (Subject) may file a written response with the chair of the commission within 10 business days after receiving the notice.

### (3) Proceedings

(a) The chair will present the Inquiry and any response received from the Subject to the commission at its next regular meeting held after receipt of the Inquiry, the mailing of notice to the Subject, and the passage of at least 10 additional business days. However, if the agenda for such meeting has been posted already with the Town Clerk, then the chair will present the Inquiry and any response to the commission at

its next following regular meeting. The commission also may consider the Inquiry at a special meeting called for such purpose after the passage of such 10-day period.

(b) The commission will meet one or more times in closed session from which the public is excluded to review the Inquiry and to determine whether or not there exists probable cause that the Code has been violated. In those sessions, it may decide to: (1) seek additional information, (2) create a subcommittee of at least two commission members to make a recommendation for consideration by the full commission, (3) proceed to investigate the relevant facts and issues in order to render a decision, (4) decline to review the matter further, pursuant to subsection (c)(3)(d) hereof, (5) endeavor to resolve the matter by convening a confidential meeting that includes the individual who is the subject of the Inquiry and others relevant to the issue, (6) make a finding of probable cause and treat the matter as a Complaint under subsection (d) hereof, and/or (7) make a finding of no probable cause. If the commission proceeds under steps (1), (2), (3), or (5) above, it will establish a schedule of meetings for consideration of the Inquiry, subject to the provisions of subsection (c)(4)(a) hereof.

(c) A finding of probable cause means that based on a review of the available information the commission determines that reasonable grounds exist to believe that a violation of the Code occurred.

(d) The commission may decline to continue to review a matter on any of these grounds:

- i. The alleged facts do not evidence the existence of probable cause of a violation of the Code.
- ii. The person who is the subject of the Inquiry is a minor.
- iii. The person who is the subject of the Inquiry is no longer an official, officer or employee of the Town or a consultant for the Town.
- iv. The matter occurred more than 3 years earlier or before the enactment of the Code by the Town of Glastonbury.
- v. The matter is judged to be frivolous, groundless, or brought for the purpose of harassment.
- vi. The person who is the subject of the matter has already taken corrective action and the commission believes the action taken was appropriate in the circumstances and the matter should not be pursued.
- vii. The commission has already taken action on the matter.
- viii. There are other reasonable grounds for not taking action.

#### (4) Decisions

(a) As expeditiously as possible but in any event within 120 days after the meeting at which the commission first considered the Inquiry and any response received from the Subject, the commission will decide that (1) the Inquiry requires no further action because it was resolved or did not require further review under subsection (c)(3)(d) hereof, or (2) probable cause exists that a violation of the Code occurred, in which case the Inquiry will be treated as a Complaint under subsection (d) hereof. The commission may extend the time for decision if circumstances justify a delay.

(b) No finding of the existence of probable cause may be made except upon the vote of at least four (4) members of the commission.

(c) Within 3 business days after making a decision under this subsection (c), the commission will inform in writing any person who filed an Inquiry and the person who is the subject of the investigation of its decision and of its reasons for the decision.

#### (5) Confidentiality

If the commission does not make a finding of probable cause, then the Inquiry and the record of the commission's investigation shall remain confidential, except upon the request of the person who was the subject of the Inquiry.

#### (d) Complaints

##### (1) Initiation

(a) After conducting an investigation of any Inquiry under subsection (c) hereof, if the commission finds probable cause exists, then it will make public its findings and its record of the investigation not later than 5 business days after its decision, except it may postpone public release of the record for up to 14 days for the purpose of resolving the matter with the person who is the subject of the Inquiry. If no resolution is reached, the commission will proceed in the manner described in this subsection (d).

(b) The findings and record of the investigation shall include: (1) the Inquiry; (2) evidence received or considered; (3) a reference to the particular section of the Code involved; and (4) a short and plain statement of the commission's reason for finding probable cause.

(c) Any member of the public who desires to file a Complaint against a current officer, official, consultant or employee for allegedly violating the Code must first pursue the matter as an Inquiry under subsection (c) hereof.

##### (2) Public Hearings

If the commission decides, after its investigation under subsection (c) hereof, that probable cause of a violation of the Code exists, it will conduct a public hearing to determine whether or not a violation occurred. At the hearing, the person who is the subject of the hearing will have the right to be represented by legal counsel, to present evidence and witnesses and compel attendance of witnesses and the production of books, documents, records and papers, and to examine and cross-examine witnesses and inspect and copy relevant and material records, papers and documents not in such person's possession. Not later than 10 days before the start of the hearing, the commission will provide the person with a list of its intended witnesses. The commission will make a record of the proceedings.



### (3) Powers and Conduct of Hearings

(a) For the hearing, the commission will have the power to administer oaths, question witnesses, consider oral and documentary evidence, subpoena witnesses under procedural rules adopted by the commission as regulations in accordance with the provisions of Chapter 54 of the Connecticut General Statutes (Uniform Administrative Procedure Act) to compel attendance before the commission, and require the production for examination by the commission of any books and papers which it deems relevant in any matter under investigation or in question.

(b) The commission may require witnesses to testify under oath administered by the presiding officer or any other duly qualified person. The hearings shall be recorded and/or transcribed.

(c) Hearings are not governed by the legal rules of evidence and any information relevant to the matter may be considered. The commission will respect the rules of privilege recognized by the law. When a hearing will be expedited and the interests of the parties will not be prejudiced substantially, any part of the evidence may be received in written form. Documentary evidence may be received in the form of copies or excerpts, if the original is not readily available, and, upon request, parties and the commission will be given an opportunity to compare the copy with the original.

### (4) Decisions

(a) Decisions by the commission that a person is in violation of the Code must result from the concurring vote of 4 of its members.

(b) The commission must render its decision within 60 days of the closing of the hearing.

(c) Such finding and memorandum will be deemed to be the final decision of the commission for the purposes of Chapter 54 of the Connecticut General Statutes. The person who was the subject of the hearing may appeal to the Superior Court in accordance with the provisions of Section 4-183 of the Connecticut General Statutes.

(d) If the commission finds that the Code was violated, it will provide the party who was the subject of the hearing and the Glastonbury Town Council with a copy of its findings and memorandum within 10 days after its decision. It will also advise the party of the right of appeal under Section 4-183 of the Connecticut General Statutes. At the same time, it will provide a copy of its findings and memorandum to the Glastonbury Town Manager, if such party is an employee, consultant or official appointed or under the jurisdiction of the Town Manager, or the Superintendent of Schools and the Board of Education of the Town of Glastonbury if such person is an employee, consultant or official appointed or under the jurisdiction of the Superintendent or such Board.

(e) Other Communications; Miscellaneous

(1) Other Communications.

The commission welcomes communications from the public even if they do not fall within the categories of an Advisory Opinion, Inquiry, or Complaint. These should be in writing and should include the name and address of the individual making the communication. The communication should be addressed to the chair of the commission, c/o the Glastonbury Town Clerk, 2155 Main Street, Town Hall, Glastonbury, Connecticut. Promptly after its receipt by the Town Clerk, the Clerk will forward a copy of the communication to the chair of the commission and will maintain the original in a confidential, indexed file until the chair or vice chair determines whether the request should be treated as confidential. Requests that are not treated as confidential will be available for public inspection. Communications will be handled on a case-by-case basis and at the discretion of the commission.

(2) Miscellaneous.

(a) As used in this Section 2-69, the term “business day” means a day other than a Saturday, Sunday or other day on which the office of the Glastonbury Town Clerk is closed to the public for business.

(b) Any proceeding undertaken by the commission to render an Advisory Opinion or investigate a possible violation of the Code will be governed by the Code and this Section 2-69.

(c) The commission may publish decisions in whole or in part if it decides that publication would serve the public interest and publication can be made in such a way as to protect the personal identity and privacy of persons who were the subject of any evaluation of a possible violation of the Code.

**Sec. 2-70. Effective date**

Nothing in the code of ethics shall impair or affect any act done, offense committed or right accruing, accrued or acquired, or an obligation, liability, penalty, forfeiture or punishment incurred prior to August 1, 2003, and the same may be enjoyed, asserted and enforced, as fully and to the same extent and in the same manner as they might under the laws existing prior to said date, and all matters pending on said date or instituted thereafter for any act done, offense committed, right accruing, accrued, or acquired, or obligation, liability, penalty, forfeiture, or punishment incurred prior to said date may be continued or instituted under and in accordance with the provisions of the ordinances and laws in effect at the time of the commission of said act done, offense committed, right accruing, accrued, or acquired, or obligation, liability, penalty, forfeiture, or punishment incurred.

(Ord. No. 296, 7-8-03)

**Sec. 2-71. Reserved.**

**TOWN OF GLASTONBURY  
CODE OF ETHICS  
ACKNOWLEDGEMENT FORM**

I HEREBY ACKNOWLEDGE that I have received and read the following materials:

\*Code of Ethics of the Town of Glastonbury

\*Section 1101 of the Glastonbury Charter (Conflict of Interest)

I ACKNOWLEDGE that as a Town Official, Consultant, or other party doing business with the Town, my conduct must conform to the ethical requirements specified in the Code and Town Charter (Section 1101-Conflict of Interest).

I FURTHER ACKNOWLEDGE that I have an ongoing obligation to notify the Town if I become aware of a conflict and that the Ethics Commission is available to render advisory opinions concerning potential conflicts of interest.

**If you hold an elected or appointed position for the Town of Glastonbury please complete this section:**

<b>Name:</b>	_____	<b>Phone Number:</b>	_____
<b>Elected or Appointed Position:</b>	_____	<b>e-mail address (optional):</b>	_____
<b>Address:</b>	_____		
<b>Date:</b>	_____	<b>Signature:</b>	_____

**If you are a vendor, supplier, or consultant for the Town of Glastonbury please complete this section:**

<b>Name:</b>	_____	<b>Phone Number:</b>	_____
<b>Title:</b>	_____	<b>e-mail address (optional):</b>	_____
<b>Company Name:</b>	_____		
<b>Address</b>	_____		
<b>Date:</b>	_____	<b>Signature:</b>	_____

THIS PAGE INTENTIONALLY LEFT BLANK

Project: Glastonbury East Hartford Magnet School, Phase III Of IV

**Minimum Rates and Classifications  
for Building Construction**

ID# : B 16124

**Connecticut Department of Labor  
Wage and Workplace Standards Division**

By virtue of the authority vested in the Labor Commissioner under provisions of Section 31-53 of the General Statutes of Connecticut, as amended, the following are declared to be the prevailing rates and welfare payments and will apply only where the contract is advertised for bid within 20 days of the date on which the rates are established. Any contractor or subcontractor not obligated by agreement to pay to the welfare and pension fund shall pay this amount to each employee as part of his/her hourly wages.

Project Number: 054-00995

Project Town Glastonbury

State#:

FAP#:

Project: Glastonbury East Hartford Magnet School, Phase III Of IV

**CLASSIFICATION**

**Hourly Rate**

**Benefits**

1a) Asbestos Worker/Insulator (Includes application of insulating materials, protective coverings, coatings, & finishes to all types of mechanical systems; application of firestopping material for wall openings & penetrations in walls, floors, ceilings - Last updated 7/21/11

36.86

25.51

1b) Asbestos/Toxic Waste Removal Laborers: Asbestos removal and encapsulation (except its removal from mechanical systems which are not to be scrapped), toxic waste removers, blasters. \*\*See Laborers Group 7\*\*

2) Boilermaker

34.94

19.00

**As of: Thursday, March 01, 2012**

Project: Glastonbury East Hartford Magnet School, Phase III Of IV

3a) Bricklayer, Cement Mason, Concrete Finisher (including caulking), Stone Masons	32.50	24.20 + a
3b) Tile Setter	32.00	21.44
3c) Terrazzo Mechanics and Marble Setters	31.69	22.35
3d) Tile, Marble & Terrazzo Finishers	25.50	24.20
3e) Plasterer	32.50	24.20

-----LABORERS-----

**As of: Thursday, March 01, 2012**

Project: Glastonbury East Hartford Magnet School, Phase III Of IV

4) Group 1: Laborers (common or general), acetylene burners, carpenter tenders, concrete specialists, wrecking laborers, fire watchers.	25.75	15.60
4a) Group 2: Mortar mixers, plaster tender, power buggy operators, powdermen, fireproofers/mixer/nozzleman, fence erector.	26.00	15.60
4b) Group 3: Jackhammer operators, mason tender (brick) and mason tender (cement/concrete)	26.25	15.60
4c) **Group 4: Pipelayers (Installation of water, storm drainage or sewage lines outside of the building line with P6, P7 license) (the pipelayer rate shall apply only to one or two employees of the total crew who primary task is to actually perform the mating of pipe sections)[If using this classification call the Labor Department for clarification]	26.00	15.60
4d) Group 5: Air track operators, Sand blasters	26.50	15.60
4e) Group 6: Nuclear toxic waste removers, blasters	28.75	15.60

***As of: Thursday, March 01, 2012***

Project: Glastonbury East Hartford Magnet School, Phase III Of IV

4f) Group 7: Asbestos removal and encapsulation (except it's removal from mechanical systems which are not to be scrapped)	26.75	15.60
--	-------	-------

4g) Group 8: Bottom men on open air caisson, cylindrical work and boring crew	26.25	15.60
---	-------	-------

4h) Group 9: Top men on open air caisson, cylindrical work and boring crew	25.75	15.60
--	-------	-------

4i) Group 10: Traffic Control Signalman	16.00	15.60
---	-------	-------

5) Carpenter, Acoustical Ceiling Installation, Soft Floor/Carpet Laying, Metal Stud Installation, Form Work and Scaffold Building, Drywall Hanging, Modular-Furniture Systems Installers, Lathers, Piledrivers, Resilient Floor Layers.	29.11	20.29
---	-------	-------

5a) Millwrights	30.01	20.18
-----------------	-------	-------



Project: Glastonbury East Hartford Magnet School, Phase III Of IV

6) Electrical Worker (including low voltage wiring) (Trade License required: E1,2 L-5,6 C-5,6 T-1,2 L-1,2 V-1,2,7,8,9)	36.40	21.31
7a) Elevator Mechanic (Trade License required: R-1,2,5,6)	45.97	23.535+a+b
-----LINE CONSTRUCTION-----		
Groundman	23.80	3% + 13.70
Linemen/Cable Splicer	43.28	3% + 13.70
8) Glazier (Trade License required: FG-1,2)	32.73	16.35 + a

**As of: Thursday, March 01, 2012**

Project: Glastonbury East Hartford Magnet School, Phase III Of IV

9) Ironworker, Ornamental, Reinforcing, Structural, and Precast Concrete Erection	33.50	27.03 + a
---	-------	-----------

----OPERATORS----

Group 1: Crane handling or erecting structural steel or stone, hoisting engineer 2 drums or over, front end loader (7 cubic yards or over); work boat 26 ft. and over. (Trade License Required)	35.05	19.40 + a
---	-------	-----------

Group 2: Cranes (100 ton rate capacity and over); Backhoe/Excavator over 2 cubic yards; Piledriver (\$3.00 premium when operator controls hammer). (Trade License Required)	34.73	19.40 + a
---	-------	-----------

Group 3: Excavator; Backhoe/Excavator under 2 cubic yards; Cranes (under 100 ton rated capacity), Grader/Blade; Master Mechanic; Hoisting Engineer (all types of equipment where a drum and cable are used to hoist or drag material regardless of motive power of operation), Rubber Tire Excavator (Drott-1085 or similar); Grader Operator; Bulldozer Fine Grade. (slopes, shaping, laser or GPS, etc.).	33.99	19.40 + a
---	-------	-----------

Group 4: Trenching Machines; Lighter Derrick; Concrete Finishing Machine; CMI Machine or Similar; Koehring Loader (Skooper).	33.60	19.40 + a
--	-------	-----------

**As of: Thursday, March 01, 2012**

Project: Glastonbury East Hartford Magnet School, Phase III Of IV

Group 5: Specialty Railroad Equipment; Asphalt Paver; Asphalt Reclaiming Machine; Line Grinder; Concrete Pumps; Drills with Self Contained Power Units; Boring Machine; Post Hole Digger; Auger; Pounder; Well Digger; Milling Machine (over 24" Mandrell)	33.01	19.40 + a
Group 5 continued: Side Boom; Combination Hoe and Loader; Directional Driller; Pile Testing Machine.	33.01	19.40 + a
Group 6: Front End Loader (3 up to 7 cubic yards); Bulldozer (rough grade dozer).	32.70	19.40 + a
Group 7: Asphalt roller, concrete saws and cutters (ride on types), vermeer concrete cutter, Stump Grinder; Scraper; Snooper; Skidder; Milling Machine (24" and under Mandrell).	32.36	19.40 + a
Group 8: Mechanic, grease truck operator, hydroblaster; barrier mover; power stone spreader; welding; work boat under 26 ft.; transfer machine.	31.96	19.40 + a
Group 9: Front end loader (under 3 cubic yards), skid steer loader regardless of attachments, (Bobcat or Similar): forklift, power chipper; landscape equipment (including Hydroseeder).	31.53	19.40 + a

**As of: Thursday, March 01, 2012**

Project: Glastonbury East Hartford Magnet School, Phase III Of IV

Group 10: Vibratory hammer; ice machine; diesel and air, hammer, etc.	29.49	19.40 + a
Group 11: Conveyor, earth roller, power pavement breaker (whiphammer), robot demolition equipment.	29.49	19.40 + a
Group 12: Wellpoint operator.	29.43	19.40 + a
Group 13: Compressor battery operator.	28.85	19.40 + a
Group 14: Elevator operator; tow motor operator (solid tire no rough terrain).	27.71	19.40 + a
Group 15: Generator Operator; Compressor Operator; Pump Operator; Welding Machine Operator; Heater Operator.	27.30	19.40 + a

***As of: Thursday, March 01, 2012***

Project: Glastonbury East Hartford Magnet School, Phase III Of IV

Group 16: Maintenance Engineer/Oiler.	26.65	19.40 + a
---------------------------------------	-------	-----------

Group 17: Portable asphalt plant operator; portable crusher plant operator; portable concrete plant operator.	30.96	19.40 + a
---	-------	-----------

Group 18: Power safety boat; vacuum truck; zim mixer; sweeper; (Minimum for any job requiring a CDL license).	28.54	19.40 + a
---	-------	-----------

-----PAINTERS (Including Drywall Finishing)-----

10a) Brush and Roller	29.17	16.35
-----------------------	-------	-------

10b) Taping Only/Drywall Finishing	29.92	16.35
------------------------------------	-------	-------

**As of: Thursday, March 01, 2012**

Project: Glastonbury East Hartford Magnet School, Phase III Of IV

10c) Paperhanger and Red Label	29.67	16.35
10e) Blast and Spray	32.17	16.35
11) Plumber (excluding HVAC pipe installation) (Trade License required: P-1,2,6,7,8,9 J-1,2,3,4 SP-1,2)	38.67	24.46
12) Well Digger, Pile Testing Machine	33.01	19.40 + a
13) Roofer (composition)	31.11	16.94
14) Roofer (slate & tile)	31.61	16.94

***As of: Thursday, March 01, 2012***

Project: Glastonbury East Hartford Magnet School, Phase III Of IV

15) Sheetmetal Worker (Trade License required for HVAC and Ductwork: SM-1,SM-2,SM-3,SM-4,SM-5,SM-6)	32.27	29.33
---	-------	-------

16) Pipefitter (Including HVAC work) (Trade License required: S-1,2,3,4,5,6,7,8 B-1,2,3,4 D-1,2,3,4, G-1, G-2, G-8 & G-9)	38.67	24.46
--	-------	-------

-----TRUCK DRIVERS-----

17a) 2 Axle	27.88	15.71 + a
-------------	-------	-----------

17b) 3 Axle, 2 Axle Ready Mix	27.98	15.71 + a
-------------------------------	-------	-----------

17c) 3 Axle Ready Mix	28.03	15.71 + a
-----------------------	-------	-----------

**As of: Thursday, March 01, 2012**

Project: Glastonbury East Hartford Magnet School, Phase III Of IV

17d) 4 Axle, Heavy Duty Trailer up to 40 tons	28.08	15.71 + a
17e) 4 Axle Ready Mix	28.13	15.71 + a
17f) Heavy Duty Trailer (40 Tons and Over)	28.33	15.71 + a
17g) Specialized Earth Moving Equipment (Other Than Conventional Type on-the-Road Trucks and Semi-Trailers, Including Euclids)	28.13	15.71 + a
18) Sprinkler Fitter (Trade License required: F-1,2,3,4)	40.50	16.85 + a
19) Theatrical Stage Journeyman	22.22	6.53

**As of: Thursday, March 01, 2012**



Project: Glastonbury East Hartford Magnet School, Phase III Of IV

*Welders: Rate for craft to which welding is incidental.*

*\*Note: Hazardous waste removal work receives additional \$1.25 per hour for truck drivers.*

*\*\*Note: Hazardous waste premium \$3.00 per hour over classified rate*

Crane with 150 ft. boom (including jib) - \$1.50 extra

Crane with 200 ft. boom (including jib) - \$2.50 extra

Crane with 250 ft. boom (including jib) - \$5.00 extra

Crane with 300 ft. boom (including jib) - \$7.00 extra

Crane with 400 ft. boom (including jib) - \$10.00 extra

All classifications that indicate a percentage of the fringe benefits must be calculated at the percentage rate times the "base hourly rate".

Apprentices duly registered under the Commissioner of Labor's regulations on "Work Training Standards for Apprenticeship and Training Programs" Section 31-51-d-1 to 12, are allowed to be paid the appropriate percentage of the prevailing journeymen hourly base and the full fringe benefit rate, providing the work site ratio shall not be less than one full-time journeyman instructing and supervising the work of each apprentice in a specific trade.

*The Prevailing wage rates applicable to this project are subject to annual adjustments each July 1st for the duration of the project.*

*Each contractor shall pay the annual adjusted prevailing wage rate that is in effect each July 1st, as posted by the Department of Labor.*

*It is the contractor's responsibility to obtain the annual adjusted prevailing wage rate increases directly from the Department of Labor's website.*

*The annual adjustments will be posted on the Department of Labor's Web page: [www.ct.gov/dol](http://www.ct.gov/dol)*

*The Department of Labor will continue to issue the initial prevailing wage rate schedule to the Contracting Agency for the project.*

*All subsequent annual adjustments will be posted on our Web Site for contractor access.*

**As of: Thursday, March 01, 2012**

Project: Glastonbury East Hartford Magnet School, Phase III Of IV

*Effective October 1, 2005 - Public Act 05-50: any person performing the work of any mechanic, laborer, or worker shall be paid prevailing wage*

All Person who perform work ON SITE must be paid prevailing wage for the appropriate mechanic, laborer, or worker classification.

All certified payrolls must list the hours worked and wages paid to All Persons who perform work ON SITE regardless of their ownership i.e.: (Owners, Corporate Officers, LLC Members, Independent Contractors, et. al)

Reporting and payment of wages is required regardless of any contractual relationship alleged to exist between the contractor and such person.

**~~Unlisted classifications needed for work not included within the scope of the classifications listed may be added after award only as provided in the labor standards contract clause (29 CFR 5.5 (a) (1) (ii)).**

Please direct any questions which you may have pertaining to classification of work and payment of prevailing wages to the Wage and Workplace Standards Division, telephone (860)263-6790.

**As of: Thursday, March 01, 2012**

**Sec. 31-53b. Construction safety and health course. New miner training program. Proof of completion required for mechanics, laborers and workers on public works projects. Enforcement. Regulations. Exceptions.** (a) Each contract for a public works project entered into on or after July 1, 2009, by the state or any of its agents, or by any political subdivision of the state or any of its agents, described in subsection (g) of section 31-53, shall contain a provision requiring that each contractor furnish proof with the weekly certified payroll form for the first week each employee begins work on such project that any person performing the work of a mechanic, laborer or worker pursuant to the classifications of labor under section 31-53 on such public works project, pursuant to such contract, has completed a course of at least ten hours in duration in construction safety and health approved by the federal Occupational Safety and Health Administration or, has completed a new miner training program approved by the Federal Mine Safety and Health Administration in accordance with 30 CFR 48 or, in the case of telecommunications employees, has completed at least ten hours of training in accordance with 29 CFR 1910.268.

(b) Any person required to complete a course or program under subsection (a) of this section who has not completed the course or program shall be subject to removal from the worksite if the person does not provide documentation of having completed such course or program by the fifteenth day after the date the person is found to be in noncompliance. The Labor Commissioner or said commissioner's designee shall enforce this section.

(c) Not later than January 1, 2009, the Labor Commissioner shall adopt regulations, in accordance with the provisions of chapter 54, to implement the provisions of subsections (a) and (b) of this section. Such regulations shall require that the ten-hour construction safety and health courses required under subsection (a) of this section be conducted in accordance with federal Occupational Safety and Health Administration Training Institute standards, or in accordance with Federal Mine Safety and Health Administration Standards or in accordance with 29 CFR 1910.268, as appropriate. The Labor Commissioner shall accept as sufficient proof of compliance with the provisions of subsection (a) or (b) of this section a student course completion card issued by the federal Occupational Safety and Health Administration Training Institute, or such other proof of compliance said commissioner deems appropriate, dated no earlier than five years before the commencement date of such public works project.

(d) This section shall not apply to employees of public service companies, as defined in section 16-1, or drivers of commercial motor vehicles driving the vehicle on the public works project and delivering or picking up cargo from public works projects provided they perform no labor relating to the project other than the loading and unloading of their cargo.

(P.A. 06-175, S. 1; P.A. 08-83, S. 1.)

History: P.A. 08-83 amended Subsec. (a) by making provisions applicable to public works project contracts entered into on or after July 1, 2009, replacing provision re total cost of work with reference to Sec. 31-53(g), requiring proof in certified payroll form that new mechanic, laborer or worker has completed a 10-hour or more construction safety course and adding provision re new miner training program, amended Subsec. (b) by substituting "person" for "employee" and adding "or program", amended Subsec. (c) by adding "or in accordance with Federal Mine Safety and Health Administration Standards" and setting new deadline of January 1, 2009, deleted former Subsec. (d) re "public building", added new Subsec. (d) re exemptions for public service company employees and delivery drivers who perform no labor other than delivery and made conforming and technical changes, effective January 1, 2009.

# **Informational Bulletin**

## **THE 10-HOUR OSHA CONSTRUCTION SAFETY AND HEALTH COURSE**

(applicable to public building contracts entered into *on or after July 1, 2007*, where the total cost of all work to be performed is at least \$100,000)

- (1) This requirement was created by Public Act No. 06-175, which is codified in Section 31-53b of the Connecticut General Statutes (pertaining to the prevailing wage statutes);
- (2) The course is required for public building construction contracts (projects funded in whole or in part by the state or any political subdivision of the state) entered into on or after July 1, 2007;
- (3) It is required of private employees (not state or municipal employees) and apprentices who perform manual labor for a general contractor or subcontractor on a public building project where the total cost of all work to be performed is at least \$100,000;
- (4) The ten-hour construction course pertains to the ten-hour Outreach Course conducted in accordance with federal OSHA Training Institute standards, and, for telecommunications workers, a ten-hour training course conducted in accordance with federal OSHA standard, 29 CFR 1910.268;
- (5) The internet website for the federal OSHA Training Institute is [http://www.osha.gov/fso/ote/training/edcenters/fact\\_sheet.html](http://www.osha.gov/fso/ote/training/edcenters/fact_sheet.html);
- (6) The statutory language leaves it to the contractor and its employees to determine who pays for the cost of the ten-hour Outreach Course;
- (7) Within 30 days of receiving a contract award, a general contractor must furnish proof to the Labor Commissioner that all employees and apprentices performing manual labor on the project will have completed such a course;
- (8) Proof of completion may be demonstrated through either: (a) the presentation of a *bona fide* student course completion card issued by the federal OSHA Training Institute; *or* (2) the presentation of documentation provided to an employee by a trainer certified by the Institute pending the actual issuance of the completion card;
- (9) Any card with an issuance date more than 5 years prior to the commencement date of the construction project shall not constitute proof of compliance;

- (10) Each employer shall affix a copy of the construction safety course completion card to the certified payroll submitted to the contracting agency in accordance with Conn. Gen. Stat. § 31-53(f) on which such employee's name first appears;
- (11) Any employee found to be in non-compliance shall be subject to removal from the worksite if such employee does not provide satisfactory proof of course completion to the Labor Commissioner by the fifteenth day after the date the employee is determined to be in noncompliance;
- (12) Any such employee who is determined to be in noncompliance may continue to work on a public building construction project for a maximum of fourteen consecutive calendar days while bringing his or her status into compliance;
- (13) The Labor Commissioner may make complaint to the prosecuting authorities regarding any employer or agent of the employer, or officer or agent of the corporation who files a false certified payroll with respect to the status of an employee who is performing manual labor on a public building construction project;
- (14) The statute provides the minimum standards required for the completion of a safety course by manual laborers on public construction contracts; any contractor can exceed these minimum requirements; and
- (15) Regulations clarifying the statute are currently in the regulatory process, and shall be posted on the CTDOL website as soon as they are adopted in final form.
- (16) Any questions regarding this statute may be directed to the Wage and Workplace Standards Division of the Connecticut Labor Department via the internet website of <http://www.ctdol.state.ct.us/wgwkstnd/wgmenu.htm>; or by telephone at (860)263-6790.

**THE ABOVE INFORMATION IS PROVIDED EXCLUSIVELY AS AN EDUCATIONAL RESOURCE, AND IS NOT INTENDED AS A SUBSTITUTE FOR LEGAL INTERPRETATIONS WHICH MAY ULTIMATELY ARISE CONCERNING THE CONSTRUCTION OF THE STATUTE OR THE REGULATIONS.**

## Statute 31-55a

You are here: [DOL Web Site](#) ▶ [Wage and Workplace Standards](#) ▶ Statute 31-55a

### - Special Notice -

**To All State and Political Subdivisions, Their Agents, and Contractors**

**Connecticut General Statute 31-55a - Annual adjustments to wage rates by contractors doing state work.**

*Each contractor that is awarded a contract on or after October 1, 2002, for (1) the construction of a state highway or bridge that falls under the provisions of section 31-54 of the general statutes, or (2) the construction, remodeling, refinishing, refurbishing, rehabilitation, alteration or repair of any public works project that falls under the provisions of section 31-53 of the general statutes shall contact the Labor Commissioner on or before July first of each year, for the duration of such contract, to ascertain the prevailing rate of wages on an hourly basis and the amount of payment or contributions paid or payable on behalf of each mechanic, laborer or worker employed upon the work contracted to be done, and shall make any necessary adjustments to such prevailing rate of wages and such payment or contributions paid or payable on behalf of each such employee, effective each July first.*

- The prevailing wage rates applicable to any contract or subcontract awarded on or after October 1, 2002 are subject to annual adjustments each July 1st for the duration of any project which was originally advertised for bids on or after October 1, 2002.
- Each contractor affected by the above requirement shall pay the annual adjusted prevailing wage rate that is in effect each July 1st, as posted by the Department of Labor.
- It is the **contractor's** responsibility to obtain the annual adjusted prevailing wage rate increases directly from the Department of Labor's Web Site. The annual adjustments will be posted on the Department of Labor Web page: [www.ctdol.state.ct.us](http://www.ctdol.state.ct.us). For those without internet access, please contact the division listed below.
- The Department of Labor will continue to issue the initial prevailing wage rate schedule to the Contracting Agency for the project. All subsequent annual adjustments will be posted on our Web Site for contractor access.

**Any questions should be directed to the Contract Compliance Unit, Wage and Workplace Standards Division, Connecticut Department of Labor, 200 Folly Brook Blvd., Wethersfield, CT 06109 at (860)263-6790.**

←-- [Workplace Laws](#)

Published by the Connecticut Department of Labor, Project Management Office  
Last Updated: April 22, 2010

~NOTICE~

TO ALL CONTRACTING AGENCIES

Please be advised that Connecticut General Statutes Section 31-53, requires the contracting agency to certify to the Department of Labor, the total dollar amount of work to be done in connection with such public works project, regardless of whether such project consists of one or more contracts.

Please find the attached “Contracting Agency Certification Form” to be completed and returned to the Department of Labor, Wage and Workplace Standards Division, Public Contract Compliance Unit.

 Inquiries can be directed to (860)263-6543.

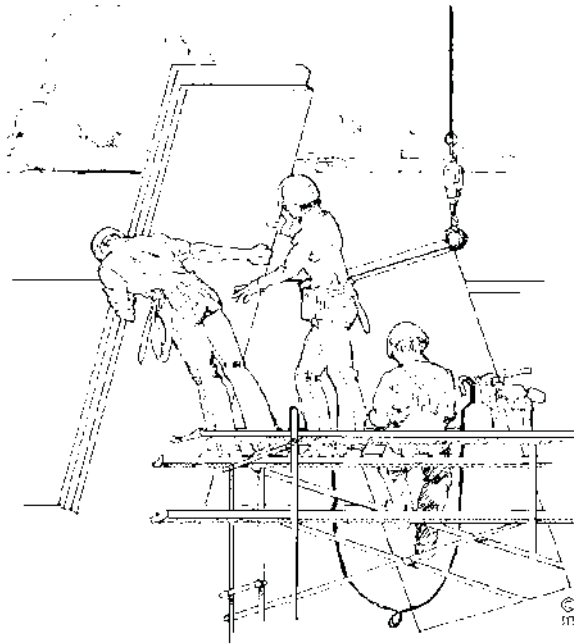



CONNECTICUT DEPARTMENT OF LABOR  
WAGE AND WORKPLACE STANDARDS DIVISION  
CONTRACT COMPLIANCE UNIT

*CONTRACTING AGENCY CERTIFICATION FORM*

I, \_\_\_\_\_, acting in my official capacity as \_\_\_\_\_,  
authorized representative title

for \_\_\_\_\_, located at \_\_\_\_\_,  
contracting agency address

do hereby certify that the total dollar amount of work to be done in connection with  
\_\_\_\_\_, located at \_\_\_\_\_,  
project name and number address

shall be \$\_\_\_\_\_, which includes all work, regardless of whether such project  
consists of one or more contracts.

*CONTRACTOR INFORMATION*

Name: \_\_\_\_\_

Address: \_\_\_\_\_

Authorized Representative: \_\_\_\_\_

Approximate Starting Date: \_\_\_\_\_

Approximate Completion Date: \_\_\_\_\_

\_\_\_\_\_  
Signature

\_\_\_\_\_  
Date

Return To: Connecticut Department of Labor  
Wage & Workplace Standards Division  
Contract Compliance Unit  
200 Folly Brook Blvd.  
Wethersfield, CT 06109

Date Issued: \_\_\_\_\_





**\*FRINGE BENEFITS EXPLANATION (P):**

Bona fide benefits paid to approved plans, funds or programs, except those required by Federal or State Law (unemployment tax, worker’s compensation, income taxes, etc.).

Please specify the type of benefits provided:

- 1) Medical or hospital care \_\_\_\_\_ 4) Disability \_\_\_\_\_
- 2) Pension or retirement \_\_\_\_\_ 5) Vacation, holiday \_\_\_\_\_
- 3) Life Insurance \_\_\_\_\_ 6) Other (please specify) \_\_\_\_\_

**CERTIFIED STATEMENT OF COMPLIANCE**

For the week ending date of \_\_\_\_\_,

I, \_\_\_\_\_ of \_\_\_\_\_, (hereafter known as Employer) in my capacity as \_\_\_\_\_ (title) do hereby certify and state:

**Section A:**

1. All persons employed on said project have been paid the full weekly wages earned by them during the week in accordance with Connecticut General Statutes, section 31-53, as amended. Further, I hereby certify and state the following:

- a) The records submitted are true and accurate;
- b) The rate of wages paid to each mechanic, laborer or workman and the amount of payment or contributions paid or payable on behalf of each such employee to any employee welfare fund, as defined in Connecticut General Statutes, section 31-53 (h), are not less than the prevailing rate of wages and the amount of payment or contributions paid or payable on behalf of each such employee to any employee welfare fund, as determined by the Labor Commissioner pursuant to subsection Connecticut General Statutes, section 31-53 (d), and said wages and benefits are not less than those which may also be required by contract;
- c) The Employer has complied with all of the provisions in Connecticut General Statutes, section 31-53 (and Section 31-54 if applicable for state highway construction);
- d) Each such employee of the Employer is covered by a worker’s compensation insurance policy for the duration of his employment which proof of coverage has been provided to the contracting agency;
- e) The Employer does not receive kickbacks, which means any money, fee, commission, credit, gift, gratuity, thing of value, or compensation of any kind which is provided directly or indirectly, to any prime contractor, prime contractor employee, subcontractor, or subcontractor employee for the purpose of improperly obtaining or rewarding favorable treatment in connection with a prime contract or in connection with a prime contractor in connection with a subcontractor relating to a prime contractor; and
- f) The Employer is aware that filing a certified payroll which he knows to be false is a class D felony for which the employer may be fined up to five thousand dollars, imprisoned for up to five years or both.

2. OSHA~The employer shall affix a copy of the construction safety course, program or training completion document to the certified payroll required to be submitted to the contracting agency for this project on which such employee’s name first appears.

\_\_\_\_\_  
(Signature) (Title) Submitted on (Date)

**Section B: Applies to CONNDOT Projects ONLY**

**That pursuant to CONNDOT contract requirements for reporting purposes only, all employees listed under Section B who performed work on this project are not covered under the prevailing wage requirements defined in Connecticut General Statutes Section 31-53.**

\_\_\_\_\_  
(Signature) (Title) Submitted on (Date)

Note: CTDOL will assume all hours worked were performed under Section A unless clearly delineated as Section B WWS-CP1 as such. Should an employee perform work under both Section A and Section B, the hours worked and wages paid must be segregated for reporting purposes.

**\*\*\*THIS IS A PUBLIC DOCUMENT\*\*\*  
\*\*\*DO NOT INCLUDE SOCIAL SECURITY NUMBERS\*\*\***



## Information Bulletin

### *Occupational Classifications*

The Connecticut Department of Labor has the responsibility to properly determine "job classification" on prevailing wage projects covered under C.G.S. Section 31-53.

*Note: This information is intended to provide a sample of some occupational classifications for guidance purposes only. It is not an all-inclusive list of each occupation's duties. This list is being provided only to highlight some areas where a contractor may be unclear regarding the proper classification.*

**Below are additional clarifications of specific job duties performed for certain classifications:**

- **ASBESTOS WORKERS**

Applies all insulating materials, protective coverings, coatings and finishes to all types of mechanical systems.

- **ASBESTOS INSULATOR**

Handle, install apply, fabricate, distribute, prepare, alter, repair, dismantle, heat and frost insulation, including penetration and fire stopping work on all penetration fire stop systems.

- **BOILERMAKERS**

Erects hydro plants, incomplete vessels, steel stacks, storage tanks for water, fuel, etc. Builds incomplete boilers, repairs heat exchanges and steam generators.

- **BRICKLAYERS, CEMENT MASONS, CEMENT FINISHERS, MARBLE MASONS, PLASTERERS, STONE MASONS, PLASTERERS. STONE MASONS, TERRAZZO WORKERS, TILE SETTERS**

Lays building materials such as brick, structural tile and concrete cinder, glass, gypsum, terra cotta block. Cuts, tools and sets marble, sets stone, finishes concrete, applies decorative steel, aluminum and plastic tile, applies cements, sand, pigment and marble chips to floors, stairways, etc.

- **CARPENTERS, MILLWRIGHTS. PILEDIVERMEN. LATHERS. RESILIENT FLOOR LAYERS, DOCK BUILDERS, DIKERS, DIVER TENDERS**

Constructs, erects, installs and repairs structures and fixtures of wood, plywood and wallboard. Installs, assembles, dismantles, moves industrial machinery. Drives piling into ground to provide foundations for structures such as buildings and bridges, retaining walls for earth embankments, such as cofferdams. Fastens wooden, metal or rockboard lath to walls, ceilings and partitions of buildings, acoustical tile layer, concrete form builder. Applies firestopping materials on fire resistive joint systems only. Installation of curtain/window walls only where attached to wood or metal studs. Installation of insulated material of all types whether blown, nailed or attached in other ways to walls, ceilings and floors of buildings. Assembly and installation of modular furniture/furniture systems. Free-standing furniture is not covered. This includes free standing: student chairs, study top desks, book box desks, computer furniture, dictionary stand, atlas stand, wood shelving, two-position information access station, file cabinets, storage cabinets, tables, etc.

- **CLEANING LABORER**

The clean up of any construction debris and the general cleaning, including sweeping, wash down, mopping, wiping of the construction facility, washing, polishing, dusting, etc., prior to the issuance of a certificate of occupancy falls under the *Labor classification*.

- **DELIVERY PERSONNEL**

If delivery of supplies/building materials is to one common point and stockpiled there, prevailing wages are not required. If the delivery personnel are involved in the distribution of the material to multiple locations within the construction site then they would have to be paid prevailing wages for the type of work performed: laborer, equipment operator, electrician, ironworker, plumber, etc.

An example of this would be where delivery of drywall is made to a building and the delivery personnel distribute the drywall from one "stockpile" location to further sub-locations on each floor. Distribution of material around a construction site is the job of a laborer/tradesman and not a delivery personnel.

- **ELECTRICIANS**

Install, erect, maintenance, alteration or repair of any wire, cable, conduit, etc., which generates, transforms, transmits or uses electrical energy for light, heat, power or other purposes, including the Installation or maintenance of telecommunication, LAN wiring or computer equipment, and low voltage wiring.

**\*License required per Connecticut General Statutes: E-1,2 L-5,6 C-5,6 T-1,2 L-1,2 V-1,2,7,8,9.**

- **ELEVATOR CONSTRUCTORS**

Install, erect, maintenance and repair of all types of elevators, escalators, dumb waiters and moving walks. **\*License required by Connecticut General Statutes: R-1,2,5,6.**

- **FORK LIFT OPERATOR**

Laborers Group 4) Mason Tenders - operates forklift solely to assist a mason to a maximum height of nine (9) feet only.

Power Equipment Operator Group 9 - operates forklift to assist any trade, and to assist a mason to a height over nine (9) feet.

- **GLAZIERS**

Glazing wood and metal sash, doors, partitions, and 2 story aluminum storefronts. Installs glass windows, skylights, store fronts and display cases or surfaces such as building fronts, interior walls, ceilings and table tops and metal store fronts. Installation of aluminum window walls and curtain walls is the "joint" work of glaziers and ironworkers which requires either a blended rate or equal composite workforce.

- **IRONWORKERS**

Erection, installation and placement of structural steel, precast concrete, miscellaneous iron, ornamental iron, metal curtain wall, rigging and reinforcing steel. Handling, sorting, and installation of reinforcing steel (rebar). Metal bridge rail (traffic), metal bridge handrail, and decorative security fence installation. Installation of aluminum window walls and curtain walls is the "joint" work of glaziers and ironworkers which requires either a blended rate or equal composite workforce. Insulated metal and insulated composite panels are still installed by the Ironworker.

- **INSULATOR**

Installing fire stopping systems/materials for "Penetration Firestop Systems": transit to cables, electrical conduits, insulated pipes, sprinkler pipe penetrations, ductwork behind radiation, electrical cable trays, fire rated pipe penetrations, natural polypropylene, HVAC ducts, plumbing bare metal, telephone and communication wires, and boiler room ceilings. Past practice using the applicable licensed trades, Plumber, Sheet Metal, Sprinkler Fitter, and Electrician, is not inconsistent with the Insulator classification and would be permitted.



- **LABORERS**

Acetylene burners, asphalt rakers, chain saw operators, concrete and power buggy operator, concrete saw operator, fence and guard rail erector (except metal bridge rail (traffic), metal bridge handrail, and decorative security fence installation.), hand operated concrete vibrator operator, mason tenders, pipelayers (installation of storm drainage or sewage lines on the street only), pneumatic drill operator, pneumatic gas and electric drill operator, powermen and wagon drill operator, air track operator, block paver, curb setters, blasters, concrete spreaders.

- **PAINTERS**

Maintenance, preparation, cleaning, blasting (water and sand, etc.), painting or application of any protective coatings of every description on all bridges and appurtenances of highways, roadways, and railroads. Painting, decorating, hardwood finishing, paper hanging, sign writing, scenic art work and drywall hhg for any and all types of building and residential work.

- **LEAD PAINT REMOVAL**

Painter's Rate

1. Removal of lead paint from bridges.
2. Removal of lead paint as preparation of any surface to be repainted.
3. Where removal is on a Demolition project prior to reconstruction.

Laborer's Rate

1. Removal of lead paint from any surface NOT to be repainted.
2. Where removal is on a *TOTAL* Demolition project only.

- **PLUMBERS AND PIPEFITTERS**

Installation, repair, replacement, alteration or maintenance of all plumbing, heating, cooling and piping. ***\*License required per Connecticut General Statutes: P-1,2,6,7,8,9 J-1,2,3,4 SP-1,2 S-1,2,3,4,5,6,7,8 B-1,2,3,4 D-1,2,3,4.***

- **POWER EQUIPMENT OPERATORS**

Operates several types of power construction equipment such as compressors, pumps, hoists, derricks, cranes, shovels, tractors, scrapers or motor graders, etc. Repairs and maintains equipment. **\*License required, crane operators only, per Connecticut General Statutes.**

- **ROOFERS**

Covers roofs with composition shingles or sheets, wood shingles, slate or asphalt and gravel to waterproof roofs, including preparation of surface. (tear-off and/or removal of any type of roofing and/or clean-up of any and all areas where a roof is to be relaid)

- **SHEETMETAL WORKERS**

Fabricate, assembles, installs and repairs sheetmetal products and equipment in such areas as ventilation, air-conditioning, warm air heating, restaurant equipment, architectural sheet metal work, sheetmetal roofing, and aluminum gutters.

Fabrication, handling, assembling, erecting, altering, repairing, etc. of coated metal material panels and composite metal material panels when used on building exteriors and interiors as soffits, fascia, louvers, partitions, wall panel siding, canopies, cornice, column covers, awnings, beam covers, cladding, sun shades, lighting troughs, spires, ornamental roofing, metal ceilings, mansards, copings, ornamental and ventilation hoods, vertical and horizontal siding panels, trim, etc.

The sheet metal classification also applies to the vast variety of coated metal material panels and composite metal material panels that have evolved over the years as an alternative to conventional ferrous and non-ferrous metals like steel, iron, tin, copper, brass, bronze, aluminum, etc. Insulated metal and insulated composite panels are still installed by the Iron Worker. Fabrication, handling, assembling, erecting, altering, repairing, etc. of architectural metal roof, standing seam roof, composite metal roof, metal and composite bathroom/toilet partitions, aluminum gutters, metal and composite lockers and shelving, kitchen equipment, and walk-in coolers.

- **SPRINKLER FITTERS**

Installation, alteration, maintenance and repair of fire protection sprinkler systems.

**\*License required per Connecticut General Statutes: F-1,2,3,4.**

- **TILE MARBLE AND TERRAZZO FINISHERS**

Assists and tends the tile setter, marble mason and terrazzo worker in the performance of their duties.

- **TRUCK DRIVERS**

**Definitions:**

1) “Site of the work” (29 Code of Federal Regulations (CFR) 5.2(l)(b) is the physical place or places where the building or work called for in the contract will remain and any other site where a significant portion of the building or work is constructed, provided that such site is established specifically for the performance of the contract or project;

(a) Except as provided in paragraph (l) (3) of this section, job headquarters, tool yards, batch plants, borrow pits, etc. are part of the “site of the work”; provided they are dedicated exclusively, or nearly so, to the performance of the contract or project, and provided they are adjacent to “the site of work” as defined in paragraph (e)(1) of this section;

(b) Not included in the “site of the work” are permanent home offices, branch plant establishments, fabrication plants, tool yards etc, of a contractor or subcontractor whose location and continuance in operation are determined wholly without regard to a particular State or political subdivision contract or uncertain and indefinite periods of time involved of a few seconds or minutes duration and where the failure to count such time is due to consideration justified by industrial realities (29 CFR 785.47)

2) “Engaged to wait” is waiting time that belongs to and is controlled by the employer which is an integral part of the job and is therefore compensable as hours worked. (29 CFR 785.15)

3) “Waiting to be engaged” is waiting time that an employee can use effectively for their own purpose and is not compensable as hours worked. (29 CFR 785.16)

4) “De Minimus” is a rule that recognizes that unsubstantial or insignificant periods of time which cannot as a practical administrative matter be precisely recorded for payroll purposes, may be disregarded. This rule applies only where there are uncertain and indefinite periods of time involved of a short duration and where the failure to count such time is due to consideration justified by worksite realities. For example, with respect to truck drivers on prevailing wage sites, this is typically less than 15 minutes at a time.

**Coverage of Truck Drivers on State or Political subdivision Prevailing Wage Projects**

**Truck drivers are covered for payroll purposes under the following conditions:**

- Truck Drivers for time spent working on the site of the work.
- Truck Drivers for time spent loading and/or unloading materials and supplies on the site of the work, if such time is not de minimus

- Truck drivers transporting materials or supplies between a facility that is deemed part of the site of the work and the actual construction site.
- Truck drivers transporting portions of the building or work between a site established specifically for the performance of the contract or project where a significant portion of such building or work is constructed and the physical places where the building or work outlined in the contract will remain.

*For example: Truck drivers delivering asphalt are covered under prevailing wage while “engaged to wait” on the site and when directly involved in the paving operation, provided the total time is not “de minimus”*

**Truck Drivers are not covered in the following instances:**

- Material delivery truck drivers while off “the site of the work”
- Truck Drivers traveling between a prevailing wage job and a commercial supply facility while they are off the “site of the work”
- Truck drivers whose time spent on the “site of the work” is de minimus, such as under 15 minutes at a time, merely to drop off materials or supplies, including asphalt.

*These guidelines are similar to U.S. Labor Department policies. The application of these guidelines may be subject to review based on factual considerations on a case by case basis.*

**For example:**

- Material men and deliverymen are not covered under prevailing wage as long as they are not directly involved in the construction process. If, they unload the material, they would then be covered by prevailing wage for the classification they are performing work in: laborer, equipment operator, etc.
- Hauling material off site is not covered provided they are not dumping it at a location outlined above.
- Driving a truck on site and moving equipment or materials on site would be considered covered work, as this is part of the construction process.

*Any questions regarding the proper classification should be directed to:*

*Public Contract Compliance Unit  
Wage and Workplace Standards Division  
Connecticut Department of Labor  
200 Folly Brook Blvd, Wethersfield, CT 06109  
(860) 263-6543*

Connecticut Department of Labor  
Wage and Workplace Standards Division  
FOOTNOTES

Please Note: If the “Benefits” listed on the schedule for the following occupations includes a letter(s) (+ a or + a+b for instance), refer to the information below.

Benefits to be paid at the appropriate prevailing wage rate for the listed occupation.

If the “Benefits” section for the occupation lists only a dollar amount, disregard the information below.

**Bricklayers, Cement Masons, Cement Finishers, Concrete Finishers, Stone Masons**  
(Building Construction) and  
(Residential- Hartford, Middlesex, New Haven, New London and Tolland Counties)

- a. Paid Holiday: Employees shall receive 4 hours for Christmas Eve holiday provided the employee works the regularly scheduled day before and after the holiday. Employers may schedule work on Christmas Eve and employees shall receive pay for actual hours worked in addition to holiday pay.

**Elevator Constructors: Mechanics**

- a. Paid Holidays: New Year’s Day, Memorial Day, Independence Day, Labor Day, Veterans’ Day, Thanksgiving Day, Christmas Day, plus the Friday after Thanksgiving.
- b. Vacation: Employer contributes 8% of basic hourly rate for 5 years or more of service or 6% of basic hourly rate for 6 months to 5 years of service as vacation pay credit.

**Glaziers**

- a. Paid Holidays: Labor Day and Christmas Day.

**Power Equipment Operators**  
(Heavy and Highway Construction & Building Construction)

- a. Paid Holidays: New Year’s Day, Good Friday, Memorial day, Independence Day, Labor Day, Thanksgiving Day and Christmas Day, provided the employee works 3 days during the week in which the holiday falls, if scheduled, and if scheduled, the working day before and the working day after the holiday. Holidays falling on Saturday may be observed on Saturday, or if the employer so elects, on the preceding Friday.

Connecticut Department of Labor  
Wage and Workplace Standards Division  
FOOTNOTES

**Ironworkers**

- a. Paid Holiday: Labor Day provided employee has been on the payroll for the 5 consecutive work days prior to Labor Day.

**Laborers (Tunnel Construction)**

- a. Paid Holidays: New Year's Day, Memorial Day, Independence Day, Labor Day, Thanksgiving Day and Christmas Day. No employee shall be eligible for holiday pay when he fails, without cause, to work the regular work day preceding the holiday or the regular work day following the holiday.

**Roofers**

- a. Paid Holidays: July 4<sup>th</sup>, Labor Day, and Christmas Day provided the employee is employed 15 days prior to the holiday.

**Sprinkler Fitters**

- a. Paid Holidays: Memorial Day, July 4th, Labor Day, Thanksgiving Day and Christmas Day, provided the employee has been in the employment of a contractor 20 working days prior to any such paid holiday.

**Truck Drivers**

(Heavy and Highway Construction & Building Construction)

- a. Paid Holidays: New Year's Day, Memorial Day, Independence Day, Labor Day, Thanksgiving Day, Christmas day, and Good Friday, provided the employee has at least 31 calendar days of service and works the last scheduled day before and the first scheduled day after the holiday, unless excused.

**CODE** A-001  
**ITEM:** Wastebasket  
**MANUFACTURER:** Rubbermaid  
**MODEL:** 2956  
**FINISHES:** Gray  
  
**DIMENSIONS:** 14"L x 10"W x 15"H  
**DESCRIPTION:** 28.5 qt. capacity, Soft Wastebasket, Medium Size.

**KNEE CLEARANCE:** NA

**QUANTITY:**

<b>Code</b>	<b>A-001</b>	<b>Quantity</b>
<b>Room_Number</b>		
A101		1
A103		1
A104		1
A106		1
A107		1
A108		1
A111		1
A112		1
A113		1
A115		1
A117		1
A118		1
A119		1
A120		1
A122		1
A123		1
A124		1
A124A		1
A125		1
A126		3
A129		1
A130		1
B101		2
B107		1
B107A		1
B113		1
B114		1
B118		1
B118A		1
B126		2
B130		1
B131		1
B132		1
B134		1

B137	1
B138	1
B139	1
C104	1
C108	1
C110	5
C112	1
C120	1
A201	1
A202	1
A203	1
A204	1
A205	1
A206	1
A207	1
A208	1
A214	1
A215	1
B201	1
B202	1
B204	1
B205	1
B206	3
B214	1
<b>SUB TOTAL</b>	<b>68</b>

**IMAGE:**





**CODE:** A-002  
**ITEM:** Classroom Flag  
**MANUFACTURER:** School Specialty  
**MODEL:** 1303566-030  
**FINISHES:** America  
  
**DIMENSIONS:** 16" x 24" on 3/8" x 36" Staff  
**DESCRIPTION:** <div>Mounted classroom flag, Rail mounted flag holders provided by Whiteboard Contractor. Confirm ceiling clearance before ordering.<strong> ITEM MUST BE INSTALLED BY VENDOR</strong>.</div>

**KNEE CLEARANCE:** NA

**QUANTITY:**

Code	A-002	Quantity
Room_Number		
A101		1
A106		1
A107		1
A112		1
A113		1
A118		1
A119		1
A122		1
A125		1
A130		1
B118		1
B134		1
B138		1
C108		1
C111		1
C112		1
A201		1
A202		1
A203		1
A204		1
A205		1
A206		1
A207		1
A208		1
A214		1
A215		1
B201		1
B202		1
B204		1
B205		1
SUB TOTAL		30

IMAGE:



**CODE** A-003  
**ITEM:** USA Flag on Pole  
**MANUFACTURER:** School Specialty  
**MODEL:** 603570-030  
**FINISHES:** America

**DIMENSIONS:** 4'H x 6'W, Flag on 9'H Pole.

**DESCRIPTION:** U.S. Flag made of 100% Nylon material,sewn construction. Handcrafted pole has solid metal screw joint, tassels and cord. Matching solid cast top ornaments and weighting flag stand have jeweler's golden finish.

**KNEE CLEARANCE:** NA

**QUANTITY:**

Code	A-003	Quantity
Room_Number		
C103		1
SUB TOTAL		1

**IMAGE:**



**CODE** A-004  
**ITEM:** CT Flag on Pole  
**MANUFACTURER:** CVS Flags  
**MODEL:** Z02070104028P  
**FINISHES:** Connecticut

**DIMENSIONS:** 4'H x 6'W, Flag on 9'H Pole.

**DESCRIPTION:** <div>Connecticut State Flag parade set, Nylon Flag with pole hem, Leather tabs and gold fringe. 7&quot; gold plated metal eagle ornament, Gold cord and tassel and oak pole. <strong>ITEM MUST BE INSTALLED BY VENDOR</strong>.</div>

**KNEE CLEARANCE:** NA

**QUANTITY:**

Code	A-004	Quantity
Room_Number		
C103		1
SUB TOTAL		1

**IMAGE:**



**CODE** A-005  
**ITEM:** Large Garbage  
**MANUFACTURER:** Rubbermaid  
**MODEL:** 9W27-27 GY  
**FINISHES:** Gray  
  
**DIMENSIONS:** 28- 1/2"L x 23- 3/8"W x 36- 1/2"H  
**DESCRIPTION:** 50 Gal. Brute Big wheel container, Square, Plastic, Built in "rubber wheels and full width molded in handle, Attached lid.

**KNEE CLEARANCE:** NA

**QUANTITY:**

Code	A-005	Quantity
Room_Number		
B108		1
C111		3
SUB TOTAL		4

**IMAGE:**



**CODE** A-006  
**ITEM:** USA Flag Exterior  
**MANUFACTURER:** CVS Flags  
**MODEL:** Z01006001  
**FINISHES:** US- American - Nylon

**DIMENSIONS:** 6' x 8'

**DESCRIPTION:** <div>Recognized as America's # 1 choice of U.S. Flags. Expertly crafted using heavyweight bunting made of 100% nylon. These nylon flags offer lustrous beauty, superior wear plus excellent flyability even in the slightest breeze. Its popular price combined with its reputation as the true all-weather flag make it an outstanding value. <strong>ITEM MUST BE INSTALLED BY VENDOR.</strong></div>

**KNEE CLEARANCE:** NA

**QUANTITY:**

Code	A-006	Quantity
Room_Number		
B126		1
SUB TOTAL		1

**IMAGE:**



**CODE** A-007  
**ITEM:** CT Exterior Flag  
**MANUFACTURER:** CVS Flags  
**MODEL:** Z02070105001  
**FINISHES:** CT-State Flag - Nylon

**DIMENSIONS:** 6' x 8'

**DESCRIPTION:** <div>Make one of your habits in the "Land of Steady Habits" displaying a Connecticut state flag from CVS Flags. Our state flags are made with SolarMax 200 denier heavy duty outdoor nylon and finished with a white header and stunning brass grommets to insure maximum durability. This Connecticut flag is beautifully dyed with vibrant shades of blue, pure white, deep brown, and striking gold. Proudly made in the U.S.A, our Connecticut state flag will surely be the talk of any Constitution State / Nutmegger. In a variety of sizes, you can find a flag to fit any need. Don't wait to show your state some support, order you Connecticut flag today. <strong>ITEM MUST BE INSTALLED BY VENDOR.</strong></div>

**KNEE CLEARANCE:** NA

**QUANTITY:**

Code	A-007	Quantity
Room_Number		
B126		1
SUB TOTAL		1

**IMAGE:**



**CODE:** A-008  
**ITEM:** Pencil Sharpener  
**MANUFACTURER:** Stanley Bostitch  
**MODEL:** EPS8HD-BLK  
**FINISHES:** Metallic and Black Plastic  
  
**DIMENSIONS:** 4"W x 1/2"D x 4"H  
**DESCRIPTION:** Electric Plug In, Heavy duty pencil sharpener, 3 yr. Warranty, Angled cutter head, Safety Features, Tip saver technology.

**KNEE CLEARANCE:** NA

**QUANTITY:**

Code	A-008	Quantity
Room_Number		
A101		1
A106		1
A107		1
A112		1
A113		1
A118		1
A119		1
A122		1
A125		1
A130		1
B113		1
B118		1
B126		2
B134		1
B138		1
C108		1
C111		1
C112		1
A201		1
A202		1
A203		1
A204		1
A205		1
A206		1
A207		1
A208		1
A214		1
A215		1
B201		1
B202		1
B204		1
B205		1
<b>SUB TOTAL</b>		<b>33</b>



IMAGE:



**CODE** A-009  
**ITEM:** Pre K & K Rug  
**MANUFACTURER:** School Specialty  
**MODEL:** 334729-030  
**FINISHES:** NA

**DIMENSIONS:** 8'-3" x 11'-8" Oval

**DESCRIPTION:** Reading by the Book Rug, Every letter of the alphabet is shown on its own book with a cute image to help children connect the sound of each letter.

**KNEE CLEARANCE:** NA

**QUANTITY:**

Code	A-009	Quantity
Room_Number		
A101		1
A106		1
A107		1
A112		1
A113		1
A118		1
SUB TOTAL		6

**IMAGE:**



**CODE** A-010  
**ITEM:** 1st Grade Rug  
**MANUFACTURER:** Lakeshore  
**MODEL:** GG594  
**FINISHES:** NA

**DIMENSIONS:** 9'W x 12'L Rectangle

**DESCRIPTION:** World Rug, The seven continents and oceans are represented with easy to read text along with a compass to begin exploring with direction, 10 yr. Warranty.

**KNEE CLEARANCE:** NA

**QUANTITY:**

Code	A-010	Quantity
Room_Number		
A119		1
A130		1
B138		1
SUB TOTAL		3

**IMAGE:**



**CODE** A-011  
**ITEM:** 2nd Grade Rug  
**MANUFACTURER:** Kidcarpet  
**MODEL:** CK1412  
**FINISHES:** NA

**DIMENSIONS:** 8'-4"W x 11'-8"L Rectangle

**DESCRIPTION:** Discover America Rug, Features memorable state icons to help children learn about the United States of America.

**KNEE CLEARANCE:** NA

**QUANTITY:**

Code	A-011	
Room_Number		Quantity
A214		1
B202		1
B204		1
SUB TOTAL		3

**IMAGE:**



**CODE** A-012  
**ITEM:** 3rd Grade Rug  
**MANUFACTURER:** School Specialty  
**MODEL:** 509375  
**FINISHES:** NA

**DIMENSIONS:** 8'-4"W x 11'-8"L Rectangle

**DESCRIPTION:** World Explorer Rug, Designed with bright colors to teach children about basic geography, A lifetime abrasive wear and anti-static protection warranty.

**KNEE CLEARANCE:** NA

**QUANTITY:**

Code	A-012	Quantity
Room_Number		
A215		1
B201		1
B205		1
SUB TOTAL		3

**IMAGE:**



**CODE** A-013  
**ITEM:** 4th Grade Rug  
**MANUFACTURER:** Kidcarpet  
**MODEL:** CK1412  
**FINISHES:** NA

**DIMENSIONS:** 8-4"W x 11-8"L Rectangle

**DESCRIPTION:** Discover America Rug, Features memorable state icons to help children learn about the United States of America.

**KNEE CLEARANCE:** NA

**QUANTITY:**

<b>Code</b>	<b>A-013</b>	
<b>Room_Number</b>		<b>Quantity</b>
A201		1
A203		1
A205		1
<b>SUB TOTAL</b>		<b>3</b>

**IMAGE:**



**CODE** A-014  
**ITEM:** 5th Grade Rug  
**MANUFACTURER:** Kidcarpet  
**MODEL:** CK1412  
**FINISHES:** NA

**DIMENSIONS:** 8'-4"W x 11'-8"L Rectangle

**DESCRIPTION:** Discover America Rug, Features memorable state icons to help children learn about the United States of America.

**KNEE CLEARANCE:** NA

**QUANTITY:**

<b>Code</b>	<b>A-014</b>	
<b>Room_Number</b>		<b>Quantity</b>
A202		1
A204		1
A206		1
<b>SUB TOTAL</b>		<b>3</b>

**IMAGE:**



**CODE** A-015  
**ITEM:** Japanese Rug  
**MANUFACTURER:** Lakeshore  
**MODEL:** GG594  
**FINISHES:** NA

**DIMENSIONS:** 9'W x 12' L Rectangle

**DESCRIPTION:** World Rug, The seven continents and oceans are represented with easy to read text along with a compass to begin exploring with direction, 10 yr. Warranty.

**KNEE CLEARANCE:** NA

**QUANTITY:**

Code	A-015	Quantity
Room_Number		
C108		1
SUB TOTAL		1

**IMAGE:**





**CODE** A-016  
**ITEM:** Reading Rug  
**MANUFACTURER:** School Specialty  
**MODEL:** 334729-030  
**FINISHES:** NA  
**DIMENSIONS:** 8'-3" x 11'-8" Oval  
**DESCRIPTION:** Reading by the Book Rug, Every letter of the alphabet is shown on its own book with a cute image to help children connect the sound of each letter.

**KNEE CLEARANCE:** NA

**QUANTITY:**

**IMAGE:**



**CODE** A-017  
**ITEM:** Spec Ed Rug  
**MANUFACTURER:** Kidcarpet  
**MODEL:** CK4108  
**FINISHES:** NA

**DIMENSIONS:** 8'-3" x 11'-8" Oval

**DESCRIPTION:** Circlertime Around the World Rug, Handpainted look features the continents and oceans, &nbsp;the outer board contains letters of the alphabet in color blocks.

**KNEE CLEARANCE:** NA

**QUANTITY:**

Code	A-017	Quantity
Room_Number		
C111		1
SUB TOTAL		1

**IMAGE:**



**CODE** A-018  
**ITEM:** Folder & Tray Cubby Mail Slots  
**MANUFACTURER:** School Specialty  
**MODEL:** 265341-030  
**FINISHES:** Birch Veneer Panels  
  
**DIMENSIONS:** 47- 3/4"W x 40"H x 13"D  
**DESCRIPTION:** Unit weights 100lbs, 1/4"; Thick with removable shelves, Accommodates 20 students, stores up to 9"; x 12"; paper size, Includes 20 assorted color trays.

**KNEE CLEARANCE:** NA

**QUANTITY:**

Code	A-018	Quantity
Room_Number		
A101		1
A106		1
A107		1
A112		1
A113		1
A118		1
A119		1
A122		1
A130		1
B138		1
A201		1
A202		1
A203		1
A204		1
A205		1
A206		1
A214		1
A215		1
B201		1
B202		1
B204		1
B205		1
SUB TOTAL		22

**IMAGE:**



**CODE** A-019  
**ITEM:** Wheasel  
**MANUFACTURER:** Best-Rite  
**MODEL:** BES-759 PROMO  
**FINISHES:** Aluminum Frame with White Board  
  
**DIMENSIONS:** 4'W x 8'L  
**DESCRIPTION:** Panel is mounted on heavy aluminum and rotates on two pins in a horizontal plane, includes an accessory tray, casters move easily over carpet and can be stacked to save on space.

**KNEE CLEARANCE:** NA

**QUANTITY:**

<b>Code</b>	<b>A-019</b>	<b>Quantity</b>
<b>Room_Number</b>		
A101		1
A106		1
A107		1
A112		1
A113		1
A118		1
A119		1
A122		1
A130		1
B134		1
B138		1
C101		1
C111		1
A201		1
A202		1
A203		1
A204		1
A205		1
A206		1
A207		1
A208		1
A214		1
A215		1
B201		1
B202		1
B204		1
B205		1
<b>SUB TOTAL</b>		<b>27</b>

IMAGE:



**CODE** A-020  
**ITEM:** 1/2 Nursery Block Set  
**MANUFACTURER:** Community Playthings  
**MODEL:** B405  
**FINISHES:** Solid Wood with Clear Finish  
  
**DIMENSIONS:** 5 -1/2"L x 5- 1/2"W x 2- 3/4"H  
**DESCRIPTION:** Blocks include: 10 mini squares, 4 mini doubles, 3 mini quads, 2 mini ramps. For ages 2-8, Open ends, Screwed Joints, Modular Shaped blocks.

**KNEE CLEARANCE:** NA

**QUANTITY:**

Code	A-020	Quantity
Room_Number		
A101		1
A106		1
A107		1
A112		1
A113		1
A118		1
SUB TOTAL		6

**IMAGE:**



**CODE** A-021  
**ITEM:** Woodcrest Kitchen Set of 4  
**MANUFACTURER:** Community Playthings  
**MODEL:** C360  
**FINISHES:** Solid Wood

**DIMENSIONS:** Counter Top Heights: 24", 15"W x 22"L. Tallest unit: 39 - 1/2".

**DESCRIPTION:** For ages 2-8, Pinch-Free Hinges, Refrigerator and Vupboard backs are large enough for mirror or chalkboard covers, Every unit has a fuzzy bulletin backing for display or hanging purposes.

**KNEE CLEARANCE:** NA

**QUANTITY:**

Code	A-021	Quantity
Room_Number		
A106		1
A107		1
A118		1
SUB TOTAL		3

**IMAGE:**



**CODE** A-022  
**ITEM:** Dress Up Unit  
**MANUFACTURER:** Community Playthings  
**MODEL:** C705  
**FINISHES:** Solid Wood

**DIMENSIONS:** 41"H x 42"L x 15" W

**DESCRIPTION:** 7 Hooks and 6 holes to practice hanging clothes on hangers, On and off mobility wheels, Oval mirror attached to one side, 3 shallow totes on top and 3 extra wide ones on the bottom for optimal storage. Double sided unit can be accessed from both sides, has the option of up to 4 rotating accessory arches.

**KNEE CLEARANCE:** NA

**QUANTITY:**

Code	A-022	
Room_Number		Quantity
A106		1
A107		1
A118		1
SUB TOTAL		3

**IMAGE:**





**CODE** A-023  
**ITEM:** Groupwork Screen  
**MANUFACTURER:** Turnstone  
**MODEL:** TS4S  
**FINISHES:** Tackboard side- Breccia R115 Cristal fabric , Markerboard side- Laminate, Screen- 4799 Platinum paint.  
**DIMENSIONS:** 48"W x 1"D x 54"H  
**DESCRIPTION:** Available with markerboard on one side and tackboard on the other, unlockable casters, can use screens to close off work area, 5 yr Warranty.

**KNEE CLEARANCE:** NA

**QUANTITY:**

Code	A-023	Quantity
Room_Number		
A122		2
B134		4
A207		2
A208		2
SUB TOTAL		10

**IMAGE:**



**CODE** A-024  
**ITEM:** Paper Roll Cutter  
**MANUFACTURER:** School Specialty  
**MODEL:** 009129  
**FINISHES:** NA

**DIMENSIONS:** 38"L x 7"W x 8"H

**DESCRIPTION:** Double edge floating Knife, Easy loading and safe, All in one 36" roll paper cutter. Comes ready to use, All steel construction.

**KNEE CLEARANCE:** NA

**QUANTITY:**

Code	A-024	Quantity
Room_Number		
C111		1
SUB TOTAL		1

**IMAGE:**



**CODE** A-025  
**ITEM:** Self Healing Mat  
**MANUFACTURER:** School Specialty-Dahle Vantage  
**MODEL:** 409207  
**FINISHES:** NA  
  
**DIMENSIONS:** 24"W x 36"L  
**DESCRIPTION:** 1/8" Thick mat, with 5 layer-construction providing maximum durability. Grids are printed on a 1/2" scale, Available in 4 sizes in blue color.

**KNEE CLEARANCE:** NA

**QUANTITY:**

<b>Code</b>	<b>A-025</b>	<b>Quantity</b>
Room_Number		
C111		1
SUB TOTAL		1

**IMAGE:**

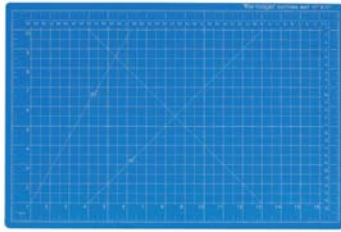

**CODE** A-026  
**ITEM:** Light Tracer  
**MANUFACTURER:** School Specialty- Artograph  
**MODEL:** 335062  
**FINISHES:** NA  
  
**DIMENSIONS:** 12W" x 18L" light surface  
**DESCRIPTION:** 5lb Light Tracer with recessed tray uses a 15-watt daylight fluorescent lamp (included), 5 yr. Warranty.

**KNEE CLEARANCE:** NA

**QUANTITY:**

Code	A-026	Quantity
Room_Number		
C111		6
SUB TOTAL		6

**IMAGE:**



**CODE** A-027  
**ITEM:** Wood Easel  
**MANUFACTURER:** School Specialty- Lobo Easel  
**MODEL:** 245435  
**FINISHES:** Hand-Rubbed, Oil-Finished, Solid Oak

**DIMENSIONS:** Base measures:24"W x 27"D, Height adjusts: 65"-95".

**DESCRIPTION:** A multitude of angle settings accommodate the watercolor, Pastel and oil painter. Handy features include a supply shelf underneath the frame, Adjustable painting tray, Retractable mast and bottom tray. Folds completely flat for storage. Holds canvases up to 55"

**KNEE CLEARANCE:** NA

**QUANTITY:**

Code	A-027	Quantity
Room_Number		
C111		1
SUB TOTAL		1

**IMAGE:**



**CODE** A-028  
**ITEM:** Plastic Art Cart  
**MANUFACTURER:** School Specialty- Rubbermaid  
**MODEL:** 034256  
**FINISHES:** Beige  
  
**DIMENSIONS:** 40- 3/8"L x 25 -1/2"W x 33"H  
**DESCRIPTION:** Easy to manuver cart includes 4 casters, 2 swivel and 2 fixed, contains 2 shelves each able to hold up to 200lb capacity.

**KNEE CLEARANCE:** NA

**QUANTITY:**

Code	A-028	Quantity
Room_Number		
C111		1
SUB TOTAL		1

**IMAGE:**



**CODE** A-029  
**ITEM:** Ware Cart  
**MANUFACTURER:** School Specialty- Debcor  
**MODEL:** 423155  
**FINISHES:** NA

**DIMENSIONS:** 24W" x 32L" x 54"H

**DESCRIPTION:** Made of heavy gauge steel, Dark Brown, Welded construction truck with 4" casters for easy mobility of wares. Excellent for cooling wares after firing. Can also be used for greenware drying. 12 plywood "half shelves" (12" x 28" x 1/2") for maximum flexibility. Space between shelves is 6-1/8", with boards 5-5/8".

**KNEE CLEARANCE:** NA

**QUANTITY:**

Code	A-029	Quantity
Room_Number		
C111		1
SUB TOTAL		1

**IMAGE:**



**CODE** A-030  
**ITEM:** Kiln Shelf  
**MANUFACTURER:** School Specialty-Skutt Furniture Kits for Kilns  
**MODEL:** 460262  
**FINISHES:** NA  
  
**DIMENSIONS:** 10- 5/8"W x 22"H x 5/8" Thick  
**DESCRIPTION:** Eight 5/8" thick half shelves, 1-1/2 triangular post assortment

**KNEE CLEARANCE:** NA

**QUANTITY:**

Code	A-030	Quantity
Room_Number		
C110		1
SUB TOTAL		1

**IMAGE:**





**CODE** A-031  
**ITEM:** Art Display Frames  
**MANUFACTURER:** Displays N Frames  
**MODEL:** Acrylic Wall Photo Frame  
**FINISHES:** NA

**DIMENSIONS:** 18"W x 24"L

**DESCRIPTION:** Frames are cut using High Tech CNC Routing Equipment, Polished by diamond or flame polisher. Images can be easily changed if or when required by simply unscrewing the wall mounting brackets and inserting a new photograph or poster. The panels are held together by Satin Chrome Sign Support fixings located in the four corners that are Brass for premium quality.

**KNEE CLEARANCE:** NA

**QUANTITY:**

Code	A-031	Quantity
Room_Number		
C110		50
SUB TOTAL		50

**IMAGE:**



**CODE** A-032  
**ITEM:** Storage Container w/ Lid  
**MANUFACTURER:** School Specialty  
**MODEL:** 357084  
**FINISHES:** Clear, Recyclable Plastic  
  
**DIMENSIONS:** 5- 1/2"W x 9- 1/2"L x 6- 3/4"H  
**DESCRIPTION:** Tough, high impact &nbsp;plastic bins with wide mouth openings.

**KNEE CLEARANCE:** NA

**QUANTITY:**

Code	A-032	Quantity
Room_Number		
C110		6
SUB TOTAL		6

**IMAGE:**



**CODE** A-033  
**ITEM:** Storage Bins  
**MANUFACTURER:** School Specialty- Akro-Mills  
**MODEL:** 1308003  
**FINISHES:** Yellow  
  
**DIMENSIONS:** 6- 5/8"W x 11- 5/8"L x 4"H  
**DESCRIPTION:** Molded from polypropylene, fits in 12" and 18" and 24" shelving, waterproof, and unharmed by oil or grease. Features a built in hang-lock wide label holder.

**KNEE CLEARANCE:** NA

**QUANTITY:**

Code	A-033	Quantity
Room_Number		
C110		24
SUB TOTAL		24

**IMAGE:**



**CODE** A-034  
**ITEM:** Storage Container w/ Lid  
**MANUFACTURER:** School Specialty- Rubbermaid Square Space Saving  
**MODEL:** 403401- container, 403404 - lid  
**FINISHES:** Clear  
  
**DIMENSIONS:** 403401: Container measures 14 -3/8"H x 10- 1/2"W x 11 -1/4"D, 403404: Lid measures 10 -  
**DESCRIPTION:** 22 qt. capacity, made of break-resistant clear polycarbonate, snap tight lids (sold seperately), containers nest for compact storage, dishwasher safe.<br><br>403401- container costs \$29.99 ea.<br>403404 - lid costs \$4.99 ea.

**KNEE CLEARANCE:** NA

**QUANTITY:**

Code	A-034	Quantity
Room_Number		
C110		6
SUB TOTAL		6

**IMAGE:**



**CODE** A-035  
**ITEM:** Storage Container w/ Lid  
**MANUFACTURER:** Rubbermaid  
**MODEL:** 403395 - container, 403403 - lid  
**FINISHES:** Clear  
  
**DIMENSIONS:** 403395: Container measures 6 -7/8"H x 8 -3/4"W x 8- 3/4" D, 403403: Lid measures 8 -3/4"  
**DESCRIPTION:** 6 qt. capacity, made of break-resistant polycarbonate, snap tight lids (sold seperately), containers nest for compact storage, dishwasher safe.<br><br>403395- container costs \$9.99 ea.<br>403403 - lid costs \$3.99 ea.

**KNEE CLEARANCE:** NA

**QUANTITY:**

Code	A-035	Quantity
Room_Number		
C110		6
SUB TOTAL		6

**IMAGE:**



**CODE** A-036  
**ITEM:** Equipment Cart  
**MANUFACTURER:** Brodart School Supplies & Furnishings  
**MODEL:** 84 521-84 524 001  
**FINISHES:** 1st choice Purple- 010, or 2nd choice Blue-006

**DIMENSIONS:** 34"H x 24"W x 18"D

**DESCRIPTION:** Durable, washable and waterproof thermoplastic material, Pebbled surface for &nbsp;no-slip shelves with grommets. 1/4" Thick retaining lips, holds up to 200lbs evenly distributed, easy rolling 4 casters (2 locking). Strong 1-1/4" square legs, molded in handle, Lifetime Warranty. 3-Outlet electrical unit.

**KNEE CLEARANCE:** 8-1/2" between top and middle shelf, 18-1/2" between middle and bottom shelf

**QUANTITY:**

Code	A-036	Quantity
Room_Number		
C112		1
SUB TOTAL		1

**IMAGE:**



**CODE** A-037  
**ITEM:** Music Stand  
**MANUFACTURER:** Cascio Interstate Music  
**MODEL:** Manhasset Model # 48 Symphony Music Stand  
**FINISHES:** Rugged, all aluminum, lightweight in textured finish in Yellow, Blue, Green, Orange, Purple, Red, White colors.  
**DIMENSIONS:** Desk measures:20" x 12-1/2", Stand height varies:26"-48".  
**DESCRIPTION:** Baked on, Glare free, Textured finish resists scratches and chipping. Easy, automatic no-knob friction-tilt neck delivers constant tension at any tilt position. Solid-brass bearings, greaseless heavy-duty chrome inner shaft, and the original counterbalanced "Magic Finger Clutch" provides one-hand friction grip. Secure at any height, even with a heavy load of music. Heavy-gauge, all-steel welded base provides excellent stability and requires minimum space on stage risers or in storage.  
 <br>  
 Color Quantities:<br>
 2 Yellow<br>
**KNEE CLEARANCE:** NA

**QUANTITY:**

Code	A-037	Quantity
Room_Number		
C112		13
SUB TOTAL		13

**IMAGE:**



**CODE** A-044  
**ITEM:** Music Board  
**MANUFACTURER:** Wenger Corp  
**MODEL:** Lesson Works Board  
**FINISHES:** Porcelain-Clad Whiteboard, Base is Grey Molded Polyethylene.

**DIMENSIONS:** White Board: 54" x 38", Base:40" x 25", Adjustable heights: 4'-6" or 5'-9".

**DESCRIPTION:** White board system- safe for dry-erase markers, easily converts different heights, contains permanent staves and magnetic music symbols. Large pocket in base, handholder grip system keeps lesson materials in place. Base rotates, white board flips with gas assisted spring lift, 4- 3&quot; casters (2 swivel, 2 stationary), 5 yr. Warranty.

**KNEE CLEARANCE:** NA

**QUANTITY:**

Code	A-044	Quantity
Room_Number		
C112		1
SUB TOTAL		1

**IMAGE:**





**CODE** A-045  
**ITEM:** Rotary Trimmer  
**MANUFACTURER:** Brodart School Supplies & Furnishings - Swingline  
**MODEL:** 42 318 001  
**FINISHES:** NA  
  
**DIMENSIONS:** 6"H x 16"W x 31"L  
**DESCRIPTION:** Enclosed stainless steel rotary blades cut in both directions, adjustable cutting guide, alignment grid, trims 1 sheet of tissue paper- 30 sheets of 20lb bond paper, 1 yr. Warranty.

**KNEE CLEARANCE:** NA

**QUANTITY:**

Code	A-045	Quantity
Room_Number		
C111		1
SUB TOTAL		1

**IMAGE:**



**CODE** A-046  
**ITEM:** Collapsible Cart  
**MANUFACTURER:** Brodart School Supplies & Furnishings- Pack-n-Roll  
**MODEL:** 49615001  
**FINISHES:** Black Plastic Frame, Aluminum Handle, Plastic Grip.  
**DIMENSIONS:** 18- 1/2"H x 16- 1/2"W x 16- 1/2"D, Folded Size:18- 1/2"H x 18 -1/2"W x 3- 1/2" D  
**DESCRIPTION:** Lightweight, durable, portable, 18- 1/2" telescoping handle, easy 1 2 3- unsnap two side clips, unfold cart sides and base, extend handle and go.

**KNEE CLEARANCE:** NA

**QUANTITY:**

Code	A-046	Quantity
Room_Number		
C111		1
SUB TOTAL		1

**IMAGE:**



**CODE** A-047  
**ITEM:** Globe  
**MANUFACTURER:** Brodart School Supplies & Furnishings  
**MODEL:** 82 867 001  
**FINISHES:** NA  
  
**DIMENSIONS:** 19" Over All Height, 12" Globe  
**DESCRIPTION:** George F. Cram Monmouth Globe Shows 5 land elevations, 2 water depths and land contours under the oceans. Finishes resist scratches, Raised Relief show political boundaries and physical features. Powder coated metal meridian and base.

**KNEE CLEARANCE:** NA

**QUANTITY:**

Code	A-047	Quantity
Room_Number		
B101		1
SUB TOTAL		1

**IMAGE:**



**CODE** A-048  
**ITEM:** Constellation Globe  
**MANUFACTURER:** Brodart School Supplies & Furnishings-Reprogle  
**MODEL:** 84084101  
**FINISHES:** NA  
  
**DIMENSIONS:** 16" Over all Height, 12" Globe  
**DESCRIPTION:** Two way illuminated star and constellation globe, with lights off lithography &nbsp;delineates stars, constellations and nebulae. Lights on display the zodiac images. Molded black base, smoke semi-meridian

**KNEE CLEARANCE:** NA

**QUANTITY:**

Code	A-048	Quantity
Room_Number		
B113		1
SUB TOTAL		1

**IMAGE:**



**CODE** A-050  
**ITEM:** Binding Machine  
**MANUFACTURER:** Demco- GBC  
**MODEL:** C 110  
**FINISHES:** NA

**DIMENSIONS:** 9"H x 14"W x 14"D

**DESCRIPTION:** Manually punches up to 15 sheets of 20 lb paper, Bind up to 300 sheets in 1-1/2" comb, Adjusts to letter size paper and oversize report covers. Document size guide measures documents to determine spine size, Unique comb opening guide speeds up loading time.

**KNEE CLEARANCE:** NA

**QUANTITY:**

Code	A-050	Quantity
Room_Number		
B113		1
SUB TOTAL		1

**IMAGE:**



**CODE** A-051  
**ITEM:** Long Range Stapler  
**MANUFACTURER:** Demco - Bostitch  
**MODEL:** P163-4068  
**FINISHES:** Black

**DIMENSIONS:** 12"L

**DESCRIPTION:** Adjustable paper stop extends up to 12"; has english and metric rulers, uses standard staples, Staples up to 20 sheets, handles materials in various sizes. Floating core prevents staple jams and power spring accomodates rugged handling, Rubber feet offer surface protection and stability. Stay back pusher allows full strip loading of staples, uses 210 staples.

**KNEE CLEARANCE:** NA

**QUANTITY:**

Code	A-051	Quantity
Room_Number		
B113		1
SUB TOTAL		1

**IMAGE:**



**CODE** A-052  
**ITEM:** Heavy Duty Stapler  
**MANUFACTURER:** Demco -Bostitch  
**MODEL:** P163-4050  
**FINISHES:** Black

**DIMENSIONS:** 5"H x 12"L x 3"W

**DESCRIPTION:** All metal, rear staple loading, contains an anti-jam stapling head and an adjustable paper stop, includes english and metric rulers, uses 100 heavy-duty staples (1,000 per box).

**KNEE CLEARANCE:** NA

**QUANTITY:**

Code	A-052	Quantity
Room_Number		
B113		1
SUB TOTAL		1

**IMAGE:**



**CODE** A-053  
**ITEM:** Die Cutter  
**MANUFACTURER:** Demco-AccuCut  
**MODEL:** P164-0237  
**FINISHES:** NA

**DIMENSIONS:** 7- 1/2"H x 26"W x 16"D

**DESCRIPTION:** Produces perfectly cut letters and shapes in just minutes, roller pressure preset, design allows for cutting from either direction without handling dies between cuts, 12" cutting area handles material without pre-cutting. Allows 7 different die sizes (can't cut giant dies), includes instruction manual, step by step instruction label, tool kit, die tray and die pick up for die cleaning.

**KNEE CLEARANCE:** NA

**QUANTITY:**

Code	A-053	
Room_Number		Quantity
B113		1
B126		2
SUB TOTAL		3

**IMAGE:**





**CODE** A-056  
**ITEM:** Bulletin Board  
**MANUFACTURER:** Claridge  
**MODEL:** 800 Series  
**FINISHES:** Aluminum frame (tack material to be specified)  
**DIMENSIONS:** 4'W x 6'L x 5/8" D  
**DESCRIPTION:** Tackboard, weights 30lbs.

**KNEE CLEARANCE:** NA

**QUANTITY:**

<b>Code</b>	<b>A-056</b>	<b>Quantity</b>
Room_Number		
B140		1
C101		2
SUB TOTAL		3

**IMAGE:**



**CODE** A-057  
**ITEM:** Totes  
**MANUFACTURER:** Sportime  
**MODEL:** 086505  
**FINISHES:** Natural Canvas  
  
**DIMENSIONS:** 14"H x 10-1/2"W x 5"D.  
**DESCRIPTION:** Heavy duty tote, can be used as a shoulder bag, natural cream colored canvas is machine washable.

**KNEE CLEARANCE:** NA

**QUANTITY:**

Code	A-057	Quantity
Room_Number		
C101		12
SUB TOTAL		12

**IMAGE:**



**CODE** A-058  
**ITEM:** Ball Racks  
**MANUFACTURER:** Sportime  
**MODEL:** 1281641  
**FINISHES:** Steel

**DIMENSIONS:** 55"W x 40"D x 41"H

**DESCRIPTION:** Super Ballrak has the storage and transport capacity to hold 48 basket balls in 8 rows of 6 each. Each of the 2 rows are supported on an independent 2 rail system that is slightly tilted to opposite sides to prevent the balls from leaning on each other.

**KNEE CLEARANCE:** NA

**QUANTITY:**

Code	A-058	Quantity
Room_Number		
C101		1
SUB TOTAL		1

**IMAGE:**



**CODE** A-059  
**ITEM:** Trash Containers Corridor  
**MANUFACTURER:** RPI  
**MODEL:** RR10-25  
**FINISHES:** Fiberglass  
  
**DIMENSIONS:** 30"H x 17" DIA  
**DESCRIPTION:** 25 Gallon fiberglass trash can with internal ring to support trash bags, aluminum protector plates are hardcoat anodized in dark gray.

**KNEE CLEARANCE:** NA

**QUANTITY:**

Code	A-059	Quantity
Room_Number		
B215		2
SUB TOTAL		2

**IMAGE:**



**CODE** A-060  
**ITEM:** 55 Gallon Brute Trash Can w/ Dolly  
**MANUFACTURER:** Rubbermaid  
**MODEL:** 2655-Brute container, 2640-43-Dolly  
**FINISHES:** Gray container, black dolly  
  
**DIMENSIONS:** Container measures- 33"H x 26 1/2"DIA, Dolly measures- 6/58"H x 18 1/4"DIA  
**DESCRIPTION:** Brute container is constructed of palstic, reinforced rims, built in handles, double ribbed base.<br><br>Dolly has red, non-marking wheels, quiet operation, loads up to 350lbs, constructed of plastic that resists chipping, rusting and denting.

**KNEE CLEARANCE:** NA

**QUANTITY:**

Code	A-060	Quantity
Room_Number		
C101		2
C111		2
C122		8
B206		1
SUB TOTAL		13

**IMAGE:**



**CODE** A-061  
**ITEM:** Recycle Container  
**MANUFACTURER:** Rubbermaid  
**MODEL:** 2956-73  
**FINISHES:** Blue plastic  
  
**DIMENSIONS:** 15" H x 10 1/4"W x 14 3/8"L  
**DESCRIPTION:** 28 qt capacity recycle container with recycle logo.

**KNEE CLEARANCE:** NA

**QUANTITY:**

<b>Code</b>	<b>A-061</b>	<b>Quantity</b>
<b>Room_Number</b>		
A101		1
A106		1
A107		1
A112		1
A113		1
A118		1
A119		1
A122		1
A123		1
A124		1
A124A		1
A125		1
A126		1
A130		1
B107		1
B107A		1
B108		1
B113		1
B114		1
B118		1
B118A		1
B119		1
B126		2
B132		1
B134		1
B138		1
C108		1
C112		1
C120		1
A201		1
A202		1
A203		1
A204		1
A205		1

A206	1
A207	1
A208	1
A214	1
A215	1
B201	1
B202	1
B204	1
B205	1
B206	1
B214	1
SUB TOTAL	46

IMAGE:



**CODE** A-062  
**ITEM:** Mop Buckets  
**MANUFACTURER:** Rubbermaid  
**MODEL:** 757688YW  
**FINISHES:** Yellow

**DIMENSIONS:** 24"D x 17"W

**DESCRIPTION:** 44 qt mop buckets with downwards pressure ringer, ,molded in wave baffles reduce water splashing up to 40% less. Heavy ergonomic wringer to exceed 50.000 cycles. Handy foot pedal drain for easy emptying, non-marking 3 casters, Constructed of tubular steel, and structural web molded plastic, for 16-32 oz mop heads.

**KNEE CLEARANCE:** NA

**QUANTITY:**

Code	A-062	Quantity
Room_Number		
B215		4
SUB TOTAL		4

**IMAGE:**





**CODE** A-063  
**ITEM:** Mini-White Boards  
**MANUFACTURER:** Best-Rite  
**MODEL:** BS15553  
**FINISHES:** NA

**DIMENSIONS:** 9.5"H x 11.5"W

**DESCRIPTION:** Lap Boards come in a set of 12, steel surface is magnetic, injection molded frame offer safer rounded edges. Plastic backing allows for outdoor use and to be completely washable.

**KNEE CLEARANCE:** NA

**QUANTITY:**

<b>Code</b>	<b>A-063</b>	<b>Quantity</b>
<b>Room_Number</b>		
A101		24
A106		24
A107		24
A112		24
A113		24
A118		24
A119		24
A122		12
A130		24
B118		24
B138		24
C108		24
C111		24
C112		24
A201		24
A202		24
A203		24
A204		24
A205		24
A206		24
A214		24
A215		24
B201		24
B202		24
B204		24
B205		24
<b>SUB TOTAL</b>		<b>612</b>

IMAGE:



**CODE:** A-064  
**ITEM:** Map Pack 1-Pre K-K  
**MANUFACTURER:** Nystromnet  
**MODEL:** 11ELS  
**FINISHES:** NA

**DIMENSIONS:** 65" x 53"

**DESCRIPTION:** <div>Early Learning Class Pack is brightly colored with correlated wall maps and globe that contain raised reliefs. Mounted on spring roller with backboard, globe with raised relief in gyro- disc mounting, &nbsp;16&quot; DIA. <strong>ITEM MUST BE INSTALLED BY VENDOR.</strong></div>

**KNEE CLEARANCE:** NA

**QUANTITY:**

Code	A-064	Quantity
Room_Number		
A101		1
A106		1
A107		1
A112		1
A113		1
A118		1
SUB TOTAL		6

**IMAGE:**



**CODE** A-065  
**ITEM:** Map Pack 2- Grades 1+2  
**MANUFACTURER:** Nystromnet  
**MODEL:** 11NS02  
**FINISHES:** NA

**DIMENSIONS:** 65" x 53"

**DESCRIPTION:** <div>Readiness Class Pack has bright colors and intriguing details. Continents, countries &nbsp;and cities are distinguished, land and water features are named as well as latitude, longitude lines are represented. Mounted on a spring roller with backboard, globe with raised relief in gyro-disc mounting, 16&quot; DIA. <strong>ITEM MUST BE INSTALLED BY VENDOR.</strong></div>

**KNEE CLEARANCE:** NA

**QUANTITY:**

Code	A-065	Quantity
Room_Number		
A119		1
A122		1
A130		1
B138		1
A214		1
B202		1
B204		1
SUB TOTAL		7

**IMAGE:**



**CODE** A-066  
**ITEM:** Map Pack 3-Grades 3+4  
**MANUFACTURER:** Nystromnet  
**MODEL:** 11MR  
**FINISHES:** NA

**DIMENSIONS:** 65" x 53"

**DESCRIPTION:** Intermediate Physical Class Pack contains earthy colors that mark regions of vegetation, relief shading dramatizes the lands 3-D shape, rivers are given special treatment to make it easy to trace them. Names of natural features, countires, states and major cities are labeled. Simple thematic maps enhance the value of the main map. Mounted on spring roller with backboard, globe with raised relief in gyro-disc mounting, 16" DIA. **ITEM MUST BE INSTALLED BY VENDOR.**

**KNEE CLEARANCE:** NA

**QUANTITY:**

Code	A-066	Quantity
Room_Number		
A201		1
A203		1
A205		1
A215		1
B201		1
B205		1
SUB TOTAL		6

**IMAGE:**



**CODE** A-067  
**ITEM:** Map Pack 4- Grade 5  
**MANUFACTURER:** Nystromnet  
**MODEL:** 11PL  
**FINISHES:** NA

**DIMENSIONS:** 65" x 53"

**DESCRIPTION:** <div>Intermediate Political Class Pack has brightly banded colors that highlight the shapes, sizes and locations of states and countries. Country and state names are in bold letters, city names are ranked by population size, major rivers are given special treatment making it easy to trace them. Simple thematic maps enhance the value of the main map, globe with raised relief in gyro-disc mounting, 16" DIA. <strong>ITEM MUST BE INSTALLED BY VENDOR.</strong></div>

**KNEE CLEARANCE:** NA

**QUANTITY:**

Code	A-067	Quantity
Room_Number		
C108		1
C111		1
C112		1
A202		1
A204		1
A206		1
SUB TOTAL		6

**IMAGE:**



**CODE** A-068  
**ITEM:** Child Cot  
**MANUFACTURER:** Mahar  
**MODEL:** MHR-500T  
**FINISHES:** Standard- Blue Fabric & Dustin Green Corner Legs

**DIMENSIONS:** 22" x 52"

**DESCRIPTION:** The lightweight Mahar Child Cot is easy to lift and move around the classroom, making it simple to get ready for naptime. Plastic legs fit in 2-inch corner holes so you can quickly stack up and store multiple cots. Open weave polyester cover won't absorb moisture or unravel and stretches tight over a steel frame. Made without screws or bolts to come loose. Includes labels to assign each kid their own cot. Meets fire code safety requirements and is backed by a ten-year warranty. Legs come in seven colors to match your décor. 80-pound weight cap

**KNEE CLEARANCE:** NA

**QUANTITY:**

Code	A-068	Quantity
Room_Number		
A105		20
A109		20
A116		20
SUB TOTAL		60

**IMAGE:**



**CODE** A-070  
**ITEM:** Bread Slicing Knife  
**MANUFACTURER:** Dexter  
**MODEL:** S46910  
**FINISHES:** NA  
  
**DIMENSIONS:** NA  
**DESCRIPTION:** Bread Slicing Knife

**KNEE CLEARANCE:** NA

**QUANTITY:**

<b>Code</b>	<b>A-070</b>	<b>Quantity</b>
Room_Number		
C118		2
SUB TOTAL		2

**IMAGE:**





**CODE** A-071  
**ITEM:** French Cook Knife  
**MANUFACTURER:** Dexter  
**MODEL:** S-145-10  
**FINISHES:** NA  
**DIMENSIONS:** 10" Blade  
**DESCRIPTION:** Cook Knife

**KNEE CLEARANCE:** NA

**QUANTITY:**

<b>Code</b>	<b>A-071</b>	<b>Quantity</b>
<b>Room_Number</b>		
C118		2
<b>SUB TOTAL</b>		2

**IMAGE:**



**CODE** A-072  
**ITEM:** Cake Turner Blade  
**MANUFACTURER:** Dexter  
**MODEL:** S286-8  
**FINISHES:** NA  
**DIMENSIONS:** 8" blade  
**DESCRIPTION:** Cake Turner Blade

**KNEE CLEARANCE:** NA

**QUANTITY:**

<b>Code</b>	<b>A-072</b>	<b>Quantity</b>
<b>Room_Number</b>		
C118		2
<b>SUB TOTAL</b>		2

**IMAGE:**



**CODE** A-073  
**ITEM:** Hamburger Turner  
**MANUFACTURER:** Dexter  
**MODEL:** S286-4  
**FINISHES:** NA  
**DIMENSIONS:** 4" Blade  
**DESCRIPTION:** Hamburger Turner

**KNEE CLEARANCE:** NA

**QUANTITY:**

<b>Code</b>	<b>A-073</b>	<b>Quantity</b>
Room_Number		
C118		2
SUB TOTAL		2

**IMAGE:**



**CODE** A-074  
**ITEM:** Sandwich Spreader  
**MANUFACTURER:** Dexter  
**MODEL:** S173  
**FINISHES:** NA  
  
**DIMENSIONS:** 3-1/2" Blade  
**DESCRIPTION:** Sandwich Spreader

**KNEE CLEARANCE:** NA

**QUANTITY:**

Code	A-074	Quantity
Room_Number		
C118		4
SUB TOTAL		4

**IMAGE:**



**CODE** A-075  
**ITEM:** Paring Knife  
**MANUFACTURER:** Dexter  
**MODEL:** S104  
**FINISHES:** NA  
  
**DIMENSIONS:** 3-1/2" Blade  
**DESCRIPTION:** Paring Knife

**KNEE CLEARANCE:** NA

**QUANTITY:**

<b>Code</b>	<b>A-075</b>	<b>Quantity</b>
Room_Number		
C118		6
SUB TOTAL		6

**IMAGE:**



**CODE** A-076  
**ITEM:** Vegetable Peeler  
**MANUFACTURER:** Dexter  
**MODEL:** 91500  
**FINISHES:** Polypropylene

**DIMENSIONS:** NA

**DESCRIPTION:** Vegetable Peeler has a stain free high carbon steel blade, slip resistant polypropylene handle.

**KNEE CLEARANCE:** NA

**QUANTITY:**

<b>Code</b>	<b>A-076</b>	<b>Quantity</b>
Room_Number		
C118		3
SUB TOTAL		3

**IMAGE:**



**CODE** A-077  
**ITEM:** All Purpose Disher 1  
**MANUFACTURER:** Vollrath  
**MODEL:** 47141  
**FINISHES:** Ivory

**DIMENSIONS:** 9-3/8" L, Size 10

**DESCRIPTION:** All Purpose Disher is a one piece molded handle made with Agion, stainless steel bowl that resists corrosion. Color coded handle for no guess size selection, extended grooved handle for sure grip and comfortable use. &nbsp;Blade extends beyond bowl to prevent sticking, dishwasher safe, makes accurate porportions, replacement spring is available.

**KNEE CLEARANCE:** NA

**QUANTITY:**

Code	A-077	Quantity
Room_Number		
C118		4
SUB TOTAL		4

**IMAGE:**



**CODE** A-078  
**ITEM:** All Purpose Disher 2  
**MANUFACTURER:** Vollrath  
**MODEL:** 47142  
**FINISHES:** Green

**DIMENSIONS:** 9-3/16"L, Size 12

**DESCRIPTION:** All Purpose Disher is a one piece molded handle made with Agion, stainless steel bowl that resists corrosion. Color coded handle for no guess size selection, extended grooved handle for sure grip and comfortable use. &nbsp;Blade extends beyond bowl to prevent sticking, dishwasher safe, makes accurate porportions, replacement spring is available.

**KNEE CLEARANCE:** NA

**QUANTITY:**

Code	A-078	Quantity
Room_Number		
C118		2
SUB TOTAL		2

**IMAGE:**





**CODE** A-079  
**ITEM:** All Purpose Disher 3  
**MANUFACTURER:** Vollrath  
**MODEL:** 47143  
**FINISHES:** Dark Blue

**DIMENSIONS:** 8-31/32"L, Size 16

**DESCRIPTION:** All Purpose Disher is a one piece molded handle made with Agion, stainless steel bowl that resists corrosion. Color coded handle for no guess size selection, extended grooved handle for sure grip and comfortable use. &nbsp;Blade extends beyond bowl to prevent sticking, dishwasher safe, makes accurate porportions, replacement spring is available.

**KNEE CLEARANCE:** NA

**QUANTITY:**

Code	A-079	Quantity
Room_Number		
C118		2
SUB TOTAL		2

**IMAGE:**



**CODE** A-080  
**ITEM:** All Purpose Disher 4  
**MANUFACTURER:** Vollrath  
**MODEL:** 47145  
**FINISHES:** Red

**DIMENSIONS:** 8-21/32"L, Size 24

**DESCRIPTION:** All Purpose Disher is a one piece molded handle made with Agion, stainless steel bowl that resists corrosion. Color coded handle for no guess size selection, extended grooved handle for sure grip and comfortable use. &nbsp;Blade extends beyond bowl to prevent sticking, dishwasher safe, makes accurate porportions, replacement spring is available.

**KNEE CLEARANCE:** NA

**QUANTITY:**

Code	A-080	Quantity
Room_Number		
C118		2
SUB TOTAL		2

**IMAGE:**



**CODE** A-081  
**ITEM:** SS Solid Basting Spoon  
**MANUFACTURER:** Vollrath  
**MODEL:** 64400  
**FINISHES:** Stainless Steel

**DIMENSIONS:** 11-3/4"L

**DESCRIPTION:** Solid Basting Spoon, resistant to corrosion, one piece construction is durable and sanitary, satin finish minimizes wear. Patented handle with turn down design for unrivaled strength and comfort.

**KNEE CLEARANCE:** NA

**QUANTITY:**

<b>Code</b>	<b>A-081</b>	<b>Quantity</b>
<b>Room_Number</b>		
C118		3
<b>SUB TOTAL</b>		3

**IMAGE:**



**CODE** A-082  
**ITEM:** Slotted Basting Spoon  
**MANUFACTURER:** Vollrath  
**MODEL:** 64405  
**FINISHES:** Stainless Steel

**DIMENSIONS:** 13-1/4"L

**DESCRIPTION:** Slotted Basting Spoon, resistant to corrosion, one piece construction is durable and sanitary, satin finish minimizes wear. Patented handle with turn down design for unrivaled strength and comfort.

**KNEE CLEARANCE:** NA

**QUANTITY:**

Code	A-082	Quantity
Room_Number		
C118		3
SUB TOTAL		3

**IMAGE:**



**CODE** A-083  
**ITEM:** Perforated Basting spoon  
**MANUFACTURER:** Vollrath  
**MODEL:** 64401  
**FINISHES:** Stainless Steel

**DIMENSIONS:** 11-3/4"L

**DESCRIPTION:** Perforated Basting Spoon, resistant to corrosion, one piece construction is durable and sanitary, satin finish minimizes wear. Patented handle with turn down design for unrivaled strength and comfort.

**KNEE CLEARANCE:** NA

**QUANTITY:**

<b>Code</b>	<b>A-083</b>	<b>Quantity</b>
<b>Room_Number</b>		
C118		3
<b>SUB TOTAL</b>		3

**IMAGE:**



**CODE** A-084  
**ITEM:** Ladle 1  
**MANUFACTURER:** Vollrath  
**MODEL:** 58620  
**FINISHES:** Stainless Steel  
  
**DIMENSIONS:** 9-7/8" L, 2 oz. capacity  
**DESCRIPTION:** Ladle has attractive bright finish, hooked handle to prevent sliding and easy storage, grooved handle for extra strength.

**KNEE CLEARANCE:** NA

**QUANTITY:**

Code	A-084	Quantity
Room_Number		
C118		4
SUB TOTAL		4

**IMAGE:**



**CODE** A-085  
**ITEM:** Ladle 2  
**MANUFACTURER:** Vollrath  
**MODEL:** 58460  
**FINISHES:** Stainless Steel  
  
**DIMENSIONS:** 12-3/8"L, 6 oz. capacity  
**DESCRIPTION:** Ladle has attractive bright finish, hooked handle to prevent sliding and easy storage, grooved handle for extra strength.

**KNEE CLEARANCE:** NA

**QUANTITY:**

Code	A-085	Quantity
Room_Number		
C118		2
SUB TOTAL		2

**IMAGE:**



**CODE** A-086  
**ITEM:** Ladle 3  
**MANUFACTURER:** Vollrath  
**MODEL:** 58480  
**FINISHES:** Stainless Steel  
  
**DIMENSIONS:** 12-5/8"L, 8 oz. capacity  
**DESCRIPTION:** Ladle has attractive bright finish, hooked handle to prevent sliding and easy storage, grooved handle for extra strength.

**KNEE CLEARANCE:** NA

**QUANTITY:**

Code	A-086	Quantity
Room_Number		
C118		2
SUB TOTAL		2

**IMAGE:**





**CODE** A-087  
**ITEM:** Cake Turner  
**MANUFACTURER:** Vollrath  
**MODEL:** 46934  
**FINISHES:** Stainless Steel  
  
**DIMENSIONS:** 14-1/4"L  
**DESCRIPTION:** Slotted Cake Turner has welded construction, flexible blade that measures: 3-1/32"

**KNEE CLEARANCE:** NA

**QUANTITY:**

Code	A-087	Quantity
Room_Number		
C118		1
SUB TOTAL		1

**IMAGE:**



**CODE** A-088  
**ITEM:** Funnel 1  
**MANUFACTURER:** Vollrath  
**MODEL:** 84760  
**FINISHES:** Stainless Steel  
  
**DIMENSIONS:** 22 oz. capacity / 6" Diameter  
**DESCRIPTION:** Funnel has a hanging ring for easy storage, has capacity markings for an easier selection.

**KNEE CLEARANCE:** NA

**QUANTITY:**

Code	A-088	Quantity
Room_Number		
C118		1
SUB TOTAL		1

**IMAGE:**



**CODE** A-089  
**ITEM:** Funnel 2  
**MANUFACTURER:** Vollrath  
**MODEL:** 84740  
**FINISHES:** Stainless Steel

**DIMENSIONS:** 6 3/8 oz. capacity / 4" Diameter

**DESCRIPTION:** Funnel has a hanging ring for easy storage, has capacity markings for an easier selection.

**KNEE CLEARANCE:** NA

**QUANTITY:**

<b>Code</b>	<b>A-089</b>	<b>Quantity</b>
Room_Number		
C118		1
SUB TOTAL		1

**IMAGE:**



**CODE** A-090  
**ITEM:** Scoop  
**MANUFACTURER:** Vollrath  
**MODEL:** 46892  
**FINISHES:** Cast Aluminum  
  
**DIMENSIONS:** 23 oz. scoop capacity, 8" x 4" Bowl size  
**DESCRIPTION:** Scoop is a one piece construction, round handle with ergonomic finger grips.

**KNEE CLEARANCE:** NA

**QUANTITY:**

Code	A-090	Quantity
Room_Number		
C118		1
SUB TOTAL		1

**IMAGE:**



**CODE** A-091  
**ITEM:** Measure Cap 1  
**MANUFACTURER:** Vollrath  
**MODEL:** 68352  
**FINISHES:** Aluminum

**DIMENSIONS:** 9-1/4"H, 4 qt. capacity

**DESCRIPTION:** Measure Cup is constructed of impact-resistant 3004 aluminum, specifically designed lip for no-spill pouring, each embossed bar denotes 1/4" measurements and has welded handles.

**KNEE CLEARANCE:** NA

**QUANTITY:**

Code	A-091	Quantity
Room_Number		
C118		2
SUB TOTAL		2

**IMAGE:**



**CODE** A-092  
**ITEM:** Measure Cap 2  
**MANUFACTURER:** Vollrath  
**MODEL:** 68296  
**FINISHES:** Aluminum

**DIMENSIONS:** 5-7/16"H, 1 qt. capacity

**DESCRIPTION:** Measure Cup is constructed of impact-resistant 3004 aluminum, specifically designed lip for no-spill pouring, each embossed bar denotes 1/4" measurements and has welded handles.

**KNEE CLEARANCE:** NA

**QUANTITY:**

<b>Code</b>	<b>A-092</b>	<b>Quantity</b>
Room_Number		
C118		2
SUB TOTAL		2

**IMAGE:**



**CODE** A-093  
**ITEM:** Measure Cap 3  
**MANUFACTURER:** Vollrath  
**MODEL:** 68297  
**FINISHES:** NA

**DIMENSIONS:** 4-3/16"H , 1/2 qt capacity

**DESCRIPTION:** Measure Cup is constructed of impact-resistant 3004 aluminum, specifically designed lip for no-spill pouring, each embossed bar denotes 1/4" measurements and has welded handles.

**KNEE CLEARANCE:** NA

**QUANTITY:**

<b>Code</b>	<b>A-093</b>	<b>Quantity</b>
Room_Number		
C118		1
SUB TOTAL		1

**IMAGE:**



**CODE** A-094  
**ITEM:** Steel Blade  
**MANUFACTURER:** Dexter  
**MODEL:** A12R  
**FINISHES:** Steel

**DIMENSIONS:** 12" L

**DESCRIPTION:** Steel features a stain free blade in either high carbon steel or classic high carbon steel blade with an individually ground and honed edge. &nbsp;Handle is secure to the blade with brass compression rivets.

**KNEE CLEARANCE:** NA

**QUANTITY:**

<b>Code</b>	<b>A-094</b>	<b>Quantity</b>
Room_Number		
C118		1
SUB TOTAL		1

**IMAGE:**





**CODE** A-095  
**ITEM:** Steam Table Pan 1  
**MANUFACTURER:** Vollrath  
**MODEL:** 3002-2  
**FINISHES:** Stainless Steel  
  
**DIMENSIONS:** 12-3/4" x 20-3/4" x 2-1/2"  
**DESCRIPTION:** Heavy Duty 20 Gauge 300 series stainless steel, reinforced corner for extra durability, anti jamming design, flat edge and corners keep pans tight in well.

**KNEE CLEARANCE:** NA

**QUANTITY:**

Code	A-095	Quantity
Room_Number		
C118		12
SUB TOTAL		12

**IMAGE:**



**CODE** A-096  
**ITEM:** Steam Table Pan 2  
**MANUFACTURER:** Vollrath  
**MODEL:** 3004-2  
**FINISHES:** Stainless Steel

**DIMENSIONS:** 12-3/4" x 20-3/4" x 4"

**DESCRIPTION:** Heavy Duty 20 Gauge 300 series stainless steel, reinforced corner for extra durability, anti jamming design, flat edge and corners keep pans tight in well.

**KNEE CLEARANCE:** NA

**QUANTITY:**

<b>Code</b>	<b>A-096</b>	<b>Quantity</b>
Room_Number		
C118		12
SUB TOTAL		12

**IMAGE:**



**CODE** A-097  
**ITEM:** Steam Table Pan 3  
**MANUFACTURER:** Vollrath  
**MODEL:** 3006-2  
**FINISHES:** Stainless Steel

**DIMENSIONS:** 12-3/4" x 20-3/4" x 6"

**DESCRIPTION:** Heavy Duty 20 Gauge 300 series stainless steel, reinforced corner for extra durability, anti jamming design, flat edge and corners keep pans tight in well.

**KNEE CLEARANCE:** NA

**QUANTITY:**

<b>Code</b>	<b>A-097</b>	<b>Quantity</b>
Room_Number		
C118		6
SUB TOTAL		6

**IMAGE:**



**CODE** A-098  
**ITEM:** Steam Table Pan 4  
**MANUFACTURER:** Vollrath  
**MODEL:** 3004-3  
**FINISHES:** Perforated

**DIMENSIONS:** 12-3/4" x 20" x 4"

**DESCRIPTION:** Heavy Duty 20 Gauge 300 series stainless steel, reinforced corner for extra durability, anti jamming design, flat edge and corners keep pans tight in well.

**KNEE CLEARANCE:** NA

**QUANTITY:**

Code	A-098	Quantity
Room_Number		
C118		4
SUB TOTAL		4

**IMAGE:**



**CODE** A-099  
**ITEM:** Steam Table Pan 5  
**MANUFACTURER:** Vollrath  
**MODEL:** 3002-3  
**FINISHES:** Perforated

**DIMENSIONS:** 12-3/4" x 20" x 2-1/2"

**DESCRIPTION:** Heavy Duty 20 Gauge 300 series stainless steel, reinforced corner for extra durability, anti jamming design, flat edge and corners keep pans tight in well.

**KNEE CLEARANCE:** NA

**QUANTITY:**

<b>Code</b>	<b>A-099</b>	<b>Quantity</b>
Room_Number		
C118		3
SUB TOTAL		3

**IMAGE:**



**CODE** A-100  
**ITEM:** Steam Table Pan Cover 1  
**MANUFACTURER:** Vollrath  
**MODEL:** 77250  
**FINISHES:** Stainless Steel

**DIMENSIONS:** 12-3/4" x 20"

**DESCRIPTION:** Covers with reinforced edge stay flat for longer and fit securely to help prevent spills during transport. Reinforced edges add strength to the perimeter of the cover, 18-8 stainless steel.

**KNEE CLEARANCE:** NA

**QUANTITY:**

Code	A-100	Quantity
Room_Number		
C118		6
SUB TOTAL		6

**IMAGE:**



**CODE** A-101  
**ITEM:** Steam Table Pan Cover 2  
**MANUFACTURER:** Vollrath  
**MODEL:** 77510  
**FINISHES:** Flat slotted Stainless Steel

**DIMENSIONS:** 12-3/4" x 20"

**DESCRIPTION:** Covers with reinforced edge stay flat for longer and fit securely to help prevent spills during transport. Reinforced edges add strength to the perimeter of the cover, 18-8 stainless steel.

**KNEE CLEARANCE:** NA

**QUANTITY:**

Code	A-101	Quantity
Room_Number		
C118		6
SUB TOTAL		6

**IMAGE:**



**CODE** A-102  
**ITEM:** Steam Table Pan 6  
**MANUFACTURER:** Vollrath  
**MODEL:** 3024-2  
**FINISHES:** Stainless Steel

**DIMENSIONS:** 10-3/8" x 12-3/4" x 4"

**DESCRIPTION:** Heavy duty 20 guage 300 series stainless steel with reinforced edges for extra durability, anti jamming design, and flat edge and corners keep pans tight and in well.

**KNEE CLEARANCE:** NA

**QUANTITY:**

Code	A-102	Quantity
Room_Number		
C118		6
SUB TOTAL		6

**IMAGE:**





**CODE** A-103  
**ITEM:** Steam Table Pan 7  
**MANUFACTURER:** Vollrath  
**MODEL:** 3026-2  
**FINISHES:** Stainless Steel

**DIMENSIONS:** 10-3/8" x 12-3/4" x 6"

**DESCRIPTION:** Heavy duty 20 guage 300 series stainless steel with reinforced edges for extra durability, anti jamming design, and flat edge and corners keep pans tight and in well.

**KNEE CLEARANCE:** NA

**QUANTITY:**

Code	A-103	Quantity
Room_Number		
C118		3
SUB TOTAL		3

**IMAGE:**



**CODE** A-104  
**ITEM:** Steam Table Pan Cover 3  
**MANUFACTURER:** Vollrath  
**MODEL:** 75120  
**FINISHES:** Flat solid Stainless Steel

**DIMENSIONS:** 10-3/8" x 12-3/4"

**DESCRIPTION:** Covers with reinforced edge stay flat for longer and fit securely to help prevent spills during transport. Reinforced edges add strength to the perimeter of the cover, 18-8 stainless steel.

**KNEE CLEARANCE:** NA

**QUANTITY:**

Code	A-104	Quantity
Room_Number		
C118		6
SUB TOTAL		6

**IMAGE:**



**CODE** A-105  
**ITEM:** Stream Table Pan 8  
**MANUFACTURER:** Vollrath  
**MODEL:** 3034-2  
**FINISHES:** Stainless Steel

**DIMENSIONS:** 6 -7/8" x 12 -3/4" x 4"

**DESCRIPTION:** Heavy duty 20 guage 300 series stainless steel with reinforced edges for extra durability, anti jamming design, and flat edge and corners keep pans tight and in well.

**KNEE CLEARANCE:** NA

**QUANTITY:**

Code	A-105	Quantity
Room_Number		
C118		2
SUB TOTAL		2

**IMAGE:**



**CODE** A-106  
**ITEM:** Steam Table Pan 9  
**MANUFACTURER:** Vollrath  
**MODEL:** 3036-2  
**FINISHES:** Stainless Steel

**DIMENSIONS:** 6-7/8" x 12-3/4" x 6"

**DESCRIPTION:** Heavy duty 20 guage 300 series stainless steel with reinforced edges for extra durability, anti jamming design, and flat edge and corners keep pans tight and in well.

**KNEE CLEARANCE:** NA

**QUANTITY:**

Code	A-106	Quantity
Room_Number		
C118		2
SUB TOTAL		2

**IMAGE:**



**CODE:** A-107  
**ITEM:** Steam Table Pan Cover 4  
**MANUFACTURER:** Vollrath  
**MODEL:** 75130  
**FINISHES:** Stainless Steel

**DIMENSIONS:** 6-7/8" x 12-3/4"

**DESCRIPTION:** Covers with reinforced edge stay flat for longer and fit securely to help prevent spills during transport. Reinforced edges add strength to the perimeter of the cover, 18-8 stainless steel.

**KNEE CLEARANCE:** NA

**QUANTITY:**

Code	A-107	Quantity
Room_Number		
C118		4
SUB TOTAL		4

**IMAGE:**



**CODE** A-108  
**ITEM:** Steam Table Pan 10  
**MANUFACTURER:** Vollrath  
**MODEL:** 3064-2  
**FINISHES:** Stainless Steel

**DIMENSIONS:** 6-7/8" x 6-1/4" x 4"

**DESCRIPTION:** Heavy duty 20 guage 300 series stainless steel with reinforced edges for extra durability, anti jamming design, and flat edge and corners keep pans tight and in well.

**KNEE CLEARANCE:** NA

**QUANTITY:**

<b>Code</b>	<b>A-108</b>	<b>Quantity</b>
Room_Number		
C118		10
SUB TOTAL		10

**IMAGE:**



**CODE** A-109  
**ITEM:** Tongs 1  
**MANUFACTURER:** Vollrath  
**MODEL:** 47309  
**FINISHES:** Stainless Steel  
  
**DIMENSIONS:** 9-1/2"L  
**DESCRIPTION:** Heavy Duty Tongs are constructed of 20 gauge stainless steel.<br>
 Economy tongs are constructed of 24 gauge stainless steel.

**KNEE CLEARANCE:** NA

**QUANTITY:**

Code	A-109	Quantity
Room_Number		
C118		6
SUB TOTAL		6

**IMAGE:**



**CODE** A-110  
**ITEM:** Tongs 2  
**MANUFACTURER:** Vollrath  
**MODEL:** 47312  
**FINISHES:** Stainless Steel  
  
**DIMENSIONS:** 12"L  
**DESCRIPTION:** Heavy Duty Tongs are constructed of 20 gauge stainless steel.<br>
 Economy tongs are constructed of 24 gauge stainless steel.

**KNEE CLEARANCE:** NA

**QUANTITY:**

<b>Code</b>	<b>A-110</b>	<b>Quantity</b>
Room_Number		
C118		3
SUB TOTAL		3

**IMAGE:**





**CODE** A-111  
**ITEM:** Piano Whips 1  
**MANUFACTURER:** Vollrath  
**MODEL:** 47032  
**FINISHES:** Stainless Steel

**DIMENSIONS:** 12"L

**DESCRIPTION:** Integral nubs for sure grip , Fine wires for mixing or aerating thinner food products , Wires are constructed from stainless steel to resist corrosion and rusting , One-piece stainless steel handle , Center reinforcement wire eliminates bending, twisting, and deforming.

**KNEE CLEARANCE:** NA

**QUANTITY:**

<b>Code</b>	<b>A-111</b>	<b>Quantity</b>
Room_Number		
C118		2
SUB TOTAL		2

**IMAGE:**



**CODE** A-112  
**ITEM:** Piano Whips 2  
**MANUFACTURER:** Vollrath  
**MODEL:** 47036  
**FINISHES:** Stainless Steel

**DIMENSIONS:** 16"L

**DESCRIPTION:** Integral nubs for sure grip , Fine wires for mixing or aerating thinner food products , Wires are constructed from stainless steel to resist corrosion and rusting , One-piece stainless steel handle , Center reinforcement wire eliminates bending, twisting, and deforming.

**KNEE CLEARANCE:** NA

**QUANTITY:**

Code	A-112	Quantity
Room_Number		
C118		2
SUB TOTAL		2

**IMAGE:**



**CODE** A-113  
**ITEM:** Mixing Bowl 1  
**MANUFACTURER:** Vollrath  
**MODEL:** 69130  
**FINISHES:** Stainless Steel

**DIMENSIONS:** 13 qt capacity/ 16" Diameter

**DESCRIPTION:** Constructed of 300 Series Stainless Steel, Precise capacities , Concave bottoms sit flat on countertop , Consistent size and dimensions make nested storage easy . Satin finish interior , Stain and scratch resistant ,Proper weighting prevents tipping when in use , Made in the USA , \* 30, 45 and 80 quart bowls are NSF Certified , 79800 80 quart bowl has round bottom.

**KNEE CLEARANCE:** NA

**QUANTITY:**

Code	A-113	Quantity
Room_Number		
C118		2
SUB TOTAL		2

**IMAGE:**



**CODE** A-114  
**ITEM:** Mixing bowl 2  
**MANUFACTURER:** Vollrath  
**MODEL:** 69080  
**FINISHES:** Stainless Steel

**DIMENSIONS:** 8 qt capacity / 13 1/4" Diameter

**DESCRIPTION:** Constructed of 300 Series Stainless Steel, Precise capacities , Concave bottoms sit flat on countertop , Consistent size and dimensions make nested storage easy . Satin finish interior , Stain and scratch resistant ,Proper weighting prevents tipping when in use , Made in the USA , \* 30, 45 and 80 quart bowls are NSF Certified , 79800 80 quart bowl has round bottom.

**KNEE CLEARANCE:** NA

**QUANTITY:**

Code	A-114	Quantity
Room_Number		
C118		2
SUB TOTAL		2

**IMAGE:**



**CODE** A-115  
**ITEM:** Colander  
**MANUFACTURER:** Vollrath  
**MODEL:** 68350  
**FINISHES:** Aluminum

**DIMENSIONS:** 16 qt capacity

**DESCRIPTION:** Heavy-gauge impact-resistant 3004 aluminum , Full ring welded base for added stability , Thick rim and walls resist denting , Strong riveted handles make transport easy.

**KNEE CLEARANCE:** NA

**QUANTITY:**

<b>Code</b>	<b>A-115</b>	<b>Quantity</b>
Room_Number		
C118		2
SUB TOTAL		2

**IMAGE:**



**CODE** A-116  
**ITEM:** Sauce Pan 1  
**MANUFACTURER:** Vollrath-Arkadia  
**MODEL:** 7344  
**FINISHES:** Aluminum  
  
**DIMENSIONS:** 9" Inside Diameter, 4 1/2 qt capacity  
**DESCRIPTION:** Natural finish sauce pans constructed of heavy gauge aluminum.

**KNEE CLEARANCE:** NA

**QUANTITY:**

Code	A-116	Quantity
Room_Number		
C118		2
SUB TOTAL		2

**IMAGE:**



**CODE** A-117  
**ITEM:** Sauce Pan 2  
**MANUFACTURER:** Wear-Ever  
**MODEL:** 4348 1/2  
**FINISHES:** Aluminum  
  
**DIMENSIONS:** 11-5/16" Inside Diameter, 8 1/2 qt capacity  
**DESCRIPTION:** Natural finish sauce pans constructed of heavy gauge aluminum.

**KNEE CLEARANCE:** NA

**QUANTITY:**

Code	A-117	Quantity
Room_Number		
C118		2
SUB TOTAL		2

**IMAGE:**



**CODE** A-118  
**ITEM:** Sheet Pans  
**MANUFACTURER:** Vollrath  
**MODEL:** 68386  
**FINISHES:** Aluminum

**DIMENSIONS:** 17 3/4" x 25 3/4" x 1"

**DESCRIPTION:** Coated with SteelCoat x3 for easy food release and cleaning, Impact resistant 3004 aluminum , Tapered design for easy stacking , Sized to fit standard baker's rack , Closed bead includes galvanized non-rusting rod for reinforcements , Concave bottoms flatten during heating for even heat distribution , 68386 is NSF Certified.

**KNEE CLEARANCE:** NA

**QUANTITY:**

Code	A-118	Quantity
Room_Number		
C118		36
SUB TOTAL		36

**IMAGE:**





**CODE** A-119  
**ITEM:** Cutting Boards  
**MANUFACTURER:** Vollrath  
**MODEL:** 5200340, 5200300, 5200350, 5200370  
**FINISHES:** Hard Plastic  
  
**DIMENSIONS:** 18" x 24" x 1/2"  
**DESCRIPTION:** Cutting Boards-Provide (1) 5200340-Red, (1) 5200300-White, (1) 5200350-Yellow, (1) 5200370-Green<br>
 <br>
 High-density non-porous surface will not stain or absorb juices , Color-coded system reduces risk of foodborne illness resulting from cross-contamination , Ideal system for maximizing HACCP program , 1/2" (1.3 cm) thick.

**KNEE CLEARANCE:** NA

**QUANTITY:**

Code	A-119	
Room_Number		Quantity
C101		1
C118		4
SUB TOTAL		5

**IMAGE:**



**CODE** A-120  
**ITEM:** Electric Can Opener  
**MANUFACTURER:** Superior Specialty Co.  
**MODEL:** 270  
**FINISHES:** Stainless Steel  
  
**DIMENSIONS:** 6-3/4" x 11-1/2" x 10"  
**DESCRIPTION:** Electric Can Opener Counter model, removable knife and gear, 2 speed motor, NSF Certified.

**KNEE CLEARANCE:** NA

**QUANTITY:**

Code	A-120	Quantity
Room_Number		
C118		1
SUB TOTAL		1

**IMAGE:**



**CODE** A-121  
**ITEM:** Thermometers  
**MANUFACTURER:** Calico Industries-Comark Instruments  
**MODEL:** 27RFT2A  
**FINISHES:** Glass

**DIMENSIONS:** 2.15"L x 5.2"W x 2.9"H

**DESCRIPTION:** This thermometer hangs or stands with easy-to-read bold numbers. Blue and green zones indicate safe temperature while red indicates possible spoilage. Ranges from -20 degrees F- 80 degrees F

**KNEE CLEARANCE:** NA

**QUANTITY:**

Code	A-121	Quantity
Room_Number		
C118		8
SUB TOTAL		8

**IMAGE:**



**CODE** A-122  
**ITEM:** Disher 5  
**MANUFACTURER:** Vollrath  
**MODEL:** 47140  
**FINISHES:** Grey

**DIMENSIONS:** 9- 9/16"L, Size 8

**DESCRIPTION:** Molded one-piece handle made with agion improves durability, makes cleaning easy and prevents handle from coming apart, Stainless steel bowl and components to prevent corrosion and insure longer life, Color-coded handle for no-guess size selection, Extended grooved handle provides a sure grip for comfortable use, Blade extends beyond bowl to prevent sticking, Accurate portions, Dishwasher safe, USA made - NSF Certified, Limited lifetime warranty, Replacement spring available, Item 23612-1057.

**KNEE CLEARANCE:** NA

**QUANTITY:**

Code	A-122	Quantity
Room_Number		
C118		2
SUB TOTAL		2

**IMAGE:**



**CODE** A-123  
**ITEM:** Ladle 4  
**MANUFACTURER:** Vollrath  
**MODEL:** 58440  
**FINISHES:** Stainless Steel

**DIMENSIONS:** 12 -5/8"L, 4 oz. capacity

**DESCRIPTION:** Ladle has attractive bright finish, hooked handle to prevent sliding and easy storage, grooved handle for extra strength.

**KNEE CLEARANCE:** NA

**QUANTITY:**

<b>Code</b>	<b>A-123</b>	<b>Quantity</b>
Room_Number		
C118		2
SUB TOTAL		2

**IMAGE:**



**CODE** A-124  
**ITEM:** Basting Brush  
**MANUFACTURER:** Vollrath  
**MODEL:** 458  
**FINISHES:** Boar Bristles with Wood handle  
  
**DIMENSIONS:** 1 -1/2" Brush Width, 8- 1/4"L  
**DESCRIPTION:** Basting Brush made with Boar's hair bristles and a wooden handle.

**KNEE CLEARANCE:** NA

**QUANTITY:**

Code	A-124	Quantity
Room_Number		
C118		3
SUB TOTAL		3

**IMAGE:**



**CODE** A-125  
**ITEM:** Rubber Spatulas  
**MANUFACTURER:** Vollrath  
**MODEL:** 52023  
**FINISHES:** Nylon handle, Silicone blade

**DIMENSIONS:** 13-1/2"L

**DESCRIPTION:** Rubber Spatulas offers a unique contoured handle that hangs easily, dish washer safe, heat resistant to 500 degrees. Molded together to form sanitary seal, non-scratch blade is stain and odor resistant.

**KNEE CLEARANCE:** NA

**QUANTITY:**

Code	A-125	Quantity
Room_Number		
C118		3
SUB TOTAL		3

**IMAGE:**



**CODE** A-126  
**ITEM:** Pizza Cutters  
**MANUFACTURER:** Dexter  
**MODEL:** P94ZZA-4  
**FINISHES:** Black

**DIMENSIONS:** 4" diameter blade

**DESCRIPTION:** Pizza Cutter features a stain-free, high-carbon steel blade with durable, slip-resistant polypropylene handle. Items marked with the NSF logo are NSF Certified.

**KNEE CLEARANCE:** NA

**QUANTITY:**

Code	A-126	Quantity
Room_Number		
C118		4
SUB TOTAL		4

**IMAGE:**





**CODE** A-127  
**ITEM:** Tongs 3  
**MANUFACTURER:** Royal Industries  
**MODEL:** ROY PCT 9  
**FINISHES:** Black Plastic

**DIMENSIONS:** 9"

**DESCRIPTION:** Versatile and economical, multi-purpose tongs can be used for any number of tasks in a professional kitchen. The tongs are perfect for the front of house because they can be used for anything from grabbing items on buffets to adding toppings to salads. The 9" plastic multi-purpose tongs from Royal Industries are perfect for buffet lines, as they are able to handle a number of tasks and are easy to clean. They come in a set of 12.

**KNEE CLEARANCE:** NA

**QUANTITY:**

Code	A-127	Quantity
Room_Number		
C118		12
SUB TOTAL		12

**IMAGE:**



**CODE** A-128  
**ITEM:** Pocket Thermometers  
**MANUFACTURER:** Calico Industries - Taylor Precision Products  
**MODEL:** 2760921  
**FINISHES:** Stainless Steel  
  
**DIMENSIONS:** 5" long stem  
**DESCRIPTION:** Pocket thermometer has high visibilty dial graphics, stem is constructed of durable stainless steel with a shatterproof plastic lens. Ranges from 0 degrees F-220 degrees F, NSF Certified. One point calibration and a lifetime warranty.

**KNEE CLEARANCE:** NA

**QUANTITY:**

Code	A-128	Quantity
Room_Number		
C118		4
SUB TOTAL		4

**IMAGE:**



**CODE** A-129  
**ITEM:** Grated Cheese Shakers  
**MANUFACTURER:** Vollrath  
**MODEL:** 674  
**FINISHES:** Stainless Steel and Glass  
  
**DIMENSIONS:** 3 -5/8"H x 2 -1/2" Diameter, 6 oz. capacity  
**DESCRIPTION:** Grated Cheese Shakers have a stainless steel perforated top and a swirled glass jar design.

**KNEE CLEARANCE:** NA

**QUANTITY:**

Code	A-129	Quantity
Room_Number		
C118		6
SUB TOTAL		6

**IMAGE:**



**CODE** A-130  
**ITEM:** Condiment Containers/ Squeeze Bottles  
**MANUFACTURER:** Vollrath  
**MODEL:** 62061 & 52062  
**FINISHES:** Red Bottle- 62061 and YellowBottle-62062 Polyethylene  
  
**DIMENSIONS:** 7- 1/4"H x 2" Diameter, 8 oz. capacity  
**DESCRIPTION:** Condiment Containers have a no grip design &nbsp;that helps to prevent table and counter messes, made of low density polyethylene.

**KNEE CLEARANCE:** NA

**QUANTITY:**

Code	A-130	Quantity
Room_Number		
C118		12
SUB TOTAL		12

**IMAGE:**



**CODE** A-131  
**ITEM:** Saddle Bag Dispensers  
**MANUFACTURER:** Hubert  
**MODEL:** 63496  
**FINISHES:** NA

**DIMENSIONS:** 10.45"W x 13.05"L x 6.35"H

**DESCRIPTION:** LDPE bags are more durable and easy to close with a re-locking zipper. Graphics feature "Fresh" in five languages for broad appeal. 10 x 8. 1000 per case. Made from heavy 1.25 mil construction.

**KNEE CLEARANCE:** NA

**QUANTITY:**

Code	A-131	Quantity
Room_Number		
C118		4
SUB TOTAL		4

**IMAGE:**



**CODE** A-132  
**ITEM:** Can Rack  
**MANUFACTURER:** Calico Industries  
**MODEL:** 57CSR9  
**FINISHES:** Aluminum

**DIMENSIONS:** 76"H x 25 1/2"W x 35"D

**DESCRIPTION:** Inclined can glides provide easy access & facilitate stock rotation when loaded from rear. All heli-arc welded aluminum construction. Available to meet all corrections specifications.

**KNEE CLEARANCE:** NA

**QUANTITY:**

Code	A-132	Quantity
Room_Number		
C118		1
SUB TOTAL		1

**IMAGE:**



**CODE** A-133  
**ITEM:** Utility Carts  
**MANUFACTURER:** RubberMaid  
**MODEL:** 4091  
**FINISHES:** Black Polyethylene  
  
**DIMENSIONS:** 37.8"H x 40-5/8"L x 20"W  
**DESCRIPTION:** Open sided Utility Cart has a 300lb mass capacity (100lbs per shelf), sized to carry large loads of various equipment. Constructed of High Density Polyethylene.

**KNEE CLEARANCE:** NA

**QUANTITY:**

Code	A-133	Quantity
Room_Number		
C118		2
SUB TOTAL		2

**IMAGE:**



**CODE** A-134  
**ITEM:** Open Sided Sheet Pan Rack  
**MANUFACTURER:** KaTom Restaurant Supplies Inc. - Doyon Baking Equipment  
**MODEL:** 013-1811SL  
**FINISHES:** Aluminum

**DIMENSIONS:** 68.125in. H x 20.375in. W x 26in. D.

**DESCRIPTION:** Pan Rack, full height, open sides, side loading, (11) aluminum angle slides on 5" centers, for 18" x 26" sheet pans, knock down aluminum frame, 5" heavy duty casters.

**KNEE CLEARANCE:** NA

**QUANTITY:**

Code	A-134	Quantity
Room_Number		
C118		3
SUB TOTAL		3

**IMAGE:**





**CODE** A-135  
**ITEM:** Portion Server 1  
**MANUFACTURER:** Vollrath  
**MODEL:** 6412445  
**FINISHES:** Grey, Solid

**DIMENSIONS:** 13-13/16"L, 4 oz. capacity

**DESCRIPTION:** Portion Server is one piece construction made durable and sanitary, unique oval bowl designs fits into corners for minimum waste, color coded for quick identification, textured handle surface prevents grip slippage. Nylon handle is heat resistant to 450 degrees F, stainless steel material is resistant to corrosion, built in stopper notch prevents spoon from sliding into food product. Ergonomic design reduces hand fatigue.

**KNEE CLEARANCE:** NA

**QUANTITY:**

Code	A-135	Quantity
Room_Number		
C118		4
SUB TOTAL		4

**IMAGE:**



**CODE** A-136  
**ITEM:** Portion Server 2  
**MANUFACTURER:** Vollrath  
**MODEL:** 6422445  
**FINISHES:** Grey, Perforated

**DIMENSIONS:** 13-13/16"L, 4 oz.capacity

**DESCRIPTION:** Portion Server is one piece construction made durable and sanitary, unique oval bowl designs fits into corners for minimum waste, color coded for quick identification, textured handle surface prevents grip slippage. Nylon handle is heat resistant to 450 degrees F, stainless steel material is resistant to corrosion, built in stopper notch prevents spoon from sliding into food product. Ergonomic design reduces hand fatigue.

**KNEE CLEARANCE:** NA

**QUANTITY:**

Code	A-136	Quantity
Room_Number		
C118		4
SUB TOTAL		4

**IMAGE:**



**CODE** A-137  
**ITEM:** Portion Server 3  
**MANUFACTURER:** Vollrath  
**MODEL:** 6412655  
**FINISHES:** Teal, Solid

**DIMENSIONS:** 14-3/8"L, 6 oz. capacity

**DESCRIPTION:** Portion Server is one piece construction made durable and sanitary, unique oval bowl designs fits into corners for minimum waste, color coded for quick identification, textured handle surface prevents grip slippage. Nylon handle is heat resistant to 450 degrees F, stainless steel material is resistant to corrosion, built in stopper notch prevents spoon from sliding into food product. Ergonomic design reduces hand fatigue.

**KNEE CLEARANCE:** NA

**QUANTITY:**

Code	A-137	Quantity
Room_Number		
C118		4
SUB TOTAL		4

**IMAGE:**



**CODE** A-138  
**ITEM:** Portion Server 4  
**MANUFACTURER:** Vollrath  
**MODEL:** 6422655  
**FINISHES:** Perforated

**DIMENSIONS:** 14-3/8"L, 6 oz. capacity

**DESCRIPTION:** Portion Server is one piece construction made durable and sanitary, unique oval bowl designs fits into corners for minimum waste, color coded for quick identification, textured handle surface prevents grip slippage. Nylon handle is heat resistant to 450 degrees F, stainless steel material is resistant to corrosion, built in stopper notch prevents spoon from sliding into food product. Ergonomic design reduces hand fatigue.

**KNEE CLEARANCE:** NA

**QUANTITY:**

Code	A-138	Quantity
Room_Number		
C118		4
SUB TOTAL		4

**IMAGE:**



**CODE** A-139  
**ITEM:** Portion Server 5  
**MANUFACTURER:** Vollrath  
**MODEL:** 6412865  
**FINISHES:** Orange, Solid

**DIMENSIONS:** 14-3/4"L, 8 oz. capacity

**DESCRIPTION:** Portion Server is one piece construction made durable and sanitary, unique oval bowl designs fits into corners for minimum waste, color coded for quick identification, textured handle surface prevents grip slippage. Nylon handle is heat resistant to 450 degrees F, stainless steel material is resistant to corrosion, built in stopper notch prevents spoon from sliding into food product. Ergonomic design reduces hand fatigue.

**KNEE CLEARANCE:** NA

**QUANTITY:**

Code	A-139	Quantity
Room_Number		
C118		4
SUB TOTAL		4

**IMAGE:**



**CODE** A-140  
**ITEM:** Portion Server 6  
**MANUFACTURER:** Vollrath  
**MODEL:** 6422865  
**FINISHES:** Orange, Perforated

**DIMENSIONS:** 14-3/4"L, 8 oz. capacity

**DESCRIPTION:** Portion Server is one piece construction made durable and sanitary, unique oval bowl designs fits into corners for minimum waste, color coded for quick identification, textured handle surface prevents grip slippage. Nylon handle is heat resistant to 450 degrees F, stainless steel material is resistant to corrosion, built in stopper notch prevents spoon from sliding into food product. Ergonomic design reduces hand fatigue.

**KNEE CLEARANCE:** NA

**QUANTITY:**

Code	A-140	Quantity
Room_Number		
C118		4
SUB TOTAL		4

**IMAGE:**



**CODE** A-141  
**ITEM:** Calendar White Board  
**MANUFACTURER:** MagnaLite  
**MODEL:** Monthly Planning Kit  
**FINISHES:** White Board

**DIMENSIONS:** 4' x 3'

**DESCRIPTION:** <div>Plan your month in detail with Magna Visual's Monthly Planning Kit. The gray porcelain surface and gray frame provide a contemporary look to complement your office décor. Use the magnetic month and date headings to customize the monthly calendar. Write notes about important meetings and projects directly on the dry erase surface, or use the water-soluble marker (included) to write on the magnetic strips for fast adjusting of information. <strong>ITEM MUST BE INSTALLED BY VENDOR.</strong></div>

**KNEE CLEARANCE:** NA

**QUANTITY:**

Code	A-141	Quantity
Room_Number		
B133		1
SUB TOTAL		1

**IMAGE:**



**CODE** A-142  
**ITEM:** Foot Stool with Handle  
**MANUFACTURER:** School Health  
**MODEL:** 24307  
**FINISHES:** Black  
  
**DIMENSIONS:** 34" H  
**DESCRIPTION:** Foam coated handrail, with widespread legs for stability and the platform has a non-slip texture mat for your feet.

**KNEE CLEARANCE:** NA

**QUANTITY:**

Code	A-142	Quantity
Room_Number		
B140		1
SUB TOTAL		1

**IMAGE:**





**CODE** A-143  
**ITEM:** White Board  
**MANUFACTURER:** Best-Rite  
**MODEL:** ABC Magnetic Marker Board  
**FINISHES:** White Porcelian

**DIMENSIONS:** 6'x 4'

**DESCRIPTION:** <div>Best-Rite's ABC Magnetic Markerboard is an affordable addition to your classroom. This porcelain-on-steel dry erase board accepts magnets, so you can easily hang classroom assignments, visual aids and art projects. The low-gloss writing surface offers a greater contrast for markers, resists ghosting and carries a 50-year guarantee. An aluminum tray keeps writing supplies close at hand and features protective end caps that help prevent classroom injuries. All Best-Rite ABC Magnetic Markerboards come with a free set of dry erase markers. <strong>ITEM MUST BE INSTALLED BY VENDOR.</strong></div>

**KNEE CLEARANCE:** NA

**QUANTITY:**

Code	A-143	Quantity
Room_Number		
B140		1
SUB TOTAL		1

**IMAGE:**



**CODE** A-144  
**ITEM:** Large Paper Cutter  
**MANUFACTURER:** School Specialty- Quartet  
**MODEL:** 032703  
**FINISHES:** Composition board  
  
**DIMENSIONS:** 30"L x 30"W  
**DESCRIPTION:** 30" Quartet Swingline ClassicCut Ingento Paper Cutter has hardwood veneer alignment guides, carbon spring blade that can cut up to 15 sheets of paper. Includes finger guard and handle lock, grid is scored on 1/2", 10 yr Warranty.

**KNEE CLEARANCE:** NA

**QUANTITY:**

Code	A-144	Quantity
Room_Number		
B126		1
SUB TOTAL		1

**IMAGE:**



**CODE** A-145  
**ITEM:** Large Book Baskets  
**MANUFACTURER:** Sterilite  
**MODEL:** 084321  
**FINISHES:** White

**DIMENSIONS:** 15 7/8" x 12 7/8" x 6"H

**DESCRIPTION:** By Sterilite Corp. Stacking Baskets have an innovative design that allows them to stack during use but nest when not in use. The ventilated sides help keep clutter contained but still allow for identification of stored items. Ideal for organizing countertops or closet shelves. All units feature integrated handles for easy carrying.

**KNEE CLEARANCE:** N/A

**QUANTITY:**

Code	A-145	Quantity
Room_Number		
A101		12
A106		12
A107		12
A113		12
A118		12
A119		12
A122		12
A130		12
B134		12
B138		12
A201		12
A202		12
A203		12
A204		12
A205		12
A206		12
A207		12
A208		12
A214		12
A215		12
B201		12
B202		12
B204		12
B205		12
A112		12
<b>SUB TOTAL</b>		<b>300</b>

IMAGE:



**CODE** A-146  
**ITEM:** Medium Book Basket  
**MANUFACTURER:** Sterilite  
**MODEL:** 084320  
**FINISHES:** White

**DIMENSIONS:** 13 3/4" x 10 3/4" x 5"H

**DESCRIPTION:** By Sterilite Corp. Stacking Baskets have an innovative design that allows them to stack during use but nest when not in use. The ventilated sides help keep clutter contained but still allow for identification of stored items. Ideal for organizing countertops or closet shelves. All units feature integrated handles for easy carrying.

**KNEE CLEARANCE:** N/A

**QUANTITY:**

Code	A-146	Quantity
Room_Number		
A101		12
A106		12
A107		12
A113		12
A118		12
A119		12
A130		12
B134		12
B138		12
A201		12
A202		12
A203		12
A204		12
A205		12
A206		12
A207		12
A208		12
A214		12
A215		12
B201		12
B202		12
B204		12
B205		12
A112		12
SUB TOTAL		288

IMAGE:



**CODE** A-147  
**ITEM:** Sheet Pans for Camcart  
**MANUFACTURER:** Advance Tabco  
**MODEL:** 18A26  
**FINISHES:** 16 Gage Alluminum  
  
**DIMENSIONS:** 18" x 26"  
**DESCRIPTION:** Confirm Size Fits in Camcart (E-144)

**KNEE CLEARANCE:** NA

**QUANTITY:**

<b>Code</b>	<b>A-147</b>	<b>Quantity</b>
Room_Number		
C118		48
SUB TOTAL		48

**IMAGE:**



**CODE** CH-001  
**ITEM:** Pre K Chairs Xtra Small  
**MANUFACTURER:** KI  
**MODEL:** IW410  
**FINISHES:** Polypropylene in Splash, glides for carpet use

**DIMENSIONS:** 20"H x 14.8"W x 14"D, Seat height- 10"H

**DESCRIPTION:** Intellect Wave 4 leg chair has a unique shell, designed with proper curves to help support functionality and ergonomics in the classroom. You can choose from an extensive selection of colors and finishes, available in poly shell, upholstered seat, or upholstered seat and back. A book rack is also available.

**KNEE CLEARANCE:** NA

**QUANTITY:**

Code	CH-001	Quantity
Room_Number		
A106		35
A107		35
A118		35
SUB TOTAL		105

**IMAGE:**





**CODE** CH-002  
**ITEM:** K + 1st Grade Small Chairs  
**MANUFACTURER:** KI  
**MODEL:** IWC13  
**FINISHES:** Polypropylene in Splash, glides for carpet use

**DIMENSIONS:** 23"H x 15.4"W x 14.2"D, Seat height- 13.7"H

**DESCRIPTION:** Intellect Wave Cantilever chair easily stacks on desk, it's unique shell design has all the proper curves to support functionality and ergonomics in the classroom. Choose from an extensive selection of colors and finishes. Available as a poly shell, upholstered seat, or upholstered seat and back and book rack also available.

**KNEE CLEARANCE:** NA

**QUANTITY:**

Code	CH-002	Quantity
Room_Number		
A101		35
A112		35
A113		35
A119		35
A122		18
A130		35
B107A		4
B134		14
B138		35
<b>SUB TOTAL</b>		<b>246</b>

**IMAGE:**



**CODE** CH-003  
**ITEM:** 2nd + 3rd Grade Medium Chairs  
**MANUFACTURER:** KI  
**MODEL:** IWC15  
**FINISHES:** Polypropylene in Splash, glides for carpet use

**DIMENSIONS:** 26.5"H x 17.2"W x 16.2"D, Seat height- 15"H

**DESCRIPTION:** Intellect Wave Cantilever chair easily stacks on desk, it's unique shell design has all the proper curves to support functionality and ergonomics in the classroom. Choose from an extensive selection of colors and finishes. Available as a poly shell, upholstered seat, or upholstered seat and back and book rack also available.

**KNEE CLEARANCE:** NA

**QUANTITY:**

Code	CH-003	
Room_Number		Quantity
A208		14
A214		35
A215		35
B201		35
B202		35
B204		35
B205		35
SUB TOTAL		224

**IMAGE:**

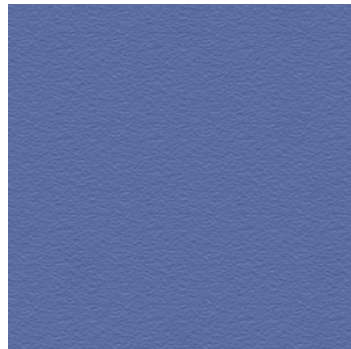

**CODE** CH-004  
**ITEM:** 4 th + 5th Grade Large Chairs  
**MANUFACTURER:** KI  
**MODEL:** IWC18  
**FINISHES:** Polypropylene in Splash, glides for carpet use

**DIMENSIONS:** 32"H x 20.3"W x 19.6"D,, Seat height- 18"H

**DESCRIPTION:** Intellect Wave Cantilever chair easily stacks on desk, it's unique shell design has all the proper curves to support functionality and ergonomics in the classroom. Choose from an extensive selection of colors and finishes. Available as a poly shell, upholstered seat, or upholstered seat and back and book rack also available.

**KNEE CLEARANCE:** NA

**QUANTITY:**

Code	CH-004	Quantity
Room_Number		
A125		25
B118A		12
C108		35
C111		5
C112		11
A201		35
A202		35
A203		35
A204		35
A205		35
A206		35
A207		14
B214		4
SUB TOTAL		316

**IMAGE:**



**CODE** CH-005  
**ITEM:** Music Chair  
**MANUFACTURER:** Wenger Corp  
**MODEL:** Student Chair With Folding Tablet Arm  
**FINISHES:** Wedgewood color smooth plastic surface and black leg, glides for carpet use

**DIMENSIONS:** 16" Seat Height x 21- 1/2" Seat Depth x 19- 3/4" Seat Width x 31 -7/8" Chair Height

**DESCRIPTION:** Moveable, Stackable Chair, 16 gauge, square tube framing for increased durability. Polypropylene seat and back for even weight distribution & wear resistant. Chair design promotes easier breathing, generously sized seat and back for proper support, six different heights available to accommodate all musicians, chair glides provide increase durability and stability. Accepts folding tablet arm, storage rack, sousaphone and tuba rest, 5 yr Warranty.

**KNEE CLEARANCE:** NA

**QUANTITY:**

Code	CH-005	Quantity
Room_Number		
C112		23
SUB TOTAL		23

**IMAGE:**



**CODE** CH-006  
**ITEM:** Teacher Chair  
**MANUFACTURER:** Sit On It  
**MODEL:** Focus 5623 E A92  
**FINISHES:** Base Black Plastic , Seat Hype Sour- Momentum Fabric seat w/ Slate Mesh back, casters for carpet use  
**DIMENSIONS:** 27.5" X 26" X 41" X 17.5"-20.5" SH  
**DESCRIPTION:** High Back, Mesh back task chair with upholstered seat, knee tilt with Adjustable Arms

**KNEE CLEARANCE:** NA

**QUANTITY:**

Code	CH-006	Quantity
Room_Number		
A101		1
A106		1
A107		1
A112		1
A113		1
A118		1
A119		1
A122		1
A124		1
A124A		1
A125		1
A126		3
A130		1
B101		1
B107		1
B107A		1
B113		1
B118		1
B126		2
B132		1
B134		2
B138		1
B140		1
C104		1
C108		1
C111		1
C112		1
C118		1
C120		1
A201		1
A202		1
A203		1
A204		1
A205		1

A206	1
A207	1
A208	1
A214	1
A215	1
B201	1
B202	1
B204	1
B205	1
B214	1
<b>SUB TOTAL</b>	<b>48</b>

IMAGE:



**CODE:** CH-007  
**ITEM:** Teacher Reading Chair  
**MANUFACTURER:** Sit On It  
**MODEL:** Social- Armless  
**FINISHES:** Base Black Plastic , Seat Hype Tonic- Momentum Fabric seat w/ Slate Mesh back, glides for carpet use  
**DIMENSIONS:** 18" x 23" x 32"  
**DESCRIPTION:** Social meets and exceeds ANSI-BIFMA standards and features SitOnIt Seating's standard lifetime warranty. It is also GREENGUARD and GREENGUARD Children & Schools certified.

**KNEE CLEARANCE:** NA

**QUANTITY:**

Code	CH-007	Quantity
Room_Number		
A101		2
A106		2
A107		2
A113		2
A118		2
A119		2
A122		2
A123		5
A124		2
A124A		2
A130		2
B101		1
B106		1
B107		2
B123		6
B134		4
B138		2
B140		2
C108		2
C111		2
C112		2
A201		2
A202		2
A203		2
A204		2
A205		2
A206		2
A207		2
A208		2
A214		2
A215		2
B201		2
B202		2
B204		2

B205	2
B206	24
B214	2
A112	2
<b>SUB TOTAL</b>	<b>105</b>

**IMAGE:**

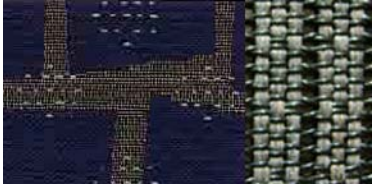



**CODE** CH-008  
**ITEM:** Waiting Chair  
**MANUFACTURER:** First Office  
**MODEL:** BALANCE Side Chair F37837  
**FINISHES:** Upholstered Seat and Back in Adler Illustrate- Maharam Fabric

**DIMENSIONS:** 22.75" x 22.625" x 32.25"

**DESCRIPTION:** With its sleek, modern lines Balance is intended for spaces desiring upgraded style with the necessity of comfort and value. Choose from three distinct back options to complete any office space: fully upholstered, open wood or open wood with décor rail. A solid hardwood frame ensures durability for long term wear.

**KNEE CLEARANCE:** NA

**QUANTITY:**

Code	CH-008	Quantity
Room_Number		
B126		10
B132		2
SUB TOTAL		12

**IMAGE:**



**CODE** CH-009  
**ITEM:** Stack Chair  
**MANUFACTURER:** KI  
**MODEL:** Matrix Stack Chair  
**FINISHES:** Splash-Seat and Back (fire retardant) Chrome FRAME  
  
**DIMENSIONS:** 19.5" X 16.25" X 32.25"  
**DESCRIPTION:** The Matrix chair with fixed seat and back cushions is designed to provide maximum support in a high density stack chair. Its curved fixed seat and backrest offer comfort at a complete price.

**KNEE CLEARANCE:** NA

**QUANTITY:**

Code	CH-009	Quantity
Room_Number		
C102		300
SUB TOTAL		300

**IMAGE:**



**CODE** CH-010  
**ITEM:** Conference Chairs  
**MANUFACTURER:** Focus Work  
**MODEL:** Mid-Back Upholstered w/ Fixed Arms Swivel Tilt, 5622t  
**FINISHES:** Black Frame with Juxtaposition Ultramarine- Designtex Fabric, casters for resilient flooring  
**DIMENSIONS:** 27.3" x 25" x 35"  
**DESCRIPTION:** Mid-Back Upholstered w/ Fixed Arms Swivel Tilt, 5622t

**KNEE CLEARANCE:** NA

**QUANTITY:**

Code	CH-010	Quantity
Room_Number		
B114		7
B139		8
SUB TOTAL		15

**IMAGE:**

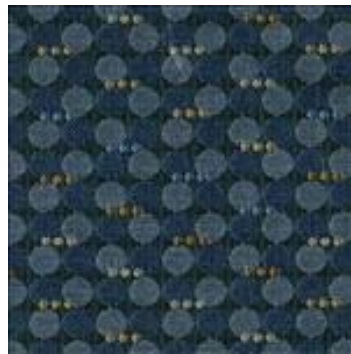

**CODE** CH-011  
**ITEM:** Couch  
**MANUFACTURER:** KI  
**MODEL:** Sela Sofa w/ Wood Arm Cap and Feet  
**FINISHES:** Grade I FABRIC WITH Contrast Seat Fabric and Cherry Storm Wood Arm Cap

**DIMENSIONS:** 78" x 33.5" x 28.25"

**DESCRIPTION:** The exceptional Sela lounge collection captures the less formal, casual lifestyle of today's students and workers while complementing a variety of interiors. Boasting a residential influence, the pieces reflect popular mid-century modern elements. Sela is well-built and smartly designed to meet uncompromising durability demands. Highly functional, the furnishings ensure both ease and comfort—precisely what a lounge space is intended to provide.

**KNEE CLEARANCE:** NA

**QUANTITY:**

Code	CH-011	Quantity
Room_Number		
B206		1
SUB TOTAL		1

**IMAGE:**



**CODE** CH-012  
**ITEM:** Arm Chairs  
**MANUFACTURER:** KI  
**MODEL:** SELA Lounge Chair with Tablet Arm  
**FINISHES:** Streetscape Blue on BlueFabric with Contrasting Seat Fabric and Cherry Storm Wood Arm Cap and Tablet Arm  
**DIMENSIONS:** 32" X 33.5" X 28.25"

**DESCRIPTION:** The exceptional Sela lounge collection captures the less formal, casual lifestyle of today's students and workers while complementing a variety of interiors. Boasting a residential influence, the pieces reflect popular mid-century modern elements. Sela is well-built and smartly designed to meet uncompromising durability demands. Highly functional, the furnishings ensure both ease and comfort—precisely what a lounge space is intended to provide

**KNEE CLEARANCE:** NA

**QUANTITY:**

Code	CH-012	Quantity
Room_Number		
B206		2
SUB TOTAL		2

**IMAGE:**



**CODE** CH-013  
**ITEM:** Task-Stool  
**MANUFACTURER:** Sit On it  
**MODEL:** Focus Stool Height 5622B1  
**FINISHES:** Base Black Plastic , Seat Hype Sour- Momentum Fabric seat w/ Slate Mesh back, casters for resilient flooring  
**DIMENSIONS:** 27.3" x 25" x 41.36"  
**DESCRIPTION:** Focus is GREENGUARD and GREENGUARD Children & Schools certified

**KNEE CLEARANCE:** NA

**QUANTITY:**

Code	CH-013	Quantity
Room_Number		
C122		1
SUB TOTAL		1

**IMAGE:**



**CODE** CH-014  
**ITEM:** Classroom Stools  
**MANUFACTURER:** KI  
**MODEL:** 618W-600 Series  
**FINISHES:** Steel, glides for resilient flooring  
  
**DIMENSIONS:** 18"H x 14" Seat Diameter, Cherry Storm seat, Warm Grey Frame  
**DESCRIPTION:** 600 Series Stool is constructed of steel with lacquered hardboard inset, comes with replaceable polyethylene feet.

**KNEE CLEARANCE:** NA

**QUANTITY:**

Code	CH-014	Quantity
Room_Number		
B118		30
C111		30
SUB TOTAL		60

**IMAGE:**



**CODE** CH-015  
**ITEM:** Recovery Couch  
**MANUFACTURER:** Clinton Industries  
**MODEL:** 3620-27  
**FINISHES:** Wedgewood 3WW Fabric with Dark Cherry 1DC Base laminate  
  
**DIMENSIONS:** 72" X 27" X 16"H  
**DESCRIPTION:** Hardwood Leg Couch with on adjustable wedge headrest

**KNEE CLEARANCE:** NA

**QUANTITY:**

Code	CH-015	Quantity
Room_Number		
B140		2
SUB TOTAL		2

**IMAGE:**





**CODE** CH-016  
**ITEM:** Exam Stool  
**MANUFACTURER:** Clinton Industries  
**MODEL:** 2175  
**FINISHES:** Wedgewood 3WW Fabric with Black Plastic 3BK Base, casters for resilient flooring  
**DIMENSIONS:** 16" DIA x 17.75"-23.25" H  
**DESCRIPTION:** 5-LEG Pneumatic Stool 23"; Powder Coated aluminum base on casters.

**KNEE CLEARANCE:** NA

**QUANTITY:**

Code	CH-016	Quantity
Room_Number		
B140		1
SUB TOTAL		1

**IMAGE:**



**CODE** CH-017  
**ITEM:** Immersive Theater Chairs  
**MANUFACTURER:** Avarte  
**MODEL:** Funktus 544 - Custom  
**FINISHES:** Vinyl Tubular Steel with Black frame, laminate arm rest and vinyl fabric  
  
**DIMENSIONS:** 24.6"L x 21.4" W x 38.5" H, seat height- 17.7" H  
**DESCRIPTION:** Custom, Stacking and linking chair. Low backrest, seat and backrest moulded birch veneer faced in black laminate or natural birch, other options available for projects.

**KNEE CLEARANCE:** NA

**QUANTITY:**

Code	CH-017	Quantity
Room_Number		
B122		110
SUB TOTAL		110

**IMAGE:**



**CODE** CH-018  
**ITEM:** Library Chairs  
**MANUFACTURER:** TMC Furniture  
**MODEL:** SFLC11315F- Fan  
**FINISHES:** Molded Plywood in Cherry finish, and black legs

**DIMENSIONS:** 16" x 18" x 28"

**DESCRIPTION:** The Flick Child chair is offered in three back shapes: square, arc or fan, and features the ease-of-use and stackability that comes with a 15" high metal wire sled base. The Flick Child chair stacks up to ten high

**KNEE CLEARANCE:** NA

**QUANTITY:**

Code	CH-018	Quantity
Room_Number		
B101		35
SUB TOTAL		35

**IMAGE:**



**CODE** CH-019  
**ITEM:** Library Soft Seating 1  
**MANUFACTURER:** Allermuir  
**MODEL:** Pebble-A620  
**FINISHES:** Designtex:Appleseed in Ocean Blue- 995

**DIMENSIONS:** 29" DIA X 17.5" H

**DESCRIPTION:** Pebble is a superb seating option for a multitude of informal meeting spaces or corporate breakout areas where people may come together for only a brief period to chat, to have a drink or just rest awhile.

**KNEE CLEARANCE:** NA

**QUANTITY:**

Code	CH-019	Quantity
Room_Number		
B101		8
SUB TOTAL		8

**IMAGE:**



**CODE** CH-020  
**ITEM:** Library Soft Seating 2  
**MANUFACTURER:** Allermuir  
**MODEL:** Pebble - A621 (scalloped)  
**FINISHES:** Designtex: Appleseed in Indigo 403

**DIMENSIONS:** 29" DIA X 17.5" H

**DESCRIPTION:** Pebble is a superb seating option for a multitude of informal meeting spaces or corporate breakout areas where people may come together for only a brief period to chat, to have a drink or just rest awhile.

**KNEE CLEARANCE:** NA

**QUANTITY:**

Code	CH-020	Quantity
Room_Number		
B101		8
SUB TOTAL		8

**IMAGE:**



**CODE** CH-021  
**ITEM:** Stool  
**MANUFACTURER:** Hertz Furniture- Troutman Chair  
**MODEL:** TRS-18N  
**FINISHES:** Lacquer solid wood

**DIMENSIONS:** 18.5"H x 13.5" Seat Diameter

**DESCRIPTION:** Natural wood finish. Superior Workmanship: These non-swivel stools are hand-crafted for premium quality. Extra Strong: Swelled-joint construction and interlocking joinery techniques mean that these stools can stand up to the rigors of everyday use. 100% Wood: Solid oak parts are extremely durable as well as attractive, 25 yr warranty.

**KNEE CLEARANCE:** NA

**QUANTITY:**

Code	CH-021	Quantity
Room_Number		
B118		30
SUB TOTAL		30

**IMAGE:**



**CODE:** D-001  
**ITEM:** Student Desk w/ Book Basket Box  
**MANUFACTURER:** KI  
**MODEL:** IWDCH/A: Intellect Adjustable Height Cantilever Desk  
**FINISHES:** Thermoset Plastic Top w/ book box  
**DIMENSIONS:** Top -19- 3/8" x 26 -3/4", 26"W x 19"D, Fixed top heights- 25", 27", 29", Adjustable top height  
**DESCRIPTION:** Intellect Wave Cantilever Desk hard plastic table top adjusts heights, &nbsp;all with extensive color and finish selections.

**KNEE CLEARANCE:** ADA Height Range 28" - 34".

**QUANTITY:**

Code	D-001	Quantity
Room_Number		
A122		2
C108		24
A201		23
A202		23
A203		23
A204		23
A205		23
A206		23
A214		23
A215		23
B201		23
B202		24
B204		23
B205		23
SUB TOTAL		303

**IMAGE:**



**CODE:** D-002  
**ITEM:** ADA Compliant Student Desk  
**MANUFACTURER:** KI  
**MODEL:** EDADA - Intellect ADA Desk  
**FINISHES:** Thermoset Plastic Top

**DIMENSIONS:** inside clear 30" / 28" x 34" Height Adjustable

**DESCRIPTION:** Get the right worksurface for any application in nearly indestructible hard plastic or high-pressure laminate. With glass-like smoothness, hard plastic tops provide the most desirable writing surfaces. Virtually scratchresistant, hard plastic tops are perfect for everyday use in demanding environments. Contemporary style provides open leg room for easier access and better comfort.

**KNEE CLEARANCE:** ADA Minimum clearance required: 30" w x 19" d x 27" h

**QUANTITY:**

Code	D-002	Quantity
Room_Number		
A122		1
C108		1
C112		1
A201		1
A202		1
A203		1
A204		1
A205		1
A206		1
A214		1
A215		1
B201		1
B202		1
B204		1
B205		1
<b>SUB TOTAL</b>		<b>15</b>

**IMAGE:**





**CODE:** D-003L  
**ITEM:** Teacher's Classroom Desk  
**MANUFACTURER:** Vanerum Stelter  
**MODEL:** Teacher's Desk w/ Freestanding Table  
**FINISHES:** Cherry Laminate

**DIMENSIONS:** 54" x 28" & 42" x 28"

**DESCRIPTION:** Teacher's Desk Bullet shape work surface with BBF Pedestal & tool shelf with dividers on 12" h supports & one grommet centered on work surface. Free standing Table: Curved on 2" h Tubular Legs with locking casters. Mobile Ped w/ 2" seat cushion BF.

**KNEE CLEARANCE:** ADA Minimum clearance required: 30" w x 19" d x 27" h

**QUANTITY:**

Code	D-003L	Quantity
Room_Number		
A101		1
A107		1
A113		1
A119		1
A122		1
B134		2
B138		1
C112		1
A201		1
A204		1
A205		1
A207		1
A214		1
B201		1
B204		1
<b>SUB TOTAL</b>		<b>16</b>

**IMAGE:**

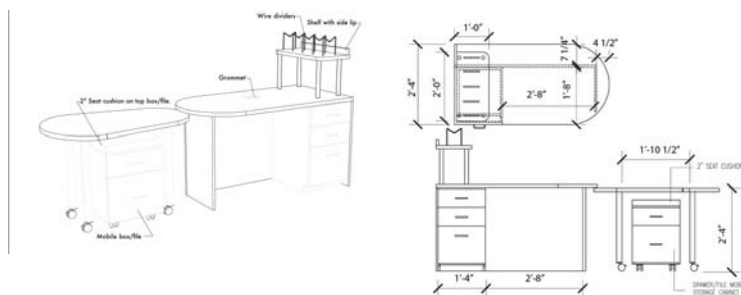

**CODE:** D-003R  
**ITEM:** Teacher's Classroom Desk  
**MANUFACTURER:** Vanerum Stelter  
**MODEL:** Teacher's Desk w/ Freestanding Table: SP.TB.18742-01 & SP.TD.18742-01  
**FINISHES:** Cherry Laminate

**DIMENSIONS:** 54" x 28" & 42" x 28"

**DESCRIPTION:** Teacher's Desk: Bullet shape work surface w/ BBF Pedestal & tool shelf with dividers on 12" h supports & one grommet centered on work surface. Free Standing Table: Curved on 2" Tubular Legs with locking casters. Mobile Ped w/ 2" seat cushion BF.

**KNEE CLEARANCE:** ADA Minimum clearance required: 30" w x 19" d x 27" h

**QUANTITY:**

Code	D-003R	Quantity
Room_Number		
A106		1
A112		1
A118		1
A125		1
A130		1
B118		1
C108		1
C111		1
A202		1
A203		1
A206		1
A208		1
A215		1
B202		1
B205		1
<b>SUB TOTAL</b>		<b>15</b>

**IMAGE:**

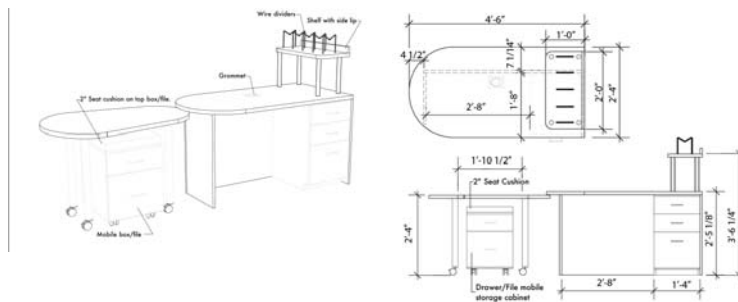

**CODE:** D-004  
**ITEM:** Small Private Office Desk  
**MANUFACTURER:** First Office  
**MODEL:** Vegas- Double Pedestal Desk  
**FINISHES:** Cherry Laminate with knife edge, straight grain, and grommet arc pull in vf satin nickel  
**DIMENSIONS:** 72" x 38" x 30"  
**DESCRIPTION:** Speed up the tempo and accelerate past the competition with the Vegas Collection. Cutting edge casegoods uniting wood, glass and metal for the ultimate in savvy design. Set the pace and customize a work space envied by all.

**KNEE CLEARANCE:** ADA Minimum clearance required: 30" w x 19" d x 27" h

**QUANTITY:**

Code	D-004	Quantity
Room_Number		
A124		1
A124A		1
A126		3
B107A		1
B113		1
C104		1
SUB TOTAL		8

**IMAGE:**



**CODE** D-005  
**ITEM:** Large Private Office Desk  
**MANUFACTURER:** First Office  
**MODEL:** Left U- Desk with Desk, Bridge, Cradenza & Acrylic Insert Highback Organizer  
**FINISHES:** Cherry Laminate with knife edge, straight grain, and grommet arc pull in vf satin nickel  
  
**DIMENSIONS:** 72" x 108" x 30"  
**DESCRIPTION:** 3-7238lpd2/ 3-2248br2 / 3-7222crr2

**KNEE CLEARANCE:** ADA Minimum clearance required: 30" w x 19" d x 27" h

**QUANTITY:**

Code	D-005	Quantity
Room_Number		
B107		1
B132		1
SUB TOTAL		2

**IMAGE:**

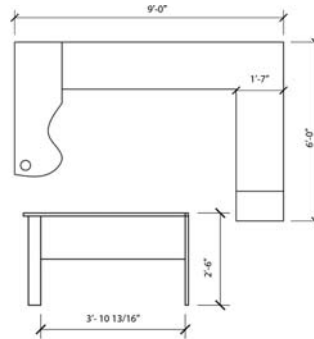

**CODE** D-006  
**ITEM:** Medium Private Office Desk  
**MANUFACTURER:** First Office  
**MODEL:** Vegas L-Shaped Desk  
**FINISHES:** Cherry Laminate with knife edge, straight grain, and grommet arc pull in vf satin nickel  
  
**DIMENSIONS:** 72" x 86" x 30"  
**DESCRIPTION:** 3-7238lpd2/ 3-224rpr2

**KNEE CLEARANCE:** ADA Minimum clearance required: 30" w x 19" d x 27" h

**QUANTITY:**

Code	D-006	Quantity
Room_Number		
B126		1
B140		1
SUB TOTAL		2

**IMAGE:**

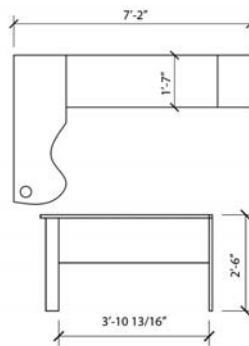

**CODE** D-007  
**ITEM:** Small Private Office Desk 2  
**MANUFACTURER:** Hon  
**MODEL:** 38180  
**FINISHES:** Metal

**DIMENSIONS:** 72" x 36" x 29.5"

**DESCRIPTION:** Built to last, Metro Classic's durable high-performance construction stands up to rigorous daily use. A complete office suite desking solution that includes desks, returns, credenzas and hutch storage cabinets. Practical and professional desk solution ideal for business and government offices.

**KNEE CLEARANCE:** ADA Minimum clearance required: 30"w x 19"d x 27"h

**QUANTITY:**

Code	D-007	Quantity
Room_Number		
C118		1
C120		1
SUB TOTAL		2

**IMAGE:**

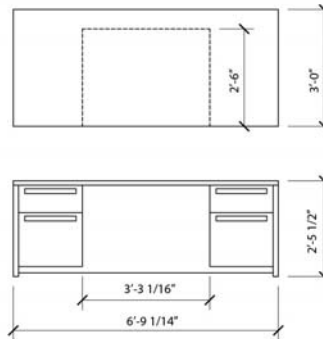

**CODE** D-008  
**ITEM:** Proof Mobile Desk  
**MANUFACTURER:** Vanerum Stelter  
**MODEL:** Proof Double Ped  
**FINISHES:** Cherry  
  
**DIMENSIONS:** 72" x 30" x 30"  
**DESCRIPTION:** Double pedestal on casters

**KNEE CLEARANCE:** ADA Minimum clearance required: 30"w x 19"d x 27"h

**QUANTITY:**

Code	D-008	Quantity
Room_Number		
B106		1
SUB TOTAL		1

**IMAGE:**



**CODE** E-001  
**ITEM:** Keyboards  
**MANUFACTURER:** Roland  
**MODEL:** Juno-Di  
**FINISHES:** NA

**DIMENSIONS:** 4 - 1/8" H x 39 - 11/16" W x 11 - 13/16" D

**DESCRIPTION:** 11lbs 8 oz light weight, can run on rechargeable batteries (supports Ni-MH AA-size rechargeable batteries), professional synthesizer with over 1,000 instruments onboard, easy user interface, &nbsp;MP3, WAV, AIFF, and SMF playback capability via optional USB memory, Microphone input with dedicated reverb and vocoder effects for sing-along, PC/Mac Editor software included, 1 yr Warranty.

**KNEE CLEARANCE:** NA

**QUANTITY:**

<b>Code</b>	<b>E-001</b>	
<b>Room_Number</b>		<b>Quantity</b>
C112		1
SUB TOTAL		1

**IMAGE:**





**CODE** E-002  
**ITEM:** RMP  
**MANUFACTURER:** Roland  
**MODEL:** BA-55  
**FINISHES:** Black

**DIMENSIONS:** 18 -15/16"H x 14"W x 10 -7/16"D

**DESCRIPTION:** 19lbs 14 oz. self-contained battery powered wireless PA system, designed for high quality sound for audiences up to 80 ppl. Sound Pressure Level rated 108 db, 2.4 Ghz wireless microphone included (DR-WM55). Operates on 8 AA batteries or AC power (AC adaptor included). Onboard accelerometer sensor switches operation to stereo mode when positioned horizontally, Two 6.5" high performance speakers, Three-channel built-in mixer with two-band EQ, Echo/Reverb effect, Built-in Anti-Feedback function, Line Output for recording or expanding the system, Integrated storage compartment, Auto Power Off function, Compatible with Roland ST-A95 speaker stand,

**KNEE CLEARANCE:** NA

**QUANTITY:**

Code	E-002	Quantity
Room_Number		
C112		1
SUB TOTAL		1

**IMAGE:**

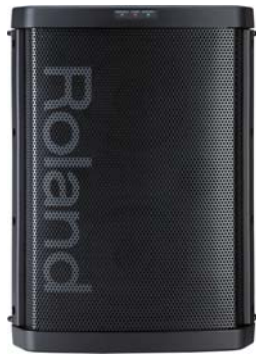

**CODE** E-003  
**ITEM:** Orff Instruments  
**MANUFACTURER:** West Music  
**MODEL:** 203815  
**FINISHES:** Rosewood

**DIMENSIONS:** NA

**DESCRIPTION:** The Studio 49 1600 Series West 52 Orff combination includes, 1 - BX 1600 - Rosewood Bass Xylophone (202165), 1 - AX 1600 - Rosewood Alto Xylophone (202164), 1 - SX 1600 - Rosewood Soprano Xylophone (202163), 1 - AM 1600- Alto Metallophone (202167), 1 - SM 1600 - Soprano Metallophone (202166), 1 - AGd - Alto Glockenspiel (200789), 1 - SGd - Soprano Glockenspiel (200791). Studio 49 instruments include F # and Bb bars along with appropriate mallets.

**KNEE CLEARANCE:** NA

**QUANTITY:**

Code	E-003	Quantity
Room_Number		
C112		1
SUB TOTAL		1

**IMAGE:**



**CODE** E-004  
**ITEM:** Music Mallets  
**MANUFACTURER:** West Music  
**MODEL:** 256121  
**FINISHES:** NA

**DIMENSIONS:** NA

**DESCRIPTION:** Set of West Music Mallets, perfect use as extra mallets for Sonor Orff Instruments and great to outfit your classroom. Includes 3 pair of soft yarn mallet for base xylophone or metallphone 255064, 6 pair medium yarn mallets for alto xylophone 255063, 2 pair hard yarn mallets for soprano xylophone 255062, 2 pair hard rubber glock mallets 255054, 2 pair very hard wood glock mallets &nbsp;255055, 3 each single soft yarn mallet for contra bass bars 255052.

**KNEE CLEARANCE:** NA

**QUANTITY:**

Code	E-004	Quantity
Room_Number		
C112		1
SUB TOTAL		1

**IMAGE:**



**CODE** E-005  
**ITEM:** Autoharp  
**MANUFACTURER:** West Music - Oscar Schmidt  
**MODEL:** 300002  
**FINISHES:** Maple body, gloss

**DIMENSIONS:** 11"H x 25"L x 14"W

**DESCRIPTION:** 13.8 lbs, Hand crafted, Maple Veneer Finish autoharp features 21 chords, hollow acoustic body, 8-ply rock maple pin block. The removable chord bar cover allows for the chords to be rearranged, designed to uphold against hard classroom use. 5yr Warranty, includes tuning wrench, flat pick, thumb pick, two-finger picks, and a padded gig bag. Chords included: majors (A, D, G, C, F, Bb, Eb, Ab), minors (E, A, D, G, C), and sevenths (F7, C7, G7, D7, A7, E7, B7, Bb7).

**KNEE CLEARANCE:** NA

**QUANTITY:**

Code	E-005	Quantity
Room_Number		
C112		1
SUB TOTAL		1

**IMAGE:**



**CODE** E-006  
**ITEM:** Block w/ Mallet  
**MANUFACTURER:** West Music  
**MODEL:** 201634  
**FINISHES:** NA

**DIMENSIONS:** 5 -7/8"L x 2"W x 1"D

**DESCRIPTION:** Basic Beat small rosewood, woodblock with &nbsp;wooden mallet. Includes a unique feature, with various depths of cut outs you get a choice of sounds.

**KNEE CLEARANCE:** NA

**QUANTITY:**

Code	E-006	Quantity
Room_Number		
C112		1
SUB TOTAL		1

**IMAGE:**



**CODE** E-007  
**ITEM:** Medium Wood Maracas  
**MANUFACTURER:** West Music  
**MODEL:** 201014  
**FINISHES:** Medium wood  
  
**DIMENSIONS:** 10" Long x 3" Diameter Oval Head (Per Pair)  
**DESCRIPTION:** Maracas with red & green stripes. Produces a delicate sound.

**KNEE CLEARANCE:** NA

**QUANTITY:**

Code	E-007	Quantity
Room_Number		
C112		1
SUB TOTAL		1

**IMAGE:**



**CODE** E-008  
**ITEM:** Hand Bells  
**MANUFACTURER:** West Music  
**MODEL:** 203763  
**FINISHES:** NA

**DIMENSIONS:** 0.2" x 5.5" x 4"

**DESCRIPTION:** The Basic beat sleigh bells include 5 bells mounted on leather attached to a wooden handle, 3.5 oz.

**KNEE CLEARANCE:** NA

**QUANTITY:**

Code	E-008	Quantity
Room_Number		
C112		1
SUB TOTAL		1

**IMAGE:**



**CODE** E-009  
**ITEM:** Triangles  
**MANUFACTURER:** West Music  
**MODEL:** 201548, 201549, 201550  
**FINISHES:** Chrome Steel  
  
**DIMENSIONS:** 4", 6", 7" Sizes  
**DESCRIPTION:** Includes striker and holder for each size.<br>
 <br>
 201548- 4" triangle is priced at \$ 22.00<br>
 201549- 6" triangle is priced at \$ 28.00<br>
 201550-7" triangle is priced at \$ 32.00

**KNEE CLEARANCE:** NA

**QUANTITY:**

Code	E-009	Quantity
Room_Number		
C112		1
SUB TOTAL		1

**IMAGE:**





**CODE** E-010  
**ITEM:** Tambourine  
**MANUFACTURER:** West Music  
**MODEL:** 201372  
**FINISHES:** Blue  
  
**DIMENSIONS:** 10" Diameter  
**DESCRIPTION:** Double Row, features a molded handle.

**KNEE CLEARANCE:** NA

**QUANTITY:**

<b>Code</b>	<b>E-010</b>	<b>Quantity</b>
Room_Number		
C112		1
SUB TOTAL		1

**IMAGE:**



**CODE** E-011  
**ITEM:** Tambourine  
**MANUFACTURER:** West Music-Remo  
**MODEL:** 201436  
**FINISHES:** Plastic shell, with synthetic head  
  
**DIMENSIONS:** 10" Diameter  
**DESCRIPTION:** Fixed, pre-tuned head, single row of jingles (8 pairs of jingles). Black Quadra finish rim, Fiberskyn 3 R head.

**KNEE CLEARANCE:** NA

**QUANTITY:**

Code	E-011	Quantity
Room_Number		
C112		1
SUB TOTAL		1

**IMAGE:**



**CODE** E-012  
**ITEM:** Finger Cymbals  
**MANUFACTURER:** West Music-Basic Beat  
**MODEL:** BB732  
**FINISHES:** Brass  
  
**DIMENSIONS:** 2- 1/4" Diameter  
**DESCRIPTION:** Cast Brass finger cymbals, set weights 0.7lbs, with black elastic straps securly sewn in place.

**KNEE CLEARANCE:** NA

**QUANTITY:**

Code	E-012	Quantity
Room_Number		
C112		1
SUB TOTAL		1

**IMAGE:**



**CODE** E-013  
**ITEM:** Wooden Guiro  
**MANUFACTURER:** West Music-Basic Beat  
**MODEL:** BB06  
**FINISHES:** Medium wood  
  
**DIMENSIONS:** 12" Long (sizes may vary, handmade)  
**DESCRIPTION:** Wood Fish Guiro includes scraper, handmade in Mexico.

**KNEE CLEARANCE:** NA

**QUANTITY:**

Code	E-013	Quantity
Room_Number		
C112		1
SUB TOTAL		1

**IMAGE:**



**CODE** E-014  
**ITEM:** Sound Shapes  
**MANUFACTURER:** West Music-Remo  
**MODEL:** SS-1000-06  
**FINISHES:** NA

**DIMENSIONS:** Set includes 6", 8", 10", 12", 14", 16" circles

**DESCRIPTION:** Includes 6 circular Sound Shapes a carrying bag with adjustable shoulder strap, padded carrying handle, and pocket for the mallets. Come in a variety of colors, may vary. Easily stored and stackable.

**KNEE CLEARANCE:** NA

**QUANTITY:**

Code	E-014	Quantity
Room_Number		
C112		1
SUB TOTAL		1

**IMAGE:**



**CODE** E-015  
**ITEM:** Kids Konga  
**MANUFACTURER:** West Music-Remo  
**MODEL:** 200590  
**FINISHES:** Rain forest Design Fabrifinish

**DIMENSIONS:** 6.5" Diameter x 15"High

**DESCRIPTION:** Pre-tuned kid's Percussion Konga, specifically designed for smaller hands. The Acousticon Shell is made of recycled hardwood fibers, unaffected by climate changes, Synthetic Fiberskyn 3 head gives the instrument it's authentic, ethnic drum sound. Drum can be played seated, or slung over the shoulder, includes shoulder strap.

**KNEE CLEARANCE:** NA

**QUANTITY:**

Code	E-015	Quantity
Room_Number		
C112		1
SUB TOTAL		1

**IMAGE:**



**CODE** E-016  
**ITEM:** Kids Tubano  
**MANUFACTURER:** West Music-Remo  
**MODEL:** 201578  
**FINISHES:** NA

**DIMENSIONS:** 22" x 10"

**DESCRIPTION:** Kids Percussion Tubano is designed for smaller hands, the Acousticon Shell is made of recycled hardwood fibers, unaffected by climate changes, Synthetic Fiberskyn 3 head gives the instrument it's authentic, ethnic drum sound. Includes shoulder strap.

**KNEE CLEARANCE:** NA

**QUANTITY:**

Code	E-016	Quantity
Room_Number		
C112		1
SUB TOTAL		1

**IMAGE:**



**CODE** E-017  
**ITEM:** Bean Bags  
**MANUFACTURER:** West Music  
**MODEL:** 200266  
**FINISHES:** NA

**DIMENSIONS:** 4" Square shape

**DESCRIPTION:** Set of 12, 4" square cloth bags filled with pellets. 2.5lbs each, machine washable/dryable. Easy to catch and throw, set includes 2 of each color; green, yellow, purple, navy, red, orange. Bean bag fabric is made of 100% polyester, and filling it 100% polypropylene plastic formed into uniform round pallets.

**KNEE CLEARANCE:** NA

**QUANTITY:**

<b>Code</b>	<b>E-017</b>	<b>Quantity</b>
Room_Number		
C112		1
SUB TOTAL		1

**IMAGE:**





**CODE** E-018  
**ITEM:** 5" Cymbals with Mallets  
**MANUFACTURER:** Music K-8 Marketpalce  
**MODEL:** MP-HP200  
**FINISHES:** Brass  
  
**DIMENSIONS:** 5" diameter  
**DESCRIPTION:** These dent-resistant brass cymbals come with attached handles so they can be used as crash cymbals, or to be suspended and hit with a mallet.

**KNEE CLEARANCE:** NA

**QUANTITY:**

Code	E-018	Quantity
Room_Number		
C112		1
SUB TOTAL		1

**IMAGE:**



**CODE** E-019  
**ITEM:** Rhythm Stick Kit  
**MANUFACTURER:** Music K-8 Marketplace  
**MODEL:** MP-FR100  
**FINISHES:** Natural wood in 6 colors (red, orange, yellow, green, blue, and purple)  
**DIMENSIONS:** 12" Long Sticks  
**DESCRIPTION:** Kit comes with &nbsp;24 wood sticks in 6 eyecatching colors. &nbsp;Kit also includes instructions, objectives, lessons and trick tips.

**KNEE CLEARANCE:** NA

**QUANTITY:**

Code	E-019	Quantity
Room_Number		
C112		1
SUB TOTAL		1

**IMAGE:**



**CODE** E-020  
**ITEM:** Eggz Shakers  
**MANUFACTURER:** Music K-8 Marketplace  
**MODEL:** MP-RT36 1  
**FINISHES:** ABS Plastic  
  
**DIMENSIONS:** NA ( 12 or more)  
**DESCRIPTION:** Eggz are tiny shakers, fun and easy to play. Come in assorted colors.

**KNEE CLEARANCE:** NA

**QUANTITY:**

Code	E-020	Quantity
Room_Number		
C112		1
SUB TOTAL		1

**IMAGE:**



**CODE** E-021  
**ITEM:** Upright Acoustic Piano with Bench  
**MANUFACTURER:** Yamaha  
**MODEL:** U3  
**FINISHES:** Polish Ebony

**DIMENSIONS:** 52"H x 60"W x 26"L

**DESCRIPTION:** Full length ribs into a notched liner ,Solid spruce soundboard and ribs ,Acoustibars ,Solid copper wound bass strings ,Hard maple bridges ,Aluminum alloy action rails ,Yamaha balanced action ,Spruce keys with hardwood buttons ,Grand piano key travel ,Cut thread tuning pins ,Mute pedal of the T121-U1-U3 ,Yamaha designed hammers with T-fasteners ,Polyester finish ,Resin sheet foundation ,Vacuum Shield Mold Process (V-Pro) plate, Seasoned for destination

**KNEE CLEARANCE:** NA

**QUANTITY:**

Code	E-021	Quantity
Room_Number		
C112		1
SUB TOTAL		1

**IMAGE:**



**CODE** E-022  
**ITEM:** Rice Cooker  
**MANUFACTURER:** Zojirushi  
**MODEL:** NP-HBC18  
**FINISHES:** Stainless Steel

**DIMENSIONS:** 9.31"H x 10.81"W x 15.63"D

**DESCRIPTION:** 10 Cup Rice Cooker, Multilevel Menu are for three levels (regular, softer, hard) with easy to read LCD control panel, Gaba Brown rice setting , interchangeable beeps and delays to keep food heated. Contains a thick spherical cooking pan and a detachable inner lid for easy clean up. 1 yr Warranty.

**KNEE CLEARANCE:** NA

**QUANTITY:**

Code	E-022	Quantity
Room_Number		
C108		2
SUB TOTAL		2

**IMAGE:**



**CODE** E-023  
**ITEM:** Water Heater  
**MANUFACTURER:** Zojirushi  
**MODEL:** CD-FAC22  
**FINISHES:** Silver

**DIMENSIONS:** 10"H x 8 -1/2"W x 11- 1/4"D

**DESCRIPTION:** Micom electric dispensing pot features a one touch dispensing system, easy to read LCD screen and dispense, computerized temperature control system, water level gauge, easy to clean non-stick interior, safety auto-shut off, easy to hear beep indicator to alert completion of boiling process or low water level, 3 keep warm temperature settings, holds 74 liters.

**KNEE CLEARANCE:** NA

**QUANTITY:**

<b>Code</b>	<b>E-023</b>	
<b>Room_Number</b>		<b>Quantity</b>
C108		2
<b>SUB TOTAL</b>		<b>2</b>

**IMAGE:**



**CODE** E-024  
**ITEM:** Junior Basketballs  
**MANUFACTURER:** US Games-Voit Enduro  
**MODEL:** 1335  
**FINISHES:** NA  
  
**DIMENSIONS:** 27.5"  
**DESCRIPTION:** Made of durable rubber, for recreational, indoor/outdoor use.

**KNEE CLEARANCE:** NA

**QUANTITY:**

Code	E-024	Quantity
Room_Number		
C101		25
SUB TOTAL		25

**IMAGE:**



**CODE** E-025  
**ITEM:** Playground Balls  
**MANUFACTURER:** US Games- Voit Balls  
**MODEL:** 1033472  
**FINISHES:** NA  
  
**DIMENSIONS:** 8 -1/2"  
**DESCRIPTION:** Set includes 1 ball of each color, blue, green, orange, purple, red and yellow. Top quality, widely used playground balls. Per Set

**KNEE CLEARANCE:** NA

**QUANTITY:**

Code	E-025	Quantity
Room_Number		
C101		4
SUB TOTAL		4

**IMAGE:**





**CODE** E-026  
**ITEM:** Softtouch Hockey Sticks  
**MANUFACTURER:** Sportime  
**MODEL:** 9007060112 & 9007058112  
**FINISHES:** NA  
  
**DIMENSIONS:** NA  
**DESCRIPTION:** Coated in foam, reshaped heads, includes a set of yellow sticks and a set of blue sticks, 7" ball and a 4" foam disc.  
 9007060112 is a double set that includes 20 sticks total, 10 of each color. \$229.99 for set  
 9007058112 is a regular set that includes 10 sticks total, 5 of each color. \$124.99 for set

**KNEE CLEARANCE:** NA

**QUANTITY:**

Code	E-026	Quantity
Room_Number		
C101		1
SUB TOTAL		1

**IMAGE:**



**CODE** E-027  
**ITEM:** Hockey Hotballs  
**MANUFACTURER:** Sportime- Shield  
**MODEL:** 91282655  
**FINISHES:** NA

**DIMENSIONS:** NA

**DESCRIPTION:** Comes in a set of 6 brightly colored balls, colors include red, yellow, blue, green, purple, orange. No bounce keeps balls in play. Work extremely well in any temperature and on any surface, soft feel is safer for kids.

**KNEE CLEARANCE:** NA

**QUANTITY:**

Code	E-027	Quantity
Room_Number		
C101		1
SUB TOTAL		1

**IMAGE:**



**CODE** E-028  
**ITEM:** Uncoated Foam Balls  
**MANUFACTURER:** US Games-Voit  
**MODEL:** 1181555  
**FINISHES:** Uncoated Foam Balls

**DIMENSIONS:** 5"

**DESCRIPTION:** Comes in a set of 6 balls in assorted colors, colors include blue, purple, red, yellow, orange and green. Balls are soft and low density, slower moving, restricted flight ball. Can be used indoors/outdoors, and is latex free. Per Set

**KNEE CLEARANCE:** NA

**QUANTITY:**

Code	E-028	Quantity
Room_Number		
C101		5
SUB TOTAL		5

**IMAGE:**



**CODE** E-029  
**ITEM:** Rainbow Plastic Cones  
**MANUFACTURER:** Gym Closet  
**MODEL:** 1887  
**FINISHES:** assorted plastic colors, blue, green, orange, purple, red, yellow.  
**DIMENSIONS:** 9"  
**DESCRIPTION:** Cones come in a set of 6 with 1 of each color. Can be used to color code activities, order of obstacles and &nbsp;team locations. Per Set

**KNEE CLEARANCE:** NA

**QUANTITY:**

Code	E-029	Quantity
Room_Number		
C101		8
SUB TOTAL		8

**IMAGE:**



**CODE** E-030  
**ITEM:** Half Cones  
**MANUFACTURER:** Sportime  
**MODEL:** 9006835  
**FINISHES:** Comes in assorted colors, Red, Yellow, Blue, Green, Orange and Violet.

**DIMENSIONS:** 9" H x 2"D

**DESCRIPTION:** Half cones comes in a set of 48 assorted colors, plus a handy storage/ carrying wire rack 8 each of 6 colors. &nbsp;Very light weight, virtually take up minimal space, can be used for many various activities and games. Per Set

**KNEE CLEARANCE:** NA

**QUANTITY:**

Code	E-030	Quantity
Room_Number		
C101		1
SUB TOTAL		1

**IMAGE:**



**CODE** E-031  
**ITEM:** Orange Cones  
**MANUFACTURER:** Sportime  
**MODEL:** 716170  
**FINISHES:** Orange polyethylene  
  
**DIMENSIONS:** 18"H  
**DESCRIPTION:** Highly flexible and visible for safety, heavy one piece keeps cones from falling over.

**KNEE CLEARANCE:** NA

**QUANTITY:**

Code	E-031	
Room_Number		Quantity
B126		12
C101		18
SUB TOTAL		30

**IMAGE:**



**CODE** E-032  
**ITEM:** Balance Board  
**MANUFACTURER:** US Games  
**MODEL:** 1008135  
**FINISHES:** NA

**DIMENSIONS:** NA

**DESCRIPTION:** 175lb weight limit, features an embedded z-shape track, extra tough molded construction with ribbed beams, includes 1 board, 2 fulcrums (3 height adjustments) and activity guide. Stay under control and the ball moves through the track.

**KNEE CLEARANCE:** NA

**QUANTITY:**

Code	E-032	Quantity
Room_Number		
C101		7
SUB TOTAL		7

**IMAGE:**



**CODE** E-033  
**ITEM:** Scrimmage Vests  
**MANUFACTURER:** US Games  
**MODEL:** C46Y  
**FINISHES:** NA

**DIMENSIONS:** One Size Fits all-Youth

**DESCRIPTION:** Latex Free, Polyester Mesh &nbsp;intramural vest. Reinforced neck and arm holes with elastic waistband. Comes in assorted colors, colors include gold, kelly, orange, purple, royal, scarlet, black.

**KNEE CLEARANCE:** NA

**QUANTITY:**

<b>Code</b>	<b>E-033</b>	
<b>Room_Number</b>		<b>Quantity</b>
C101		14
SUB TOTAL		14

**IMAGE:**





**CODE** E-034  
**ITEM:** Volleyball Net  
**MANUFACTURER:** Volleyball USA  
**MODEL:** VB1350K  
**FINISHES:** White Vinyl

**DIMENSIONS:** 34"W x 39"H

**DESCRIPTION:** 3mm hollow braid treated black netting, white 2" 18oz vinyl wrapped around net enclosing wooden dowels (7/8"), ultra strong kevlar cord top. #6 white MFP rope bottom, rope racheting tool kit and carrying bag included.

**KNEE CLEARANCE:** NA

**QUANTITY:**

Code	E-034	Quantity
Room_Number		
C101		1
SUB TOTAL		1

**IMAGE:**



**CODE** E-035  
**ITEM:** Ball Inflator  
**MANUFACTURER:** School Specialty  
**MODEL:** 087966  
**FINISHES:** NA

**DIMENSIONS:** 5 -1/2" x 7 -1/2"

**DESCRIPTION:** Vibration free operation, built in on/off switch, 8' (3-prong), 120V electric cord, extra long, flexible hose, 40 psi air gauge and control valve, includes needle, tapered adapter.

**KNEE CLEARANCE:** NA

**QUANTITY:**

Code	E-035	Quantity
Room_Number		
C101		1
SUB TOTAL		1

**IMAGE:**



**CODE** E-036  
**ITEM:** Poly Spot Markers  
**MANUFACTURER:** US Games  
**MODEL:** 6059  
**FINISHES:** NA

**DIMENSIONS:** 9" Diameter

**DESCRIPTION:** These orange markers come in a set of 24, flat markers, soft and flexible plastic. Sticks to Gym floors without shifting, latex free.

**KNEE CLEARANCE:** NA

**QUANTITY:**

<b>Code</b>	<b>E-036</b>	<b>Quantity</b>
Room_Number		
C101		1
SUB TOTAL		1

**IMAGE:**



**CODE** E-037  
**ITEM:** Poly Spot Markers 9"  
**MANUFACTURER:** US Games  
**MODEL:** 6058  
**FINISHES:** NA

**DIMENSIONS:** 9" Diameter

**DESCRIPTION:** These lortex free, flat floor markers come in assorted colors that include, blue, green, orange, purple, red, yellow. Markers are flexible, plastic, soft and stick to Gym floors without shifting. Per set

**KNEE CLEARANCE:** NA

**QUANTITY:**

<b>Code</b>	<b>E-037</b>	<b>Quantity</b>
<b>Room_Number</b>		
C101		2
<b>SUB TOTAL</b>		2

**IMAGE:**



**CODE** E-038  
**ITEM:** Jump Rope x2 Dutch  
**MANUFACTURER:** US Games  
**MODEL:** 17314  
**FINISHES:** NA  
  
**DIMENSIONS:** 14' Rope  
**DESCRIPTION:** Includes a pair of durable plastic ropes with loops handles, colors may vary.

**KNEE CLEARANCE:** NA

**QUANTITY:**

Code	E-038	Quantity
Room_Number		
C101		8
SUB TOTAL		8

**IMAGE:**



**CODE** E-039  
**ITEM:** Jump ropes  
**MANUFACTURER:** US Games  
**MODEL:** 17207  
**FINISHES:** NA  
  
**DIMENSIONS:** 7' Rope  
**DESCRIPTION:** Great for speed jumping, injection, molded handles for comfort and free spin. Plastic rope and durable

**KNEE CLEARANCE:** NA

**QUANTITY:**

Code	E-039	Quantity
Room_Number		
C101		30
SUB TOTAL		30

**IMAGE:**



**CODE** E-040  
**ITEM:** Chinese Jump Ropes  
**MANUFACTURER:** Sportime  
**MODEL:** 029850112  
**FINISHES:** NA

**DIMENSIONS:** 8' Rope

**DESCRIPTION:** Ropes come in a set of 6 in purple, they are safe and can be used in a variety of games and activities . The rugged construction holds up to school use.

**KNEE CLEARANCE:** NA

**QUANTITY:**

<b>Code</b>	<b>E-040</b>		<b>Quantity</b>
	<b>Room_Number</b>		
	C101		2
	<b>SUB TOTAL</b>		2

**IMAGE:**



**CODE** E-041  
**ITEM:** Pulse Monitors  
**MANUFACTURER:** Gym Closet- Sportline Solo  
**MODEL:** 6904  
**FINISHES:** Silver

**DIMENSIONS:** NA

**DESCRIPTION:** The Solo 910 has One touch technology, a single touch delivers ECG heart rate measurements within seconds and measures calories burned. Features 12/24 time setting, chronograph, large digital display, back light, alarm, countdown timer, water resistant up to 30 meters and has an hourly chime.

**KNEE CLEARANCE:** NA

**QUANTITY:**

Code	E-041	Quantity
Room_Number		
C101		24
SUB TOTAL		24

**IMAGE:**





**CODE** E-042  
**ITEM:** Pulse Monitors  
**MANUFACTURER:** Gym Closet-Biosig  
**MODEL:** 1143  
**FINISHES:** NA  
  
**DIMENSIONS:** 11" Long  
**DESCRIPTION:** Pulse is quickly calculated and displayed by grasping the metal contact rings on tool. Available with optional wall mount, or floor stand, uses a 9volt battery (included).

**KNEE CLEARANCE:** NA

**QUANTITY:**

Code	E-042	Quantity
Room_Number		
C101		4
SUB TOTAL		4

**IMAGE:**



**CODE** E-043  
**ITEM:** CD /Tape Player  
**MANUFACTURER:** Sportime - Califone  
**MODEL:** 1320547  
**FINISHES:** Beige

**DIMENSIONS:** 18-1/4"L x 6-1/2"W x 8-1/2"H

**DESCRIPTION:** multifunctional ac/dc, 12 dual tape/ cd player, plays fm-am radio, digital controls, built in electret microphone, 6 watt RMS amplifier, headphones jack, external speaker jack, remote control, 20 track programmable top loading cd player, cd memory, cd-r/rw compatibility, high impact abs housing, 12lbs, operates on 8-D batteries or 120VAC.

**KNEE CLEARANCE:** NA

**QUANTITY:**

Code	E-043	Quantity
Room_Number		
C101		1
SUB TOTAL		1

**IMAGE:**



**CODE** E-044  
**ITEM:** Voice Blaster  
**MANUFACTURER:** US Games  
**MODEL:** 1162769  
**FINISHES:** NA

**DIMENSIONS:** Speaker measure 2.5" with adjustable belt that meausre up to 50"

**DESCRIPTION:** Made from Heavy duty plastic, operates on 6 AA batteries (not included) lasts up to 8 hrs, includes a re-chargable battery adapter. 5 Watts

**KNEE CLEARANCE:** NA

**QUANTITY:**

Code	E-044	Quantity
Room_Number		
C101		1
SUB TOTAL		1

**IMAGE:**



**CODE** E-045  
**ITEM:** Mats-1  
**MANUFACTURER:** Sportime  
**MODEL:** 1306559  
**FINISHES:** NA

**DIMENSIONS:** 4' x 8'

**DESCRIPTION:** Crunchmats feature Sportime 2' panels on 2' folding Expand-O-Mats, when turned over turn into abdominal-crunch platforms. Crunchlines are 8' L x 3" W and 4 1/2" W (measurements are national standards for abdominal crunch distances for k-4, 5+). Each Crunchline has raised edges and lightly textured surfaces so that students can demonstrate correct crunch movements without looking down. The Crunch platform technique maximizes the # of students per 8' area and permanently prevents curling or movement of the line.

**KNEE CLEARANCE:** NA

**QUANTITY:**

Code	E-045	Quantity
Room_Number		
C101		2
SUB TOTAL		2

**IMAGE:**



**CODE** E-046  
**ITEM:** Mats-2  
**MANUFACTURER:** US Games-GSC  
**MODEL:** 1041569  
**FINISHES:** NA

**DIMENSIONS:** 5' x 10'

**DESCRIPTION:** Ultimat mats are the firmest and lightest mats. Available in 1' or 2' panels that folds into 2' panels for easier handling and storage. Ultimat mats provide high shock absorbency and no bottoming out for high impact activities. Includes 2 fasteners on both ends, are available for 4 on all sides for extra flexibility. Ultimat mats are upholstered with 18 oz. vinyl, knife coated on both sides, fabric provides great strength to resist tears and punctures. Mats resist fungus, bacteria and mildew. Available in Royal Blue.

**KNEE CLEARANCE:** NA

**QUANTITY:**

Code	E-046	Quantity
Room_Number		
C101		14
SUB TOTAL		14

**IMAGE:**



**CODE** E-047  
**ITEM:** Mats-3  
**MANUFACTURER:** US Games-GSC  
**MODEL:** 1041712  
**FINISHES:** NA

**DIMENSIONS:** 6'L x 4'W x 16"H

**DESCRIPTION:** Folding down hill mats are great for teaching beginner gymnasts basic rolls and walkovers. Mats are filled with polyurethane foam and covered in 18 oz reinforced, coated vinyl. Available in multicolors only.

**KNEE CLEARANCE:** NA

**QUANTITY:**

Code	E-047	Quantity
Room_Number		
C101		1
SUB TOTAL		1

**IMAGE:**



**CODE** E-048  
**ITEM:** Mat Cart  
**MANUFACTURER:** US Games  
**MODEL:** 20023582  
**FINISHES:** Galvanized Steel tubing  
  
**DIMENSIONS:** 8' -8"L x 4'W, 2" tube framing  
**DESCRIPTION:** Flat mat truck, rugged, heavy duty and built to last with non-marring wheels.

**KNEE CLEARANCE:** NA

**QUANTITY:**

Code	E-048	Quantity
Room_Number		
C101		1
SUB TOTAL		1

**IMAGE:**



**CODE** E-049  
**ITEM:** Pull Up Bars  
**MANUFACTURER:** Sportime  
**MODEL:** 013117  
**FINISHES:** Steel

**DIMENSIONS:** Adjustable height from 5'-7", 80" base, 1- 3/4" steel uprights, 1 -1/4" base bar

**DESCRIPTION:** Portable Chin up Bar accomodates 2 students at one time up to 350lbs, no marring pads on all 4 feet.

**KNEE CLEARANCE:** NA

**QUANTITY:**

Code	E-049	Quantity
Room_Number		
C101		2
SUB TOTAL		2

**IMAGE:**





**CODE** E-050  
**ITEM:** Power Climbers  
**MANUFACTURER:** Sportime  
**MODEL:** 7008729  
**FINISHES:** NA

**DIMENSIONS:** 41 -1/2"H x 12"W

**DESCRIPTION:** Power Climbers can handle up to 200lbs till recommended grade 8. It has 7 rungs per side, angles away from wall so climbers don't slide over lower rungs as they climb higher. Constructed from hardwood, includes mounting hardware. PROVIDE & INSTALL

**KNEE CLEARANCE:** NA

**QUANTITY:**

Code	E-050	Quantity
Room_Number		
C101		1
SUB TOTAL		1

**IMAGE:**



**CODE** E-051  
**ITEM:** Fish Tank Set Up 1  
**MANUFACTURER:** Exotic Fish and Corals  
**MODEL:** Various  
**FINISHES:** NA

**DIMENSIONS:** 72" X 24" X 30"

**DESCRIPTION:** 218 Gallon regular tank- clear silicon / 3 glass tops/ 2 heaters-visitherm / 2 canister filters - Eheim / 6 bags of fresh water gravel / 1 PH 7.0 neutral conditioner / 6 misc deco for tank / 2 boxes of South African lace rock / 1 micron powerhead / 1 double 6 foot flourescent light with bulbs. &nbsp;ITEM MUST BE INSTALLED & TRAINING NEEDS TO BE INCOORPORATED IN PRICING.

**KNEE CLEARANCE:** NA

**QUANTITY:**

Code	E-051	Quantity
Room_Number		
B118A		1
SUB TOTAL		1

**IMAGE:**

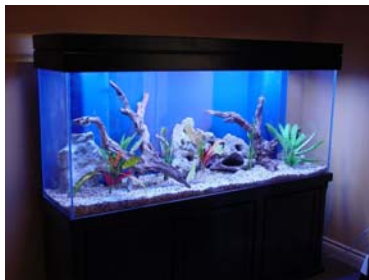

**CODE** E-052  
**ITEM:** Playground Balls  
**MANUFACTURER:** US Games  
**MODEL:** 1233179  
**FINISHES:** NA

**DIMENSIONS:** 8.5"

**DESCRIPTION:** Rainbow balls come in a set of 48 balls in 6 different colors with 8 balls of each. Colors include blue, green, orange, red, purple, and yellow.

**KNEE CLEARANCE:** NA

**QUANTITY:**

<b>Code</b>	<b>E-052</b>	<b>Quantity</b>
Room_Number		
C101		2
SUB TOTAL		2

**IMAGE:**



**CODE** E-053  
**ITEM:** Basketballs  
**MANUFACTURER:** US Games-MacGregor  
**MODEL:** 934021  
**FINISHES:** Purple  
  
**DIMENSIONS:** Junior Size  
**DESCRIPTION:** Durable rubber construction, for indoor/outdoor and recreational use.

**KNEE CLEARANCE:** NA

**QUANTITY:**

Code	E-053	Quantity
Room_Number		
C101		9
SUB TOTAL		9

**IMAGE:**



**CODE** E-054  
**ITEM:** Basketballs  
**MANUFACTURER:** US Games-MacGregor  
**MODEL:** 934021  
**FINISHES:** Blue  
  
**DIMENSIONS:** Junior Size  
**DESCRIPTION:** Durable rubber construction, for indoor/outdoor and recreational use.

**KNEE CLEARANCE:** NA

**QUANTITY:**

Code	E-054	Quantity
Room_Number		
C101		9
SUB TOTAL		9

**IMAGE:**



**CODE:** E-055  
**ITEM:** Basketballs  
**MANUFACTURER:** US Games-MacGregor  
**MODEL:** 934021  
**FINISHES:** Green  
  
**DIMENSIONS:** Junior Size  
**DESCRIPTION:** Durable rubber construction, for indoor/outdoor and recreational use.

**KNEE CLEARANCE:** NA

**QUANTITY:**

Code	E-055	Quantity
Room_Number		
C101		9
SUB TOTAL		9

**IMAGE:**



**CODE** E-056  
**ITEM:** Hula Hoops  
**MANUFACTURER:** US Games  
**MODEL:** 02170- 36" & 02160- 30"  
**FINISHES:** Come in a variety of colors 2 of each , blue, green, orange, purple, red, and yellow.  
  
**DIMENSIONS:** 36" Diameter and 30" Diameter  
**DESCRIPTION:** Premium no kink hoops have thick walls to prevent kinking.<br>
 <br>
 02170- 36" hoops are priced at \$68.99<br>
 02160 - 30" hoops are priced at \$64.99

**KNEE CLEARANCE:** NA

**QUANTITY:**

Code	E-056	Quantity
Room_Number		
C101		10
SUB TOTAL		10



**CODE** E-057  
**ITEM:** Mesh Bags for Vests  
**MANUFACTURER:** Sportime  
**MODEL:** 018556  
**FINISHES:** Black and White Industrial Grade Mesh  
  
**DIMENSIONS:** 18 -1/2" x 36"  
**DESCRIPTION:** Better and stronger than any mesh bag, perfect for it's intended use. Includes drawstring (3/8" & quot;)

**KNEE CLEARANCE:** NA

**QUANTITY:**

Code	E-057	Quantity
Room_Number		
C101		1
SUB TOTAL		1

**IMAGE:**





**CODE** E-058  
**ITEM:** Fish Tank Set Up 2  
**MANUFACTURER:** Exotic Fish and Corals  
**MODEL:** Varies  
**FINISHES:** NA

**DIMENSIONS:** 72" X 24" X 30"

**DESCRIPTION:** 218 Gallon delux tank - reef ready / 1 reef buffer / 2 reef ready plumbing kits/ 1 complete wet / dry filter systems / 1 salt Bearing Pump / 1 protein skimmer with pump / 1 57 watt with system pump / 1 micron filter up to 5 micron/ 10 bags of fresh imported live sand / 125 lbs of reef live rock / 1 refractometer / 1 set of test kits: PH /Nitrate / Nitriten / 1 full controlled heating system - in line / 1 magnet scrapper/ 1 vortex wave maker / 2 buckets of Brightwell salt mix / plumbing as needed / &nbsp;3 LED Lights Fully Controlled power & Timers. TANK NEEDS TO BE FULLY ASSEMBLED & PRICING NEEDS TO INCLUDE TRAINING.

**KNEE CLEARANCE:** NA

**QUANTITY:**

Code	E-058	Quantity
Room_Number		
B118A		1
SUB TOTAL		1

**IMAGE:**



**CODE** E-059  
**ITEM:** Nerf Footballs  
**MANUFACTURER:** US Games  
**MODEL:** 44095  
**FINISHES:** Tuff Coated Foam comes in a variety of colors, red, orange, yellow, green, blue, and purple.  
**DIMENSIONS:** 9- 3/4"  
**DESCRIPTION:** Lightweight and heavy enough for quality football action.

**KNEE CLEARANCE:** NA

**QUANTITY:**

Code	E-059	Quantity
Room_Number		
C101		9
SUB TOTAL		9

**IMAGE:**



**CODE** E-060  
**ITEM:** Outdoor Basketball Hoop Nets  
**MANUFACTURER:** Hoops Direct-Goal Sporting Goods  
**MODEL:** 20731  
**FINISHES:** White- Off white  
  
**DIMENSIONS:** 21'L- 12 Loop  
**DESCRIPTION:** Extra Heavy duty net provides long lasting play, no assembly,anti-whip net.

**KNEE CLEARANCE:** NA

**QUANTITY:**

Code	E-060	Quantity
Room_Number		
C101		2
SUB TOTAL		2

**IMAGE:**



**CODE** E-061  
**ITEM:** Vacuum Backpack  
**MANUFACTURER:** ProTeam  
**MODEL:** Super CoachVac  
**FINISHES:** White

**DIMENSIONS:** 47" x 27" x 26"

**DESCRIPTION:** Proteam Supercoach backpack vacuum cleaner weighs 11 lbs, 66 dB, 150 cfm, 1 - 1/2" hose for 100' of static lift, 1188 watts, 9.9 amps, 50' extension cord, 10 qt vacuum with tool kit, 1136 sq ft of 4 level filtration.

**KNEE CLEARANCE:** NA

**QUANTITY:**

Code	E-061	Quantity
Room_Number		
B215		4
SUB TOTAL		4

**IMAGE:**



**CODE** E-062  
**ITEM:** Carpet Cleaner  
**MANUFACTURER:** Tenant  
**MODEL:** R-3 Compact, Rapid-drying Carpet Cleaner  
**FINISHES:** polythylene  
  
**DIMENSIONS:** 28"H x 30"L x 19"W  
**DESCRIPTION:** 1.2 hp motor power, 5 gallon tank capacity, roller rpm 450rpm, motor rpm 1600 rpm. 65 PSI water pressure, 69 dBA, 15" cleaning path, 3 yr warranty.

**KNEE CLEARANCE:** NA

**QUANTITY:**

Code	E-062	Quantity
Room_Number		
B215		1
SUB TOTAL		1

**IMAGE:**



**CODE** E-063  
**ITEM:** Boom Lift- Electric  
**MANUFACTURER:** JLG  
**MODEL:** E300AJD  
**FINISHES:** NA  
  
**DIMENSIONS:** 30FT PLATFORM / 4FT WIDE/ 500LB CAPACITY  
**DESCRIPTION:** Off road boom lift to be able to reach top of planetarium roof for service.

**KNEE CLEARANCE:** NA

**QUANTITY:**

Code	E-063	Quantity
Room_Number		
B215		1
SUB TOTAL		1

**IMAGE:**



**CODE** E-064  
**ITEM:** Wet/Dry Vacuum  
**MANUFACTURER:** Tennant  
**MODEL:** 3500/607673  
**FINISHES:** Rugged Polyethylene  
  
**DIMENSIONS:** 37.5"H x 29"L x 15.5"W

**DESCRIPTION:** Tennant wet/dry vacuum on wheels, 15 gallon capacity with optional front mount squeegee and wand fit. 10/3/3 Warranty, 120V motor operates in 2 stages 1.3hp or 1.6 hp, built in handle for easy transport, includes 50' power cord.

**KNEE CLEARANCE:** NA

**QUANTITY:**

Code	E-064	Quantity
Room_Number		
B215		1
SUB TOTAL		1

**IMAGE:**



**CODE** E-065  
**ITEM:** Floor Scrubber  
**MANUFACTURER:** Tenant  
**MODEL:** T-7 Micro-rider Floor Scrubber  
**FINISHES:** N/A  
  
**DIMENSIONS:** 50"H x 60"L x 33.25"W with 2-16" pads  
**DESCRIPTION:** Cleaning width, Micro rider scrubber battery run time up to 3 hrs at 225 rpm, 29 gallon tank capacity. Vacuum power 0.6 hp, minimum aisle turn- 72.5", cleans 39,600 sq.ft/hr.

**KNEE CLEARANCE:** NA

**QUANTITY:**

Code	E-065	Quantity
Room_Number		
B215		1
SUB TOTAL		1

**IMAGE:**





**CODE** E-066  
**ITEM:** Floor Machine  
**MANUFACTURER:** Milestone Equipment- General Floorcraft Floor Maintenance  
**MODEL:** KC-20 Series  
**FINISHES:** Chrome

**DIMENSIONS:** Brush Diameter- 21" x 13 -1/4"H.

**DESCRIPTION:** General heavy duty floor machine, 1hp 20" pad, 175 rpm's, services all types of floor maintenance, heavy-duty all steel gear transmission. Non-marking bumper, semi-pneumatic tires, safety switch levers, fully adjustable handle, ultra quiet motor.

**KNEE CLEARANCE:** NA

**QUANTITY:**

Code	E-066	Quantity
Room_Number		
B215		1
SUB TOTAL		1

**IMAGE:**



**CODE** E-067  
**ITEM:** Floor Burnisher  
**MANUFACTURER:** Grainger-Nobles  
**MODEL:** 4VDX2  
**FINISHES:** NA

**DIMENSIONS:** 52"L x 24"W x 40"H

**DESCRIPTION:** High Speed battery powered floor burnisher, 20" pad- dust control cloth fiber to .3 microns &nbsp;at 99% ,2500 RPM, motor HP3, includes 2 15 AH batteries, flexible pad driver and variable pad pressure and rotationally molded. Low profile design for cleaning under shelves and fixtures, Covers up 21,00 sq. ft/ hr and runs on 2.5 hrs from a single charge. Provides 15-40lbs of pad pressure. 3 yr Warranty.

**KNEE CLEARANCE:** NA

**QUANTITY:**

Code	E-067	Quantity
Room_Number		
B215		1
SUB TOTAL		1

**IMAGE:**



**CODE** E-068  
**ITEM:** Snow Blower  
**MANUFACTURER:** Honda  
**MODEL:** HS928WAS  
**FINISHES:** NA

**DIMENSIONS:** 57.7"L x 28.5"W x 43.9"H

**DESCRIPTION:** 2 Stage wheel drive snow blower, 10hp, electric start, self propelled, 28" clearing width and 20" clearing height, reversible 2 position skid shoes, automatic decompression. Adjustable snow deflection, ice breaking serrated auger, 2 ply tires, convenient control levers. Built in icing guard, work light, taller fuel cap, and 3 yr. residential/commerical Warranty.

**KNEE CLEARANCE:** NA

**QUANTITY:**

Code	E-068	Quantity
Room_Number		
B215		1
SUB TOTAL		1

**IMAGE:**



**CODE** E-069  
**ITEM:** Cleaning System  
**MANUFACTURER:** KaiVac  
**MODEL:** 1250  
**FINISHES:** NA

**DIMENSIONS:** 38"H x 22"L x 20"W

**DESCRIPTION:** 110V Kaivac no-touch cleaning system is compact, lightweight and easy to maneuver. High powered indoor pressure water, wet vacuum motor, dumping and filling, chemical metering, removable engine compartment, quiet operation, HEPA filtration exhaust and blow. Hold up to 12 gallons of water, sprays for 16 mins/ up to 32', pressure 500psi, vacuum tank holds 8 gallons. Rubber tires, molded in handle, parking break. Includes additional tools; 2 piece vac wand, 14" squeegee hand, blow nozzle, kaibrush, window squeegee, metering tip kit, kai drain, 15 gal tote bag. 93.5lbs. 10 yr body warranty, 3 yr parts warranty, 1 yr labor warranty.

**KNEE CLEARANCE:** NA

**QUANTITY:**

Code	E-069	Quantity
Room_Number		
B215		1
SUB TOTAL		1

**IMAGE:**



**CODE** E-070  
**ITEM:** Electric Pressure Washer  
**MANUFACTURER:** Grainger  
**MODEL:** 3WB88  
**FINISHES:** NA

**DIMENSIONS:** 42"L x 26"W x 28"H

**DESCRIPTION:** Electric cold water pressure washer, 230v, 6.0 HP, 2500psi &nbsp;operating pressure,20+ usable hours/per week. Single phase, Crankshaft pump, solid steel axles and pneumatic tires, 25' hose x 3/8" diameter,225lbs.

**KNEE CLEARANCE:** NA

**QUANTITY:**

Code	E-070	Quantity
Room_Number		
B215		1
SUB TOTAL		1

**IMAGE:**



**CODE** E-071  
**ITEM:** Heat Buster Fan  
**MANUFACTURER:** Industrial Fans Direct  
**MODEL:** TPC4213  
**FINISHES:** Bronze powder coat  
  
**DIMENSIONS:** 45"H x 44"W x 27"D  
**DESCRIPTION:** Fan has full width easy grip handle, 4 deep pitch blades, automatic drive belt tension, heavy gauge cold rolled steel barrels, rubber tread wheels. Spiral wound wire guard meets OSHA, 3 yr Warranty, 1 speed fan, 115 or 460V, 153lbs.

**KNEE CLEARANCE:** NA

**QUANTITY:**

Code	E-071	Quantity
Room_Number		
B215		1
SUB TOTAL		1

**IMAGE:**



**CODE** E-072  
**ITEM:** Carpet Dryer  
**MANUFACTURER:** Minuteman  
**MODEL:** C42000-01  
**FINISHES:** Polythylene  
  
**DIMENSIONS:** 20"H x 15"L x 17"W  
**DESCRIPTION:** Carpet blower, 1hp, 115v, 3 speed, 25' power cord and conviential onboard storage, 11" propeller diameter, 37lbs.

**KNEE CLEARANCE:** NA

**QUANTITY:**

Code	E-072	Quantity
Room_Number		
B215		1
SUB TOTAL		1

**IMAGE:**







**CODE:** E-074  
**ITEM:** Eight Foot Fiber Glass Step Ladder  
**MANUFACTURER:** American Ladder  
**MODEL:** 7408  
**FINISHES:** Fiberglass

**DIMENSIONS:** 28- 1/2"W x 55- 1/4" Spread, Top- 7- 1/4" x 14 -7/8", Steps- 3" Wide

**DESCRIPTION:** Eight foot fiberglass step ladder, rated for 350lbs, &nbsp;extra heavy aluminum top, slip resistant taction-tred steps, extra heavy duty internal spreaders, full set rear horizontals are knee braces, edge bracing systems helps to decrease damage to rail, Glas Mark violator stripes on rails allow ladder to be more visible.

**KNEE CLEARANCE:** NA

**QUANTITY:**

Code	E-074	Quantity
Room_Number		
B215		1
SUB TOTAL		1

**IMAGE:**



**CODE** E-075  
**ITEM:** Standard Hand Truck  
**MANUFACTURER:** U-Line  
**MODEL:** H-1361 10" SOLID WHEELS  
**FINISHES:** Aluminum  
  
**DIMENSIONS:** 14" x 7.5" nose plate / 49" H  
**DESCRIPTION:** Two wheel hand trucks with solid tires.

**KNEE CLEARANCE:** NA

**QUANTITY:**

Code	E-075	Quantity
Room_Number		
B215		1
SUB TOTAL		1

**IMAGE:**



**CODE** E-076  
**ITEM:** Heavy Duty Platform Truck  
**MANUFACTURER:** Global Industries  
**MODEL:** T9C241579  
**FINISHES:** Aluminum  
  
**DIMENSIONS:** 24" x 48" - 600lb Capacity  
**DESCRIPTION:** Heavy duty 24" x 48" platform truck.

**KNEE CLEARANCE:** NA

**QUANTITY:**

Code	E-076	Quantity
Room_Number		
B125		1
SUB TOTAL		1

**IMAGE:**



**CODE** E-078  
**ITEM:** Refridgerator  
**MANUFACTURER:** U-Line  
**MODEL:** Combo Refridgerator/ Freezer 2175rf  
**FINISHES:** Black/ Stainless  
  
**DIMENSIONS:** 24" Model  
**DESCRIPTION:** U-Line's 2175RF boasts ample freezer space to hold ice cream and frozen pizzas while still providing 4.2 cubic feet of refrigerator capacity. Locking.

**KNEE CLEARANCE:** NA

**QUANTITY:**

Code	E-078	Quantity
Room_Number		
B140		1
SUB TOTAL		1

**IMAGE:**



**CODE** E-079  
**ITEM:** Microwave  
**MANUFACTURER:** GE  
**MODEL:** JEB1860DMBB  
**FINISHES:** Black  
  
**DIMENSIONS:** 23- 7/8" x 13- 9/16" x 18 -13/16"  
**DESCRIPTION:** 1.8 Cu. Ft Countertop Microwave Oven

**KNEE CLEARANCE:** NA

**QUANTITY:**

Code	E-079	Quantity
Room_Number		
B206		1
SUB TOTAL		1

**IMAGE:**



**CODE** E-081  
**ITEM:** Chair Dolly  
**MANUFACTURER:** KI  
**MODEL:** MATRIX Chair Dolly FOR Poly Chairs HRDPT  
**FINISHES:** NA  
  
**DIMENSIONS:** 22 -3/8" x 25- 5/8" x 14"  
**DESCRIPTION:** Matrix Chair Dollie for Matrix Chairs (ch-009)- Holds up to 45 chairs per dolly

**KNEE CLEARANCE:** NA

**QUANTITY:**

Code	E-081	Quantity
Room_Number		
C102		14
SUB TOTAL		14

**IMAGE:**



**CODE** E-082  
**ITEM:** Large Narcotic Cabinet  
**MANUFACTURER:** School Health  
**MODEL:** 42021  
**FINISHES:** Beige Steel

**DIMENSIONS:** 16"W x 8"D x 24"H

**DESCRIPTION:** <div>Narcotics Cabinet has double door protection with a key for each door, safes can be set into the wall or outer -wall mounted. Contains 3 adjustable/removable steel shelves. <strong>ITEM MUST BE INSTALLED BY VENDOR.</strong></div>

**KNEE CLEARANCE:** NA

**QUANTITY:**

Code	E-082	Quantity
Room_Number		
B140		1
SUB TOTAL		1

**IMAGE:**



**CODE** E-083  
**ITEM:** First Aid Wall Cabinet  
**MANUFACTURER:** School Health  
**MODEL:** 42026  
**FINISHES:** Heavy Gauge Steel, White Enamel  
  
**DIMENSIONS:** 18"W x 8"D x 27"H  
**DESCRIPTION:** <div>Locked First Aid Wall Cabinets are equipped with key lock, &nbsp;  pull out lower shelf, and a plexi-glass window &nbsp;  in door. <strong>ITEM MUST BE INSTALLED BY VENDOR.</strong></div>

**KNEE CLEARANCE:** NA

**QUANTITY:**

Code	E-083	Quantity
Room_Number		
B140		1
SUB TOTAL		1

**IMAGE:**





**CODE** E-084  
**ITEM:** Emergency Kit  
**MANUFACTURER:** Jackson  
**MODEL:** Emergency Kit  
**FINISHES:** NA

**DIMENSIONS:** NA

**DESCRIPTION:** In 2001, we invited nurses from around the country to participate in a panel discussion. Discussions turned to additional products we could offer. Meri Jackson, President-Elect of the California School Nurses Organization, suggested a kit nurses could have on hand in the event of a sudden emergency. The usefulness of Meri's suggestion became all too apparent the next day, September 11, 2001. We have named the kit the "Jackson Emergency Kit" to honor Meri Jackson and healthcare workers all over the country who came together to help those in need after our national tragedy.

**KNEE CLEARANCE:** NA

**QUANTITY:**

Code	E-084	Quantity
Room_Number		
B140		1
SUB TOTAL		1

**IMAGE:**



**CODE** E-085  
**ITEM:** Maico Audiometer  
**MANUFACTURER:** Maico  
**MODEL:** Ultra Portable Audiometer  
**FINISHES:** NA

**DIMENSIONS:** NA

**DESCRIPTION:** The MA-27 dependability has made it a favorite of school nurses for years. Rugged, all-in-one housing and large, fingertip control knob provides access to a full range of frequencies. Switch between tone, pulse or warble by simply pressing a button. The MA 27 is equipped with a rigid, yet lightweight case with built-in handle and storage compartment. Ample storage holds headphones and other accessories. Air conduction from 250 Hz to 8 kHz. Easy fingertip operation of frequency and hearing level controls.

**KNEE CLEARANCE:** NA

**QUANTITY:**

Code	E-085	Quantity
Room_Number		
B140		1
SUB TOTAL		1

**IMAGE:**



**CODE** E-086  
**ITEM:** Titmus V4 General Testing Model  
**MANUFACTURER:** Titmus  
**MODEL:** V4 Pediatric Testing Model with Perimeter  
**FINISHES:** NA  
  
**DIMENSIONS:** NA  
**DESCRIPTION:** The Titmus V4 vision screening instrument features a compact, lightweight, foldable design for ease of handling, membrane panel for operation, ergonomic design for patient comfort, standardized test illumination and an integrated handle for ease of transport.

**KNEE CLEARANCE:** NA

**QUANTITY:**

Code	E-086	Quantity
Room_Number		
B140		1
SUB TOTAL		1

**IMAGE:**



**CODE** E-087  
**ITEM:** School Health Wheel Chair  
**MANUFACTURER:** School Health  
**MODEL:** Wheelchair 24" with Detachable Elevating Leg Rests  
**FINISHES:** NA  
  
**DIMENSIONS:** NA  
**DESCRIPTION:** Swing-away detachable elevating leg rests featuring padded calf pads. Notched, stainless bar locks the leg rests securely in place. Removable desk-length arms and an 24" wide seat. <br> School Health's most economical wheelchair! Fits comfortably in a budget without sacrificing quality.

**KNEE CLEARANCE:** NA

**QUANTITY:**

Code	E-087	Quantity
Room_Number		
B140		1
SUB TOTAL		1

**IMAGE:**



**CODE** E-088  
**ITEM:** Zoll AED Plus Defibrillator  
**MANUFACTURER:** Zoll  
**MODEL:** AED Plus Unit and Accessories  
**FINISHES:** NA  
  
**DIMENSIONS:** NA  
**DESCRIPTION:** <div>Combines biphasic defibrillation with simplified electrode placement.</div>  
  
<div>Includes: LCD screen showing ECG waveform, voice prompt messages, device advisory messages, elapsed time, shock count and chest compression graph. One set of 123 lithium batteries, CPR-D pads (with 5 year shelf life), accessory kit with CPR barrier mask, scissors, gloves, prep razor, towel, a moist towelette. Basic wall mounting bracket, soft carry case, operator's guide and 5 year limited warranty. <strong>ITEM MUST BE INSTALLED BY VENDOR.</strong></div>

**KNEE CLEARANCE:** NA

**QUANTITY:**

Code	E-088	Quantity
Room_Number		
B140		2
SUB TOTAL		2

**IMAGE:**



**CODE** E-089  
**ITEM:** Welch Allyn Spot Vital Signs  
**MANUFACTURER:** Welch Allyn  
**MODEL:** Spot Vital Signs  
**FINISHES:** NA  
  
**DIMENSIONS:** NA  
**DESCRIPTION:** Mobile stand, BP cuffs, Child preint, Adult, Lg Adult, Thigh- The Spot is lightweight (4 lbs.) with a convenient built-in handle. It is easy to learn and simple to use. The automated Spot Vital Signs unit gives you more time to spend on patient care.

**KNEE CLEARANCE:** NA

**QUANTITY:**

Code	E-089	Quantity
Room_Number		
B140		1
SUB TOTAL		1

**IMAGE:**

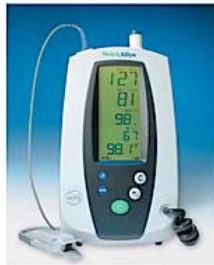

**CODE** E-090  
**ITEM:** Stand Alone Mobile Cabinet w/ Lock  
**MANUFACTURER:** School Health  
**MODEL:** 24598  
**FINISHES:** Putty

**DIMENSIONS:** 30"W x 24"D x 72"H

**DESCRIPTION:** Features 22 gauge steel, patented heavy-duty caster base, recessed three point locking handle, three adjustable shelves and includes a bottom shelf. Welded steel construction and durable finish, allows for 40-70% more storage space than your standard size cabinets.

**KNEE CLEARANCE:** NA

**QUANTITY:**

Code	E-090	Quantity
Room_Number		
B140		1
SUB TOTAL		1

**IMAGE:**



**CODE** E-091  
**ITEM:** Stand alone wall mounted Digital Height Rod  
**MANUFACTURER:** School Health  
**MODEL:** 58096  
**FINISHES:** NA

**DIMENSIONS:** 43"-79" H

**DESCRIPTION:** <div>The Dectecto Stadiometer delivers quick and accurate readings, &nbsp;measures up to 6' 7&quot; with automatic height viewing on the remote display. The stadiometer display measures 1&quot; and contains LCD screen and 5 digit, cable length measures 69&quot;, &nbsp;takes 6 AA Alkaline batteries and weights 8.2lbs. <strong>ITEM MUST BE INSTALLED BY VENDOR.</strong></div>

**KNEE CLEARANCE:** NA

**QUANTITY:**

Code	E-091	Quantity
Room_Number		
B140		1
SUB TOTAL		1

**IMAGE:**





**CODE** E-092  
**ITEM:** Faucet Mounted Eye Wash System  
**MANUFACTURER:** EyeSafe  
**MODEL:** AC42155  
**FINISHES:** NA

**DIMENSIONS:** NA

**DESCRIPTION:** EyeSafe &nbsp;faucet-mounted eyewashes convert any faucet into an emergency eyewash station without interfering with normal faucet operation. An EyeSafe™ unit can be installed at any sink, close to where accidents might occur. In an emergency, unit is quickly located and activated, and provides an unlimited supply of portable water for rinsing the user's eyes.

**KNEE CLEARANCE:** NA

**QUANTITY:**

Code	E-092	Quantity
Room_Number		
B140		1
SUB TOTAL		1

**IMAGE:**



**CODE** E-093  
**ITEM:** Shredder  
**MANUFACTURER:** School Specialty- Swingline  
**MODEL:** ShredDaster GLX3055  
**FINISHES:** NA  
  
**DIMENSIONS:** 25-1/4"x23-1/4"x38-1/4", 16" wide-mouth paper throat  
**DESCRIPTION:** Ideal for high volume departments, includes a jamstopper electronics for multi-person use. Shreds through credit cards, staples, and 30 sheets of paper into a 55 gallon bin.

**KNEE CLEARANCE:** NA

**QUANTITY:**

Code	E-093	Quantity
Room_Number		
B126		1
SUB TOTAL		1

**IMAGE:**



**CODE** E-094  
**ITEM:** Walkie Talkies  
**MANUFACTURER:** Colony Hardware Supply Co. Inc  
**MODEL:** 2 Watt- 2-Channel UHFC Job Site Radio  
**FINISHES:** NA  
  
**DIMENSIONS:** NA  
**DESCRIPTION:** MUST BE CONFIGURED TO INTERFACE WITH EXISTING RADIO PROGRAMMING-  
 RESPONSIBILITY OF VENDOR TO ENSURE CORRECT DEVICE BEFORE PURCHASING.

**KNEE CLEARANCE:** NA

**QUANTITY:**

Code	E-094	Quantity
Room_Number		
B126		12
SUB TOTAL		12

**IMAGE:**



**CODE** E-095  
**ITEM:** Chair Dollies-Immersive  
**MANUFACTURER:** Avarte  
**MODEL:** Funktus  
**FINISHES:** Stainless Steel  
  
**DIMENSIONS:**  
**DESCRIPTION:** To Coordinate with Avarte Functus Immersive theater Chair

**KNEE CLEARANCE:** NA

**QUANTITY:**

Code	E-095	Quantity
Room_Number		
B122		10
SUB TOTAL		10



**CODE** E-096  
**ITEM:** Stereo Microscopes  
**MANUFACTURER:** Dissecting Microscopes.com  
**MODEL:** du028aed0m  
**FINISHES:** NA

**DIMENSIONS:** NA

**DESCRIPTION:** Rechargeable Battery Powered LED Stereo Binocular Microscope - Turret Style Selectable Magnification. Bright and Clear 3-D Stereoscopic Images. Perfect for Studying Plant-Animal-Mineral Specimens. Great for Gemologists, Collectors, Engravers, Document Examiners, Students, Schools, Etc. Great Economical Price! Priced Much Lower than Competition! Fixed Magnification: 10x or 30x, wide Field 10x Eyepiece Set . 45 Degree Inclined Binocular Head, Rotatable 360 Degrees. ,focusing Adjustment Range: 47mm . Includes Rubber Eye Guards for Blocking Stray Light, 110 VAC Power Requirement, 5 yr warranty.

**KNEE CLEARANCE:** NA

**QUANTITY:**

Code	E-096	Quantity
Room_Number		
B118		1
SUB TOTAL		1

**IMAGE:**



**CODE** E-097  
**ITEM:** Human Life Skeleton  
**MANUFACTURER:** Carolina  
**MODEL:** 46875  
**FINISHES:** Plastic

**DIMENSIONS:** NA

**DESCRIPTION:** Plastic. First quality. Articulated to show normal posture. Extremities are removable. Detachable skull has calvarium cut and contains 32 teeth. Lower jaw is spring held. Includes plastic dust cover and Human Anatomy Manual. Skeleton is mounted by means of a metal rod extending from the sacrum. With quadropod base and casters. Detachable skulls have cut calvaria and spring-held jaws. Extremities are removable for individual study, anatomically correct specimens, correctly articulated to show normal posture.

**KNEE CLEARANCE:** NA

**QUANTITY:**

Code	E-097	Quantity
Room_Number		
B118		1
SUB TOTAL		1

**IMAGE:**

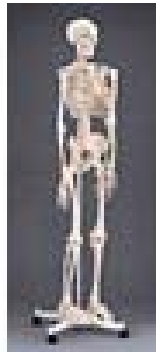

**CODE** E-098  
**ITEM:** Human Eye Model  
**MANUFACTURER:** Carolina  
**MODEL:** 566944  
**FINISHES:** NA

**DIMENSIONS:** 9 × 9 × 15 cm

**DESCRIPTION:** 3B® & Denoyer-Geppert are priced somewhat lower than Somso®, these models are nevertheless extremely well-crafted. They offer a realistic choice for general-college level anatomy education. 3B® products simulate human structures as precisely as possible. Denoyer-Geppert models are a bit stylized with modest exaggeration of some primary anatomical landmarks.

**KNEE CLEARANCE:** NA

**QUANTITY:**

Code	E-098	Quantity
Room_Number		
B118		1
SUB TOTAL		1

**IMAGE:**



**CODE** E-099  
**ITEM:** Human Ear Model  
**MANUFACTURER:** Carolina  
**MODEL:** 566965  
**FINISHES:** Polymer

**DIMENSIONS:** 32 × 19 × 13 cm

**DESCRIPTION:** Altay®. About 3× life size. Pinna, external ear canal, tympanum, auditory ossicles, Eustachian tube, vestibular apparatus, and cochlea are shown in exquisite detail along with neural, osseous, and vascular structures.<br><br>The middle and inner ear components are removable for individual examination. Mounted on a durable polymer base. Numbered key is included

**KNEE CLEARANCE:** NA

**QUANTITY:**

Code	E-099	Quantity
Room_Number		
B118		1
SUB TOTAL		1

**IMAGE:**

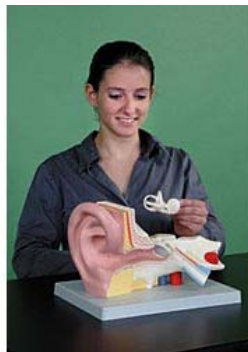



**CODE** E-100  
**ITEM:** Human Heart Model  
**MANUFACTURER:** The Therapy Connection at HPMS Inc.  
**MODEL:** ANA-G10  
**FINISHES:** NA  
  
**DIMENSIONS:** 3.5"L x 4"H  
**DESCRIPTION:** A life-size model depicting atrium cordis, ventricles of the heart and cardiac valves. Dissects into 2 parts. Removable from stand.

**KNEE CLEARANCE:** NA

**QUANTITY:**

Code	E-100	Quantity
Room_Number		
B118		1
SUB TOTAL		1

**IMAGE:**



**CODE** E-101  
**ITEM:** Animal Skeleton Snake  
**MANUFACTURER:** MilesCo Scientific  
**MODEL:** 805F  
**FINISHES:** NA

**DIMENSIONS:** 4 1/8" x 13 3/4"

**DESCRIPTION:** The Poisonous Snake skeleton is beautifully displayed in a wooden base with acrylic cover. It almost seems as if it might just slither away! (Agkistrodon halys, Halys Pit Viper)

**KNEE CLEARANCE:** NA

**QUANTITY:**

Code	E-101	Quantity
Room_Number		
B118		1
SUB TOTAL		1

**IMAGE:**



**CODE** E-102  
**ITEM:** Long Handed Nets 1  
**MANUFACTURER:** Foster and Smith Aquatics  
**MODEL:** CE-19192  
**FINISHES:** Aluminum handle, mesh netting

**DIMENSIONS:** 12" x 5" , reaches 24"-60"

**DESCRIPTION:** Remove excess organic materials such as leaves on a regular basis to prevent accumulation. This not only allows your filtration to work more efficiently but also prevents potential equipment damage due to clogs. A little bit of effort alleviates extra burden placed on costly pond equipment and ensures years of proper operation. Pond skimmer nets are ideal for removing small or manageable amount of leaves and debris.

**KNEE CLEARANCE:** NA

**QUANTITY:**

Code	E-102	Quantity
Room_Number		
B118		1
SUB TOTAL		1

**IMAGE:**

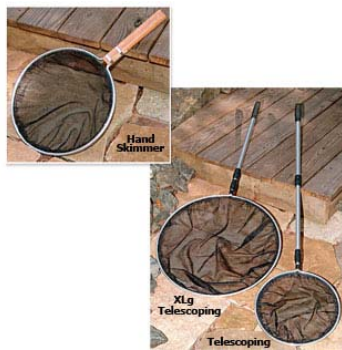

**CODE** E-103  
**ITEM:** Short Handed Strainers  
**MANUFACTURER:** Foster and Smith Aquatics  
**MODEL:** CE-19193  
**FINISHES:** Mesh net, wooden handle

**DIMENSIONS:** 8" L x 12" x 3" D

**DESCRIPTION:** Shallow skillet-style nets with extra wide collection areas for regular spot maintenance. Remove floating debris before it settles, decays, or clogs vital filtration systems. Hand Skimmer cleans up shorelines, waterfalls, and streams with ease, and its wooden grip with rust-proof frame will last season after season. Standard or extra wide Telescoping models extend your reach out to 5 feet, featuring lightweight but sturdy aluminum poles that retract to less than half that size for convenient storage.

**KNEE CLEARANCE:** NA

**QUANTITY:**

Code	E-103	Quantity
Room_Number		
B118		1
SUB TOTAL		1

**IMAGE:**



**CODE** E-104  
**ITEM:** Long Handed Nets 2  
**MANUFACTURER:** Nature Pavillion- Adventure Products  
**MODEL:** B001PF51PI  
**FINISHES:** Aluminum handle, mesh netting  
  
**DIMENSIONS:** 11" sq net, 30" extendable handle that goes up to 57"  
**DESCRIPTION:** Pro Insect Net with Telescoping Handle-Designed for the professional to effectively capture land bound insects. Lightweight mesh will not cause damage or injury to specimens.

**KNEE CLEARANCE:** NA

**QUANTITY:**

Code	E-104	Quantity
Room_Number		
B118		1
SUB TOTAL		1

**IMAGE:**



**CODE** E-105  
**ITEM:** Trowels  
**MANUFACTURER:** No Thyme Productins-Children's Quality Garden  
**MODEL:** Z55564  
**FINISHES:** Stainless steel, birch wood handle

**DIMENSIONS:** 8.5"L x 2.5"W x 2"H

**DESCRIPTION:** Bright hand on this Trowel with stainless Steel tines and birch handle. Made by Garden Works so you know it is quality US made. The only one you will ever need to buy no matter how many children you have. &nbsp;Always use with adult supervision.

**KNEE CLEARANCE:** NA

**QUANTITY:**

Code	E-105	Quantity
Room_Number		
B118		1
SUB TOTAL		1

**IMAGE:**



**CODE** E-106  
**ITEM:** Pig Lung Demo Kit  
**MANUFACTURER:** Ward's Natural Science  
**MODEL:** 81 V 2003  
**FINISHES:** NA

**DIMENSIONS:** 20"L x 8"W x 3 1/2"H

**DESCRIPTION:** Cast from an actual specimen, all of the intricate structural detail usually only seen on a real dissected specimen can clearly be seen on the model of a nearly full-term fetal pig.<br><br>It features all internal organs and major arteries and veins found along the body cavity, head, and neck. In addition, the heart, lungs, stomach, liver, and intestines are removable as a single unit so students can study the deeper organs and vasculature. <br><br>One kidney is sectioned to show renal circulation. Made of a unique material for flexibility.

**KNEE CLEARANCE:** NA

**QUANTITY:**

Code	E-106	Quantity
Room_Number		
B118		1
SUB TOTAL		1

**IMAGE:**



**CODE** E-107  
**ITEM:** Digital Thermometers  
**MANUFACTURER:** Science Kit  
**MODEL:** WW01765M35  
**FINISHES:** NA

**DIMENSIONS:** 3 3/4"L x 2 5/8"W x 5/8"H.

**DESCRIPTION:** Because it's battery-powered, you can use the thermometer/hygrometer for virtually any application requiring careful monitoring of temperature and humidity. The large digital display also recalls minimum/maximum temperature and humidity readings over any time period. Temperature range: 32–122°F (0– 50°C) with accuracy of ±2°F or 1°C and a 1° resolution for both °F and °C; Relative humidity range: 20–99% with an accuracy of ±3% and a resolution of 1%.

**KNEE CLEARANCE:** NA

**QUANTITY:**

Code	E-107	Quantity
Room_Number		
B118		1
SUB TOTAL		1

**IMAGE:**





**CODE** E-108  
**ITEM:** Animal & Plant Life Cycle Cards  
**MANUFACTURER:** Teaching Supply Store  
**MODEL:** LER2928  
**FINISHES:** NA

**DIMENSIONS:** NA

**DESCRIPTION:** Science in motion! Seeing leads to understanding. Set of 18 lenticular cards illustrating key vocabulary and concepts regarding plant and animal life cycles. For grades 1st and up.

**KNEE CLEARANCE:** NA

**QUANTITY:**

Code	E-108	Quantity
Room_Number		
B118		1
SUB TOTAL		1

**IMAGE:**



**CODE** E-109  
**ITEM:** Solar System Model  
**MANUFACTURER:** American Educational Products  
**MODEL:** B0017Y7MB8  
**FINISHES:** NA

**DIMENSIONS:** 25.8 x 10 x 14.5

**DESCRIPTION:** Colorful 3-D model provides graphic evidence of Copernicus' theory. Base supports a 6 in. diameter sun (15.2cm) surrounded by nine planets, the outermost of which is 16.5 in. (41.9cm) from the sun. Learn to identify the planets as well as their sizes, distances, and the speeds at which they travel.

**KNEE CLEARANCE:** NA

**QUANTITY:**

Code	E-109	Quantity
Room_Number		
B118		1
SUB TOTAL		1

**IMAGE:**



**CODE** E-110  
**ITEM:** Weather Station  
**MANUFACTURER:** Davis Vantage Pro 2  
**MODEL:** DO-86403-03  
**FINISHES:** NA

**DIMENSIONS:** 9.5 in W x 6 in H x 1.5 in D

**DESCRIPTION:** The Davis Vantage Pro2 weather stations have greater accuracy and doubles the transmitting distance than the original Vantage Pro. Stations measure and display barometric pressure, indoor and outdoor temperature and humidity, heat index, dew point, wind direction and speed, wind chill, rain fall, time, date, forecasts, moon phase, sunrise, and sunset. Weather messages scroll across the bottom of the digital display for more detailed information.

**KNEE CLEARANCE:** NA

**QUANTITY:**

Code	E-110	Quantity
Room_Number		
B118		1
SUB TOTAL		1

**IMAGE:**



**CODE** E-111  
**ITEM:** Weather Reporting Camera  
**MANUFACTURER:** Pentax  
**MODEL:** E167559  
**FINISHES:** NA

**DIMENSIONS:** 4-1/2" x 2-1/4" x 1-1/8"

**DESCRIPTION:** No matter where your travels take you, be ready to capture memories with the WG-1 digital camera. Its ultra-sturdy design is waterproof to 33', shockproof to drops up to 5', and coldproof to temperatures down to 14F, so it can withstand the harshest conditions—meaning you can get shots like never before. All with crystal-clear, 14 megapixel quality, and safely stored on 97MB of internal memory.

**KNEE CLEARANCE:** NA

**QUANTITY:**

Code	E-111	Quantity
Room_Number		
B118		1
SUB TOTAL		1

**IMAGE:**



**CODE** E-112  
**ITEM:** Weather Reporting Board  
**MANUFACTURER:** Shop.com  
**MODEL:** AMED409  
**FINISHES:** NA

**DIMENSIONS:** 35" x 45"

**DESCRIPTION:** The Weather Watch Board is a realistic tool for teaching students about the complexity of weather conditions. Complete with a NOAA Weather Radio, students can have access to the most up-to-date weather information available. The 35 x 45 vacuum-formed board comes complete with a set of 14 study prints that help in the interpretation of observable weather conditions. Local map is not included. Includes Teachers Guide. Batteries not included.

**KNEE CLEARANCE:** NA

**QUANTITY:**

Code	E-112	Quantity
Room_Number		
B118		1
SUB TOTAL		1

**IMAGE:**



**CODE** E-113  
**ITEM:** Camera  
**MANUFACTURER:** Canon  
**MODEL:** PowerShot ELPH 100 HS digital  
**FINISHES:** Blue metal

**DIMENSIONS:** 3.7"W x 2.2"H x 0.8"D

**DESCRIPTION:** This sleek and stylish PowerShot ELPH 100 HS digital camera is what you need to add that creative edge. It's packed with powerful technologies that make this memory-making tool a great value. The camera possesses a 12.1-megapixel high sensitivity CMOS sensor, a 4X optical zoom, a wide angle 28mm equivalent lens and a 3.0-inch LCD screen for easy viewing and scrolling through menus.

**KNEE CLEARANCE:** NA

**QUANTITY:**

Code	E-113	Quantity
Room_Number		
B118		1
SUB TOTAL		1

**IMAGE:**



**CODE** E-114  
**ITEM:** Work Bench  
**MANUFACTURER:** Wood Craft  
**MODEL:** 146469  
**FINISHES:** Birch Wood

**DIMENSIONS:** 68" x 23" x 3.5"

**DESCRIPTION:** The Nordic Plus series gives you the size you need at a price you can afford. The bench top is constructed in hard Nordic Birch. The amazing versatility of vice location permits left or right handed use, clamping on both ends or dual clamping on the front. All of the wood in the bench is FSC certified which guarantees forestry renewal. The hard Nordic birch top is built to last for a lifetime of normal use. Supplied with four steel bench dogs with a plastic coating to protect your edge tools. There is a double row of 3/4" clamping holes working from each of the four vise locations, giving an endless opportunity to clamp your work! All three benches are 33-1/2" high, 19-5/8" wide, have a 1 1/8" top thickness at the center and a 2 3/4" thick skirt. Vises 29"-33"

**KNEE CLEARANCE:**

**QUANTITY:**

Code	E-114	Quantity
Room_Number		
B118		2
SUB TOTAL		2

**IMAGE:**



**CODE** E-115  
**ITEM:** Tool Storage  
**MANUFACTURER:** Sears  
**MODEL:** 30-WRK-400RB  
**FINISHES:** Powdercoat steel red/black

**DIMENSIONS:** 32"H x 48"W

**DESCRIPTION:** Over 10.5 square feet of metal pegboard storage space that will not deteriorate. Magnetic pegboard panels that accept both standard pegboard pegs as well as the included secure engagement slotted hooks, brackets, and shelves. The metal pegboard's attractive, scratch resistant finish wipes clean for long-lasting aesthetic appeal. Installation is easy and requires no framework due to the metal pegboard's pre-formed flange which space the panel face off of the wall or stud. &nbsp;Kit includes mounting hardware and storage shelf, 1 year warranty.

**KNEE CLEARANCE:** NA

**QUANTITY:**

Code	E-115	Quantity
Room_Number		
B118		1
SUB TOTAL		1

**IMAGE:**

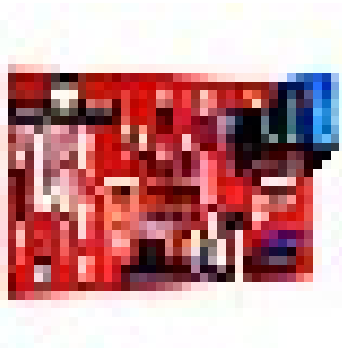



**CODE** E-116  
**ITEM:** Storage Bins  
**MANUFACTURER:** NA  
**MODEL:** NA  
**FINISHES:** Blue plastic  
**DIMENSIONS:** NA  
**DESCRIPTION:** Storage Bins

**KNEE CLEARANCE:** NA

**QUANTITY:**

<b>Code</b>	<b>E-116</b>	<b>Quantity</b>
<b>Room_Number</b>		
B118		1
<b>SUB TOTAL</b>		1

**IMAGE:**



**CODE** E-117  
**ITEM:** Floor Lamp  
**MANUFACTURER:** Meijer- Adesso  
**MODEL:** 65010122  
**FINISHES:** Black

**DIMENSIONS:** Adjustable height from 43" - 71", Shade size: 11"L x 4-1/2"D, Flexible gooseneck - 5-1/2"L

**DESCRIPTION:** Now you can have stylish design and green living all in the same piece with the Adesso Search Gooseneck Floor Lamp. The flexible gooseneck allows the light to be directed in any direction and the height to be adjusted from 43" to 71". Takes a 13W compact fluorescent light bulb (included) that gives light equivalent to a standard 60W light bulb. Coordinates with the Search Gooseneck Desk Lamp from Adesso (sold separately).

**KNEE CLEARANCE:** NA

**QUANTITY:**

Code	E-117	Quantity
Room_Number		
B118		1
SUB TOTAL		1

**IMAGE:**



**CODE** E-118  
**ITEM:** Water & Sand Table  
**MANUFACTURER:** Daycare Furniture Shop.com- Jonti-Craft  
**MODEL:** JC048  
**FINISHES:** Acrylic tub, frame made of Baltic Birch

**DIMENSIONS:** 37L x 23W x 20H Inches

**DESCRIPTION:** The See-Thru Sand-N-Water Table is the perfect size for a toddler. Provides ultimate splash control with the clear, tuff, nine-inch deep acrylic tub complete with a matching see-thru acrylic activity cover. Frame is made of Baltic Birch with locking casters. Drain with valve is included. Ready to assemble.

**KNEE CLEARANCE:** NA

**QUANTITY:**

Code	E-118	Quantity
Room_Number		
B118		2
SUB TOTAL		2

**IMAGE:**



**CODE** E-119  
**ITEM:** Rolling Cart  
**MANUFACTURER:** ScripHesso  
**MODEL:** 2720012  
**FINISHES:** Stainless Steel

**DIMENSIONS:** 19"W x 17"D x 20"H

**DESCRIPTION:** Make transporting anything a lot easier with this stainless steel 2 shelf rolling cart. This cart gives you flexibility within any type of work environment. Shelves have stain-resistant surface with a 1/4" lip, so spills are contained to a small area. You can tackle a wide variety of jobs from the warehouse, to office or anywhere you need a sturdy cart. Easy to assemble.

**KNEE CLEARANCE:** NA

**QUANTITY:**

Code	E-119	Quantity
Room_Number		
B118		1
SUB TOTAL		1

**IMAGE:**



**CODE** E-120  
**ITEM:** Weather Station Software  
**MANUFACTURER:** Data Logger Software  
**MODEL:** 6510USB  
**FINISHES:** NA

**DIMENSIONS:** 9" x 6" x 2"

**DESCRIPTION:** WeatherLink with standard data logger, is software and a data connection the connects your Davis weather station to your PC using a USB port. The data logger stores information even when your computers is turned off or not connected. Weather software that links your Davis weather station to your computer. More weather data, view weather information that is not on the console. Comes with a data logger that fits in all Vantage Pro and Vue systems. User-Selectable storage interval, choose 1, 5, 10, 15, 30, 60 or 120 minutes . Weather Website, create a weather website or post weather conditions to a LAN.

**KNEE CLEARANCE:** NA

**QUANTITY:**

Code	E-120	Quantity
Room_Number		
B118		1
SUB TOTAL		1

**IMAGE:**



**CODE** E-121  
**ITEM:** Weather Station Mounting Tripod  
**MANUFACTURER:** Davis  
**MODEL:** 07716  
**FINISHES:** Steel

**DIMENSIONS:** Includes two 3 foot poles, used together make a 5.8 foot pole

**DESCRIPTION:** Mounting Tripod is for use with Daviss Wireless vantage Pro2, and Vantage Pro Weather Stations. The Mounting Tripod simplifies installation. The tripod supports the sensor array, and features an adjustable foot pad which enables mounting on any surface: flat, inclined, or level. The anemometer extension tube can be used to elevate the anemometer in installations where wind flow obstruction is a concern. Brackets at the base of each leg tilt to mount on your roof or uneven terrain. Made of galvanized steel.

**KNEE CLEARANCE:** NA

**QUANTITY:**

Code	E-121	Quantity
Room_Number		
B118		1
SUB TOTAL		1

**IMAGE:**



**CODE** E-122  
**ITEM:** Work Table  
**MANUFACTURER:** Amazon  
**MODEL:** B001TMEX7E  
**FINISHES:** Stainless Steel  
  
**DIMENSIONS:** 49"L x 24"W x 35"H

**DESCRIPTION:** Stainless steel table work surface has curved edges for safety. Heavy duty adjustable chrome plated steel shelf. Chrome plated 1.5" diameter poles with leveling feet. Suitable for work, kitchen, restaurants, and food preparation.

**KNEE CLEARANCE:** NA

**QUANTITY:**

Code	E-122	Quantity
Room_Number		
B118		1
SUB TOTAL		1

**IMAGE:**



**CODE** E-123  
**ITEM:** Poster Cabinet  
**MANUFACTURER:** Tiger Supplies  
**MODEL:** 3042-5DB-SDG: Cabinet, CKUB: Wood caster kit, 3042-CB-SDG :Flat file  
**FINISHES:** White Birchwood , aluminum handles  
  
**DIMENSIONS:** Cabinet measures:47"W x 16-5/8"H x 33"D, Casters are 3", Flat file measures: 30" x 42"  
**DESCRIPTION:** SMI 5 drawer stores 30" x 42" sheets with drawer guides that are steel drawer guides. Cabinets are stackable and contain 5 drawers.<br><br>Casters come 4 to a kit and include 2 with brakes.<br><br>3042-5DB-SDG Cabinet is priced at \$475.99<br>CKUB Casters are priced at \$109.99<br>3042-CB-SDG is priced at \$119.99

**KNEE CLEARANCE:** NA

**QUANTITY:**

Code	E-123	Quantity
Room_Number		
B118		1
SUB TOTAL		1

**IMAGE:**





**CODE** E-124  
**ITEM:** Grow Lab  
**MANUFACTURER:** Gardening With Kids  
**MODEL:** 10-1214E  
**FINISHES:** NA

**DIMENSIONS:** 52"x23"x73"

**DESCRIPTION:** Maximizes growing potential with 16 sq ft of growing space. Accommodates up to 144 3-1/2" pots. Includes 8 Gro-Lux™ wide-spectrum tubes. Has 4 independently adjustable light fixtures. Includes 2 programmable timers, one for each tier. Comes with many more accessories, including a climate control tent for the top tier and 2 books: GrowLab: A Complete Guide to Gardening in the Classroom, and the GrowLab curriculum, GrowLab: Activities for Growing Minds. Rolls smoothly on heavy-duty, locking casters. Has a 1-year unconditional warranty

**KNEE CLEARANCE:** NA

**QUANTITY:**

Code	E-124	Quantity
Room_Number		
B118		1
SUB TOTAL		1

**IMAGE:**



**CODE** E-125  
**ITEM:** Planting Center  
**MANUFACTURER:** AllGreenHouses.Com  
**MODEL:** JU1117  
**FINISHES:** Cedar Wood

**DIMENSIONS:** 32" H x 60" W x 20" D

**DESCRIPTION:** Accessories make your greenhouse more functional and will increase your enjoyment and productivity. The Greenhouse Cedar Potting Table features two levels with plenty of working space for your potting needs. This table spans five feet long.

**KNEE CLEARANCE:** NA

**QUANTITY:**

Code	E-125	Quantity
Room_Number		
B118		1
SUB TOTAL		1

**IMAGE:**



**CODE** E-127  
**ITEM:** Rug 1  
**MANUFACTURER:** Worthington Direct  
**MODEL:** 34176  
**FINISHES:** NA

**DIMENSIONS:** 8'-3" X 11'-8" , Oval

**DESCRIPTION:** The Pond Carpet has cool, calming colors and simple, broad design create the perfect home for Storytime, Quietime and all your group gatherings. The extremely durable Kidply (R) backing makes this the ideal carpet for early childhood centers with anti-wrinkling and creasing properties, increased sound and thermal insulation performance, double-stitched serged edges. Carpets for kids is so confident in their product they offer a lifetime wear warranty on all their carpets. Lifetime Anti-Microbial Protection. Lifetime Anti-Static Fiber. Double-stitched serged edges. Carpet stain protection. Assists in Allergen Particle Control. Meets NFPA 253, Class I Firecode Requirements

**KNEE CLEARANCE:** NA

**QUANTITY:**

<b>Code</b>	<b>E-127</b>	<b>Quantity</b>
<b>Room_Number</b>		
B118		1
<b>SUB TOTAL</b>		1

**IMAGE:**



**CODE** E-128  
**ITEM:** Rug 2  
**MANUFACTURER:** Worthington Direct-Joy Carpets  
**MODEL:** 50107  
**FINISHES:** NA

**DIMENSIONS:** 7'-7", Round

**DESCRIPTION:** Earthworks Carpet stimulate discussion about the natural gifts that our planet provides for all of us. Lifetime limited wear warranty. Lifetime patented anti-microbial protection. Approved and registered by the FDA and EPA. Lifetime anti-static fiber. High twist 100% nylon. Class 1 Flammability rating. Bound and double-stitched serging. Made in the USA.

**KNEE CLEARANCE:** NA

**QUANTITY:**

Code	E-128	Quantity
Room_Number		
B118		1
SUB TOTAL		1

**IMAGE:**



**CODE** E-129  
**ITEM:** Demo Storage Cart  
**MANUFACTURER:** Hertz Furniture-Diversified Woodcrafts  
**MODEL:** DVR-4402  
**FINISHES:** Solid Oak, Oak Veneer

**DIMENSIONS:** 36"W x 24"D x 36"H

**DESCRIPTION:** These stations are designed to utilize space along walls where they can stand alone or be ganged together. Durable solid oak and oak veneer construction combined with a protective aqua lacquer finish ensure years of reliable service. Locking cabinet. One full adjustable shelf. Rolls easily on 4" ball-bearing locking swivel casters. Top is 1 1/4" ChemGuard. 25 yr warranty,

**KNEE CLEARANCE:** NA

**QUANTITY:**

Code	E-129	Quantity
Room_Number		
B118		1
SUB TOTAL		1

**IMAGE:**



**CODE** E-130  
**ITEM:** Demo Lab Table  
**MANUFACTURER:** Hertz Furniture-Diversified Woodcrafts  
**MODEL:** DVR-4502  
**FINISHES:** Chemical Resistant Laminate surface, ,medium density fiberboard

**DIMENSIONS:** 24"W x 36"L x 30"H

**DESCRIPTION:** These Mobile Demo Lab Carts were designed for the transportation of equipment and supplies. The carts roll easily on four factory-installed, 3" ball-bearing swivel casters with brakes. 1-1/4" ChemGuard top.Solid oak construction.The 2-1/4" square legs are securely fastened to the 4-1/2" high apron with factory-installed 5/16" hanger bolts through the heavy-duty 13-gauge steel corner braces.Includes leg stretchers and auxiliary oak plywood shelf.Four factory-installed, 3" ball-bearing swivel casters with brakes.Clear acrylic finish.

**KNEE CLEARANCE:** NA

**QUANTITY:**

Code	E-130	Quantity
Room_Number		
B118		2
SUB TOTAL		2

**IMAGE:**



**CODE** E-133  
**ITEM:** Pallet Jack  
**MANUFACTURER:** Grainger  
**MODEL:** BTL2300U  
**FINISHES:** Red

**DIMENSIONS:** 61 8/18" over all length, fork height lowered-2-9/10", fork height raised-7-3/4", fork length-

**DESCRIPTION:** Hand Pallet Truck, Hydraulic, Load Capacity 5000 Lb, steel construction. 2 load carrying  
barrings, pivots 180 degrees, with 10 grease fittings. Wheel & roller material-  
polyurethane.

**KNEE CLEARANCE:** NA

**QUANTITY:**

Code	E-133	Quantity
Room_Number		
B215		1
SUB TOTAL		1

**IMAGE:**



**CODE** E-135  
**ITEM:** Rolling Wire Shelves  
**MANUFACTURER:** Global Industrial  
**MODEL:** 188208  
**FINISHES:** Steel Finish in Chrome

**DIMENSIONS:** 54"H x 48"W x 14"D

**DESCRIPTION:** Includes 4 posts with leveling feet, 4 shelves and snap-on sleeves to secure shelves to posts - everything needed to build unit shown. Electroplated nickel-chrome is durable, chip resistant and attractive for use in retail display.

**KNEE CLEARANCE:** NA

**QUANTITY:**

Code	E-135	Quantity
Room_Number		
B118		3
SUB TOTAL		3

**IMAGE:**





**CODE** E-136  
**ITEM:** Wire Shelving  
**MANUFACTURER:** Global Industries  
**MODEL:** 188240  
**FINISHES:** Steel finish in Chrome

**DIMENSIONS:** 54"H x 48"W x 24"D

**DESCRIPTION:** Includes 4 posts with leveling feet, 4 shelves and snap-on sleeves to secure shelves to posts - everything needed to build unit shown. Electroplated nickel-chrome is durable, chip resistant and attractive for use in retail display.

**KNEE CLEARANCE:** NA

**QUANTITY:**

Code	E-136	Quantity
Room_Number		
B118		1
SUB TOTAL		1

**IMAGE:**



**CODE** E-137  
**ITEM:** Wire Shelving Covers  
**MANUFACTURER:** Alera  
**MODEL:** W59SL4824  
**FINISHES:** Clear Plastic

**DIMENSIONS:** 24" x 48"

**DESCRIPTION:** Alera; wire shelving offers an endless array of home, restaurant and business solutions. Crystal clear and easy to clean liners fit over matching-sized wire shelves. Ideal for small item storage. Global Product Type: Shelving Parts-Shelf Liner; Shelving. Comes in a pack of 4.

**KNEE CLEARANCE:** NA

**QUANTITY:**

Code	E-137	Quantity
Room_Number		
B118		4
SUB TOTAL		4

**IMAGE:**



**CODE** E-138  
**ITEM:** Wire Shelving Casters  
**MANUFACTURER:** Global Industries  
**MODEL:** CS18491299.95  
**FINISHES:** Polyurethane  
  
**DIMENSIONS:** 5"D x 1-1/4"W  
**DESCRIPTION:** Swivel caster with 2 brakes

**KNEE CLEARANCE:** NA

**QUANTITY:**

Code	E-138	Quantity
Room_Number		
B118		16
SUB TOTAL		16

**IMAGE:**



**CODE** E-139  
**ITEM:** Recycle Bins  
**MANUFACTURER:** Global Industries-Akro-Mils  
**MODEL:** 662122  
**FINISHES:** Grey Plastic

**DIMENSIONS:** 23-3/4"X15-3/4"X16-1/8"

**DESCRIPTION:** Create a complete storage system or use individually to keep a variety of components and inventory stored compactly. These cost effective, reusable containers are ideal for manufacturing, transporting and storing products. Inter-stackable, reinforced straight wall design allows you to maximize storage space by cubing in trucks and on pallets. Ergonomically designed containers feature comfortable grip hand holds on all four sides for quick and easy pick-up. OPEN MESH allows for increased visibility and ventilation. SOLID construction keeps even the smallest items in and provides a smooth interior surface. Sold in carton quantities of 2.

**KNEE CLEARANCE:** NA

**QUANTITY:**

Code	E-139	Quantity
Room_Number		
B118		3
SUB TOTAL		3

**IMAGE:**



**CODE** E-140  
**ITEM:** Laptop/ Document Camera Cart  
**MANUFACTURER:** Balt  
**MODEL:** BAL-27519  
**FINISHES:** Teak Finish

**DIMENSIONS:** 18" x 30" x 40.25"

**DESCRIPTION:** Balt's Laptop Caddy Presentation Cart has four shelves that let you keep your laptop, projector and printer at just the right levels. A sturdy steel frame supports the laminate shelves, and grommet holes help you organize cords and cables. Wheel this sturdy steel cart from room to room on three-inch casters. Available with gray or teak laminate shelving. Opt for a four- or seven-outlet electrical unit or a locking cabinet to protect valuable equipment when not in use.

**KNEE CLEARANCE:** NA

**QUANTITY:**

Code	E-140	Quantity
Room_Number		
A101		1
A106		1
A107		1
A112		1
A113		1
A118		1
A119		1
A122		1
A125		1
A130		1
B118		1
B138		1
C108		1
C111		1
C112		1
A201		1
A202		1
A203		1
A204		1
A205		1
A206		1
A207		1
A208		1
A214		1
A215		1
B201		1
B202		1
B204		1
B205		1
SUB TOTAL		29

IMAGE:



**CODE** E-141  
**ITEM:** Lecturn  
**MANUFACTURER:** AmpliVox  
**MODEL:** SN3130  
**FINISHES:** Maple with Satin Anodized Aluminum

**DIMENSIONS:** 26.75" x 16.75" x 49"

**DESCRIPTION:** The high-density polyethylene (a plastic also found in the marine industry) construction of black bottom and reading shelf complement the styling of the black anodized aluminum uprights. The look is completed by the Hardrock Maple Formica panels that snap into the aluminum uprights in seconds without the need of tools. The acrylic shelf located in the back is an ideal spot to keep a glass of water or laser pointer nearby.

**KNEE CLEARANCE:** NA

**QUANTITY:**

Code	E-141	Quantity
Room_Number		
C101		2
SUB TOTAL		2

**IMAGE:**



**CODE** E-142  
**ITEM:** Refridgerator  
**MANUFACTURER:** GE  
**MODEL:** GTH18HCCWW-GE Energy Star 18.1 Cu. Ft. Top-Freezer Refridgerator  
**FINISHES:** White  
  
**DIMENSIONS:** 28" x 32 3/8" x 67 3/8"  
**DESCRIPTION:** 1 Fixed with Tall Bottle Storage, 3 Adjustable with Gallon Storage.

**KNEE CLEARANCE:**

**QUANTITY:**

Code	E-142	Quantity
Room_Number		
B133		1
B206		1
SUB TOTAL		2

**IMAGE:**

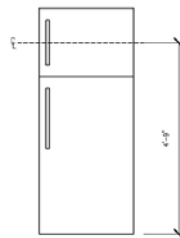
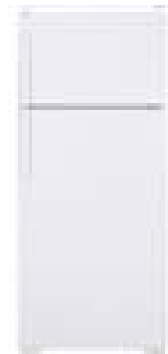



**CODE** E-143  
**ITEM:** Terrarium Set Up  
**MANUFACTURER:** Exotic Fish and Corals  
**MODEL:** Varies  
**FINISHES:** NA

**DIMENSIONS:** 48" X 24" X 24"

**DESCRIPTION:** Tank -delux black silicon / 5 bags flora bedding / 1 pond structure/ 1 humidifiers system fogger/ 1 misting unit with controler / 1 backing of bark Board / 3 auto timers / 1 humidity/ tmeperature gage / 1 UV Lighting System with timers/ 1 understank heating mat controlled / 1 corner waterfall with pump/ 2 reptile deco plants with rock structures. TANK MUST BE SET UP & INSTALLED BY VENDOR. PRICING MUST INCLUDE TRAINING.

**KNEE CLEARANCE:** NA

**QUANTITY:**

Code	E-143	Quantity
Room_Number		
C118		1
SUB TOTAL		1

**IMAGE:**



**CODE** E-144  
**ITEM:** Camcarts  
**MANUFACTURER:** Cambro  
**MODEL:** 1826LTC  
**FINISHES:** blue

**DIMENSIONS:** 18" X 26"

**DESCRIPTION:** <div>Use to hold hot or cold bulk food stored on trays, sheet pans or in food boxes. Durable polyethylene and thick foam insulation retain safe food temperatures. Sturdy plastic, rust-proof latches are secured into molded-in mounting plates. Molded-in handle on the back for easy maneuvering. All carts have 6" (15,2 cm) casters: 2 front fixed, 2 rear swivel, 1 with brake. Includes Vollrath package of 12- 17 3/4" x 25 3/4" x 1" D &nbsp;aluminum alloy sheet pans model no. 9001.</div>

**KNEE CLEARANCE:** N/A

**QUANTITY:**

Code	E-144	Quantity
Room_Number		
C118		3
SUB TOTAL		3

**IMAGE:**



**CODE** F-001  
**ITEM:** 4 Drawer Vertical Cabinet  
**MANUFACTURER:** Hon  
**MODEL:** H314  
**FINISHES:** Metal paint color Putty  
**DIMENSIONS:** 52- 1/8"H x 15"W  
**DESCRIPTION:** 4 Drawer letter, no locks, high drawer sides hold hanging folders without use of hangrails, premium quality construction, interchangeable core and removable locks for security.

**KNEE CLEARANCE:** NA

**QUANTITY:**

**IMAGE:**



**CODE** F-002  
**ITEM:** File Shuttle & Companion File  
**MANUFACTURER:** School Specialty  
**MODEL:** 1329876 & 090050  
**FINISHES:** Black

**DIMENSIONS:** Cart- 15.625" x 18" x 25.625", Companion File- 17" x 14" x 11"

**DESCRIPTION:** Hanging file cart-all steel construction to hold up to 100lbs of heavy files. Holds up to one companion file, sturdy lower rack for more files and reference material. Comes in black.<br><br>
 Companion File- large capacity file has easy lift handle and transparent lid, holds letter or legal size papers up to a 40lb weight limit. Comes in black.<br><br>
 1329876 is priced at \$69.99<br>
 090050 is priced at \$49.49

**KNEE CLEARANCE:** NA

**QUANTITY:**

Code	F-002	Quantity
Room_Number		
C104		1
SUB TOTAL		1

**IMAGE:**



**CODE** F-003  
**ITEM:** Wood Lateral  
**MANUFACTURER:** First Office  
**MODEL:** 17-3858LF4 Smart Series  
**FINISHES:** Cherry Veneer  
  
**DIMENSIONS:** 37.875" x 21.8125 x 57.75"  
**DESCRIPTION:** Lateral File has 4 drawers and contains a central locking with anti-tilt mechanism and adjustable levelers. Weights 280 lbs.

**KNEE CLEARANCE:** NA

**QUANTITY:**

Code	F-003	Quantity
Room_Number		
B126		4
SUB TOTAL		4

**IMAGE:**





**CODE** S-002  
**ITEM:** Classroom Bookcase  
**MANUFACTURER:** Vanerum Stelter  
**MODEL:** SH.AR.SL.DS.362436  
**FINISHES:** Natural Cherry Wood Laminate  
  
**DIMENSIONS:** 36" x 24" x 36"  
**DESCRIPTION:** Bookcase, unfinished back, adjustable leevlers.

**KNEE CLEARANCE:** N/A

**QUANTITY:**

Code	S-002	Quantity
Room_Number		
A101		3
A106		3
A107		3
A112		3
A113		3
A118		3
A119		3
A130		3
B138		6
C112		8
B206		6
<b>SUB TOTAL</b>		<b>44</b>

**IMAGE:**



**CODE** S-003  
**ITEM:** Big Book Display  
**MANUFACTURER:** Brodart  
**MODEL:** VL 015 001  
**FINISHES:** Clear Premium Oak

**DIMENSIONS:** 30" H x 34" W x 25" D

**DESCRIPTION:** Two-sided children's book displayer with markerboard features 6 overlapping shelving for displays on one side, whiteboard on the other on casters. Handy 2 level spaces below markerboard. 5-yr warranty.

**KNEE CLEARANCE:** NA

**QUANTITY:**

Code	S-003	Quantity
Room_Number		
A101		1
A106		1
A107		1
A112		1
A113		1
A118		1
A119		1
A130		1
B138		1
SUB TOTAL		9

**IMAGE:**





**CODE:** S-004  
**ITEM:** Mobile Cubby Unit  
**MANUFACTURER:** Vanerum Stelter  
**MODEL:** SP.ST.18472-01  
**FINISHES:** Cherry Laminate  
  
**DIMENSIONS:** 48" x 20" x 32"  
**DESCRIPTION:** Mobile Cubby unit

**KNEE CLEARANCE:** N/A

**QUANTITY:**

Code	S-004	Quantity
Room_Number		
A101		3
A106		3
A107		3
A112		3
A113		3
A118		3
A119		3
A130		3
B138		3
A201		3
A202		3
A203		3
A204		3
A205		3
A206		3
A214		3
A215		3
B201		3
B202		3
B204		3
B205		3
<b>SUB TOTAL</b>		<b>63</b>

**IMAGE:**

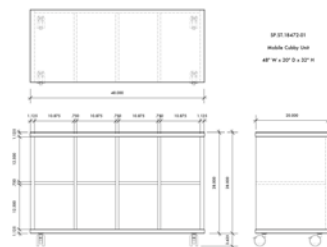

**CODE** S-005  
**ITEM:** Cubby w/ Clear Trays  
**MANUFACTURER:** School Specialty- Korner for Kids  
**MODEL:** 1335325- cubby, 203638- tray  
**FINISHES:** Birch Veneer panels  
  
**DIMENSIONS:** 47-3/4 "L x 14-1/4"D x 42"H- Cubby, 13"L x 10- 1/2"W x 5"H.-Tray  
**DESCRIPTION:** Holds up to 24 trays, dado construction adds strength, no exposed fasteners.INCLUDE TRAYS:203638.

**KNEE CLEARANCE:** N/A

**QUANTITY:**

Code	S-005	Quantity
Room_Number		
C111		1
SUB TOTAL		1

**IMAGE:**



**CODE** S-006  
**ITEM:** Storage Unit  
**MANUFACTURER:** Vanerum Stelter  
**MODEL:** ST.FO.SC.4S.301847  
**FINISHES:** Black

**DIMENSIONS:** 18"D x 30"L x 47"H, Shelving units are 18" Deep

**DESCRIPTION:** Folio closed storage is fully spot-welded construction, single walled construction with double reinforced bottom. Shelves adjust in increments of 1/2", standard black 1/4 turn locks, doors have soft, self close hinges.

**KNEE CLEARANCE:** N/A

**QUANTITY:**

Code	S-006	Quantity
Room_Number		
C111		1
SUB TOTAL		1

**IMAGE:**



**CODE** S-007  
**ITEM:** Rolling Utility Cart  
**MANUFACTURER:** School Specialty  
**MODEL:** 678771  
**FINISHES:** Thermoplastic

**DIMENSIONS:** 17"W x 31"L x 33"H, Shelves measure 4 -1/4" Deep.

**DESCRIPTION:** Small and durable cart, holds up to 500lbs / 250lbs per shelf, 4 casters- 2swivel and other 2 are fixed.

**KNEE CLEARANCE:** N/A

**QUANTITY:**

Code	S-007	Quantity
Room_Number		
C101		2
C104		2
SUB TOTAL		4

**IMAGE:**



**CODE** S-008  
**ITEM:** Gym/PE Storage  
**MANUFACTURER:** Uline  
**MODEL:** H-1528  
**FINISHES:** N/A

**DIMENSIONS:** 72" x 24" x 72"

**DESCRIPTION:** Wide span storage rack is quick and easy to assemble, boltless shelves make it easy to snap into place, quick to assemble, and adjust at 1- 1/2" increments. Additional shelves and posts available, store heavy, bulky items with access on all four sides. Shelves measure to 36" x 24", with 6 shelves per unit, unit made of 14 gauge steel, shelf capacity limit 1,000lbs. (Per Pair)

**KNEE CLEARANCE:** N/A

**QUANTITY:**

Code	S-008	
Room_Number		Quantity
C102		6
C105		4
SUB TOTAL		10

**IMAGE:**



**CODE** S-009  
**ITEM:** Storage Cabinet  
**MANUFACTURER:** Vegas  
**MODEL:** 3-7236SW2  
**FINISHES:** Cherry Laminate  
  
**DIMENSIONS:** 36" x 24" x 72.5"  
**DESCRIPTION:** Storage Wardrobe, unfinished back, adjustable leevlers.

**KNEE CLEARANCE:** NA

**QUANTITY:**

Code	S-009	Quantity
Room_Number		
A126		3
B114		4
B119		2
C104		2
SUB TOTAL		11

**IMAGE:**



**CODE** S-010  
**ITEM:** Flat File Cabinet  
**MANUFACTURER:** Paramount  
**MODEL:** T9A506826GY  
**FINISHES:** Gray

**DIMENSIONS:** 46" x 36"

**DESCRIPTION:** Premium, 5 drawer flat file cabinets keep valuable documents and blueprints flat and curl-free with hinged paper depressors. Blueprint storage cabinets are made with sturdy steel with internal reinforcements for added strength. The heavy gauge steel base permits stacking for added storage in minimal space. These blueprint filing systems feature an easy-glide precision drawer runners and a scratch resistant furniture grade finish. Drawer fronts have label holders for easy identification and chrome plated drawer pulls.

**KNEE CLEARANCE:** NA

**QUANTITY:**

Code	S-010	Quantity
Room_Number		
B206		2
SUB TOTAL		2

**IMAGE:**



**CODE** S-011  
**ITEM:** 2 Drawer  
**MANUFACTURER:** First Office  
**MODEL:** Vegas- 36" Lateral File Cabinet 3-3622LF2  
**FINISHES:** Cherry Laminate  
  
**DIMENSIONS:** 36" x 22" x 30"  
**DESCRIPTION:** 36" Laminated 4 drawer lateral file cabinet.

**KNEE CLEARANCE:** NA

**QUANTITY:**

Code	S-011	Quantity
Room_Number		
B140		1
SUB TOTAL		1

**IMAGE:**





**CODE** S-012  
**ITEM:** Mobile Bookcases  
**MANUFACTURER:** First Office  
**MODEL:** Vegas- 30" Bookcases 3-3648BC  
**FINISHES:** Cherry Laminate  
**DIMENSIONS:** 36" x 14" x 29.875"  
**DESCRIPTION:** Vegas- 30" Bookcases 3-3648BC

**KNEE CLEARANCE:** NA

**QUANTITY:**

**IMAGE:**



**CODE** S-013  
**ITEM:** Safe  
**MANUFACTURER:** School Specialty-Sentry Safe  
**MODEL:** 1121619  
**FINISHES:** NA  
  
**DIMENSIONS:** 14-13/16"L x 11-7/8" W x 19-21/32" H

**DESCRIPTION:** Electronic Safe is fire rated 2 hrs up to 1850 degrees fahrenheit, holds a-4 size papers, binders, folders, safe is water resistant. Features LCD electronic lock with blacklit keypad, programmable pin access, tubular key lock w/ 7 live locking bolts. Has metal handle, pull out file rack, multiposition drawer, key rack, & door pocket to store small items, bolt down hardware, weights 211 lbs.

**KNEE CLEARANCE:** NA

**QUANTITY:**

Code	S-013	Quantity
Room_Number		
B126		1
SUB TOTAL		1

**IMAGE:**



**CODE** S-014  
**ITEM:** Garment Racks  
**MANUFACTURER:** Wenger  
**MODEL:** Rack N Roll Garment Storage  
**FINISHES:** Black

**DIMENSIONS:** 6' Model

**DESCRIPTION:** This is the easy, smart way to move your bulky garments, gowns, coats, and uniforms from storage to rehearsal or performance for a fast change. The Rack 'n Roll garment rack is heavy-duty enough to hold a full wardrobe but designed so efficiently it can easily roll through standard doorways or elevators. Now you can keep your valuable investments off the floor when you need to move them – so no more soiled or torn costumes. Garment racks are available in both a 4' and 6' model. And they're so well designed, they can be easily disassembled without tools.

**KNEE CLEARANCE:** NA

**QUANTITY:**

Code	S-014	Quantity
Room_Number		
B123		4
SUB TOTAL		4

**IMAGE:**



**CODE:** S-015  
**ITEM:** Classroom Bookcase  
**MANUFACTURER:** Vanerum Stelter  
**MODEL:** SH.AR.SL.S.361236  
**FINISHES:** Cherry Laminate  
  
**DIMENSIONS:** 36"H x 36"W x 12"D  
**DESCRIPTION:** Bookcase, unfinished back, adjustable leevlers.

**KNEE CLEARANCE:** N/A

**QUANTITY:**

<b>Code</b>	<b>S-015</b>	<b>Quantity</b>
<b>Room_Number</b>		
A101		3
A106		3
A107		3
A113		3
A118		3
A119		3
A122		3
A123		6
A130		3
B107		2
B107A		2
B111		6
B132		2
B134		6
A201		3
A202		3
A203		3
A204		3
A205		3
A206		3
A214		3
A215		3
B201		3
B202		3
B204		3
B205		3
B214		5
A112		3
<b>SUB TOTAL</b>		<b>92</b>

IMAGE:



**CODE** S-016  
**ITEM:** Wooden Shelving  
**MANUFACTURER:** First Office  
**MODEL:** Vegas  
**FINISHES:** Cherry Laminate  
  
**DIMENSIONS:** 36" X 14" X 72.5 "  
**DESCRIPTION:** Bookcase, unfinished back, adjustable leevlers.

**KNEE CLEARANCE:** N/A

**QUANTITY:**

<b>Code</b>	<b>S-016</b>	
<b>Room_Number</b>		<b>Quantity</b>
B132		2
B140		1
B141		1
<b>SUB TOTAL</b>		<b>4</b>

**IMAGE:**



**CODE** S-017  
**ITEM:** Wall Hung Shelving  
**MANUFACTURER:** Metro  
**MODEL:** 12WS32C  
**FINISHES:** Chrome

**DIMENSIONS:** 36" x 12" x 21"

**DESCRIPTION:** Used to create wall-mounted shelving units with 12" or 18" (305 or 460mm) regular Erecta Shelf® shelves of any length. Models are available to accommodate from one to five shelves. Each mount consists of shelf support and mounting brackets. Wall bolts or screws not included; they must be selected according to type of wall.

**KNEE CLEARANCE:** N/A

**QUANTITY:**

**IMAGE:**



**CODE** S-018  
**ITEM:** Classroom Bookcase  
**MANUFACTURER:** Vanerum Stelter  
**MODEL:**  
**FINISHES:** Cherry Laminate  
  
**DIMENSIONS:** 36"H x 36"W x 18"D  
**DESCRIPTION:** Bookcase, unfinished back, adjustable leevlers.

**KNEE CLEARANCE:** N/A

**QUANTITY:**

<b>Code</b>	<b>S-018</b>	<b>Quantity</b>
<b>Room_Number</b>		
A201		4
A202		5
A203		4
A204		5
A205		4
A206		5
A214		2
A215		3
B201		3
B202		2
B204		2
B205		3
<b>SUB TOTAL</b>		<b>42</b>

**IMAGE:**



**CODE** T-001  
**ITEM:** Round Table  
**MANUFACTURER:** Smith System  
**MODEL:** 04330  
**FINISHES:** Wild Cherry Top, Black Edging and Frame

**DIMENSIONS:** 21"-30"H x 48"Diameter

**DESCRIPTION:** 48" Round Husky Table, 79 LBS, Durable and roomy laminated work surface measuring 1 1/4". Work surface is fused to a 45-lb particle board core with backer sheet. 17-gauge steel tube legs measure 1 3/4" in diameter. Telescoping legs with an interior sliding action to adjust on 1" centers, available in two adjustable heights of 15"-24" or 21"-30". Legs attached to desktop with pre-installed or easy-to-assemble mounting brackets. Foot sock made of high intensity nylon glides. Bumper edge (3/8" thickness) with rounded corners & edges to protect the skin & floor from scratches. Bumper edge fastened every 6" to 8" to keep it intact.

**KNEE CLEARANCE:** ADA Minimum clearance required: 30" w x 19" d x 27" h

**QUANTITY:**

Code	T-001	Quantity
Room_Number		
A101		5
A106		5
A107		5
A112		5
A113		5
A118		5
A119		5
A130		5
B107A		1
B138		5
C112		1
<b>SUB TOTAL</b>		<b>47</b>

**IMAGE:**

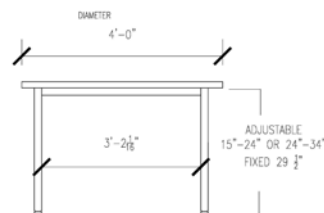

**CODE:** T-002  
**ITEM:** Trapezoid Table  
**MANUFACTURER:** Jonti-Craft Inc- Rainbow Accents  
**MODEL:** 6438JCA210  
**FINISHES:** Laminate top, thermo-fused edgebanding.

**DIMENSIONS:** 24"W x 48"L x 24"-31"H

**DESCRIPTION:** Kydz Activity table has no room for germs because of the thermo-fuzes edgebanding. 1 1/8" thick available in several colors, laminate table top, table available in 3 heights; toddler, elementary and adult. Upper leg powder coated to match edgeband color, minimal assembly, dual-screw leg adjustability system that is extra safe, legs adjust in 1" increments. Swivel glides nylon based prevent rusting, 5 yr Warranty.

**KNEE CLEARANCE:** ADA Minimum clearance required: 30" w x 19" d x 27" h

**QUANTITY:**

Code	T-002	Quantity
Room_Number		
A101		2
A106		2
A107		2
A112		2
A113		2
A118		2
A119		2
A122		4
A130		2
B118A		4
B134		2
B138		2
A207		2
A208		2
B214		2
<b>SUB TOTAL</b>		<b>34</b>

**IMAGE:**

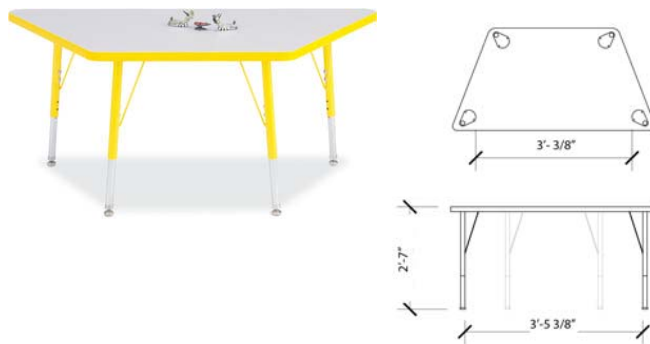

**CODE** T-003  
**ITEM:** Kidney Table  
**MANUFACTURER:** Virco  
**MODEL:** 48C00P72  
**FINISHES:** Walnut Top, Black Edge Band

**DIMENSIONS:** 36" L x 72" W x 26"-34"H

**DESCRIPTION:** Half Moon Cooperative Learning Activity Table, 1 1/8" Thick Laminate Top, Virco's fantastic 4000 Series Activity Tables are utility classroom activity tables that encourage group and interactive learning. Model 48COOP72 is a kidney shaped table with adjustable height legs. They can be used in classrooms, workrooms, training rooms or even as an economical replacement for computer tables. Contemporary colors and two adjustable height configurations make them a big hit with students and schools.

**KNEE CLEARANCE:** ADA Minimum clearance required: 30" w x 19" d x 27" h

**QUANTITY:**

Code	T-003	Quantity
Room_Number		
A101		1
A106		1
A107		1
A112		1
A113		1
A118		1
A119		1
A130		1
B134		1
B138		1
A207		1
A208		1
A214		1
A215		1
B201		1
B202		1
B204		1
B205		1
SUB TOTAL		18

**IMAGE:**

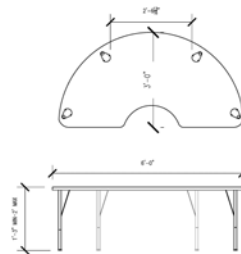



**CODE** T-005  
**ITEM:** Adjustable Height Table  
**MANUFACTURER:** Hertz Furniture-Diversified Woodcrafts  
**MODEL:** DVR-8102  
**FINISHES:** Chemical Resistant Laminate surface, medium density fiberboard.

**DIMENSIONS:** 48"W x 24"D x adjustable height 27-39"H

**DESCRIPTION:** 1 1/4" chemical resistant ChemGuard desktop. Tables adjust easily - without tools - from 27" to 39" high. Great ADA Solution. Raise only one end for an incline table for physics. 500-lb. weight capacity. 4 1/2" high solid oak frame with exposed metal corner braces. Adjustable glides (standard) or locking casters (optional). Optional casters are 2.5" high and table with casters would start at 29.25" high. Wheelchair accessible - ADA compliant.

**KNEE CLEARANCE:** ADA Minimum clearance required: 30" w x 19" d x 27" h

**QUANTITY:**

Code	T-005	Quantity
Room_Number		
B118		12
SUB TOTAL		12

**IMAGE:**



**CODE:** T-006  
**ITEM:** Computer Tables  
**MANUFACTURER:** Smith Systems  
**MODEL:** Flex Station Table 01378  
**FINISHES:** Cherry Laminate Top, Black Edging

**DIMENSIONS:** 24D" x 72W" x 24-32" H

**DESCRIPTION:** Flex Computer stations by Smith System provide a complete and organized work environment. Lab stations are perfect for any kind of official setting. Steel wire management trays conceal wires and maintain a clean look on work area. Computer desks come in different color combinations and sizes. Each table also comes with Color matched plastic end caps. The adjustable height feature makes it more versatile. Brilliant ABS adjustable chairs match well with these computer stations.

**KNEE CLEARANCE:** ADA Minimum clearance required: 30" w x 19" d x 27" h

**QUANTITY:**

Code	T-006	Quantity
Room_Number		
A101		2
A106		2
A107		2
A112		2
A113		2
A118		2
A119		2
A122		1
A130		2
B134		1
B138		2
C108		2
C111		2
C112		2
A201		2
A202		2
A203		2
A204		2
A205		2
A206		2
A207		1
A208		1
A214		2
A215		2
B201		2
B202		2
B204		2
B205		2
SUB TOTAL		52

IMAGE:



**CODE:** T-007  
**ITEM:** ADA Compliant Tables  
**MANUFACTURER:** Smith Systems  
**MODEL:** Flex Station  
**FINISHES:** Cherry Laminate Top with Black Edge Banding and Platinum Legs

**DIMENSIONS:** 24" x 36" x 24-32"H

**DESCRIPTION:** The Flex Station is truly flexible, with an oversize top that's perfect for today's project learning environments. Choose from single student or two student stations available in five sizes. High pressure laminate surface, bumper edge molding, adjustable legs, and wire tray.

**KNEE CLEARANCE:** ADA Minimum clearance required: 30" w x 19" d x 27" h

**QUANTITY:**

Code	T-007	Quantity
Room_Number		
A101		1
A106		1
A107		1
A112		1
A113		1
A118		1
A119		1
A122		1
A130		1
B114		1
B134		1
B138		1
C108		1
C111		1
C112		1
A201		1
A202		1
A203		1
A204		1
A205		1
A206		1
A207		1
A208		1
A214		1
A215		1
B201		1
B202		1
B204		1
B205		1
SUB TOTAL		29



IMAGE:

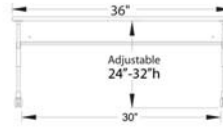
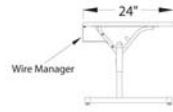

**CODE** T-008  
**ITEM:** Technology Tables  
**MANUFACTURER:** Vanerum Stelter  
**MODEL:** TB.TRG.ST.3624.A.7  
**FINISHES:** Cherry laminate top, metal legs

**DIMENSIONS:** 24"D x 36"W x 26"-35" Adjustable height

**DESCRIPTION:** Trios I-C Leg has a 1.125" table top thickness. Standard core construction is 44lb. density particle board. 2" radius corners standard. 2mm vinyl edgeband applied with medium-viscosity, high-melt adhesive. Stretcher bars available for additional support. Greenguard certified High Pressure Laminate. Oven baked epoxy/polyester powder coat finish, Steel construction, Metal to metal inserts available for added strength and High-impact plastic end caps.

**KNEE CLEARANCE:** ADA Minimum clearance required: 30" w x 19" d x 27" h

**QUANTITY:**

Code	T-008	Quantity
Room_Number		
A125		25
SUB TOTAL		25

**IMAGE:**



**CODE** T-009  
**ITEM:** Round Conference Table  
**MANUFACTURER:** First Office  
**MODEL:** Vegas 48" Round: 3-48rt2 with 2 Metal T Bases spaced for min. 30" Clear Between  
**FINISHES:** Cherry Laminate / rd Pewter  
**DIMENSIONS:** 48" DIA  
**DESCRIPTION:** Vegas 48" Round; Round: 3-48rt2 with 2 Metal T Bases spaced for min.

**KNEE CLEARANCE:** ADA Minimum clearance required: 30" w x 19" d x 27" h

**QUANTITY:**

Code	T-009	Quantity
Room_Number		
A123		1
SUB TOTAL		1

**IMAGE:**

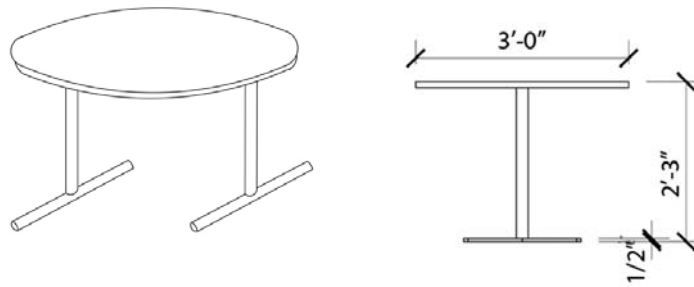

**CODE** T-010  
**ITEM:** Round Student Tables  
**MANUFACTURER:** Smith Systems  
**MODEL:** 04335 60" Round Table  
**FINISHES:** Cherry Laminate Top with Persian Blue Edge Molding

**DIMENSIONS:** 60" x 21"-30 " H

**DESCRIPTION:** Adjustable legs add flexibility and meet height requirements for K-adult, adjusting from 15" to 30" high. Legs are 1-3/4" diameter 17-gauge steel tubing. Telescoping legs adjust on 1" centers. Legs are secured to top with mounting brackets pre-installed in tops. Leg base is heavy-gauge stamped steel plate with formed steel rod welded to 1-3/4" round 17-gauge tube. Table tops are 1-1/4" thick, with a high-pressure laminate bonded to a 45-lb. particle board core with backer sheet. Tops also feature a 3/8" thick bumper edge with rounded corners and edges, protecting the surface and students from bumps and scratches.

**KNEE CLEARANCE:** ADA Minimum clearance required: 30" w x 19" d x 27" h

**QUANTITY:**

Code	T-010	Quantity
Room_Number		
C108		2
A201		2
A202		2
A203		2
A204		2
A205		2
A206		2
A214		1
A215		1
B201		1
B202		1
B204		1
B205		1
SUB TOTAL		20

**IMAGE:**

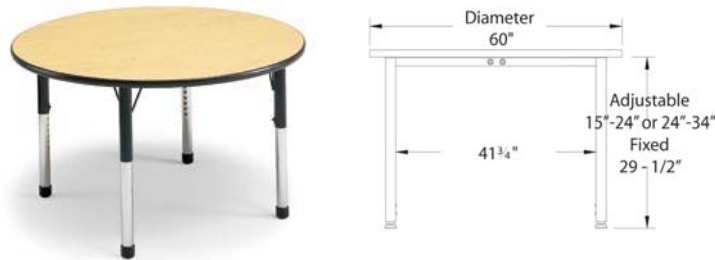

**CODE** T-011  
**ITEM:** Rectangular Tables  
**MANUFACTURER:** TMC Furniture  
**MODEL:** TR3060L10  
**FINISHES:** Cherry

**DIMENSIONS:** 30"W X 60"L X 29"H

**DESCRIPTION:** Part of the Algonquin Collection featuring simple, elegant lines, the traditional-looking Algonquin Table is distinguished by its solid wood, squared post legs. A durable, tasteful and inviting table design that compliments any interior, the Algonquin is available in several sizes and is customizable with grommets and power/data accessories

**KNEE CLEARANCE:** ADA Minimum clearance required: 30" w x 19" d x 27" h

**QUANTITY:**

Code	T-011	Quantity
Room_Number		
B123		3
B206		4
SUB TOTAL		7

**IMAGE:**

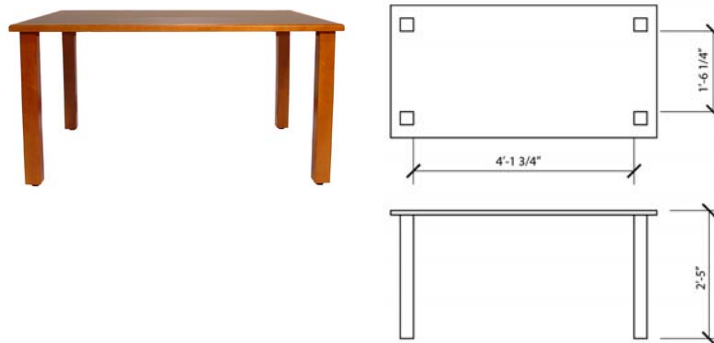

**CODE** T-012  
**ITEM:** Round Café Table w/ Stools  
**MANUFACTURER:** Midwest  
**MODEL:** Mobile Stool Unit- Round  
**FINISHES:** Wild Cherry Laminate Top with Blue Edge Banding / Chrome Legs

**DIMENSIONS:** 60" DIA x 27"H

**DESCRIPTION:** The Midwest Round Mobile Stool Cafeteria Table creates a comfortable, durable and safe environment for students, faculty and guests. The obstacle-free entry design allows kids and adults to easily reach their seats, while the round shape makes it easy for students to converse. Reinforced plastic stools withstand the wear and tear of daily use. Gravity locks and Midwest's exclusive Easy Clean feature secure table open or closed for easy movement and cleanup.

**KNEE CLEARANCE:** ADA Minimum clearance required: 30" w x 19" d x 27" h

**QUANTITY:**

Code	T-012	Quantity
Room_Number		
C122		22
SUB TOTAL		22

**IMAGE:**



**CODE** T-013  
**ITEM:** Round Café Table- ADA Compliant  
**MANUFACTURER:** Midwest  
**MODEL:** Mobile Stool Unit- Round ADA Version  
**FINISHES:** Wild Cherry Laminate Top with Blue Edge Banding / Chrome Legs

**DIMENSIONS:** 60" DIA x 27"H

**DESCRIPTION:** The Midwest Round Mobile Stool Cafeteria Table creates a comfortable, durable and safe environment for students, faculty and guests. The obstacle-free entry design allows kids and adults to easily reach their seats, while the round shape makes it easy for students to converse. Reinforced plastic stools withstand the wear and tear of daily use. Gravity locks and Midwest's exclusive Easy Clean feature secure table open or closed for easy movement and cleanup. LEAVE ONE STOOL LOCATION ABSENT TO ACCOMMODATE WHEELCHAIR ACCESS

**KNEE CLEARANCE:** ADA Minimum clearance required: 30" w x 19" d x 27" h

**QUANTITY:**

Code	T-013	Quantity
Room_Number		
C122		6
SUB TOTAL		6

**IMAGE:**



**CODE** T-014  
**ITEM:** Art Tables  
**MANUFACTURER:** School Specialty- Allied Plastics  
**MODEL:** 561794  
**FINISHES:** Maple laminate

**DIMENSIONS:** 42"W x 60"L x 30"H

**DESCRIPTION:** Superior classroom or lab tables! Tops designed with solid resinous core and a chemical-resistant black laminated surface. Features include wall-saving, black vinyl bumper molding and 3 4 x 5 wide hardwood aprons. Legs of 2 1/4" square solid hardwood attach sturdily into steel corner brackets on apron with 2 heavy-duty bolts. Floor-protecting black vinyl boots complete the design. Easy assembly simply attach the legs. 5-yr. limited warranty. Ship wt. 75 lbs. FOB Jacksonville, FL. Made in USA. DS

**KNEE CLEARANCE:** ADA Minimum clearance required: 30" w x 19" d x 27" h

**QUANTITY:**

Code	T-014	Quantity
Room_Number		
C111		6
SUB TOTAL		6

**IMAGE:**





**CODE** T-015  
**ITEM:** Small Round Conference Table  
**MANUFACTURER:** First Office  
**MODEL:** Vegas 36" Conference Table- Round : 3-36RT2 / MXB-32  
**FINISHES:** Cherry Laminate Top with RD (Pewter) Legs  
**DIMENSIONS:** 36" DIA X 30"  
**DESCRIPTION:** Vegas 36" Conference Table- Round : 3-36RT2 / MXB-32

**KNEE CLEARANCE:** ADA Minimum clearance required: 30" w x 19" d x 27" h

**QUANTITY:**

**IMAGE:**

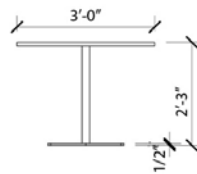

**CODE** T-016  
**ITEM:** Boat Shaped Conference Table  
**MANUFACTURER:** First Office  
**MODEL:** Vegas 96" Boat Shaped Conference Table 3-9642BT2 with Elipse Base Legs (2) EB-24  
**FINISHES:** Cherry Laminate with RD Pewter  
  
**DIMENSIONS:** 96" X 42" X 30"  
**DESCRIPTION:** Vegas 96" Boat Shaped Conference Table 3-9642BT2 with Elipse Base Legs (2) EB-24

**KNEE CLEARANCE:** ADA Minimum clearance required: 30" w x 19" d x 27" h

**QUANTITY:**

Code	T-016	Quantity
Room_Number		
B114		1
B139		1
SUB TOTAL		2

**IMAGE:**

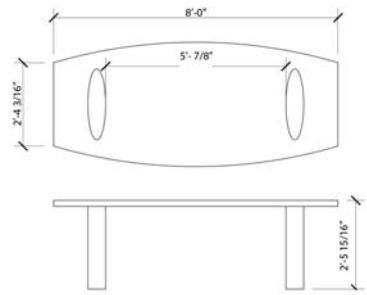

**CODE** T-017  
**ITEM:** Library Tables  
**MANUFACTURER:** TMC Furniture  
**MODEL:** Kestrel Table- Square  
**FINISHES:** Solid Wood Legs- Cherry with Solid Wood Edge and Laminate Top: TBD  
**DIMENSIONS:** 48" X 48" X 30"  
**DESCRIPTION:** Tapered solid wood legs provide a classic look to the sleek Kestrel table.

**KNEE CLEARANCE:** ADA Minimum clearance required: 30" w x 19" d x 27" h

**QUANTITY:**

Code	T-017	Quantity
Room_Number		
B101		6
SUB TOTAL		6

**IMAGE:**



**CODE** T-018  
**ITEM:** Small Work Table  
**MANUFACTURER:** Highland Products- Virco  
**MODEL:** 412-1067  
**FINISHES:** Cherry Laminate

**DIMENSIONS:** 36" x 36", 22"-30" adjustable height

**DESCRIPTION:** 1.125" thick high pressure laminate particleboard top with backing sheet. Standard legs that enable a 22" - 30" top height adjustment range. &nbsp;It offers an option of steel-based glides. Chrome finish lower legs

**KNEE CLEARANCE:** ADA Minimum clearance required: 30" w x 19" d x 27" h

**QUANTITY:**

**IMAGE:**

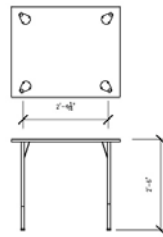

# Room by Room Matrix

ROOM NUMBER	ROOM NAME	QTY	Type	Type Comments	ELIGIBILITY	
<b>A101</b>						
<b>Kindergarten</b>						
		1	A-001	Wastebasket	<input type="checkbox"/>	<input type="checkbox"/>
		1	A-002	Classroom Flag	<input type="checkbox"/>	<input type="checkbox"/>
		1	A-008	Pencil Sharpener	<input type="checkbox"/>	<input type="checkbox"/>
		1	A-009	Pre K & K Rug	<input type="checkbox"/>	<input type="checkbox"/>
		1	A-018	Folder & Tray Cubby Mail Slots	<input type="checkbox"/>	<input type="checkbox"/>
		1	A-019	Wheasel	<input type="checkbox"/>	<input type="checkbox"/>
		1	A-020	1/2 Nursery Block Set	<input type="checkbox"/>	<input type="checkbox"/>
		1	A-061	Recycle Container	<input type="checkbox"/>	<input type="checkbox"/>
		24	A-063	Mini-White Boards	<input type="checkbox"/>	<input type="checkbox"/>
		1	A-064	Map Pack 1-Pre K-K	<input type="checkbox"/>	<input type="checkbox"/>
		12	A-145	Large Book Baskets	<input type="checkbox"/>	<input type="checkbox"/>
		12	A-146	Medium Book Basket	<input type="checkbox"/>	<input type="checkbox"/>
		35	CH-002	K + 1st Grade Small Chairs	<input type="checkbox"/>	<input type="checkbox"/>
		1	CH-006	Teacher Chair	<input type="checkbox"/>	<input type="checkbox"/>
		2	CH-007	Teacher Reading Chair	<input type="checkbox"/>	<input type="checkbox"/>
		1	D-003L	Teacher's Classroom Desk	<input type="checkbox"/>	<input type="checkbox"/>
		1	E-140	Laptop/ Document Camera Cart	<input type="checkbox"/>	<input type="checkbox"/>
		3	S-002	Classroom Bookcase	<input type="checkbox"/>	<input type="checkbox"/>
		1	S-003	Big Book Display	<input type="checkbox"/>	<input type="checkbox"/>
		3	S-004	Mobile Cubby Unit	<input type="checkbox"/>	<input type="checkbox"/>
		3	S-015	Classroom Bookcase	<input type="checkbox"/>	<input type="checkbox"/>
		5	T-001	Round Table	<input type="checkbox"/>	<input type="checkbox"/>
		2	T-002	Trapezoid Table	<input type="checkbox"/>	<input type="checkbox"/>
		1	T-003	Kidney Table	<input type="checkbox"/>	<input type="checkbox"/>
		1	T-004	Small Table	<input type="checkbox"/>	<input type="checkbox"/>
		2	T-006	Computer Tables	<input type="checkbox"/>	<input type="checkbox"/>
		1	T-007	ADA Compliant Tables	<input type="checkbox"/>	<input type="checkbox"/>
<b>A102</b>						
<b>Storage</b>						
		4	S-001	Metal Shelving	<input type="checkbox"/>	<input type="checkbox"/>
<b>A103</b>						
<b>Toilet</b>						
		1	A-001	Wastebasket	<input type="checkbox"/>	<input type="checkbox"/>
<b>A104</b>						

ROOM NUMBER	ROOM NAME	QTY	Type	Type Comments	ELIGIBILITY	
<b>Toliet</b>						
		1	A-001	Wastebasket	<input type="checkbox"/>	<input type="checkbox"/>
<b>A105</b>						
<b>Storage</b>						
		20	A-068	Child Cot	<input type="checkbox"/>	<input type="checkbox"/>
		2	S-001	Metal Shelving	<input type="checkbox"/>	<input type="checkbox"/>
<b>A106</b>						
<b>Pre K</b>						
		1	A-001	Wastebasket	<input type="checkbox"/>	<input type="checkbox"/>
		1	A-002	Classroom Flag	<input type="checkbox"/>	<input type="checkbox"/>
		1	A-008	Pencil Sharpener	<input type="checkbox"/>	<input type="checkbox"/>
		1	A-009	Pre K & K Rug	<input type="checkbox"/>	<input type="checkbox"/>
		1	A-018	Folder & Tray Cubby Mail Slots	<input type="checkbox"/>	<input type="checkbox"/>
		1	A-019	Wheasel	<input type="checkbox"/>	<input type="checkbox"/>
		1	A-020	1/2 Nursery Block Set	<input type="checkbox"/>	<input type="checkbox"/>
		1	A-021	Woodcrest Kitchen Set of 4	<input type="checkbox"/>	<input type="checkbox"/>
		1	A-022	Dress Up Unit	<input type="checkbox"/>	<input type="checkbox"/>
		1	A-061	Recycle Container	<input type="checkbox"/>	<input type="checkbox"/>
		24	A-063	Mini-White Boards	<input type="checkbox"/>	<input type="checkbox"/>
		1	A-064	Map Pack 1-Pre K-K	<input type="checkbox"/>	<input type="checkbox"/>
		12	A-145	Large Book Baskets	<input type="checkbox"/>	<input type="checkbox"/>
		12	A-146	Medium Book Basket	<input type="checkbox"/>	<input type="checkbox"/>
		35	CH-001	Pre K Chairs Xtra Small	<input type="checkbox"/>	<input type="checkbox"/>
		1	CH-006	Teacher Chair	<input type="checkbox"/>	<input type="checkbox"/>
		2	CH-007	Teacher Reading Chair	<input type="checkbox"/>	<input type="checkbox"/>
		1	D-003R	Teacher's Classroom Desk	<input type="checkbox"/>	<input type="checkbox"/>
		1	E-140	Laptop/ Document Camera Cart	<input type="checkbox"/>	<input type="checkbox"/>
		3	S-002	Classroom Bookcase	<input type="checkbox"/>	<input type="checkbox"/>
		1	S-003	Big Book Display	<input type="checkbox"/>	<input type="checkbox"/>
		3	S-004	Mobile Cubby Unit	<input type="checkbox"/>	<input type="checkbox"/>
		3	S-015	Classroom Bookcase	<input type="checkbox"/>	<input type="checkbox"/>
		5	T-001	Round Table	<input type="checkbox"/>	<input type="checkbox"/>
		2	T-002	Trapezoid Table	<input type="checkbox"/>	<input type="checkbox"/>
		1	T-003	Kidney Table	<input type="checkbox"/>	<input type="checkbox"/>
		1	T-004	Small Table	<input type="checkbox"/>	<input type="checkbox"/>
		2	T-006	Computer Tables	<input type="checkbox"/>	<input type="checkbox"/>
		1	T-007	ADA Compliant Tables	<input type="checkbox"/>	<input type="checkbox"/>

**A107**

ROOM NUMBER	ROOM NAME	QTY	Type	Type Comments	ELIGIBILITY	
<b>Pre K</b>						
		1	A-001	Wastebasket	<input type="checkbox"/>	<input type="checkbox"/>
		1	A-002	Classroom Flag	<input type="checkbox"/>	<input type="checkbox"/>
		1	A-008	Pencil Sharpener	<input type="checkbox"/>	<input type="checkbox"/>
		1	A-009	Pre K & K Rug	<input type="checkbox"/>	<input type="checkbox"/>
		1	A-018	Folder & Tray Cubby Mail Slots	<input type="checkbox"/>	<input type="checkbox"/>
		1	A-019	Wheasel	<input type="checkbox"/>	<input type="checkbox"/>
		1	A-020	1/2 Nursery Block Set	<input type="checkbox"/>	<input type="checkbox"/>
		1	A-021	Woodcrest Kitchen Set of 4	<input type="checkbox"/>	<input type="checkbox"/>
		1	A-022	Dress Up Unit	<input type="checkbox"/>	<input type="checkbox"/>
		1	A-061	Recycle Container	<input type="checkbox"/>	<input type="checkbox"/>
		24	A-063	Mini-White Boards	<input type="checkbox"/>	<input type="checkbox"/>
		1	A-064	Map Pack 1-Pre K-K	<input type="checkbox"/>	<input type="checkbox"/>
		12	A-145	Large Book Baskets	<input type="checkbox"/>	<input type="checkbox"/>
		12	A-146	Medium Book Basket	<input type="checkbox"/>	<input type="checkbox"/>
		35	CH-001	Pre K Chairs Xtra Small	<input type="checkbox"/>	<input type="checkbox"/>
		1	CH-006	Teacher Chair	<input type="checkbox"/>	<input type="checkbox"/>
		2	CH-007	Teacher Reading Chair	<input type="checkbox"/>	<input type="checkbox"/>
		1	D-003L	Teacher's Classroom Desk	<input type="checkbox"/>	<input type="checkbox"/>
		1	E-140	Laptop/ Document Camera Cart	<input type="checkbox"/>	<input type="checkbox"/>
		3	S-002	Classroom Bookcase	<input type="checkbox"/>	<input type="checkbox"/>
		1	S-003	Big Book Display	<input type="checkbox"/>	<input type="checkbox"/>
		3	S-004	Mobile Cubby Unit	<input type="checkbox"/>	<input type="checkbox"/>
		3	S-015	Classroom Bookcase	<input type="checkbox"/>	<input type="checkbox"/>
		5	T-001	Round Table	<input type="checkbox"/>	<input type="checkbox"/>
		2	T-002	Trapezoid Table	<input type="checkbox"/>	<input type="checkbox"/>
		1	T-003	Kidney Table	<input type="checkbox"/>	<input type="checkbox"/>
		1	T-004	Small Table	<input type="checkbox"/>	<input type="checkbox"/>
		2	T-006	Computer Tables	<input type="checkbox"/>	<input type="checkbox"/>
		1	T-007	ADA Compliant Tables	<input type="checkbox"/>	<input type="checkbox"/>
<b>A108</b>						
	<b>Toilet</b>					
		1	A-001	Wastebasket	<input type="checkbox"/>	<input type="checkbox"/>
<b>A109</b>						
	<b>Storage</b>					
		20	A-068	Child Cot	<input type="checkbox"/>	<input type="checkbox"/>
		2	S-001	Metal Shelving	<input type="checkbox"/>	<input type="checkbox"/>
<b>A110</b>						

ROOM NUMBER	ROOM NAME	QTY	Type	Type Comments	ELIGIBILITY	
<b>Storage</b>						
<b>A111</b>		4	S-001	Metal Shelving	<input type="checkbox"/>	<input type="checkbox"/>
	<b>Toliet</b>					
<b>A112</b>		1	A-001	Wastebasket	<input type="checkbox"/>	<input type="checkbox"/>
	<b>Kindergarten</b>					
		1	A-001	Wastebasket	<input type="checkbox"/>	<input type="checkbox"/>
		1	A-002	Classroom Flag	<input type="checkbox"/>	<input type="checkbox"/>
		1	A-008	Pencil Sharpener	<input type="checkbox"/>	<input type="checkbox"/>
		1	A-009	Pre K & K Rug	<input type="checkbox"/>	<input type="checkbox"/>
		1	A-018	Folder & Tray Cubby Mail Slots	<input type="checkbox"/>	<input type="checkbox"/>
		1	A-019	Wheasel	<input type="checkbox"/>	<input type="checkbox"/>
		1	A-020	1/2 Nursery Block Set	<input type="checkbox"/>	<input type="checkbox"/>
		1	A-061	Recycle Container	<input type="checkbox"/>	<input type="checkbox"/>
		24	A-063	Mini-White Boards	<input type="checkbox"/>	<input type="checkbox"/>
		1	A-064	Map Pack 1-Pre K-K	<input type="checkbox"/>	<input type="checkbox"/>
		12	A-145	Large Book Baskets	<input type="checkbox"/>	<input type="checkbox"/>
		12	A-146	Medium Book Basket	<input type="checkbox"/>	<input type="checkbox"/>
		35	CH-002	K + 1st Grade Small Chairs	<input type="checkbox"/>	<input type="checkbox"/>
		1	CH-006	Teacher Chair	<input type="checkbox"/>	<input type="checkbox"/>
		2	CH-007	Teacher Reading Chair	<input type="checkbox"/>	<input type="checkbox"/>
		1	D-003R	Teacher's Classroom Desk	<input type="checkbox"/>	<input type="checkbox"/>
		1	E-140	Laptop/ Document Camera Cart	<input type="checkbox"/>	<input type="checkbox"/>
		3	S-002	Classroom Bookcase	<input type="checkbox"/>	<input type="checkbox"/>
		1	S-003	Big Book Display	<input type="checkbox"/>	<input type="checkbox"/>
		3	S-004	Mobile Cubby Unit	<input type="checkbox"/>	<input type="checkbox"/>
		3	S-015	Classroom Bookcase	<input type="checkbox"/>	<input type="checkbox"/>
		5	T-001	Round Table	<input type="checkbox"/>	<input type="checkbox"/>
		2	T-002	Trapezoid Table	<input type="checkbox"/>	<input type="checkbox"/>
		1	T-003	Kidney Table	<input type="checkbox"/>	<input type="checkbox"/>
		1	T-004	Small Table	<input type="checkbox"/>	<input type="checkbox"/>
		2	T-006	Computer Tables	<input type="checkbox"/>	<input type="checkbox"/>
		1	T-007	ADA Compliant Tables	<input type="checkbox"/>	<input type="checkbox"/>
<b>A113</b>	<b>Kindergarten</b>					
		1	A-001	Wastebasket	<input type="checkbox"/>	<input type="checkbox"/>
		1	A-002	Classroom Flag	<input type="checkbox"/>	<input type="checkbox"/>



ROOM NUMBER	ROOM NAME	QTY	Type	Type Comments	ELIGIBILITY	
		1	A-008	Pencil Sharpener	<input type="checkbox"/>	<input type="checkbox"/>
		1	A-009	Pre K & K Rug	<input type="checkbox"/>	<input type="checkbox"/>
		1	A-018	Folder & Tray Cubby Mail Slots	<input type="checkbox"/>	<input type="checkbox"/>
		1	A-019	Wheasel	<input type="checkbox"/>	<input type="checkbox"/>
		1	A-020	1/2 Nursery Block Set	<input type="checkbox"/>	<input type="checkbox"/>
		1	A-061	Recycle Container	<input type="checkbox"/>	<input type="checkbox"/>
		24	A-063	Mini-White Boards	<input type="checkbox"/>	<input type="checkbox"/>
		1	A-064	Map Pack 1-Pre K-K	<input type="checkbox"/>	<input type="checkbox"/>
		12	A-145	Large Book Baskets	<input type="checkbox"/>	<input type="checkbox"/>
		12	A-146	Medium Book Basket	<input type="checkbox"/>	<input type="checkbox"/>
		35	CH-002	K + 1st Grade Small Chairs	<input type="checkbox"/>	<input type="checkbox"/>
		1	CH-006	Teacher Chair	<input type="checkbox"/>	<input type="checkbox"/>
		2	CH-007	Teacher Reading Chair	<input type="checkbox"/>	<input type="checkbox"/>
		1	D-003L	Teacher's Classroom Desk	<input type="checkbox"/>	<input type="checkbox"/>
		1	E-140	Laptop/ Document Camera Cart	<input type="checkbox"/>	<input type="checkbox"/>
		3	S-002	Classroom Bookcase	<input type="checkbox"/>	<input type="checkbox"/>
		1	S-003	Big Book Display	<input type="checkbox"/>	<input type="checkbox"/>
		3	S-004	Mobile Cubby Unit	<input type="checkbox"/>	<input type="checkbox"/>
		3	S-015	Classroom Bookcase	<input type="checkbox"/>	<input type="checkbox"/>
		5	T-001	Round Table	<input type="checkbox"/>	<input type="checkbox"/>
		2	T-002	Trapezoid Table	<input type="checkbox"/>	<input type="checkbox"/>
		1	T-003	Kidney Table	<input type="checkbox"/>	<input type="checkbox"/>
		1	T-004	Small Table	<input type="checkbox"/>	<input type="checkbox"/>
		2	T-006	Computer Tables	<input type="checkbox"/>	<input type="checkbox"/>
		1	T-007	ADA Compliant Tables	<input type="checkbox"/>	<input type="checkbox"/>
<b>A114</b>						
	<b>Storage</b>					
		4	S-001	Metal Shelving	<input type="checkbox"/>	<input type="checkbox"/>
<b>A115</b>						
	<b>Toilet</b>					
		1	A-001	Wastebasket	<input type="checkbox"/>	<input type="checkbox"/>
<b>A116</b>						
	<b>Storage</b>					
		20	A-068	Child Cot	<input type="checkbox"/>	<input type="checkbox"/>
		2	S-001	Metal Shelving	<input type="checkbox"/>	<input type="checkbox"/>
<b>A117</b>						
	<b>Toilet</b>					
		1	A-001	Wastebasket	<input type="checkbox"/>	<input type="checkbox"/>

ROOM NUMBER	ROOM NAME	QTY	Type	Type Comments	ELIGIBILITY	
<b>A118</b>						
<b>Pre K</b>						
		1	A-001	Wastebasket	<input type="checkbox"/>	<input type="checkbox"/>
		1	A-002	Classroom Flag	<input type="checkbox"/>	<input type="checkbox"/>
		1	A-008	Pencil Sharpener	<input type="checkbox"/>	<input type="checkbox"/>
		1	A-009	Pre K & K Rug	<input type="checkbox"/>	<input type="checkbox"/>
		1	A-018	Folder & Tray Cubby Mail Slots	<input type="checkbox"/>	<input type="checkbox"/>
		1	A-019	Wheasel	<input type="checkbox"/>	<input type="checkbox"/>
		1	A-020	1/2 Nursery Block Set	<input type="checkbox"/>	<input type="checkbox"/>
		1	A-021	Woodcrest Kitchen Set of 4	<input type="checkbox"/>	<input type="checkbox"/>
		1	A-022	Dress Up Unit	<input type="checkbox"/>	<input type="checkbox"/>
		1	A-061	Recycle Container	<input type="checkbox"/>	<input type="checkbox"/>
		24	A-063	Mini-White Boards	<input type="checkbox"/>	<input type="checkbox"/>
		1	A-064	Map Pack 1-Pre K-K	<input type="checkbox"/>	<input type="checkbox"/>
		12	A-145	Large Book Baskets	<input type="checkbox"/>	<input type="checkbox"/>
		12	A-146	Medium Book Basket	<input type="checkbox"/>	<input type="checkbox"/>
		35	CH-001	Pre K Chairs Xtra Small	<input type="checkbox"/>	<input type="checkbox"/>
		1	CH-006	Teacher Chair	<input type="checkbox"/>	<input type="checkbox"/>
		2	CH-007	Teacher Reading Chair	<input type="checkbox"/>	<input type="checkbox"/>
		1	D-003R	Teacher's Classroom Desk	<input type="checkbox"/>	<input type="checkbox"/>
		1	E-140	Laptop/ Document Camera Cart	<input type="checkbox"/>	<input type="checkbox"/>
		3	S-002	Classroom Bookcase	<input type="checkbox"/>	<input type="checkbox"/>
		1	S-003	Big Book Display	<input type="checkbox"/>	<input type="checkbox"/>
		3	S-004	Mobile Cubby Unit	<input type="checkbox"/>	<input type="checkbox"/>
		3	S-015	Classroom Bookcase	<input type="checkbox"/>	<input type="checkbox"/>
		5	T-001	Round Table	<input type="checkbox"/>	<input type="checkbox"/>
		2	T-002	Trapezoid Table	<input type="checkbox"/>	<input type="checkbox"/>
		1	T-003	Kidney Table	<input type="checkbox"/>	<input type="checkbox"/>
		1	T-004	Small Table	<input type="checkbox"/>	<input type="checkbox"/>
		2	T-006	Computer Tables	<input type="checkbox"/>	<input type="checkbox"/>
		1	T-007	ADA Compliant Tables	<input type="checkbox"/>	<input type="checkbox"/>
<b>A119</b>						
<b>1st Grade</b>						
		1	A-001	Wastebasket	<input type="checkbox"/>	<input type="checkbox"/>
		1	A-002	Classroom Flag	<input type="checkbox"/>	<input type="checkbox"/>
		1	A-008	Pencil Sharpener	<input type="checkbox"/>	<input type="checkbox"/>
		1	A-010	1st Grade Rug	<input type="checkbox"/>	<input type="checkbox"/>
		1	A-018	Folder & Tray Cubby Mail Slots	<input type="checkbox"/>	<input type="checkbox"/>

ROOM NUMBER	ROOM NAME	QTY	Type	Type Comments	ELIGIBILITY	
		1	A-019	Wheasel	<input type="checkbox"/>	<input type="checkbox"/>
		1	A-061	Recycle Container	<input type="checkbox"/>	<input type="checkbox"/>
		24	A-063	Mini-White Boards	<input type="checkbox"/>	<input type="checkbox"/>
		1	A-065	Map Pack 2- Grades 1+2	<input type="checkbox"/>	<input type="checkbox"/>
		12	A-145	Large Book Baskets	<input type="checkbox"/>	<input type="checkbox"/>
		12	A-146	Medium Book Basket	<input type="checkbox"/>	<input type="checkbox"/>
		35	CH-002	K + 1st Grade Small Chairs	<input type="checkbox"/>	<input type="checkbox"/>
		1	CH-006	Teacher Chair	<input type="checkbox"/>	<input type="checkbox"/>
		2	CH-007	Teacher Reading Chair	<input type="checkbox"/>	<input type="checkbox"/>
		1	D-003L	Teacher's Classroom Desk	<input type="checkbox"/>	<input type="checkbox"/>
		1	E-140	Laptop/ Document Camera Cart	<input type="checkbox"/>	<input type="checkbox"/>
		3	S-002	Classroom Bookcase	<input type="checkbox"/>	<input type="checkbox"/>
		1	S-003	Big Book Display	<input type="checkbox"/>	<input type="checkbox"/>
		3	S-004	Mobile Cubby Unit	<input type="checkbox"/>	<input type="checkbox"/>
		3	S-015	Classroom Bookcase	<input type="checkbox"/>	<input type="checkbox"/>
		5	T-001	Round Table	<input type="checkbox"/>	<input type="checkbox"/>
		2	T-002	Trapezoid Table	<input type="checkbox"/>	<input type="checkbox"/>
		1	T-003	Kidney Table	<input type="checkbox"/>	<input type="checkbox"/>
		1	T-004	Small Table	<input type="checkbox"/>	<input type="checkbox"/>
		2	T-006	Computer Tables	<input type="checkbox"/>	<input type="checkbox"/>
		1	T-007	ADA Compliant Tables	<input type="checkbox"/>	<input type="checkbox"/>
<b>A120</b>						
<b>Toilet</b>						
		1	A-001	Wastebasket	<input type="checkbox"/>	<input type="checkbox"/>
<b>A121</b>						
<b>Storage</b>						
		4	S-001	Metal Shelving	<input type="checkbox"/>	<input type="checkbox"/>
<b>A122</b>						
<b>Special Education</b>						
		1	A-001	Wastebasket	<input type="checkbox"/>	<input type="checkbox"/>
		1	A-002	Classroom Flag	<input type="checkbox"/>	<input type="checkbox"/>
		1	A-008	Pencil Sharpener	<input type="checkbox"/>	<input type="checkbox"/>
		1	A-018	Folder & Tray Cubby Mail Slots	<input type="checkbox"/>	<input type="checkbox"/>
		1	A-019	Wheasel	<input type="checkbox"/>	<input type="checkbox"/>
		2	A-023	Groupwork Screen	<input type="checkbox"/>	<input type="checkbox"/>
		1	A-061	Recycle Container	<input type="checkbox"/>	<input type="checkbox"/>
		12	A-063	Mini-White Boards	<input type="checkbox"/>	<input type="checkbox"/>
		1	A-065	Map Pack 2- Grades 1+2	<input type="checkbox"/>	<input type="checkbox"/>

ROOM NUMBER	ROOM NAME	QTY	Type	Type Comments	ELIGIBILITY	
		12	A-145	Large Book Baskets	<input type="checkbox"/>	<input type="checkbox"/>
		18	CH-002	K + 1st Grade Small Chairs	<input type="checkbox"/>	<input type="checkbox"/>
		1	CH-006	Teacher Chair	<input type="checkbox"/>	<input type="checkbox"/>
		2	CH-007	Teacher Reading Chair	<input type="checkbox"/>	<input type="checkbox"/>
		2	D-001	Student Desk w/ Book Basket Box	<input type="checkbox"/>	<input type="checkbox"/>
		1	D-002	ADA Compliant Student Desk	<input type="checkbox"/>	<input type="checkbox"/>
		1	D-003L	Teacher's Classroom Desk	<input type="checkbox"/>	<input type="checkbox"/>
		1	E-140	Laptop/ Document Camera Cart	<input type="checkbox"/>	<input type="checkbox"/>
		3	S-015	Classroom Bookcase	<input type="checkbox"/>	<input type="checkbox"/>
		4	T-002	Trapezoid Table	<input type="checkbox"/>	<input type="checkbox"/>
		1	T-004	Small Table	<input type="checkbox"/>	<input type="checkbox"/>
		1	T-006	Computer Tables	<input type="checkbox"/>	<input type="checkbox"/>
		1	T-007	ADA Compliant Tables	<input type="checkbox"/>	<input type="checkbox"/>

**A123**

**Special Ed Conference**

		1	A-001	Wastebasket	<input type="checkbox"/>	<input type="checkbox"/>
		1	A-061	Recycle Container	<input type="checkbox"/>	<input type="checkbox"/>
		5	CH-007	Teacher Reading Chair	<input type="checkbox"/>	<input type="checkbox"/>
		6	S-015	Classroom Bookcase	<input type="checkbox"/>	<input type="checkbox"/>
		1	T-009	Round Conference Table	<input type="checkbox"/>	<input type="checkbox"/>

**A124**

**Special Ed Office**

		1	A-001	Wastebasket	<input type="checkbox"/>	<input type="checkbox"/>
		1	A-061	Recycle Container	<input type="checkbox"/>	<input type="checkbox"/>
		1	CH-006	Teacher Chair	<input type="checkbox"/>	<input type="checkbox"/>
		2	CH-007	Teacher Reading Chair	<input type="checkbox"/>	<input type="checkbox"/>
		1	D-004	Small Private Office Desk	<input type="checkbox"/>	<input type="checkbox"/>

**A124A**

**Special Ed Office**

		1	A-001	Wastebasket	<input type="checkbox"/>	<input type="checkbox"/>
		1	A-061	Recycle Container	<input type="checkbox"/>	<input type="checkbox"/>
		1	CH-006	Teacher Chair	<input type="checkbox"/>	<input type="checkbox"/>
		2	CH-007	Teacher Reading Chair	<input type="checkbox"/>	<input type="checkbox"/>
		1	D-004	Small Private Office Desk	<input type="checkbox"/>	<input type="checkbox"/>

**A125**

**Instructional Production Area**

		1	A-001	Wastebasket	<input type="checkbox"/>	<input type="checkbox"/>
		1	A-002	Classroom Flag	<input type="checkbox"/>	<input type="checkbox"/>

ROOM NUMBER	ROOM NAME	QTY	Type	Type Comments	ELIGIBILITY	
		1	A-008	Pencil Sharpener	<input type="checkbox"/>	<input type="checkbox"/>
		1	A-061	Recycle Container	<input type="checkbox"/>	<input type="checkbox"/>
		25	CH-004	4 th + 5th Grade Large Chairs	<input type="checkbox"/>	<input type="checkbox"/>
		1	CH-006	Teacher Chair	<input type="checkbox"/>	<input type="checkbox"/>
		1	D-003R	Teacher's Classroom Desk	<input type="checkbox"/>	<input type="checkbox"/>
		1	E-140	Laptop/ Document Camera Cart	<input type="checkbox"/>	<input type="checkbox"/>
		25	T-008	Technology Tables	<input type="checkbox"/>	<input type="checkbox"/>
<b>A126</b>						
	<b>Office</b>					
		3	A-001	Wastebasket	<input type="checkbox"/>	<input type="checkbox"/>
		1	A-061	Recycle Container	<input type="checkbox"/>	<input type="checkbox"/>
		3	CH-006	Teacher Chair	<input type="checkbox"/>	<input type="checkbox"/>
		3	D-004	Small Private Office Desk	<input type="checkbox"/>	<input type="checkbox"/>
		3	S-009	Storage Cabinet	<input type="checkbox"/>	<input type="checkbox"/>
<b>A128</b>						
	<b>Storage</b>					
		4	S-001	Metal Shelving	<input type="checkbox"/>	<input type="checkbox"/>
<b>A129</b>						
	<b>Toilet</b>					
		1	A-001	Wastebasket	<input type="checkbox"/>	<input type="checkbox"/>
<b>A130</b>						
	<b>1st Grade</b>					
		1	A-001	Wastebasket	<input type="checkbox"/>	<input type="checkbox"/>
		1	A-002	Classroom Flag	<input type="checkbox"/>	<input type="checkbox"/>
		1	A-008	Pencil Sharpener	<input type="checkbox"/>	<input type="checkbox"/>
		1	A-010	1st Grade Rug	<input type="checkbox"/>	<input type="checkbox"/>
		1	A-018	Folder & Tray Cubby Mail Slots	<input type="checkbox"/>	<input type="checkbox"/>
		1	A-019	Wheasel	<input type="checkbox"/>	<input type="checkbox"/>
		1	A-061	Recycle Container	<input type="checkbox"/>	<input type="checkbox"/>
		24	A-063	Mini-White Boards	<input type="checkbox"/>	<input type="checkbox"/>
		1	A-065	Map Pack 2- Grades 1+2	<input type="checkbox"/>	<input type="checkbox"/>
		12	A-145	Large Book Baskets	<input type="checkbox"/>	<input type="checkbox"/>
		12	A-146	Medium Book Basket	<input type="checkbox"/>	<input type="checkbox"/>
		35	CH-002	K + 1st Grade Small Chairs	<input type="checkbox"/>	<input type="checkbox"/>
		1	CH-006	Teacher Chair	<input type="checkbox"/>	<input type="checkbox"/>
		2	CH-007	Teacher Reading Chair	<input type="checkbox"/>	<input type="checkbox"/>
		1	D-003R	Teacher's Classroom Desk	<input type="checkbox"/>	<input type="checkbox"/>
		1	E-140	Laptop/ Document Camera Cart	<input type="checkbox"/>	<input type="checkbox"/>

ROOM NUMBER	ROOM NAME	QTY	Type	Type Comments	ELIGIBILITY	
		3	S-002	Classroom Bookcase	<input type="checkbox"/>	<input type="checkbox"/>
		1	S-003	Big Book Display	<input type="checkbox"/>	<input type="checkbox"/>
		3	S-004	Mobile Cubby Unit	<input type="checkbox"/>	<input type="checkbox"/>
		3	S-015	Classroom Bookcase	<input type="checkbox"/>	<input type="checkbox"/>
		5	T-001	Round Table	<input type="checkbox"/>	<input type="checkbox"/>
		2	T-002	Trapezoid Table	<input type="checkbox"/>	<input type="checkbox"/>
		1	T-003	Kidney Table	<input type="checkbox"/>	<input type="checkbox"/>
		1	T-004	Small Table	<input type="checkbox"/>	<input type="checkbox"/>
		2	T-006	Computer Tables	<input type="checkbox"/>	<input type="checkbox"/>
		1	T-007	ADA Compliant Tables	<input type="checkbox"/>	<input type="checkbox"/>

**A201**

**4th Grade**

		1	A-001	Wastebasket	<input type="checkbox"/>	<input type="checkbox"/>
		1	A-002	Classroom Flag	<input type="checkbox"/>	<input type="checkbox"/>
		1	A-008	Pencil Sharpener	<input type="checkbox"/>	<input type="checkbox"/>
		1	A-013	4th Grade Rug	<input type="checkbox"/>	<input type="checkbox"/>
		1	A-018	Folder & Tray Cubby Mail Slots	<input type="checkbox"/>	<input type="checkbox"/>
		1	A-019	Wheasel	<input type="checkbox"/>	<input type="checkbox"/>
		1	A-061	Recycle Container	<input type="checkbox"/>	<input type="checkbox"/>
		24	A-063	Mini-White Boards	<input type="checkbox"/>	<input type="checkbox"/>
		1	A-066	Map Pack 3-Grades 3+4	<input type="checkbox"/>	<input type="checkbox"/>
		12	A-145	Large Book Baskets	<input type="checkbox"/>	<input type="checkbox"/>
		12	A-146	Medium Book Basket	<input type="checkbox"/>	<input type="checkbox"/>
		35	CH-004	4 th + 5th Grade Large Chairs	<input type="checkbox"/>	<input type="checkbox"/>
		1	CH-006	Teacher Chair	<input type="checkbox"/>	<input type="checkbox"/>
		2	CH-007	Teacher Reading Chair	<input type="checkbox"/>	<input type="checkbox"/>
		23	D-001	Student Desk w/ Book Basket Box	<input type="checkbox"/>	<input type="checkbox"/>
		1	D-002	ADA Compliant Student Desk	<input type="checkbox"/>	<input type="checkbox"/>
		1	D-003L	Teacher's Classroom Desk	<input type="checkbox"/>	<input type="checkbox"/>
		1	E-140	Laptop/ Document Camera Cart	<input type="checkbox"/>	<input type="checkbox"/>
		3	S-004	Mobile Cubby Unit	<input type="checkbox"/>	<input type="checkbox"/>
		3	S-015	Classroom Bookcase	<input type="checkbox"/>	<input type="checkbox"/>
		4	S-018	Classroom Bookcase	<input type="checkbox"/>	<input type="checkbox"/>
		1	T-004	Small Table	<input type="checkbox"/>	<input type="checkbox"/>
		2	T-006	Computer Tables	<input type="checkbox"/>	<input type="checkbox"/>
		1	T-007	ADA Compliant Tables	<input type="checkbox"/>	<input type="checkbox"/>
		2	T-010	Round Student Tables	<input type="checkbox"/>	<input type="checkbox"/>

**A202**

ROOM NUMBER	ROOM NAME	QTY	Type	Type Comments	ELIGIBILITY	
<b>5th Grade</b>						
		1	A-001	Wastebasket	<input type="checkbox"/>	<input type="checkbox"/>
		1	A-002	Classroom Flag	<input type="checkbox"/>	<input type="checkbox"/>
		1	A-008	Pencil Sharpener	<input type="checkbox"/>	<input type="checkbox"/>
		1	A-014	5th Grade Rug	<input type="checkbox"/>	<input type="checkbox"/>
		1	A-018	Folder & Tray Cubby Mail Slots	<input type="checkbox"/>	<input type="checkbox"/>
		1	A-019	Wheasel	<input type="checkbox"/>	<input type="checkbox"/>
		1	A-061	Recycle Container	<input type="checkbox"/>	<input type="checkbox"/>
		24	A-063	Mini-White Boards	<input type="checkbox"/>	<input type="checkbox"/>
		1	A-067	Map Pack 4- Grade 5	<input type="checkbox"/>	<input type="checkbox"/>
		12	A-145	Large Book Baskets	<input type="checkbox"/>	<input type="checkbox"/>
		12	A-146	Medium Book Basket	<input type="checkbox"/>	<input type="checkbox"/>
		35	CH-004	4 th + 5th Grade Large Chairs	<input type="checkbox"/>	<input type="checkbox"/>
		1	CH-006	Teacher Chair	<input type="checkbox"/>	<input type="checkbox"/>
		2	CH-007	Teacher Reading Chair	<input type="checkbox"/>	<input type="checkbox"/>
		23	D-001	Student Desk w/ Book Basket Box	<input type="checkbox"/>	<input type="checkbox"/>
		1	D-002	ADA Compliant Student Desk	<input type="checkbox"/>	<input type="checkbox"/>
		1	D-003R	Teacher's Classroom Desk	<input type="checkbox"/>	<input type="checkbox"/>
		1	E-140	Laptop/ Document Camera Cart	<input type="checkbox"/>	<input type="checkbox"/>
		3	S-004	Mobile Cubby Unit	<input type="checkbox"/>	<input type="checkbox"/>
		3	S-015	Classroom Bookcase	<input type="checkbox"/>	<input type="checkbox"/>
		5	S-018	Classroom Bookcase	<input type="checkbox"/>	<input type="checkbox"/>
		1	T-004	Small Table	<input type="checkbox"/>	<input type="checkbox"/>
		2	T-006	Computer Tables	<input type="checkbox"/>	<input type="checkbox"/>
		1	T-007	ADA Compliant Tables	<input type="checkbox"/>	<input type="checkbox"/>
		2	T-010	Round Student Tables	<input type="checkbox"/>	<input type="checkbox"/>

**A203**

**4th Grade**

		1	A-001	Wastebasket	<input type="checkbox"/>	<input type="checkbox"/>
		1	A-002	Classroom Flag	<input type="checkbox"/>	<input type="checkbox"/>
		1	A-008	Pencil Sharpener	<input type="checkbox"/>	<input type="checkbox"/>
		1	A-013	4th Grade Rug	<input type="checkbox"/>	<input type="checkbox"/>
		1	A-018	Folder & Tray Cubby Mail Slots	<input type="checkbox"/>	<input type="checkbox"/>
		1	A-019	Wheasel	<input type="checkbox"/>	<input type="checkbox"/>
		1	A-061	Recycle Container	<input type="checkbox"/>	<input type="checkbox"/>
		24	A-063	Mini-White Boards	<input type="checkbox"/>	<input type="checkbox"/>
		1	A-066	Map Pack 3-Grades 3+4	<input type="checkbox"/>	<input type="checkbox"/>
		12	A-145	Large Book Baskets	<input type="checkbox"/>	<input type="checkbox"/>

ROOM NUMBER	ROOM NAME	QTY	Type	Type Comments	ELIGIBILITY	
		12	A-146	Medium Book Basket	<input type="checkbox"/>	<input type="checkbox"/>
		35	CH-004	4 th + 5th Grade Large Chairs	<input type="checkbox"/>	<input type="checkbox"/>
		1	CH-006	Teacher Chair	<input type="checkbox"/>	<input type="checkbox"/>
		2	CH-007	Teacher Reading Chair	<input type="checkbox"/>	<input type="checkbox"/>
		23	D-001	Student Desk w/ Book Basket Box	<input type="checkbox"/>	<input type="checkbox"/>
		1	D-002	ADA Compliant Student Desk	<input type="checkbox"/>	<input type="checkbox"/>
		1	D-003R	Teacher's Classroom Desk	<input type="checkbox"/>	<input type="checkbox"/>
		1	E-140	Laptop/ Document Camera Cart	<input type="checkbox"/>	<input type="checkbox"/>
		3	S-004	Mobile Cubby Unit	<input type="checkbox"/>	<input type="checkbox"/>
		3	S-015	Classroom Bookcase	<input type="checkbox"/>	<input type="checkbox"/>
		4	S-018	Classroom Bookcase	<input type="checkbox"/>	<input type="checkbox"/>
		1	T-004	Small Table	<input type="checkbox"/>	<input type="checkbox"/>
		2	T-006	Computer Tables	<input type="checkbox"/>	<input type="checkbox"/>
		1	T-007	ADA Compliant Tables	<input type="checkbox"/>	<input type="checkbox"/>
		2	T-010	Round Student Tables	<input type="checkbox"/>	<input type="checkbox"/>

**A204**

**5th Grade**

		1	A-001	Wastebasket	<input type="checkbox"/>	<input type="checkbox"/>
		1	A-002	Classroom Flag	<input type="checkbox"/>	<input type="checkbox"/>
		1	A-008	Pencil Sharpener	<input type="checkbox"/>	<input type="checkbox"/>
		1	A-014	5th Grade Rug	<input type="checkbox"/>	<input type="checkbox"/>
		1	A-018	Folder & Tray Cubby Mail Slots	<input type="checkbox"/>	<input type="checkbox"/>
		1	A-019	Wheasel	<input type="checkbox"/>	<input type="checkbox"/>
		1	A-061	Recycle Container	<input type="checkbox"/>	<input type="checkbox"/>
		24	A-063	Mini-White Boards	<input type="checkbox"/>	<input type="checkbox"/>
		1	A-067	Map Pack 4- Grade 5	<input type="checkbox"/>	<input type="checkbox"/>
		12	A-145	Large Book Baskets	<input type="checkbox"/>	<input type="checkbox"/>
		12	A-146	Medium Book Basket	<input type="checkbox"/>	<input type="checkbox"/>
		35	CH-004	4 th + 5th Grade Large Chairs	<input type="checkbox"/>	<input type="checkbox"/>
		1	CH-006	Teacher Chair	<input type="checkbox"/>	<input type="checkbox"/>
		2	CH-007	Teacher Reading Chair	<input type="checkbox"/>	<input type="checkbox"/>
		23	D-001	Student Desk w/ Book Basket Box	<input type="checkbox"/>	<input type="checkbox"/>
		1	D-002	ADA Compliant Student Desk	<input type="checkbox"/>	<input type="checkbox"/>
		1	D-003L	Teacher's Classroom Desk	<input type="checkbox"/>	<input type="checkbox"/>
		1	E-140	Laptop/ Document Camera Cart	<input type="checkbox"/>	<input type="checkbox"/>
		3	S-004	Mobile Cubby Unit	<input type="checkbox"/>	<input type="checkbox"/>
		3	S-015	Classroom Bookcase	<input type="checkbox"/>	<input type="checkbox"/>
		5	S-018	Classroom Bookcase	<input type="checkbox"/>	<input type="checkbox"/>



ROOM NUMBER	ROOM NAME	QTY	Type	Type Comments	ELIGIBILITY	
		1	T-004	Small Table	<input type="checkbox"/>	<input type="checkbox"/>
		2	T-006	Computer Tables	<input type="checkbox"/>	<input type="checkbox"/>
		1	T-007	ADA Compliant Tables	<input type="checkbox"/>	<input type="checkbox"/>
		2	T-010	Round Student Tables	<input type="checkbox"/>	<input type="checkbox"/>

**A205**

**4th Grade**

		1	A-001	Wastebasket	<input type="checkbox"/>	<input type="checkbox"/>
		1	A-002	Classroom Flag	<input type="checkbox"/>	<input type="checkbox"/>
		1	A-008	Pencil Sharpener	<input type="checkbox"/>	<input type="checkbox"/>
		1	A-013	4th Grade Rug	<input type="checkbox"/>	<input type="checkbox"/>
		1	A-018	Folder & Tray Cubby Mail Slots	<input type="checkbox"/>	<input type="checkbox"/>
		1	A-019	Wheasel	<input type="checkbox"/>	<input type="checkbox"/>
		1	A-061	Recycle Container	<input type="checkbox"/>	<input type="checkbox"/>
		24	A-063	Mini-White Boards	<input type="checkbox"/>	<input type="checkbox"/>
		1	A-066	Map Pack 3-Grades 3+4	<input type="checkbox"/>	<input type="checkbox"/>
		12	A-145	Large Book Baskets	<input type="checkbox"/>	<input type="checkbox"/>
		12	A-146	Medium Book Basket	<input type="checkbox"/>	<input type="checkbox"/>
		35	CH-004	4 th + 5th Grade Large Chairs	<input type="checkbox"/>	<input type="checkbox"/>
		1	CH-006	Teacher Chair	<input type="checkbox"/>	<input type="checkbox"/>
		2	CH-007	Teacher Reading Chair	<input type="checkbox"/>	<input type="checkbox"/>
		23	D-001	Student Desk w/ Book Basket Box	<input type="checkbox"/>	<input type="checkbox"/>
		1	D-002	ADA Compliant Student Desk	<input type="checkbox"/>	<input type="checkbox"/>
		1	D-003L	Teacher's Classroom Desk	<input type="checkbox"/>	<input type="checkbox"/>
		1	E-140	Laptop/ Document Camera Cart	<input type="checkbox"/>	<input type="checkbox"/>
		3	S-004	Mobile Cubby Unit	<input type="checkbox"/>	<input type="checkbox"/>
		3	S-015	Classroom Bookcase	<input type="checkbox"/>	<input type="checkbox"/>
		4	S-018	Classroom Bookcase	<input type="checkbox"/>	<input type="checkbox"/>
		1	T-004	Small Table	<input type="checkbox"/>	<input type="checkbox"/>
		2	T-006	Computer Tables	<input type="checkbox"/>	<input type="checkbox"/>
		1	T-007	ADA Compliant Tables	<input type="checkbox"/>	<input type="checkbox"/>
		2	T-010	Round Student Tables	<input type="checkbox"/>	<input type="checkbox"/>

**A206**

**5th Grade**

		1	A-001	Wastebasket	<input type="checkbox"/>	<input type="checkbox"/>
		1	A-002	Classroom Flag	<input type="checkbox"/>	<input type="checkbox"/>
		1	A-008	Pencil Sharpener	<input type="checkbox"/>	<input type="checkbox"/>
		1	A-014	5th Grade Rug	<input type="checkbox"/>	<input type="checkbox"/>
		1	A-018	Folder & Tray Cubby Mail Slots	<input type="checkbox"/>	<input type="checkbox"/>

ROOM NUMBER	ROOM NAME	QTY	Type	Type Comments	ELIGIBILITY	
		1	A-019	Wheasel	<input type="checkbox"/>	<input type="checkbox"/>
		1	A-061	Recycle Container	<input type="checkbox"/>	<input type="checkbox"/>
		24	A-063	Mini-White Boards	<input type="checkbox"/>	<input type="checkbox"/>
		1	A-067	Map Pack 4- Grade 5	<input type="checkbox"/>	<input type="checkbox"/>
		12	A-145	Large Book Baskets	<input type="checkbox"/>	<input type="checkbox"/>
		12	A-146	Medium Book Basket	<input type="checkbox"/>	<input type="checkbox"/>
		35	CH-004	4 th + 5th Grade Large Chairs	<input type="checkbox"/>	<input type="checkbox"/>
		1	CH-006	Teacher Chair	<input type="checkbox"/>	<input type="checkbox"/>
		2	CH-007	Teacher Reading Chair	<input type="checkbox"/>	<input type="checkbox"/>
		23	D-001	Student Desk w/ Book Basket Box	<input type="checkbox"/>	<input type="checkbox"/>
		1	D-002	ADA Compliant Student Desk	<input type="checkbox"/>	<input type="checkbox"/>
		1	D-003R	Teacher's Classroom Desk	<input type="checkbox"/>	<input type="checkbox"/>
		1	E-140	Laptop/ Document Camera Cart	<input type="checkbox"/>	<input type="checkbox"/>
		3	S-004	Mobile Cubby Unit	<input type="checkbox"/>	<input type="checkbox"/>
		3	S-015	Classroom Bookcase	<input type="checkbox"/>	<input type="checkbox"/>
		5	S-018	Classroom Bookcase	<input type="checkbox"/>	<input type="checkbox"/>
		1	T-004	Small Table	<input type="checkbox"/>	<input type="checkbox"/>
		2	T-006	Computer Tables	<input type="checkbox"/>	<input type="checkbox"/>
		1	T-007	ADA Compliant Tables	<input type="checkbox"/>	<input type="checkbox"/>
		2	T-010	Round Student Tables	<input type="checkbox"/>	<input type="checkbox"/>

**A207**

**Special Education**

		1	A-001	Wastebasket	<input type="checkbox"/>	<input type="checkbox"/>
		1	A-002	Classroom Flag	<input type="checkbox"/>	<input type="checkbox"/>
		1	A-008	Pencil Sharpener	<input type="checkbox"/>	<input type="checkbox"/>
		1	A-019	Wheasel	<input type="checkbox"/>	<input type="checkbox"/>
		2	A-023	Groupwork Screen	<input type="checkbox"/>	<input type="checkbox"/>
		1	A-061	Recycle Container	<input type="checkbox"/>	<input type="checkbox"/>
		12	A-145	Large Book Baskets	<input type="checkbox"/>	<input type="checkbox"/>
		12	A-146	Medium Book Basket	<input type="checkbox"/>	<input type="checkbox"/>
		14	CH-004	4 th + 5th Grade Large Chairs	<input type="checkbox"/>	<input type="checkbox"/>
		1	CH-006	Teacher Chair	<input type="checkbox"/>	<input type="checkbox"/>
		2	CH-007	Teacher Reading Chair	<input type="checkbox"/>	<input type="checkbox"/>
		1	D-003L	Teacher's Classroom Desk	<input type="checkbox"/>	<input type="checkbox"/>
		1	E-140	Laptop/ Document Camera Cart	<input type="checkbox"/>	<input type="checkbox"/>
		2	T-002	Trapezoid Table	<input type="checkbox"/>	<input type="checkbox"/>
		1	T-003	Kidney Table	<input type="checkbox"/>	<input type="checkbox"/>
		1	T-006	Computer Tables	<input type="checkbox"/>	<input type="checkbox"/>

ROOM NUMBER	ROOM NAME	QTY	Type	Type Comments	ELIGIBILITY	
		1	T-007	ADA Compliant Tables	<input type="checkbox"/>	<input type="checkbox"/>
<b>A208</b>						
	<b>Special Education</b>					
		1	A-001	Wastebasket	<input type="checkbox"/>	<input type="checkbox"/>
		1	A-002	Classroom Flag	<input type="checkbox"/>	<input type="checkbox"/>
		1	A-008	Pencil Sharpener	<input type="checkbox"/>	<input type="checkbox"/>
		1	A-019	Wheasel	<input type="checkbox"/>	<input type="checkbox"/>
		2	A-023	Groupwork Screen	<input type="checkbox"/>	<input type="checkbox"/>
		1	A-061	Recycle Container	<input type="checkbox"/>	<input type="checkbox"/>
		12	A-145	Large Book Baskets	<input type="checkbox"/>	<input type="checkbox"/>
		12	A-146	Medium Book Basket	<input type="checkbox"/>	<input type="checkbox"/>
		14	CH-003	2nd + 3rd Grade Medium Chairs	<input type="checkbox"/>	<input type="checkbox"/>
		1	CH-006	Teacher Chair	<input type="checkbox"/>	<input type="checkbox"/>
		2	CH-007	Teacher Reading Chair	<input type="checkbox"/>	<input type="checkbox"/>
		1	D-003R	Teacher's Classroom Desk	<input type="checkbox"/>	<input type="checkbox"/>
		1	E-140	Laptop/ Document Camera Cart	<input type="checkbox"/>	<input type="checkbox"/>
		2	T-002	Trapezoid Table	<input type="checkbox"/>	<input type="checkbox"/>
		1	T-003	Kidney Table	<input type="checkbox"/>	<input type="checkbox"/>
		1	T-006	Computer Tables	<input type="checkbox"/>	<input type="checkbox"/>
		1	T-007	ADA Compliant Tables	<input type="checkbox"/>	<input type="checkbox"/>
<b>A214</b>						
	<b>2nd Grade</b>					
		1	A-001	Wastebasket	<input type="checkbox"/>	<input type="checkbox"/>
		1	A-002	Classroom Flag	<input type="checkbox"/>	<input type="checkbox"/>
		1	A-008	Pencil Sharpener	<input type="checkbox"/>	<input type="checkbox"/>
		1	A-011	2nd Grade Rug	<input type="checkbox"/>	<input type="checkbox"/>
		1	A-018	Folder & Tray Cubby Mail Slots	<input type="checkbox"/>	<input type="checkbox"/>
		1	A-019	Wheasel	<input type="checkbox"/>	<input type="checkbox"/>
		1	A-061	Recycle Container	<input type="checkbox"/>	<input type="checkbox"/>
		24	A-063	Mini-White Boards	<input type="checkbox"/>	<input type="checkbox"/>
		1	A-065	Map Pack 2- Grades 1+2	<input type="checkbox"/>	<input type="checkbox"/>
		12	A-145	Large Book Baskets	<input type="checkbox"/>	<input type="checkbox"/>
		12	A-146	Medium Book Basket	<input type="checkbox"/>	<input type="checkbox"/>
		35	CH-003	2nd + 3rd Grade Medium Chairs	<input type="checkbox"/>	<input type="checkbox"/>
		1	CH-006	Teacher Chair	<input type="checkbox"/>	<input type="checkbox"/>
		2	CH-007	Teacher Reading Chair	<input type="checkbox"/>	<input type="checkbox"/>
		23	D-001	Student Desk w/ Book Basket Box	<input type="checkbox"/>	<input type="checkbox"/>
		1	D-002	ADA Compliant Student Desk	<input type="checkbox"/>	<input type="checkbox"/>

ROOM NUMBER	ROOM NAME	QTY	Type	Type Comments	ELIGIBILITY	
		1	D-003L	Teacher's Classroom Desk	<input type="checkbox"/>	<input type="checkbox"/>
		1	E-140	Laptop/ Document Camera Cart	<input type="checkbox"/>	<input type="checkbox"/>
		3	S-004	Mobile Cubby Unit	<input type="checkbox"/>	<input type="checkbox"/>
		3	S-015	Classroom Bookcase	<input type="checkbox"/>	<input type="checkbox"/>
		2	S-018	Classroom Bookcase	<input type="checkbox"/>	<input type="checkbox"/>
		1	T-003	Kidney Table	<input type="checkbox"/>	<input type="checkbox"/>
		1	T-004	Small Table	<input type="checkbox"/>	<input type="checkbox"/>
		2	T-006	Computer Tables	<input type="checkbox"/>	<input type="checkbox"/>
		1	T-007	ADA Compliant Tables	<input type="checkbox"/>	<input type="checkbox"/>
		1	T-010	Round Student Tables	<input type="checkbox"/>	<input type="checkbox"/>

**A215**

**3rd Grade**

		1	A-001	Wastebasket	<input type="checkbox"/>	<input type="checkbox"/>
		1	A-002	Classroom Flag	<input type="checkbox"/>	<input type="checkbox"/>
		1	A-008	Pencil Sharpener	<input type="checkbox"/>	<input type="checkbox"/>
		1	A-012	3rd Grade Rug	<input type="checkbox"/>	<input type="checkbox"/>
		1	A-018	Folder & Tray Cubby Mail Slots	<input type="checkbox"/>	<input type="checkbox"/>
		1	A-019	Wheasel	<input type="checkbox"/>	<input type="checkbox"/>
		1	A-061	Recycle Container	<input type="checkbox"/>	<input type="checkbox"/>
		24	A-063	Mini-White Boards	<input type="checkbox"/>	<input type="checkbox"/>
		1	A-066	Map Pack 3-Grades 3+4	<input type="checkbox"/>	<input type="checkbox"/>
		12	A-145	Large Book Baskets	<input type="checkbox"/>	<input type="checkbox"/>
		12	A-146	Medium Book Basket	<input type="checkbox"/>	<input type="checkbox"/>
		35	CH-003	2nd + 3rd Grade Medium Chairs	<input type="checkbox"/>	<input type="checkbox"/>
		1	CH-006	Teacher Chair	<input type="checkbox"/>	<input type="checkbox"/>
		2	CH-007	Teacher Reading Chair	<input type="checkbox"/>	<input type="checkbox"/>
		23	D-001	Student Desk w/ Book Basket Box	<input type="checkbox"/>	<input type="checkbox"/>
		1	D-002	ADA Compliant Student Desk	<input type="checkbox"/>	<input type="checkbox"/>
		1	D-003R	Teacher's Classroom Desk	<input type="checkbox"/>	<input type="checkbox"/>
		1	E-140	Laptop/ Document Camera Cart	<input type="checkbox"/>	<input type="checkbox"/>
		3	S-004	Mobile Cubby Unit	<input type="checkbox"/>	<input type="checkbox"/>
		3	S-015	Classroom Bookcase	<input type="checkbox"/>	<input type="checkbox"/>
		3	S-018	Classroom Bookcase	<input type="checkbox"/>	<input type="checkbox"/>
		1	T-003	Kidney Table	<input type="checkbox"/>	<input type="checkbox"/>
		1	T-004	Small Table	<input type="checkbox"/>	<input type="checkbox"/>
		2	T-006	Computer Tables	<input type="checkbox"/>	<input type="checkbox"/>
		1	T-007	ADA Compliant Tables	<input type="checkbox"/>	<input type="checkbox"/>
		1	T-010	Round Student Tables	<input type="checkbox"/>	<input type="checkbox"/>

ROOM NUMBER	ROOM NAME	QTY	Type	Type Comments	ELIGIBILITY	
<b>B003</b>						
<b>Storage B</b>						
		26	S-001	Metal Shelving	<input type="checkbox"/>	<input type="checkbox"/>
<b>B101</b>						
<b>Media Center</b>						
		2	A-001	Wastebasket	<input type="checkbox"/>	<input type="checkbox"/>
		1	A-047	Globe	<input type="checkbox"/>	<input type="checkbox"/>
		1	CH-006	Teacher Chair	<input type="checkbox"/>	<input type="checkbox"/>
		1	CH-007	Teacher Reading Chair	<input type="checkbox"/>	<input type="checkbox"/>
		35	CH-018	Library Chairs	<input type="checkbox"/>	<input type="checkbox"/>
		8	CH-019	Library Soft Seating 1	<input type="checkbox"/>	<input type="checkbox"/>
		8	CH-020	Library Soft Seating 2	<input type="checkbox"/>	<input type="checkbox"/>
		6	T-017	Library Tables	<input type="checkbox"/>	<input type="checkbox"/>
<b>B106</b>						
<b>Gallery</b>						
		1	CH-007	Teacher Reading Chair	<input type="checkbox"/>	<input type="checkbox"/>
		1	D-008	Proof Mobile Desk	<input type="checkbox"/>	<input type="checkbox"/>
<b>B107</b>						
<b>Curriculum Coor Office</b>						
		1	A-001	Wastebasket	<input type="checkbox"/>	<input type="checkbox"/>
		1	A-061	Recycle Container	<input type="checkbox"/>	<input type="checkbox"/>
		1	CH-006	Teacher Chair	<input type="checkbox"/>	<input type="checkbox"/>
		2	CH-007	Teacher Reading Chair	<input type="checkbox"/>	<input type="checkbox"/>
		1	D-005	Large Private Office Desk	<input type="checkbox"/>	<input type="checkbox"/>
		2	S-015	Classroom Bookcase	<input type="checkbox"/>	<input type="checkbox"/>
<b>B107A</b>						
<b>Psychologist Office</b>						
		1	A-001	Wastebasket	<input type="checkbox"/>	<input type="checkbox"/>
		1	A-061	Recycle Container	<input type="checkbox"/>	<input type="checkbox"/>
		4	CH-002	K + 1st Grade Small Chairs	<input type="checkbox"/>	<input type="checkbox"/>
		1	CH-006	Teacher Chair	<input type="checkbox"/>	<input type="checkbox"/>
		1	D-004	Small Private Office Desk	<input type="checkbox"/>	<input type="checkbox"/>
		2	S-015	Classroom Bookcase	<input type="checkbox"/>	<input type="checkbox"/>
		1	T-001	Round Table	<input type="checkbox"/>	<input type="checkbox"/>
<b>B108</b>						
<b>Copy Room</b>						
		1	A-005	Large Garbage	<input type="checkbox"/>	<input type="checkbox"/>
		1	A-061	Recycle Container	<input type="checkbox"/>	<input type="checkbox"/>

ROOM NUMBER	ROOM NAME	QTY	Type	Type Comments	ELIGIBILITY	
<b>B111</b>						
<b>General Storage</b>						
		6	S-015	Classroom Bookcase	<input type="checkbox"/>	<input type="checkbox"/>
<b>B113</b>						
<b>Library Workroom</b>						
		1	A-001	Wastebasket	<input type="checkbox"/>	<input type="checkbox"/>
		1	A-008	Pencil Sharpener	<input type="checkbox"/>	<input type="checkbox"/>
		1	A-048	Constellation Globe	<input type="checkbox"/>	<input type="checkbox"/>
		1	A-050	Binding Machine	<input type="checkbox"/>	<input type="checkbox"/>
		1	A-051	Long Range Stapler	<input type="checkbox"/>	<input type="checkbox"/>
		1	A-052	Heavy Duty Stapler	<input type="checkbox"/>	<input type="checkbox"/>
		1	A-053	Die Cutter	<input type="checkbox"/>	<input type="checkbox"/>
		1	A-061	Recycle Container	<input type="checkbox"/>	<input type="checkbox"/>
		1	CH-006	Teacher Chair	<input type="checkbox"/>	<input type="checkbox"/>
		1	D-004	Small Private Office Desk	<input type="checkbox"/>	<input type="checkbox"/>
<b>B113A</b>						
<b>Book Storage</b>						
		4	S-001	Metal Shelving	<input type="checkbox"/>	<input type="checkbox"/>
<b>B114</b>						
<b>Parent Resource Room</b>						
		1	A-001	Wastebasket	<input type="checkbox"/>	<input type="checkbox"/>
		1	A-061	Recycle Container	<input type="checkbox"/>	<input type="checkbox"/>
		7	CH-010	Conference Chairs	<input type="checkbox"/>	<input type="checkbox"/>
		4	S-009	Storage Cabinet	<input type="checkbox"/>	<input type="checkbox"/>
		1	T-007	ADA Compliant Tables	<input type="checkbox"/>	<input type="checkbox"/>
		1	T-016	Boat Shaped Conference Table	<input type="checkbox"/>	<input type="checkbox"/>
<b>B117</b>						
<b>Storage Room</b>						
		12	S-001	Metal Shelving	<input type="checkbox"/>	<input type="checkbox"/>
<b>B118</b>						
<b>Science Classroom</b>						
		1	A-001	Wastebasket	<input type="checkbox"/>	<input type="checkbox"/>
		1	A-002	Classroom Flag	<input type="checkbox"/>	<input type="checkbox"/>
		1	A-008	Pencil Sharpener	<input type="checkbox"/>	<input type="checkbox"/>
		1	A-061	Recycle Container	<input type="checkbox"/>	<input type="checkbox"/>
		24	A-063	Mini-White Boards	<input type="checkbox"/>	<input type="checkbox"/>
		1	CH-006	Teacher Chair	<input type="checkbox"/>	<input type="checkbox"/>
		30	CH-014	Classroom Stools	<input type="checkbox"/>	<input type="checkbox"/>

ROOM NUMBER	ROOM NAME	QTY	Type	Type Comments	ELIGIBILITY	
		30	CH-021	Stool	<input type="checkbox"/>	<input type="checkbox"/>
		1	D-003R	Teacher's Classroom Desk	<input type="checkbox"/>	<input type="checkbox"/>
		1	E-096	Stereo Microscopes	<input type="checkbox"/>	<input type="checkbox"/>
		1	E-097	Human Life Skeleton	<input type="checkbox"/>	<input type="checkbox"/>
		1	E-098	Human Eye Model	<input type="checkbox"/>	<input type="checkbox"/>
		1	E-099	Human Ear Model	<input type="checkbox"/>	<input type="checkbox"/>
		1	E-100	Human Heart Model	<input type="checkbox"/>	<input type="checkbox"/>
		1	E-101	Animal Skeleton Snake	<input type="checkbox"/>	<input type="checkbox"/>
		1	E-102	Long Handed Nets 1	<input type="checkbox"/>	<input type="checkbox"/>
		1	E-103	Short Handed Strainers	<input type="checkbox"/>	<input type="checkbox"/>
		1	E-104	Long Handed Nets 2	<input type="checkbox"/>	<input type="checkbox"/>
		1	E-105	Trowels	<input type="checkbox"/>	<input type="checkbox"/>
		1	E-106	Pig Lung Demo Kit	<input type="checkbox"/>	<input type="checkbox"/>
		1	E-107	Digital Thermometers	<input type="checkbox"/>	<input type="checkbox"/>
		1	E-108	Animal & Plant Life Cycle Cards	<input type="checkbox"/>	<input type="checkbox"/>
		1	E-109	Solar System Model	<input type="checkbox"/>	<input type="checkbox"/>
		1	E-110	Weather Station	<input type="checkbox"/>	<input type="checkbox"/>
		1	E-111	Weather Reporting Camera	<input type="checkbox"/>	<input type="checkbox"/>
		1	E-112	Weather Reporting Board	<input type="checkbox"/>	<input type="checkbox"/>
		1	E-113	Camera	<input type="checkbox"/>	<input type="checkbox"/>
		2	E-114	Work Bench	<input type="checkbox"/>	<input type="checkbox"/>
		1	E-115	Tool Storage	<input type="checkbox"/>	<input type="checkbox"/>
		1	E-116	Storage Bins	<input type="checkbox"/>	<input type="checkbox"/>
		1	E-117	Floor Lamp	<input type="checkbox"/>	<input type="checkbox"/>
		2	E-118	Water & Sand Table	<input type="checkbox"/>	<input type="checkbox"/>
		1	E-119	Rolling Cart	<input type="checkbox"/>	<input type="checkbox"/>
		1	E-120	Weather Station Software	<input type="checkbox"/>	<input type="checkbox"/>
		1	E-121	Weather Station Mounting Tripod	<input type="checkbox"/>	<input type="checkbox"/>
		1	E-122	Work Table	<input type="checkbox"/>	<input type="checkbox"/>
		1	E-123	Poster Cabinet	<input type="checkbox"/>	<input type="checkbox"/>
		1	E-124	Grow Lab	<input type="checkbox"/>	<input type="checkbox"/>
		1	E-125	Planting Center	<input type="checkbox"/>	<input type="checkbox"/>
		1	E-127	Rug 1	<input type="checkbox"/>	<input type="checkbox"/>
		1	E-128	Rug 2	<input type="checkbox"/>	<input type="checkbox"/>
		1	E-129	Demo Storage Cart	<input type="checkbox"/>	<input type="checkbox"/>
		2	E-130	Demo Lab Table	<input type="checkbox"/>	<input type="checkbox"/>
		3	E-135	Rolling Wire Shelves	<input type="checkbox"/>	<input type="checkbox"/>
		1	E-136	Wire Shelving	<input type="checkbox"/>	<input type="checkbox"/>

ROOM NUMBER	ROOM NAME	QTY	Type	Type Comments	ELIGIBILITY	
		4	E-137	Wire Shelving Covers	<input type="checkbox"/>	<input type="checkbox"/>
		16	E-138	Wire Shelving Casters	<input type="checkbox"/>	<input type="checkbox"/>
		3	E-139	Recycle Bins	<input type="checkbox"/>	<input type="checkbox"/>
		1	E-140	Laptop/ Document Camera Cart	<input type="checkbox"/>	<input type="checkbox"/>
		12	T-005	Adjustable Height Table	<input type="checkbox"/>	<input type="checkbox"/>
<b>B118A</b>						
<b>Science Classroom</b>						
		1	A-001	Wastebasket	<input type="checkbox"/>	<input type="checkbox"/>
		1	A-061	Recycle Container	<input type="checkbox"/>	<input type="checkbox"/>
		12	CH-004	4 th + 5th Grade Large Chairs	<input type="checkbox"/>	<input type="checkbox"/>
		1	E-051	Fish Tank Set Up 1	<input type="checkbox"/>	<input type="checkbox"/>
		1	E-058	Fish Tank Set Up 2	<input type="checkbox"/>	<input type="checkbox"/>
		4	T-002	Trapezoid Table	<input type="checkbox"/>	<input type="checkbox"/>
<b>B119</b>						
<b>Theater Support</b>						
		1	A-061	Recycle Container	<input type="checkbox"/>	<input type="checkbox"/>
		2	S-009	Storage Cabinet	<input type="checkbox"/>	<input type="checkbox"/>
<b>B122</b>						
<b>Immersive Theater</b>						
		110	CH-017	Immersive Theater Chairs	<input type="checkbox"/>	<input type="checkbox"/>
		10	E-095	Chair Dollies-Immersive	<input type="checkbox"/>	<input type="checkbox"/>
<b>B123</b>						
<b>Theater Support</b>						
		6	CH-007	Teacher Reading Chair	<input type="checkbox"/>	<input type="checkbox"/>
		4	S-014	Garment Racks	<input type="checkbox"/>	<input type="checkbox"/>
		3	T-011	Rectangular Tables	<input type="checkbox"/>	<input type="checkbox"/>
<b>B125</b>						
<b>Security Vestibule</b>						
		1	E-076	Heavy Duty Platform Truck	<input type="checkbox"/>	<input type="checkbox"/>
<b>B126</b>						
<b>Waiting/Reception</b>						
		2	A-001	Wastebasket	<input type="checkbox"/>	<input type="checkbox"/>
		1	A-006	USA Flag Exterior	<input type="checkbox"/>	<input type="checkbox"/>
		1	A-007	CT Exterior Flag	<input type="checkbox"/>	<input type="checkbox"/>
		2	A-008	Pencil Sharpener	<input type="checkbox"/>	<input type="checkbox"/>
		2	A-053	Die Cutter	<input type="checkbox"/>	<input type="checkbox"/>
		2	A-061	Recycle Container	<input type="checkbox"/>	<input type="checkbox"/>
		1	A-144	Large Paper Cutter	<input type="checkbox"/>	<input type="checkbox"/>



ROOM NUMBER	ROOM NAME	QTY	Type	Type Comments	ELIGIBILITY	
		2	CH-006	Teacher Chair	<input type="checkbox"/>	<input type="checkbox"/>
		10	CH-008	Waiting Chair	<input type="checkbox"/>	<input type="checkbox"/>
		1	D-006	Medium Private Office Desk	<input type="checkbox"/>	<input type="checkbox"/>
		12	E-031	Orange Cones	<input type="checkbox"/>	<input type="checkbox"/>
		1	E-093	Shredder	<input type="checkbox"/>	<input type="checkbox"/>
		12	E-094	Walkie Talkies	<input type="checkbox"/>	<input type="checkbox"/>
		4	F-003	Wood Lateral	<input type="checkbox"/>	<input type="checkbox"/>
		1	S-013	Safe	<input type="checkbox"/>	<input type="checkbox"/>
<b>B129</b>						
	<b>Storage</b>					
		3	S-001	Metal Shelving	<input type="checkbox"/>	<input type="checkbox"/>
<b>B130</b>						
	<b>Toliet</b>					
		1	A-001	Wastebasket	<input type="checkbox"/>	<input type="checkbox"/>
<b>B131</b>						
	<b>Toliet</b>					
		1	A-001	Wastebasket	<input type="checkbox"/>	<input type="checkbox"/>
<b>B132</b>						
	<b>Principal Office</b>					
		1	A-001	Wastebasket	<input type="checkbox"/>	<input type="checkbox"/>
		1	A-061	Recycle Container	<input type="checkbox"/>	<input type="checkbox"/>
		1	CH-006	Teacher Chair	<input type="checkbox"/>	<input type="checkbox"/>
		2	CH-008	Waiting Chair	<input type="checkbox"/>	<input type="checkbox"/>
		1	D-005	Large Private Office Desk	<input type="checkbox"/>	<input type="checkbox"/>
		2	S-015	Classroom Bookcase	<input type="checkbox"/>	<input type="checkbox"/>
		2	S-016	Wooden Shelving	<input type="checkbox"/>	<input type="checkbox"/>
<b>B133</b>						
	<b>Workroom</b>					
		1	A-141	Calandar White Board	<input type="checkbox"/>	<input type="checkbox"/>
		1	E-142	Refridgerator	<input type="checkbox"/>	<input type="checkbox"/>
<b>B134</b>						
	<b>Reading Room</b>					
		1	A-001	Wastebasket	<input type="checkbox"/>	<input type="checkbox"/>
		1	A-002	Classroom Flag	<input type="checkbox"/>	<input type="checkbox"/>
		1	A-008	Pencil Sharpener	<input type="checkbox"/>	<input type="checkbox"/>
		1	A-019	Wheasel	<input type="checkbox"/>	<input type="checkbox"/>
		4	A-023	Groupwork Screen	<input type="checkbox"/>	<input type="checkbox"/>
		1	A-061	Recycle Container	<input type="checkbox"/>	<input type="checkbox"/>

ROOM NUMBER	ROOM NAME	QTY	Type	Type Comments	ELIGIBILITY	
		12	A-145	Large Book Baskets	<input type="checkbox"/>	<input type="checkbox"/>
		12	A-146	Medium Book Basket	<input type="checkbox"/>	<input type="checkbox"/>
		14	CH-002	K + 1st Grade Small Chairs	<input type="checkbox"/>	<input type="checkbox"/>
		2	CH-006	Teacher Chair	<input type="checkbox"/>	<input type="checkbox"/>
		4	CH-007	Teacher Reading Chair	<input type="checkbox"/>	<input type="checkbox"/>
		2	D-003L	Teacher's Classroom Desk	<input type="checkbox"/>	<input type="checkbox"/>
		6	S-015	Classroom Bookcase	<input type="checkbox"/>	<input type="checkbox"/>
		2	T-002	Trapezoid Table	<input type="checkbox"/>	<input type="checkbox"/>
		1	T-003	Kidney Table	<input type="checkbox"/>	<input type="checkbox"/>
		1	T-006	Computer Tables	<input type="checkbox"/>	<input type="checkbox"/>
		1	T-007	ADA Compliant Tables	<input type="checkbox"/>	<input type="checkbox"/>
<b>B135</b>						
	<b>Storage</b>					
		4	S-001	Metal Shelving	<input type="checkbox"/>	<input type="checkbox"/>
<b>B136</b>						
	<b>Storage</b>					
		4	S-001	Metal Shelving	<input type="checkbox"/>	<input type="checkbox"/>
<b>B137</b>						
	<b>Toilet</b>					
		1	A-001	Wastebasket	<input type="checkbox"/>	<input type="checkbox"/>
<b>B138</b>						
	<b>1st Grade</b>					
		1	A-001	Wastebasket	<input type="checkbox"/>	<input type="checkbox"/>
		1	A-002	Classroom Flag	<input type="checkbox"/>	<input type="checkbox"/>
		1	A-008	Pencil Sharpener	<input type="checkbox"/>	<input type="checkbox"/>
		1	A-010	1st Grade Rug	<input type="checkbox"/>	<input type="checkbox"/>
		1	A-018	Folder & Tray Cubby Mail Slots	<input type="checkbox"/>	<input type="checkbox"/>
		1	A-019	Wheasel	<input type="checkbox"/>	<input type="checkbox"/>
		1	A-061	Recycle Container	<input type="checkbox"/>	<input type="checkbox"/>
		24	A-063	Mini-White Boards	<input type="checkbox"/>	<input type="checkbox"/>
		1	A-065	Map Pack 2- Grades 1+2	<input type="checkbox"/>	<input type="checkbox"/>
		12	A-145	Large Book Baskets	<input type="checkbox"/>	<input type="checkbox"/>
		12	A-146	Medium Book Basket	<input type="checkbox"/>	<input type="checkbox"/>
		35	CH-002	K + 1st Grade Small Chairs	<input type="checkbox"/>	<input type="checkbox"/>
		1	CH-006	Teacher Chair	<input type="checkbox"/>	<input type="checkbox"/>
		2	CH-007	Teacher Reading Chair	<input type="checkbox"/>	<input type="checkbox"/>
		1	D-003L	Teacher's Classroom Desk	<input type="checkbox"/>	<input type="checkbox"/>
		1	E-140	Laptop/ Document Camera Cart	<input type="checkbox"/>	<input type="checkbox"/>

ROOM NUMBER	ROOM NAME	QTY	Type	Type Comments	ELIGIBILITY	
		6	S-002	Classroom Bookcase	<input type="checkbox"/>	<input type="checkbox"/>
		1	S-003	Big Book Display	<input type="checkbox"/>	<input type="checkbox"/>
		3	S-004	Mobile Cubby Unit	<input type="checkbox"/>	<input type="checkbox"/>
		5	T-001	Round Table	<input type="checkbox"/>	<input type="checkbox"/>
		2	T-002	Trapezoid Table	<input type="checkbox"/>	<input type="checkbox"/>
		1	T-003	Kidney Table	<input type="checkbox"/>	<input type="checkbox"/>
		1	T-004	Small Table	<input type="checkbox"/>	<input type="checkbox"/>
		2	T-006	Computer Tables	<input type="checkbox"/>	<input type="checkbox"/>
		1	T-007	ADA Compliant Tables	<input type="checkbox"/>	<input type="checkbox"/>
<b>B139</b>						
	<b>Principal Conference</b>					
		1	A-001	Wastebasket	<input type="checkbox"/>	<input type="checkbox"/>
		8	CH-010	Conference Chairs	<input type="checkbox"/>	<input type="checkbox"/>
		1	T-016	Boat Shaped Conference Table	<input type="checkbox"/>	<input type="checkbox"/>
<b>B140</b>						
	<b>Nurse Suite</b>					
		1	A-056	Bulletin Board	<input type="checkbox"/>	<input type="checkbox"/>
		1	A-142	Foot Stool with Handle	<input type="checkbox"/>	<input type="checkbox"/>
		1	A-143	White Board	<input type="checkbox"/>	<input type="checkbox"/>
		1	CH-006	Teacher Chair	<input type="checkbox"/>	<input type="checkbox"/>
		2	CH-007	Teacher Reading Chair	<input type="checkbox"/>	<input type="checkbox"/>
		2	CH-015	Recovery Couch	<input type="checkbox"/>	<input type="checkbox"/>
		1	CH-016	Exam Stool	<input type="checkbox"/>	<input type="checkbox"/>
		1	D-006	Medium Private Office Desk	<input type="checkbox"/>	<input type="checkbox"/>
		1	E-078	Refridgerator	<input type="checkbox"/>	<input type="checkbox"/>
		1	E-082	Large Narcotic Cabinet	<input type="checkbox"/>	<input type="checkbox"/>
		1	E-083	First Aid Wall Cabinet	<input type="checkbox"/>	<input type="checkbox"/>
		1	E-084	Emergency Kit	<input type="checkbox"/>	<input type="checkbox"/>
		1	E-085	Maico Audiometer	<input type="checkbox"/>	<input type="checkbox"/>
		1	E-086	Titmus V4 General Testing Model	<input type="checkbox"/>	<input type="checkbox"/>
		1	E-087	School Health Wheel Chair	<input type="checkbox"/>	<input type="checkbox"/>
		2	E-088	Zoll AED Plus Defibulator	<input type="checkbox"/>	<input type="checkbox"/>
		1	E-089	Welch Allyn Spot Vital Signs	<input type="checkbox"/>	<input type="checkbox"/>
		1	E-090	Stand Alone Mobile Cabinet w/ Lock	<input type="checkbox"/>	<input type="checkbox"/>
		1	E-091	Stand alone wall mounted Digital Hei	<input type="checkbox"/>	<input type="checkbox"/>
		1	E-092	Faucet Mounted Eye Wash System	<input type="checkbox"/>	<input type="checkbox"/>
		1	S-011	2 Drawer	<input type="checkbox"/>	<input type="checkbox"/>
		1	S-016	Wooden Shelving	<input type="checkbox"/>	<input type="checkbox"/>

ROOM NUMBER	ROOM NAME	QTY	Type	Type Comments	ELIGIBILITY	
<b>B141</b>						
<b>Storage</b>						
		1	S-016	Wooden Shelving	<input type="checkbox"/>	<input type="checkbox"/>
<b>B201</b>						
<b>3rd Grade</b>						
		1	A-001	Wastebasket	<input type="checkbox"/>	<input type="checkbox"/>
		1	A-002	Classroom Flag	<input type="checkbox"/>	<input type="checkbox"/>
		1	A-008	Pencil Sharpener	<input type="checkbox"/>	<input type="checkbox"/>
		1	A-012	3rd Grade Rug	<input type="checkbox"/>	<input type="checkbox"/>
		1	A-018	Folder & Tray Cubby Mail Slots	<input type="checkbox"/>	<input type="checkbox"/>
		1	A-019	Wheasel	<input type="checkbox"/>	<input type="checkbox"/>
		1	A-061	Recycle Container	<input type="checkbox"/>	<input type="checkbox"/>
		24	A-063	Mini-White Boards	<input type="checkbox"/>	<input type="checkbox"/>
		1	A-066	Map Pack 3-Grades 3+4	<input type="checkbox"/>	<input type="checkbox"/>
		12	A-145	Large Book Baskets	<input type="checkbox"/>	<input type="checkbox"/>
		12	A-146	Medium Book Basket	<input type="checkbox"/>	<input type="checkbox"/>
		35	CH-003	2nd + 3rd Grade Medium Chairs	<input type="checkbox"/>	<input type="checkbox"/>
		1	CH-006	Teacher Chair	<input type="checkbox"/>	<input type="checkbox"/>
		2	CH-007	Teacher Reading Chair	<input type="checkbox"/>	<input type="checkbox"/>
		23	D-001	Student Desk w/ Book Basket Box	<input type="checkbox"/>	<input type="checkbox"/>
		1	D-002	ADA Compliant Student Desk	<input type="checkbox"/>	<input type="checkbox"/>
		1	D-003L	Teacher's Classroom Desk	<input type="checkbox"/>	<input type="checkbox"/>
		1	E-140	Laptop/ Document Camera Cart	<input type="checkbox"/>	<input type="checkbox"/>
		3	S-004	Mobile Cubby Unit	<input type="checkbox"/>	<input type="checkbox"/>
		3	S-015	Classroom Bookcase	<input type="checkbox"/>	<input type="checkbox"/>
		3	S-018	Classroom Bookcase	<input type="checkbox"/>	<input type="checkbox"/>
		1	T-003	Kidney Table	<input type="checkbox"/>	<input type="checkbox"/>
		1	T-004	Small Table	<input type="checkbox"/>	<input type="checkbox"/>
		2	T-006	Computer Tables	<input type="checkbox"/>	<input type="checkbox"/>
		1	T-007	ADA Compliant Tables	<input type="checkbox"/>	<input type="checkbox"/>
		1	T-010	Round Student Tables	<input type="checkbox"/>	<input type="checkbox"/>
<b>B202</b>						
<b>2nd Grade</b>						
		1	A-001	Wastebasket	<input type="checkbox"/>	<input type="checkbox"/>
		1	A-002	Classroom Flag	<input type="checkbox"/>	<input type="checkbox"/>
		1	A-008	Pencil Sharpener	<input type="checkbox"/>	<input type="checkbox"/>
		1	A-011	2nd Grade Rug	<input type="checkbox"/>	<input type="checkbox"/>
		1	A-018	Folder & Tray Cubby Mail Slots	<input type="checkbox"/>	<input type="checkbox"/>

ROOM NUMBER	ROOM NAME	QTY	Type	Type Comments	ELIGIBILITY	
		1	A-019	Wheasel	<input type="checkbox"/>	<input type="checkbox"/>
		1	A-061	Recycle Container	<input type="checkbox"/>	<input type="checkbox"/>
		24	A-063	Mini-White Boards	<input type="checkbox"/>	<input type="checkbox"/>
		1	A-065	Map Pack 2- Grades 1+2	<input type="checkbox"/>	<input type="checkbox"/>
		12	A-145	Large Book Baskets	<input type="checkbox"/>	<input type="checkbox"/>
		12	A-146	Medium Book Basket	<input type="checkbox"/>	<input type="checkbox"/>
		35	CH-003	2nd + 3rd Grade Medium Chairs	<input type="checkbox"/>	<input type="checkbox"/>
		1	CH-006	Teacher Chair	<input type="checkbox"/>	<input type="checkbox"/>
		2	CH-007	Teacher Reading Chair	<input type="checkbox"/>	<input type="checkbox"/>
		24	D-001	Student Desk w/ Book Basket Box	<input type="checkbox"/>	<input type="checkbox"/>
		1	D-002	ADA Compliant Student Desk	<input type="checkbox"/>	<input type="checkbox"/>
		1	D-003R	Teacher's Classroom Desk	<input type="checkbox"/>	<input type="checkbox"/>
		1	E-140	Laptop/ Document Camera Cart	<input type="checkbox"/>	<input type="checkbox"/>
		3	S-004	Mobile Cubby Unit	<input type="checkbox"/>	<input type="checkbox"/>
		3	S-015	Classroom Bookcase	<input type="checkbox"/>	<input type="checkbox"/>
		2	S-018	Classroom Bookcase	<input type="checkbox"/>	<input type="checkbox"/>
		1	T-003	Kidney Table	<input type="checkbox"/>	<input type="checkbox"/>
		1	T-004	Small Table	<input type="checkbox"/>	<input type="checkbox"/>
		2	T-006	Computer Tables	<input type="checkbox"/>	<input type="checkbox"/>
		1	T-007	ADA Compliant Tables	<input type="checkbox"/>	<input type="checkbox"/>
		1	T-010	Round Student Tables	<input type="checkbox"/>	<input type="checkbox"/>

**B204**

**2nd Grade**

		1	A-001	Wastebasket	<input type="checkbox"/>	<input type="checkbox"/>
		1	A-002	Classroom Flag	<input type="checkbox"/>	<input type="checkbox"/>
		1	A-008	Pencil Sharpener	<input type="checkbox"/>	<input type="checkbox"/>
		1	A-011	2nd Grade Rug	<input type="checkbox"/>	<input type="checkbox"/>
		1	A-018	Folder & Tray Cubby Mail Slots	<input type="checkbox"/>	<input type="checkbox"/>
		1	A-019	Wheasel	<input type="checkbox"/>	<input type="checkbox"/>
		1	A-061	Recycle Container	<input type="checkbox"/>	<input type="checkbox"/>
		24	A-063	Mini-White Boards	<input type="checkbox"/>	<input type="checkbox"/>
		1	A-065	Map Pack 2- Grades 1+2	<input type="checkbox"/>	<input type="checkbox"/>
		12	A-145	Large Book Baskets	<input type="checkbox"/>	<input type="checkbox"/>
		12	A-146	Medium Book Basket	<input type="checkbox"/>	<input type="checkbox"/>
		35	CH-003	2nd + 3rd Grade Medium Chairs	<input type="checkbox"/>	<input type="checkbox"/>
		1	CH-006	Teacher Chair	<input type="checkbox"/>	<input type="checkbox"/>
		2	CH-007	Teacher Reading Chair	<input type="checkbox"/>	<input type="checkbox"/>
		23	D-001	Student Desk w/ Book Basket Box	<input type="checkbox"/>	<input type="checkbox"/>

ROOM NUMBER	ROOM NAME	QTY	Type	Type Comments	ELIGIBILITY	
		1	D-002	ADA Compliant Student Desk	<input type="checkbox"/>	<input type="checkbox"/>
		1	D-003L	Teacher's Classroom Desk	<input type="checkbox"/>	<input type="checkbox"/>
		1	E-140	Laptop/ Document Camera Cart	<input type="checkbox"/>	<input type="checkbox"/>
		3	S-004	Mobile Cubby Unit	<input type="checkbox"/>	<input type="checkbox"/>
		3	S-015	Classroom Bookcase	<input type="checkbox"/>	<input type="checkbox"/>
		2	S-018	Classroom Bookcase	<input type="checkbox"/>	<input type="checkbox"/>
		1	T-003	Kidney Table	<input type="checkbox"/>	<input type="checkbox"/>
		1	T-004	Small Table	<input type="checkbox"/>	<input type="checkbox"/>
		2	T-006	Computer Tables	<input type="checkbox"/>	<input type="checkbox"/>
		1	T-007	ADA Compliant Tables	<input type="checkbox"/>	<input type="checkbox"/>
		1	T-010	Round Student Tables	<input type="checkbox"/>	<input type="checkbox"/>

**B205**

**3rd Grade**

		1	A-001	Wastebasket	<input type="checkbox"/>	<input type="checkbox"/>
		1	A-002	Classroom Flag	<input type="checkbox"/>	<input type="checkbox"/>
		1	A-008	Pencil Sharpener	<input type="checkbox"/>	<input type="checkbox"/>
		1	A-012	3rd Grade Rug	<input type="checkbox"/>	<input type="checkbox"/>
		1	A-018	Folder & Tray Cubby Mail Slots	<input type="checkbox"/>	<input type="checkbox"/>
		1	A-019	Wheasel	<input type="checkbox"/>	<input type="checkbox"/>
		1	A-061	Recycle Container	<input type="checkbox"/>	<input type="checkbox"/>
		24	A-063	Mini-White Boards	<input type="checkbox"/>	<input type="checkbox"/>
		1	A-066	Map Pack 3-Grades 3+4	<input type="checkbox"/>	<input type="checkbox"/>
		12	A-145	Large Book Baskets	<input type="checkbox"/>	<input type="checkbox"/>
		12	A-146	Medium Book Basket	<input type="checkbox"/>	<input type="checkbox"/>
		35	CH-003	2nd + 3rd Grade Medium Chairs	<input type="checkbox"/>	<input type="checkbox"/>
		1	CH-006	Teacher Chair	<input type="checkbox"/>	<input type="checkbox"/>
		2	CH-007	Teacher Reading Chair	<input type="checkbox"/>	<input type="checkbox"/>
		23	D-001	Student Desk w/ Book Basket Box	<input type="checkbox"/>	<input type="checkbox"/>
		1	D-002	ADA Compliant Student Desk	<input type="checkbox"/>	<input type="checkbox"/>
		1	D-003R	Teacher's Classroom Desk	<input type="checkbox"/>	<input type="checkbox"/>
		1	E-140	Laptop/ Document Camera Cart	<input type="checkbox"/>	<input type="checkbox"/>
		3	S-004	Mobile Cubby Unit	<input type="checkbox"/>	<input type="checkbox"/>
		3	S-015	Classroom Bookcase	<input type="checkbox"/>	<input type="checkbox"/>
		3	S-018	Classroom Bookcase	<input type="checkbox"/>	<input type="checkbox"/>
		1	T-003	Kidney Table	<input type="checkbox"/>	<input type="checkbox"/>
		1	T-004	Small Table	<input type="checkbox"/>	<input type="checkbox"/>
		2	T-006	Computer Tables	<input type="checkbox"/>	<input type="checkbox"/>
		1	T-007	ADA Compliant Tables	<input type="checkbox"/>	<input type="checkbox"/>

ROOM NUMBER	ROOM NAME	QTY	Type	Type Comments	ELIGIBILITY	
		1	T-010	Round Student Tables	<input type="checkbox"/>	<input type="checkbox"/>
<b>B206</b>						
<b>Teacher Resource/Dinning Roo</b>						
		3	A-001	Wastebasket	<input type="checkbox"/>	<input type="checkbox"/>
		1	A-060	55 Gallon Brute Trash Can w/ Dolly	<input type="checkbox"/>	<input type="checkbox"/>
		1	A-061	Recycle Container	<input type="checkbox"/>	<input type="checkbox"/>
		24	CH-007	Teacher Reading Chair	<input type="checkbox"/>	<input type="checkbox"/>
		1	CH-011	Couch	<input type="checkbox"/>	<input type="checkbox"/>
		2	CH-012	Arm Chairs	<input type="checkbox"/>	<input type="checkbox"/>
		1	E-079	Microwave	<input type="checkbox"/>	<input type="checkbox"/>
		1	E-142	Refridgerator	<input type="checkbox"/>	<input type="checkbox"/>
		6	S-002	Classroom Bookcase	<input type="checkbox"/>	<input type="checkbox"/>
		2	S-010	Flat File Cabinet	<input type="checkbox"/>	<input type="checkbox"/>
		4	T-011	Rectangular Tables	<input type="checkbox"/>	<input type="checkbox"/>
<b>B214</b>						
<b>Admin Office</b>						
		1	A-001	Wastebasket	<input type="checkbox"/>	<input type="checkbox"/>
		1	A-061	Recycle Container	<input type="checkbox"/>	<input type="checkbox"/>
		4	CH-004	4 th + 5th Grade Large Chairs	<input type="checkbox"/>	<input type="checkbox"/>
		1	CH-006	Teacher Chair	<input type="checkbox"/>	<input type="checkbox"/>
		2	CH-007	Teacher Reading Chair	<input type="checkbox"/>	<input type="checkbox"/>
		5	S-015	Classroom Bookcase	<input type="checkbox"/>	<input type="checkbox"/>
		2	T-002	Trapezoid Table	<input type="checkbox"/>	<input type="checkbox"/>
<b>B215</b>						
<b>Custodial Closet</b>						
		2	A-059	Trash Containers Corridor	<input type="checkbox"/>	<input type="checkbox"/>
		4	A-062	Mop Buckets	<input type="checkbox"/>	<input type="checkbox"/>
		4	E-061	Vacuum Backpack	<input type="checkbox"/>	<input type="checkbox"/>
		1	E-062	Carpet Cleaner	<input type="checkbox"/>	<input type="checkbox"/>
		1	E-063	Boom Lift- Electric	<input type="checkbox"/>	<input type="checkbox"/>
		1	E-064	Wet/Dry Vacuum	<input type="checkbox"/>	<input type="checkbox"/>
		1	E-065	Floor Scrubber	<input type="checkbox"/>	<input type="checkbox"/>
		1	E-066	Floor Machine	<input type="checkbox"/>	<input type="checkbox"/>
		1	E-067	Floor Burnisher	<input type="checkbox"/>	<input type="checkbox"/>
		1	E-068	Snow Blower	<input type="checkbox"/>	<input type="checkbox"/>
		1	E-069	Cleaning System	<input type="checkbox"/>	<input type="checkbox"/>
		1	E-070	Electric Pressure Washer	<input type="checkbox"/>	<input type="checkbox"/>
		1	E-071	Heat Buster Fan	<input type="checkbox"/>	<input type="checkbox"/>

ROOM NUMBER	ROOM NAME	QTY	Type	Type Comments	ELIGIBILITY	
		1	E-072	Carpet Dryer	<input type="checkbox"/>	<input type="checkbox"/>
		1	E-073	Six Foot Fiber Glass Step Ladder	<input type="checkbox"/>	<input type="checkbox"/>
		1	E-074	Eight Foot Fiber Glass Step Ladder	<input type="checkbox"/>	<input type="checkbox"/>
		1	E-075	Standard Hand Truck	<input type="checkbox"/>	<input type="checkbox"/>
		1	E-133	Pallet Jack	<input type="checkbox"/>	<input type="checkbox"/>
		1	S-001	Metal Shelving	<input type="checkbox"/>	<input type="checkbox"/>
<b>C101</b>						
<b>Gymnasium</b>						
		1	A-019	Wheasel	<input type="checkbox"/>	<input type="checkbox"/>
		2	A-056	Bulletin Board	<input type="checkbox"/>	<input type="checkbox"/>
		12	A-057	Totes	<input type="checkbox"/>	<input type="checkbox"/>
		1	A-058	Ball Racks	<input type="checkbox"/>	<input type="checkbox"/>
		2	A-060	55 Gallon Brute Trash Can w/ Dolly	<input type="checkbox"/>	<input type="checkbox"/>
		1	A-119	Cutting Boards	<input type="checkbox"/>	<input type="checkbox"/>
		25	E-024	Junior Basketballs	<input type="checkbox"/>	<input type="checkbox"/>
		4	E-025	Playground Balls	<input type="checkbox"/>	<input type="checkbox"/>
		1	E-026	Softtouch Hockey Sticks	<input type="checkbox"/>	<input type="checkbox"/>
		1	E-027	Hockey Hotballs	<input type="checkbox"/>	<input type="checkbox"/>
		5	E-028	Uncoated Foam Balls	<input type="checkbox"/>	<input type="checkbox"/>
		8	E-029	Rainbow Plastic Cones	<input type="checkbox"/>	<input type="checkbox"/>
		1	E-030	Half Cones	<input type="checkbox"/>	<input type="checkbox"/>
		18	E-031	Orange Cones	<input type="checkbox"/>	<input type="checkbox"/>
		7	E-032	Balance Board	<input type="checkbox"/>	<input type="checkbox"/>
		14	E-033	Scrimmage Vests	<input type="checkbox"/>	<input type="checkbox"/>
		1	E-034	Volleyball Net	<input type="checkbox"/>	<input type="checkbox"/>
		1	E-035	Ball Inflator	<input type="checkbox"/>	<input type="checkbox"/>
		1	E-036	Poly Spot Markers	<input type="checkbox"/>	<input type="checkbox"/>
		2	E-037	Poly Spot Markers 9"	<input type="checkbox"/>	<input type="checkbox"/>
		8	E-038	Jump Rope x2 Dutch	<input type="checkbox"/>	<input type="checkbox"/>
		30	E-039	Jump ropes	<input type="checkbox"/>	<input type="checkbox"/>
		2	E-040	Chinese Jump Ropes	<input type="checkbox"/>	<input type="checkbox"/>
		24	E-041	Pulse Monitors	<input type="checkbox"/>	<input type="checkbox"/>
		4	E-042	Pulse Monitors	<input type="checkbox"/>	<input type="checkbox"/>
		1	E-043	CD /Tape Player	<input type="checkbox"/>	<input type="checkbox"/>
		1	E-044	Voice Blaster	<input type="checkbox"/>	<input type="checkbox"/>
		2	E-045	Mats-1	<input type="checkbox"/>	<input type="checkbox"/>
		14	E-046	Mats-2	<input type="checkbox"/>	<input type="checkbox"/>
		1	E-047	Mats-3	<input type="checkbox"/>	<input type="checkbox"/>



ROOM NUMBER	ROOM NAME	QTY	Type	Type Comments	ELIGIBILITY	
		1	E-048	Mat Cart	<input type="checkbox"/>	<input type="checkbox"/>
		2	E-049	Pull Up Bars	<input type="checkbox"/>	<input type="checkbox"/>
		1	E-050	Power Climbers	<input type="checkbox"/>	<input type="checkbox"/>
		2	E-052	Playground Balls	<input type="checkbox"/>	<input type="checkbox"/>
		9	E-053	Basketballs	<input type="checkbox"/>	<input type="checkbox"/>
		9	E-054	Basketballs	<input type="checkbox"/>	<input type="checkbox"/>
		9	E-055	Basketballs	<input type="checkbox"/>	<input type="checkbox"/>
		10	E-056	Hula Hoops	<input type="checkbox"/>	<input type="checkbox"/>
		1	E-057	Mesh Bags for Vests	<input type="checkbox"/>	<input type="checkbox"/>
		9	E-059	Nerf Footballs	<input type="checkbox"/>	<input type="checkbox"/>
		2	E-060	Outdoor Basketball Hoop Nets	<input type="checkbox"/>	<input type="checkbox"/>
		2	E-141	Lecturn	<input type="checkbox"/>	<input type="checkbox"/>
		2	S-007	Rolling Utility Cart	<input type="checkbox"/>	<input type="checkbox"/>
<b>C102</b>						
	<b>Storage</b>					
		300	CH-009	Stack Chair	<input type="checkbox"/>	<input type="checkbox"/>
		14	E-081	Chair Dolly	<input type="checkbox"/>	<input type="checkbox"/>
		6	S-008	Gym/PE Storage	<input type="checkbox"/>	<input type="checkbox"/>
<b>C103</b>						
	<b>Platform</b>					
		1	A-003	USA Flag on Pole	<input type="checkbox"/>	<input type="checkbox"/>
		1	A-004	CT Flag on Pole	<input type="checkbox"/>	<input type="checkbox"/>
<b>C104</b>						
	<b>PE Office</b>					
		1	A-001	Wastebasket	<input type="checkbox"/>	<input type="checkbox"/>
		1	CH-006	Teacher Chair	<input type="checkbox"/>	<input type="checkbox"/>
		1	D-004	Small Private Office Desk	<input type="checkbox"/>	<input type="checkbox"/>
		1	F-002	File Shuttle & Companion File	<input type="checkbox"/>	<input type="checkbox"/>
		2	S-007	Rolling Utility Cart	<input type="checkbox"/>	<input type="checkbox"/>
		2	S-009	Storage Cabinet	<input type="checkbox"/>	<input type="checkbox"/>
<b>C105</b>						
	<b>Storage</b>					
		4	S-008	Gym/PE Storage	<input type="checkbox"/>	<input type="checkbox"/>
<b>C108</b>						
	<b>Global Studies Classroom</b>					
		1	A-001	Wastebasket	<input type="checkbox"/>	<input type="checkbox"/>
		1	A-002	Classroom Flag	<input type="checkbox"/>	<input type="checkbox"/>
		1	A-008	Pencil Sharpener	<input type="checkbox"/>	<input type="checkbox"/>

ROOM NUMBER	ROOM NAME	QTY	Type	Type Comments	ELIGIBILITY	
		1	A-015	Japanese Rug	<input type="checkbox"/>	<input type="checkbox"/>
		1	A-061	Recycle Container	<input type="checkbox"/>	<input type="checkbox"/>
		24	A-063	Mini-White Boards	<input type="checkbox"/>	<input type="checkbox"/>
		1	A-067	Map Pack 4- Grade 5	<input type="checkbox"/>	<input type="checkbox"/>
		35	CH-004	4 th + 5th Grade Large Chairs	<input type="checkbox"/>	<input type="checkbox"/>
		1	CH-006	Teacher Chair	<input type="checkbox"/>	<input type="checkbox"/>
		2	CH-007	Teacher Reading Chair	<input type="checkbox"/>	<input type="checkbox"/>
		24	D-001	Student Desk w/ Book Basket Box	<input type="checkbox"/>	<input type="checkbox"/>
		1	D-002	ADA Compliant Student Desk	<input type="checkbox"/>	<input type="checkbox"/>
		1	D-003R	Teacher's Classroom Desk	<input type="checkbox"/>	<input type="checkbox"/>
		2	E-022	Rice Cooker	<input type="checkbox"/>	<input type="checkbox"/>
		2	E-023	Water Heater	<input type="checkbox"/>	<input type="checkbox"/>
		1	E-140	Laptop/ Document Camera Cart	<input type="checkbox"/>	<input type="checkbox"/>
		2	T-006	Computer Tables	<input type="checkbox"/>	<input type="checkbox"/>
		1	T-007	ADA Compliant Tables	<input type="checkbox"/>	<input type="checkbox"/>
		2	T-010	Round Student Tables	<input type="checkbox"/>	<input type="checkbox"/>
<b>C109</b>						
	<b>Global Studies Storage</b>					
		6	S-001	Metal Shelving	<input type="checkbox"/>	<input type="checkbox"/>
<b>C110</b>						
	<b>Art Storage &amp; Kiln</b>					
		5	A-001	Wastebasket	<input type="checkbox"/>	<input type="checkbox"/>
		1	A-030	Kiln Shelf	<input type="checkbox"/>	<input type="checkbox"/>
		50	A-031	Art Display Frames	<input type="checkbox"/>	<input type="checkbox"/>
		6	A-032	Storage Container w/ Lid	<input type="checkbox"/>	<input type="checkbox"/>
		24	A-033	Storage Bins	<input type="checkbox"/>	<input type="checkbox"/>
		6	A-034	Storage Container w/ Lid	<input type="checkbox"/>	<input type="checkbox"/>
		6	A-035	Storage Container w/ Lid	<input type="checkbox"/>	<input type="checkbox"/>
		6	S-001	Metal Shelving	<input type="checkbox"/>	<input type="checkbox"/>
<b>C111</b>						
	<b>Art Room</b>					
		1	A-002	Classroom Flag	<input type="checkbox"/>	<input type="checkbox"/>
		3	A-005	Large Garbage	<input type="checkbox"/>	<input type="checkbox"/>
		1	A-008	Pencil Sharpener	<input type="checkbox"/>	<input type="checkbox"/>
		1	A-017	Spec Ed Rug	<input type="checkbox"/>	<input type="checkbox"/>
		1	A-019	Wheasel	<input type="checkbox"/>	<input type="checkbox"/>
		1	A-024	Paper Roll Cutter	<input type="checkbox"/>	<input type="checkbox"/>
		1	A-025	Self Healing Mat	<input type="checkbox"/>	<input type="checkbox"/>

ROOM NUMBER	ROOM NAME	QTY	Type	Type Comments	ELIGIBILITY	
		6	A-026	Light Tracer	<input type="checkbox"/>	<input type="checkbox"/>
		1	A-027	Wood Easel	<input type="checkbox"/>	<input type="checkbox"/>
		1	A-028	Plastic Art Cart	<input type="checkbox"/>	<input type="checkbox"/>
		1	A-029	Ware Cart	<input type="checkbox"/>	<input type="checkbox"/>
		1	A-045	Rotary Trimmer	<input type="checkbox"/>	<input type="checkbox"/>
		1	A-046	Collapsible Cart	<input type="checkbox"/>	<input type="checkbox"/>
		2	A-060	55 Gallon Brute Trash Can w/ Dolly	<input type="checkbox"/>	<input type="checkbox"/>
		24	A-063	Mini-White Boards	<input type="checkbox"/>	<input type="checkbox"/>
		1	A-067	Map Pack 4- Grade 5	<input type="checkbox"/>	<input type="checkbox"/>
		5	CH-004	4 th + 5th Grade Large Chairs	<input type="checkbox"/>	<input type="checkbox"/>
		1	CH-006	Teacher Chair	<input type="checkbox"/>	<input type="checkbox"/>
		2	CH-007	Teacher Reading Chair	<input type="checkbox"/>	<input type="checkbox"/>
		30	CH-014	Classroom Stools	<input type="checkbox"/>	<input type="checkbox"/>
		1	D-003R	Teacher's Classroom Desk	<input type="checkbox"/>	<input type="checkbox"/>
		1	E-140	Laptop/ Document Camera Cart	<input type="checkbox"/>	<input type="checkbox"/>
		1	S-005	Cubby w/ Clear Trays	<input type="checkbox"/>	<input type="checkbox"/>
		1	S-006	Storage Unit	<input type="checkbox"/>	<input type="checkbox"/>
		2	T-006	Computer Tables	<input type="checkbox"/>	<input type="checkbox"/>
		1	T-007	ADA Compliant Tables	<input type="checkbox"/>	<input type="checkbox"/>
		6	T-014	Art Tables	<input type="checkbox"/>	<input type="checkbox"/>

**C112**

**Music Room**

		1	A-001	Wastebasket	<input type="checkbox"/>	<input type="checkbox"/>
		1	A-002	Classroom Flag	<input type="checkbox"/>	<input type="checkbox"/>
		1	A-008	Pencil Sharpener	<input type="checkbox"/>	<input type="checkbox"/>
		1	A-036	Equipment Cart	<input type="checkbox"/>	<input type="checkbox"/>
		13	A-037	Music Stand	<input type="checkbox"/>	<input type="checkbox"/>
		1	A-044	Music Board	<input type="checkbox"/>	<input type="checkbox"/>
		1	A-061	Recycle Container	<input type="checkbox"/>	<input type="checkbox"/>
		24	A-063	Mini-White Boards	<input type="checkbox"/>	<input type="checkbox"/>
		1	A-067	Map Pack 4- Grade 5	<input type="checkbox"/>	<input type="checkbox"/>
		11	CH-004	4 th + 5th Grade Large Chairs	<input type="checkbox"/>	<input type="checkbox"/>
		23	CH-005	Music Chair	<input type="checkbox"/>	<input type="checkbox"/>
		1	CH-006	Teacher Chair	<input type="checkbox"/>	<input type="checkbox"/>
		2	CH-007	Teacher Reading Chair	<input type="checkbox"/>	<input type="checkbox"/>
		1	D-002	ADA Compliant Student Desk	<input type="checkbox"/>	<input type="checkbox"/>
		1	D-003L	Teacher's Classroom Desk	<input type="checkbox"/>	<input type="checkbox"/>
		1	E-001	Keyboards	<input type="checkbox"/>	<input type="checkbox"/>

ROOM NUMBER	ROOM NAME	QTY	Type	Type Comments	ELIGIBILITY	
		1	E-002	RMP	<input type="checkbox"/>	<input type="checkbox"/>
		1	E-003	Orff Instruments	<input type="checkbox"/>	<input type="checkbox"/>
		1	E-004	Music Mallets	<input type="checkbox"/>	<input type="checkbox"/>
		1	E-005	Autoharp	<input type="checkbox"/>	<input type="checkbox"/>
		1	E-006	Block w/ Mallet	<input type="checkbox"/>	<input type="checkbox"/>
		1	E-007	Medium Wood Maracas	<input type="checkbox"/>	<input type="checkbox"/>
		1	E-008	Hand Bells	<input type="checkbox"/>	<input type="checkbox"/>
		1	E-009	Triangles	<input type="checkbox"/>	<input type="checkbox"/>
		1	E-010	Tambourine	<input type="checkbox"/>	<input type="checkbox"/>
		1	E-011	Tambourine	<input type="checkbox"/>	<input type="checkbox"/>
		1	E-012	Finger Cymbals	<input type="checkbox"/>	<input type="checkbox"/>
		1	E-013	Wooden Guiro	<input type="checkbox"/>	<input type="checkbox"/>
		1	E-014	Sound Shapes	<input type="checkbox"/>	<input type="checkbox"/>
		1	E-015	Kids Konga	<input type="checkbox"/>	<input type="checkbox"/>
		1	E-016	Kids Tubano	<input type="checkbox"/>	<input type="checkbox"/>
		1	E-017	Bean Bags	<input type="checkbox"/>	<input type="checkbox"/>
		1	E-018	5" Cymbals with Mallets	<input type="checkbox"/>	<input type="checkbox"/>
		1	E-019	Rhythm Stick Kit	<input type="checkbox"/>	<input type="checkbox"/>
		1	E-020	Eggz Shakers	<input type="checkbox"/>	<input type="checkbox"/>
		1	E-021	Upright Acoustic Piano with Bench	<input type="checkbox"/>	<input type="checkbox"/>
		1	E-140	Laptop/ Document Camera Cart	<input type="checkbox"/>	<input type="checkbox"/>
		8	S-002	Classroom Bookcase	<input type="checkbox"/>	<input type="checkbox"/>
		1	T-001	Round Table	<input type="checkbox"/>	<input type="checkbox"/>
		2	T-006	Computer Tables	<input type="checkbox"/>	<input type="checkbox"/>
		1	T-007	ADA Compliant Tables	<input type="checkbox"/>	<input type="checkbox"/>

**C118**

**Kitchen/Servery**

		2	A-070	Bread Slicing Knife	<input type="checkbox"/>	<input type="checkbox"/>
		2	A-071	French Cook Knife	<input type="checkbox"/>	<input type="checkbox"/>
		2	A-072	Cake Turner Blade	<input type="checkbox"/>	<input type="checkbox"/>
		2	A-073	Hamburger Turner	<input type="checkbox"/>	<input type="checkbox"/>
		4	A-074	Sandwich Spreader	<input type="checkbox"/>	<input type="checkbox"/>
		6	A-075	Paring Knife	<input type="checkbox"/>	<input type="checkbox"/>
		3	A-076	Vegetable Peeler	<input type="checkbox"/>	<input type="checkbox"/>
		4	A-077	All Purpose Disher 1	<input type="checkbox"/>	<input type="checkbox"/>
		2	A-078	All Purpose Disher 2	<input type="checkbox"/>	<input type="checkbox"/>
		2	A-079	All Purpose Disher 3	<input type="checkbox"/>	<input type="checkbox"/>
		2	A-080	All Purpose Disher 4	<input type="checkbox"/>	<input type="checkbox"/>

ROOM NUMBER	ROOM NAME	QTY	Type	Type Comments	ELIGIBILITY	
		3	A-081	SS Solid Basting Spoon	<input type="checkbox"/>	<input type="checkbox"/>
		3	A-082	Slotted Basting Spoon	<input type="checkbox"/>	<input type="checkbox"/>
		3	A-083	Perforated Basting spoon	<input type="checkbox"/>	<input type="checkbox"/>
		4	A-084	Ladle 1	<input type="checkbox"/>	<input type="checkbox"/>
		2	A-085	Ladle 2	<input type="checkbox"/>	<input type="checkbox"/>
		2	A-086	Ladle 3	<input type="checkbox"/>	<input type="checkbox"/>
		1	A-087	Cake Turner	<input type="checkbox"/>	<input type="checkbox"/>
		1	A-088	Funnel 1	<input type="checkbox"/>	<input type="checkbox"/>
		1	A-089	Funnel 2	<input type="checkbox"/>	<input type="checkbox"/>
		1	A-090	Scoop	<input type="checkbox"/>	<input type="checkbox"/>
		2	A-091	Measure Cap 1	<input type="checkbox"/>	<input type="checkbox"/>
		2	A-092	Measure Cap 2	<input type="checkbox"/>	<input type="checkbox"/>
		1	A-093	Measure Cap 3	<input type="checkbox"/>	<input type="checkbox"/>
		1	A-094	Steel Blade	<input type="checkbox"/>	<input type="checkbox"/>
		12	A-095	Steam Table Pan 1	<input type="checkbox"/>	<input type="checkbox"/>
		12	A-096	Steam Table Pan 2	<input type="checkbox"/>	<input type="checkbox"/>
		6	A-097	Steam Table Pan 3	<input type="checkbox"/>	<input type="checkbox"/>
		4	A-098	Steam Table Pan 4	<input type="checkbox"/>	<input type="checkbox"/>
		3	A-099	Steam Table Pan 5	<input type="checkbox"/>	<input type="checkbox"/>
		6	A-100	Steam Table Pan Cover 1	<input type="checkbox"/>	<input type="checkbox"/>
		6	A-101	Steam Table Pan Cover 2	<input type="checkbox"/>	<input type="checkbox"/>
		6	A-102	Steam Table Pan 6	<input type="checkbox"/>	<input type="checkbox"/>
		3	A-103	Steam Table Pan 7	<input type="checkbox"/>	<input type="checkbox"/>
		6	A-104	Steam Table Pan Cover 3	<input type="checkbox"/>	<input type="checkbox"/>
		2	A-105	Stream Table Pan 8	<input type="checkbox"/>	<input type="checkbox"/>
		2	A-106	Steam Table Pan 9	<input type="checkbox"/>	<input type="checkbox"/>
		4	A-107	Steam Table Pan Cover 4	<input type="checkbox"/>	<input type="checkbox"/>
		10	A-108	Steam Table Pan 10	<input type="checkbox"/>	<input type="checkbox"/>
		6	A-109	Tongs 1	<input type="checkbox"/>	<input type="checkbox"/>
		3	A-110	Tongs 2	<input type="checkbox"/>	<input type="checkbox"/>
		2	A-111	Piano Whips 1	<input type="checkbox"/>	<input type="checkbox"/>
		2	A-112	Piano Whips 2	<input type="checkbox"/>	<input type="checkbox"/>
		2	A-113	Mixing Bowl 1	<input type="checkbox"/>	<input type="checkbox"/>
		2	A-114	Mixing bowl 2	<input type="checkbox"/>	<input type="checkbox"/>
		2	A-115	Colander	<input type="checkbox"/>	<input type="checkbox"/>
		2	A-116	Sauce Pan 1	<input type="checkbox"/>	<input type="checkbox"/>
		2	A-117	Sauce Pan 2	<input type="checkbox"/>	<input type="checkbox"/>
		36	A-118	Sheet Pans	<input type="checkbox"/>	<input type="checkbox"/>

ROOM NUMBER	ROOM NAME	QTY	Type	Type Comments	ELIGIBILITY	
		4	A-119	Cutting Boards	<input type="checkbox"/>	<input type="checkbox"/>
		1	A-120	Electric Can Opener	<input type="checkbox"/>	<input type="checkbox"/>
		8	A-121	Thermometers	<input type="checkbox"/>	<input type="checkbox"/>
		2	A-122	Disher 5	<input type="checkbox"/>	<input type="checkbox"/>
		2	A-123	Ladle 4	<input type="checkbox"/>	<input type="checkbox"/>
		3	A-124	Basting Brush	<input type="checkbox"/>	<input type="checkbox"/>
		3	A-125	Rubber Spatulas	<input type="checkbox"/>	<input type="checkbox"/>
		4	A-126	Pizza Cutters	<input type="checkbox"/>	<input type="checkbox"/>
		12	A-127	Tongs 3	<input type="checkbox"/>	<input type="checkbox"/>
		4	A-128	Pocket Thermometers	<input type="checkbox"/>	<input type="checkbox"/>
		6	A-129	Grated Cheese Shakers	<input type="checkbox"/>	<input type="checkbox"/>
		12	A-130	Condiment Containers/ Squeeze Bottl	<input type="checkbox"/>	<input type="checkbox"/>
		4	A-131	Saddle Bag Dispensers	<input type="checkbox"/>	<input type="checkbox"/>
		1	A-132	Can Rack	<input type="checkbox"/>	<input type="checkbox"/>
		2	A-133	Utility Carts	<input type="checkbox"/>	<input type="checkbox"/>
		3	A-134	Open Sided Sheet Pan Rack	<input type="checkbox"/>	<input type="checkbox"/>
		4	A-135	Portion Server 1	<input type="checkbox"/>	<input type="checkbox"/>
		4	A-136	Portion Server 2	<input type="checkbox"/>	<input type="checkbox"/>
		4	A-137	Portion Server 3	<input type="checkbox"/>	<input type="checkbox"/>
		4	A-138	Portion Server 4	<input type="checkbox"/>	<input type="checkbox"/>
		4	A-139	Portion Server 5	<input type="checkbox"/>	<input type="checkbox"/>
		4	A-140	Portion Server 6	<input type="checkbox"/>	<input type="checkbox"/>
		48	A-147	Sheet Pans for Camcart	<input type="checkbox"/>	<input type="checkbox"/>
		1	CH-006	Teacher Chair	<input type="checkbox"/>	<input type="checkbox"/>
		1	D-007	Small Private Office Desk 2	<input type="checkbox"/>	<input type="checkbox"/>
		1	E-143	Terrarium Set Up	<input type="checkbox"/>	<input type="checkbox"/>
		3	E-144	Camcarts	<input type="checkbox"/>	<input type="checkbox"/>

**C120**

**Custodial Office**

		1	A-001	Wastebasket	<input type="checkbox"/>	<input type="checkbox"/>
		1	A-061	Recycle Container	<input type="checkbox"/>	<input type="checkbox"/>
		1	CH-006	Teacher Chair	<input type="checkbox"/>	<input type="checkbox"/>
		1	D-007	Small Private Office Desk 2	<input type="checkbox"/>	<input type="checkbox"/>

**C122**

**Cafeteria**

		8	A-060	55 Gallon Brute Trash Can w/ Dolly	<input type="checkbox"/>	<input type="checkbox"/>
		1	CH-013	Task-Stool	<input type="checkbox"/>	<input type="checkbox"/>
		22	T-012	Round Café Table w/ Stools	<input type="checkbox"/>	<input type="checkbox"/>

ROOM NUMBER	ROOM NAME	QTY	Type	Type Comments	ELIGIBILITY	
		6	T-013	Round Café Table- ADA Compliant	<input type="checkbox"/>	<input type="checkbox"/>