

TOWN OF GLASTONBURY

INVITATION TO BID

<u>BID #</u>	<u>ITEM</u>	<u>DATE &amp; TIME REQUIRED</u>
GL-2010-54 <b>REBID</b>	William St. East Bridge Rehabilitation	August 24 <sup>th</sup> 2010 at 11:00 A.M.

The Town of Glastonbury is currently seeking bids for the rehabilitation of the Williams Street East Bridge over Hubbard Brook. Improvements generally include the repair of the existing brick masonry arch culvert, reconstruction of a masonry spandrel wall and parapet wall, installation of metal beam guiderail, and the replacement of a water main over the bridge.

Prevailing Wages: The contractor must comply with Section 31-53 of the Connecticut General Statutes as amended, including annual adjustments in prevailing wages.

Bid Forms and plans may be obtained from the Town's website at [www.glastonbury-ct.gov](http://www.glastonbury-ct.gov) or from the Office of the Purchasing Agent, Town Hall, 2155 Main Street, Glastonbury, Connecticut 06033 (second level).

The Town reserves the right to waive informalities or reject any part of, or the entire bid, when said action is deemed to be in the best interests of the Town. All Sealed Bids must be submitted to the Office of the Purchasing Agent no later than the time and date indicated. All bids will be publicly opened and read.

Mary F. Visone  
Purchasing Agent

**WILLIAMS STREET EAST BRIDGE REHABILITATION  
INVITATION TO BID**

**BID #GL-2010-54 REBID**

TABLE OF CONTENTS

SECTION

Invitation to Bid	IB
Table of Contents	IB
Information for Bidders	IB
General Construction Specifications	GCS
Special Conditions	SC
Detailed Construction Specifications	DCS
Bid Proposal	BP
Attachment A – Prevailing Wage Rate Documentation	
Attachment B – CNG Gas Main Protection Specifications	
Attachment C – Construction Plans	

**WILLIAMS STREET EAST BRIDGE REHABILITATION  
INVITATION TO BID**

**BID #GL-2010-54 REBID**

1. Sealed bids **(one original and one copy)** on the attached Bid Forms will be received at the Office of the Purchasing Agent, Town Hall, 2155 Main Street, Glastonbury, Connecticut 06033 (second level). At the designated time of opening, they will be publicly opened, read, recorded and placed on file.
2. Whenever it is deemed to be in the best interest of the Town, the Town Manager, Purchasing Agent or designated representative shall waive informalities in any and all bids. The right is reserved to reject any bid, or any part of any bid, when such action is deemed to be in the best interest of the Town of Glastonbury.
3. The award will be on the basis of bid total cost unless otherwise specified. The bid total cost shall be arrived at by the mathematical calculation of the unit price multiplied times the quantity specified for each line item, and the total sum of all line items in the bid. In the event that the Town finds computational errors in a respondent's bid proposal, the bid total cost shall be recalculated by the Town based on the unit prices contained in the bid proposal.
4. Bids will be carefully evaluated as to conformance with stated specifications.
5. The envelope enclosing your bid should be clearly marked by bid number, time of bid opening, and date.
6. Specifications must be submitted complete in every detail and, when requested, samples shall be provided. If a bid involves any exception from stated specifications, they must be clearly noted as exceptions, underlined, and attached to the bid.
7. The Bid Documents contain the provisions required for the requested item. Information obtained from an officer, agent, or employee of the Town or any other person shall not affect the risks or obligations assumed by the Bidder or relieve him/her from fulfilling any of the conditions of the bid.
8. Each Bidder is held responsible for the examination and/or to have acquainted themselves with any conditions at the job site which would affect their work before submitting a bid. Failure to meet this criteria shall not relieve the Bidder of the responsibility of completing the bid without extra cost to the Town of Glastonbury.
9. Any bid may be withdrawn prior to the above-scheduled time for the opening of bids or authorized postponement thereof. Any bid received after the time and date specified shall not be considered. No Bidder may withdraw a bid within sixty (60) days after the actual date of the opening thereof. Should there be reasons why a bid cannot be awarded within the specified period, the time may be extended by mutual agreement between the Town and the Bidder.
10. Each bid must be accompanied by a bid bond payable to the Town for ten percent (10%) of the total amount of the bid. The bid bond of the successful Bidder will be retained until the payment bond and performance bond have been executed and approved, after which it will be returned. A certified check may be used in lieu of a bid bond. The Town of Glastonbury will not be liable for the accrual of any interest on any certified check submitted. Cashier's checks will not be accepted.
11. A 100% Performance and Payment bond are required of the successful bidder. This bond shall cover all aspects of the specification and shall be delivered to the Purchasing Agent prior to the issuance of a purchase order. The Performance and Payment Bond will be returned upon the delivery and acceptance of the bid items.
12. The Bidder agrees and warrants that in the submission of this sealed Bid, they will not discriminate or permit discrimination against any person or group of persons on the grounds of

race, color, religion, national origin, sex, or physical disability including, but not limited to blindness, unless it is shown by such Bidder that such disability prevents performance of that which must be done to successfully fulfill the terms of this sealed Bid or in any manner which is prohibited by the laws of the United States or the State of Connecticut: and further agrees to provide the Human Relations Commission with such information requested by the Commission concerning the employment practices and procedures of the Bidder. An Affirmative Action Statement will be required by the successful Bidder.

13. Bidder agrees to comply with all of the latest Federal and State Safety Standards and Regulations and certifies that all work required in this bid will conform to and comply with said standards and regulations. Bidder further agrees to indemnify and hold harmless the Town for all damages assessed against the Town as a result of Bidder's failure to comply with said standards and/or regulations.
14. All correspondence regarding any purchase made by the Town of Glastonbury shall reference the Town's purchase order number. Each shipping container shall clearly indicate both Town purchase order number and item number.
15. Bidder is required to review the Town of Glastonbury Code of Ethics adopted July 8, 2003 and effective August 1, 2003. Bidder shall acknowledge that they have reviewed the document in the area provided on the bid/proposal response page (BP). The selected Bidder will also be required to complete and sign an Acknowledgement Form prior to award. The Code of Ethics and the Consultant Acknowledgement Form can be accessed at the Town of Glastonbury website at [www.glastonbury-ct.gov](http://www.glastonbury-ct.gov). Upon entering the website click on **General Information**, then **Bids and Quotes** which will bring you to the links for the **Code of Ethics** and the **Consultant Acknowledgement Form**. If the Bidder does not have access to the internet, a copy of these documents can be obtained through the Purchasing Department at the address listed within this bid/proposal.
16. **Non-Resident Contractors:**

The Town is required to report names of non-resident (out-of-State) contractors to the State of Connecticut, Department of Revenue Services (DRS) to ensure that Employment Taxes and other applicable taxes are being paid by Contractors. **Upon award, all non-resident contractors must furnish a five percent (5%) sales tax guarantee bond (State Form AU-766) or a cash bond for five percent (5%) of the total contract price (State Form AU-72) to DRS even though this project is exempt from most sales and use taxes.**

See State Notice to Non-Resident Contractors SN 2005 (12). If the above bond is not provided, the Town is required to withhold five percent (5%) from the contractor's payments and forward it to the State DRS.

The contractor must promptly furnish to the Town a copy of the **Certificate of Compliance** issued by the State DRS.
17. Bidder shall include on a sheet(s) attached to its proposal a complete disclosure of all past and pending mediation, arbitration and litigation cases that the bidder or its principals (regardless of their place of employment) have been involved in for the most recent five years. Please include a statement of the issues in dispute and their resolution. Acceptability of Bidder based upon this disclosure shall lie solely with the Town.
18. Bidder or its principals, regardless of their place of employment, shall not have been convicted of, nor entered any plea of guilty, or nolo contendere, or otherwise have been found civilly liable or criminally responsible for any criminal offense or civil action. Bidder shall not be in violation of

any State or local ethics standards or other offenses arising out of the submission of bids or proposals, or performance of work on public works projects or contracts.

19. It is the responsibility of the bidder to check the Town's website before submitting bid for addendums posted prior to bid opening.

20. **Prevailing Wage Rates:**

Wage Rate Determination for this Project from the State of Connecticut is included in the bid documents. Certified payrolls for site labor shall be filled out weekly and submitted monthly to the Town on the correct State form (See Project Manual). The Town reserves the right to, without prior notice, audit payroll checks given to works on site in order to ascertain that wages and fringe benefits are being paid as required by the State of Connecticut. Contractor to comply with Connecticut General Statutes Section 31-53, as amended. Please make special note of the State requirement to adjust wage and fringe benefit rates on each July 1st following the original published rates. These revised rates are available via the internet. See State material attached.

NOTE that bidder is to include in its bid proposal all costs required by such annual increases in the PREVAILING RATES. No Escalation Clauses are to be included in the bidder's proposal and no Escalation Clauses will be in the Contract Agreement. Bidder is to anticipate any future increases and include these costs in its quotation.

Contractor's invoices will not be paid if certified payrolls are incomplete, incorrect or not received in a timely manner.

All Apprentices must be registered with the State of Connecticut and their number shall not exceed the number allowed by law. Otherwise, all workers must be paid at least the Journeyman rate listed including benefits.

**OSHA SAFETY AND HEALTH CERTIFICATION:**

Effective July 1, 2009: Any Mechanic, Laborer, or Worker, who performs work in a classification listed on the prevailing wage rate schedule on any public works project covered under C.G.S. Section 31-53, both on site and on or in the public building, must have completed a federal OSHA Safety and Health course within the last 5 years.

21. **Qualifications Statements and References:**

Each bid shall also include a description of three (3) projects completed by the bidder with references to demonstrate successful experience with similar projects.

**IMPORTANT: Failure to comply with general rules may result in disqualification of the Bidder.**

**NOTE:** Any technical questions regarding this bid shall be made **in writing** (email acceptable) and directed to Daniel A. Pennington P.E., Town Engineer/Manager of Physical Services, 2155 Main Street, PO Box 6523, Glastonbury, CT 06033; [daniel.pennington@glastonbury-ct.gov](mailto:daniel.pennington@glastonbury-ct.gov). Fax (860) 652-7734 between the hours of 8:00 a.m. – 4:30 p.m. For administrative questions concerning this bid/proposal, please contact Mary F. Visone, Purchasing Agent, at (860) 652-7588. All questions, answers, and/or addenda, as applicable will be posted on the Town's website at [www.glastonbury-ct.gov](http://www.glastonbury-ct.gov). (Upon entering the website click on Bids & RFP's). The request must be received at least five (5) business days prior to the advertised response deadline. **It is the respondent's responsibility to check the website for addenda prior to submission of any bid/proposal.**

**01.00 WORKMANSHIP, MATERIALS AND EMPLOYEES**

01.01 Wherever in this contract the word "Engineer" is used, it shall be understood as referring to the Town Engineer/Manager of Physical Services of the Town of Glastonbury acting personally or through any assistants duly authorized.

01.02 The entire work described herein shall be completed in accordance with the plans and specifications to the full intent and meaning of the same. Unless otherwise specified, all materials incorporated in the permanent work shall be new, and both workmanship and material shall be of good quality. The Contractor shall, if required, furnish satisfactory evidence as to the kind and quality of materials.

01.03 The wording "furnish", "install", "construct", "furnish and install", or any similar terms, unless specifically noted to the contrary, shall include all labor, materials, water, tools, equipment, light, power, transportation, and any other services required for the completion of the work.

01.04 The Contractor shall at all times enforce strict discipline and good order among his employees, and shall seek to avoid employing on the work any unfit person or anyone not skilled in the work assigned to him.

**02.00 SUPERINTENDENT**

02.01 The Contractor shall keep on the work during its progress, in the absence of the Contractor, a competent Superintendent. The Superintendent shall be acceptable to the Engineer and shall fully represent the Contractor. All directions given to the Superintendent shall be binding as if given to the Contractor.

**03.00 PRECONSTRUCTION MEETING**

03.01 A Preconstruction Meeting will be held with the Engineer, Contractor, and any private utility company prior to commencing any work. The Engineer shall arrange the meeting based on a mutually convenient time.

**04.00 PERMITS**

04.01 Other than local permits, all permits, licenses, and fees required for the performance of the Contract work shall be secured and paid for by the Contractor.

**05.00 PROPERTY ACCESS**

05.01 The Contractor shall take all proper precautions to protect from injury or unnecessary interference, and provide proper means of access to abutting property where the existing access is cut off by the Contractor.

05.02 The Contractor shall take all proper precautions to protect persons from injury or unnecessary inconvenience and leave an unobstructed way along the public and private places for travelers, vehicles, and access to hydrants.

05.03 The Contractor shall make arrangements with the adjacent property owners for such trespass as he may reasonably anticipate in the performance of the work. All such arrangements shall be reported, in writing, to the Engineer.

**06.00 PROTECTION OF THE PUBLIC AND OF WORK AND PROPERTY**

06.01 The Contractor shall continuously maintain adequate protection of all work from damage, and shall take all reasonable precautions to protect the Town from injury or loss arising in connection with the Contract.

06.02 The Contractor shall adequately protect adjacent private and public property as provided by law and the Contract Documents.

06.03 The Contractor shall make good any damage, injury, or loss of his work and to the property of the Town resulting from lack of reasonable protective precautions.

**07.00 EXISTING IMPROVEMENTS**

07.01 The Contractor shall conduct his work so as to minimize damage to existing improvements. Except where specifically stated otherwise in the specifications, drawings, or as directed by the Engineer, it will be the responsibility of the Contractor to restore to their original condition, as near as practical, all improvements on public or private property. This shall include:

- a. Property within and adjacent to the side of installation such as shrubs, walks, driveways, fences, etc.
- b. Utility mains, ducts, poles, and services. The Contractor is hereby notified that utilities, if/where shown on the plans, are at approximate locations. These locations are subject to possible errors in the source of information and errors in transcription. The Contractor shall make certain of the exact location of all mains, ducts, poles, and services prior to excavation.

**08.00 SEPARATE CONTRACTS**

08.01 The Engineer reserves the right to let other contracts in connection with this work. The Contractor shall afford other contractors reasonable opportunity for the introduction and storage of their materials and the execution of their work, and shall properly connect and coordinate his work with theirs. Wherever work being done by the Town of Glastonbury forces or by other contractors is contiguous to work covered by this Contract, the respective rights of the various interests involved shall be established by the Engineer to secure the completion of the various portions of the work.

**09.00 INSPECTION OF WORK**

09.01 The Town shall provide sufficient personnel for the inspection of the work.

09.02 The Engineer shall at all times have access to the work whenever it is in preparation or progress, and the Contractor shall provide proper facilities for such access and for inspection.

09.03 If the specifications or the Engineer's instructions require any work to be specially tested or approved, the Contractor shall give the Engineer timely notice of its readiness for inspection and, if the inspection is by another authority other than the Engineer, of the date fixed for such inspection. Inspections by the Engineer shall be made promptly. If any work should be covered up without approval or consent of the Engineer, it must, if required by the Engineer, be uncovered for examination and properly restored at the Contractor's expense.

09.04 Reinspection of any work may be ordered by the Engineer. If such work is found to be in accordance with the Contract Documents, the Town shall pay the cost of reinspection and replacement. If such work is not in accordance with the Contract Documents, the Contractor shall pay such cost.

**10.00 RIGHT TO INCREASE OR DECREASE WORK**

10.01 The Town shall have the right to increase or decrease the amount of work herein specified as may be required.

**11.00 RIGHT OF ENGINEER TO STOP WORK FOR WEATHER CONDITIONS**

11.01 Should the work, in the opinion of the Engineer, be in danger by reason of inclemency of weather, or could not be finished in time to prevent such danger, the Contractor shall cease operations upon order of the Engineer, and shall not resume them until ordered to do so by the Engineer when the weather conditions are favorable. The Contractor shall, upon such orders, discontinue work, remove all materials or appliances for or in use upon the work, and place the streets in proper condition for use by the public during the time the work is suspended as herein provided, without cost to the Town.

**12.00 CONTRACTOR TO BE RESPONSIBLE FOR IMPERFECT WORK OR MATERIALS**

12.01 Any faithful work or imperfect material that may be discovered before the acceptance and the payment of the work shall be corrected upon the order of the Engineer. The acceptance and payment of the work does not in any manner relieve the Contractor of his obligation to construct work in the proper manner and the use of materials herein specified.

**13.00 TOWN MAY NOTIFY CONTRACTOR IF WORK IS NOT CARRIED ON SATISFACTORILY**

13.01 If, in the opinion of the Engineer, the Contractor is not proceeding with the work at a sufficient rate of progress so as to finish in the time specified, or has abandoned said work, or is not complying with the terms and stipulations or the Contract and specifications, the Engineer may serve notice on the Contractor to adopt such methods as will ensure the completion of the work in the time specified.

13.02 If, within five days after the Engineer has notified the Contractor that his work is not being carried on satisfactorily as before mentioned, the Engineer shall have the right to annul the Contract and manage the work under the direction of the Engineer, or re-let, for the very best interest of the Town as a new contract, the work under said new Contract shall be considered the responsibility of the defaulting Contractor.



13.03 Additional costs incurred over and above the original Contract shall be borne by the Performance Bond.

**14.00 DEDUCTIONS FOR UNCORRECTED WORK**

14.01 If the Engineer deems it inexpedient to correct work that has been damaged or that was not done in accordance with the Contract, an equitable deduction from the Contract price shall be made therefor.

14.02 The Contractor shall promptly remove from the premises all materials condemned by the Engineer as failing to meet Contract requirements, whether incorporated in the work or not, and the Contractor shall promptly replace and re-execute his own work in accordance with the Contract and without expense to the Town, and shall bear the expense of making good all work by other contractors destroyed or damaged by such removal or replacement.

14.03 If the Contractor does not remove such condemned work and materials as promptly as possible after written notice, the Engineer may remove them and store the materials at the expense of the Contractor.

**15.00 CLEANING UP**

15.01 The Contractor must remove all debris of every description as the work progresses and leave the surroundings in a neat and orderly condition to the satisfaction of the Engineer.

15.02 Upon completion, and before acceptance and final payment, the Contractor shall remove from the site all equipment, forms, surplus material, rubbish and miscellaneous debris and leave the site in a neat and presentable condition.

**16.00 ROYALTIES AND PATENTS**

16.01 The Contractor shall pay all royalties and license fees. He shall defend all suits or claims for infringement of any patent rights and shall save the Town of Glastonbury harmless from loss on account thereof, except that the Town of Glastonbury shall be responsible for all such loss when a particular manufacturer, product, or process is specified by the Town of Glastonbury.

**01.00 NOTICE TO CONTRACTOR**

01.01 Intent of Contract: The intent of the Contract is to prescribe a complete work or improvement that the Contractor undertakes to do, in full compliance with the specifications, plans, special provisions, proposal, and Contract. The Contractor shall perform all work in close conformity with the lines, grades, typical cross-sections, dimensions, and other data shown on the plans or as modified by written orders, including the furnishing of all materials, implements, machinery, equipment, tools, supplies, transportation, labor, and all other things necessary to the satisfactory prosecution and completion of the project.

01.02 The Contractor is hereby alerted to the fact that the State of Connecticut Department of Transportation Standard Specifications for Roads, Bridges and Incidental Construction, Form 816 (Form 816") and supplements thereto are to be considered part of the Contract Documents. The Form 816 shall not be provided by the Town and any cost associated therewith shall be the responsibility of the Contractor. In case of any discrepancy between the Contract Drawings or Specifications and the Form 816, the matter shall immediately be submitted to the Engineer. The Engineer shall have sole authority in resolving any discrepancies.

01.03 Much time and effort has gone into this project in an effort to minimize impact on trees and adjacent properties. Extreme care shall be taken by the Contractor to honor commitments made by the Town. Prior to doing any work, the Contractor shall meet with the Engineer to become familiar with the conditions encountered and commitments made.

**02.00 COMMUNICATIONS**

02.01 All notices, demands, requests, instructions, approvals, proposals, and claims must be in writing.

02.02 Any notice to, or demand upon, the Contractor shall be sufficiently given if delivered at the office of the Contractor stated on the signature page of the Agreement (or at such other office as the Contractor may, from time to time, designate) in a sealed, postage-prepaid envelope or delivered with charges prepaid to any telegraph company for transmission, in each case addressed to such office.

02.03 All papers required to be delivered to the Town shall, unless otherwise specified in writing to the Contractor, be delivered to the Town Engineer/Manager of Physical Services, 2155 Main Street, Glastonbury, CT 06033, and any notice to, or demand upon, the Town shall be delivered at the above address in a sealed, postage-prepaid envelope or delivered with charges prepaid to any telegraph company for transmission, in each case addressed to such office or to such other representatives of the Town, or to such other address as the Town may subsequently specify in writing to the Contractor for such purpose.

02.04 Any such notice shall be deemed to have been given as of the time of actual delivery or, in case of mailing, when the same should have been received in due course of post or, in the case of telegrams, at the time of actual receipt, as the case may be.

**03.00 PARTIAL USE OF IMPROVEMENTS**

03.01 The Town may, at its election, give notice to the Contractor and place in use those sections of the work that have been completed, inspected and can be accepted as complying with the Contractor Documents and if, in its opinion, each such section is reasonably safe and fit for the use and accommodation for which it was intended, provided:

- a. The use of such sections of the work shall not materially impede the completion of the remainder of the work by the Contractor.
- b. The Contractor shall not be responsible for any damages or maintenance costs due directly to the use of such sections.
- c. The use of such sections shall in no way relieve the Contractor of his liability due to having used defective materials or to poor workmanship.
- d. The period of guarantee shall not begin until the date of the final acceptance of all work required under this Contract.

**04.00 INSURANCE**

04.01 The Contractor shall, at its own expense and cost, obtain and keep in force during the entire duration of the Project or Work the following insurance coverage covering the Contractor and all of its agents, employees and sub-contractors and other providers of services and shall name **both the Town and the Metropolitan District Commission, their employees and agents as an Additional Insured** on a primary and non-contributory basis to the Bidders Commercial General Liability and Automobile Liability policies. **These requirements shall be clearly stated in the remarks section on the Contractors Certificate of Insurance.** Insurance shall be written with Carriers approved in the State of Connecticut and with a minimum Best's Rating of A-. In addition, all Carriers are subject to approval by the Town. Minimum Limits and requirements are stated below:

- a. Worker's Compensation Insurance:
  - Statutory Coverage
  - Employer's Liability
  - \$100,000 each accident/\$500,000 disease-policy limit/\$100,000 disease each employee
- b. Commercial General Liability:
  - Including Premises and Operations, Products and Completed Operations, Personal and Advertising Injury, Contractual Liability and Independent Contractors
  - Limits of Liability for Bodily Injury and Property Damage  
Each Occurrence: \$1,000,000  
Aggregate: \$2,000,000  
(The Aggregate Limit shall apply separately to each job.)

- A Waiver of Subrogation shall be provided.

c. Automobile Insurance:

- Including all owned, hired, borrowed, and non-owned vehicles
- Limit of Liability for Bodily Injury and Property Damage  
Per Accident: \$1,000,000

d. Protective Liability (Owners and Contractors Protective Liability, OCP)

For and in the name of the Town of Glastonbury and the Metropolitan District Commission with per project minimum limits of liability as follows:  
Each Occurrence: \$1,000,000  
Aggregate: \$1,000,000

04.02 The Bidder shall direct its Insurer to provide a Certificate of Insurance to the Town before any work is performed. The Certificate shall specify that the Town shall receive 30 days advance written notice of cancellation or non-renewal. The Certificate shall evidence all required coverage including the Additional Insured and Waiver of Subrogation. The Bidder shall provide the Town copies of any such insurance policies upon request.

04.03 INDEMNIFICATION: To the fullest extent permitted by law, the Contractor shall indemnify and hold harmless the Town, the Board of Education, and the Metropolitan District, and their consultants, agents, and employees from and against all claims, damages, losses and expenses, direct, indirect or consequential (including but not limited to fees and charges of engineers, attorneys and other professionals and court and arbitration costs) arising out of or resulting from the performance of the Contractor's work, provided that such claim, damage, loss or expense is caused in whole or in part by any negligent act or omission by the Contractor, or breach of its obligations herein or by any person or organization directly or indirectly employed or engaged by the Contractor to perform or furnish either of the services, or anyone for whose acts the Contractor may be liable, regardless of whether or not it is caused in part by a party indemnified hereunder.

**05.00 WORK BY OTHERS**

05.01 Private utilities, contractors, developers or other parties may be expected to be working within the Contract area during this Contract. It shall be the responsibility of the Contractor to coordinate his work with the work being done by others in order that the construction shall proceed in an efficient and logical manner. The Contractor shall have no claim or claims whatever against the Town, the Engineer, or other parties due to delays or other reasons caused by the work by others or his failure to coordinate such work.

**06.00 CONTRACTOR'S WORK AND STORAGE AREA**

06.01 The Contractor shall contact the Town to determine if any specific locations will be designated, or gain its approval prior to using any area for storage of equipment, materials and trailers during the period of this Contract. The Contractor shall confine his work/storage area to the limits as designated or approved and shall be responsible for the security of the work/storage area. Upon completion of the Contract, the Contractor shall remove all equipment and materials, except as otherwise specified, and restore the site to its original condition as approved by the Engineer and at not cost to the Town.

**07.00 DISPOSAL AREA**

07.01 The Tryon Street Bulky Waste Facility will be available to the Contractor, at no charge, for disposal of materials that are accepted at that facility. Acceptable materials include brush, stumps, demolition materials, and excess excavated earth materials. Unacceptable materials are hazardous wastes such as pesticides, oil based paints and thinners, or other wastes as designated by the State Department of Environmental Protection. Demolition material cannot contain asbestos or other hazardous materials. The Contractor is required to obtain a disposal area for all other unsuitable or surplus materials at no cost to the Town.

**08.00 DUST CONTROL**

08.01 During the progress of the work, the Contractor shall conduct his operations and maintain the area of his activities so as to minimize the creation and dispersion of dust. If the Engineer decides that it is necessary to use water or calcium chloride for more effective dust control, the Contractor shall furnish and spread the material, as directed, without additional compensation.

**09.00 MAINTENANCE / GUARANTEE PERIOD**

09.01 The Contractor shall be held responsible to the Town for maintenance for a minimum of one-year following completion of all work under this Contract with respect to defects, settlements, etc.

**10.00 PROTECTION OF EXISTING UTILITIES**

10.01 Before starting any excavation, the Contractor shall submit to the Engineer plans or details showing the proposed method the Contractor will use to support and protect all existing utilities during construction. The furnishing of such plans and details shall not serve to relieve the Contractor of any responsibility for the proper conduct of the work.

10.02 There will be no extra payment for submitting plans or details for supporting and protecting all existing utilities during construction.

**11.00 TIME FOR COMPLETION/NOTICE TO PROCEED**

11.01 Within ten (10) calendar days after the date of the Notice of Award, the Contractor must provide the appropriate bond and insurance certificates to the Town Purchasing Agent and must be issued a Purchase Order for the Project prior to initiating any work.

11.02 The work under this Contract shall commence within twenty-one (21) calendar days of the date listed on the Notice to Proceed / Purchase Order. After the work has begun, it shall continue in an orderly fashion such that all contract work is completed within forty-five (45) calendar days from the date of commencement.

**12.00 LIQUIDATED DAMAGES**

12.01 As actual damages for any delay in completion of the work that the Contractor is required to perform under this Contract are impossible to determine, the Contractor and the Sureties shall be liable for and shall pay to the Town the sum of \$100.00 as fixed, agreed and liquidated damages for each calendar day of delay from the above-stipulated completion, or completion as modified in writing by both parties, until such work is satisfactorily completed and accepted.

**13.00 SCHEDULE OF DRAWINGS**

13.01 The Contractor is hereby alerted that the plan set entitled "Plan for the Rehabilitation of Williams Street East Bridge, State Bridge No. 053015 in the Town of Glastonbury Connecticut", including eight (8) plan sheets is to be considered part of these specifications.

**14.00 CHANGES IN THE WORK**

14.01 The Town reserves the right to perform portions of the work in connection with these plans and specifications. The reduction in the work to be performed by the Contractor shall be made without invalidating the Contract. Whenever work is done by the Town contiguous to other work covered by this Contract, the Contractor shall provide reasonable opportunity for the execution of the work and shall properly coordinate his work with that of the Town.

**15.00 LAYOUT OF WORK**

15.01 The Town shall provide stake-out of the work in accordance with the plans or as directed by the Engineer. The Contractor shall protect all stakes from damage or destruction and shall be responsible to assure that the grade stakes have not been altered prior to actual construction. The Town shall replace grade stakes that have been removed, at no cost to the Contractor, if their removal was caused by reasons beyond reasonable care and protection by the Contractor. If it is determined by the Engineer that the Contractor did not provide reasonable protection, the cost of restaking will be deducted from any amounts due the Contractor in the performance of the work.

**16.00 REMOVAL AND STORAGE OF MATERIALS AND STRUCTURES FOUND ON THE WORK**

16.01 All salvageable materials, including topsoil, gravel, fill materials, etc. and structures, including drainage pipes, catch basins and manhole frames and covers, guide railing, etc. that are not to remain in place or that are not designated for use in the work, shall be carefully removed by the Contractor and stored at such places as directed by the Engineer. All salvageable materials removed and stored shall remain the property of the Town. The Engineer shall determine the materials or structures to be salvaged.

**17.00 PROSECUTION AND PROGRESS**

17.01 The Contractor shall give the Engineer a seven-day advance written notice of construction activities that will alter traffic patterns that result in lane shifts, detours, temporary closures of lane(s), permanent closure of lane(s), or lane reductions. This advance notification will allow the Town to publish news releases and/or provide public radio announcements to inform the public of revised traffic patterns or possible traffic delays. Failure of the Contractor to provide such timely notice shall be considered a breach of Contract and will subject the Contractor to stop work orders until such time as the seven-day notice has been satisfied.

**18.00 EXTRA AND COST PLUS WORK**

18.01 Extra and cost plus work shall be governed by Article 1.04.05 and Article 1.09.04 of the Form 816.

**19.00 COMPLIANCE WITH ENVIRONMENTAL PERMITS**

19.01 A Town of Glastonbury Inland Wetland Permit and Section 4.11 Flood Zone Permit were required for this project and these approvals are included on the construction plans. By submitting a bid, the Contractor confirms that they have read and are familiar with all of the required conditions of this permit and will conduct the work in a manner consistent with these requirements.

**20.00 SUBMITTALS AND MATERIALS TESTING**

20.01 The Contractor shall provide source and supply information, sieve analysis, and material samples for pervious structure backfill and all other granular materials to the Town for review and approval. The Town shall retain a lab for testing of these materials as required and shall perform in place compaction testing at no expense to the Contractor.

20.02 Shop drawings / catalog cuts shall be provided by the Contractor for all pre-cast concrete structures, pipes and fittings, erosion control products, geotextile fabric, seed mixes, and other items to be supplied for review and approval by the Engineer as described in the specifications and the Form 816.

20.03 Mix designs for all bituminous and portland cement concrete materials shall be provided by the Contractor to the Engineer for review and approval.

20.04 Certified Materials Test Reports and Materials Certificates shall be provided for all products and materials to be provided under this contract as described in these specifications and the Form 816.

20.05 Plans for protection of the existing gas main shall be prepared by the Contractor and submitted to the Engineer and CNG for review as described in Section 103.

20.06 Shop drawings for the proposed debris shield / work platform shall be submitted to the Engineer for review as described in Section 134.

**TABLE OF CONTENTS**

<b>SECTION</b>	<b>DESCRIPTION</b>	<b>PAGE</b>
102.0	STRUCTURE EXCAVATION.....	2
103.0	PROTECTION AND SUPPORT OF EXISTING UNDERGROUND CNG FACILITIES .....	3
114.0	PERVIOUS STRUCTURE BACKFILL .....	5
120.0	RESETTING STONE MASONRY.....	7
125.0	CLASS "A" CONCRETE .....	8
130.0	DEFORMED STEEL BARS – EPOXY COATED.....	9
132.0	DRILLING AND GROUTING REINFORCING BARS .....	10
134.0	DEBRIS SHIELD.....	11
135.0	STRUCTURAL STEEL .....	12
140.0	CEMENT RUBBLE MASONRY .....	13
150.0	REMOVE AND REPLACE BRICK MASONRY.....	14
160.0	REPOINTED MASONRY .....	16
210.0	UNDERDRAIN .....	17
215.0	GEOTEXTILE SUBSURFACE DRAINAGE – (CLASS A) .....	18
220.0	IMPERVIOUS POLYETHYLENE GEOMEMBRANE LINER .....	19
230.0	METAL BEAM RAIL TYPE RB-350 .....	20
235.0	METAL BEAM RAIL ANCHORAGES .....	21
240.0	R-B 350 BRIDGE ATTACHMENT – VERTICAL SHAPED PARAPET.....	22
290.0	REMOVAL OF EXISTING MASONRY .....	23
650.0	DUCTILE IRON PIPE (WATER MAIN) .....	24
652.0	PIPE INSULATION (WATER MAIN).....	41



**102.0 STRUCTURE EXCAVATION**

102.1 General: This item shall conform to Section 2.03 STRUCTURE EXCAVATION of the Form 816, with the following section(s) replaced.

102.2 Basis of Payment (Section 2.03.05): Payment for this work will be made at the Contract unit price per cubic yard for: Structure Excavation—Earth (complete), which price shall include all materials, tools, and equipment; all work related to cofferdams, including their design, construction, dewatering, repair, removal of obstructions, and any required reconstruction; all labor necessary to complete the excavation in conformity with the requirements of the plans or as ordered by the Engineer; the preparation of foundations as described under Article 2.03.03 of the Form 816; all necessary filling, except as otherwise provided in the Contract; and the removal of all surplus or unsuitable material resulting from the excavations.

**103.0 PROTECTION AND SUPPORT OF EXISTING UNDERGROUND CNG FACILITIES**

103.1 Description: Work under this item shall consist of designing, furnishing, and placing temporary supports and temporary protection shields which will be necessary to protect the existing underground gas main during construction. The Contractor is herein made aware that the proposed work will require excavations that will expose the adjacent active gas mains owned by Connecticut Natural Gas Corporation. The work shall be performed in accordance with these specifications.

All work shall be in conformance with "CNG General Provisions for Contractors When Excavating Over Cast Iron Gas Mains", and Connecticut Natural Gas Corporation Department Procedure (480.01) "Protection / Replacement of Exposed Gas Facilities". A copy of these documents is included as Attachment B to the contract documents.

The work pertaining to the temporary support primarily involves the support and prevention of damages which are possible during the excavation and construction for the rehabilitation of the brick masonry arch culvert as included under this contract.

The Contractor is advised that no service interruption to the gas facility resulting from Contractor operations will be allowed, except as otherwise provided for in the Special Provision "Prosecution and Progress." Extreme caution shall be exercised during all stages of construction in order to preserve the existing utilities. A Town representative shall be present at the installation of the temporary supports and protection shields.

The Contractor shall notify the Engineer prior to the start of his work and shall be responsible for all coordination with the Town and the utility. The Contractor shall allow the Engineer complete access to the work.

The Contractor is cautioned that it is his responsibility to verify locations, conditions and field dimensions of all existing features, as actual conditions may differ from information indicated on the plans or contained elsewhere in these specifications.

103.2 Materials: The materials for this work shall conform to the requirements of the Form 816 and be of satisfactory quality for the purpose intended and shall be approved by the Engineer. The material shall be intended for use in structures and shall be sound and capable of safely carrying the loads anticipated as part of the design of the protection shield.

103.3 Construction Methods: The Contractor shall prepare working drawings and computations showing his proposed method of support and protection for the utility to be supported and protected. Preparation of working drawings and computations shall conform to the requirements of Article 1.05.02 of the Form 816. The support shall safely carry all dead loads and any imposed loadings under all possible construction conditions. The utility protection shields shall safely carry any imposed loadings under all possible construction conditions. Said supports and protections shall be constructed in a manner that will not interfere with the proposed construction.

The design shall be submitted to the utility representatives for review and approval. Following approval, the design shall be submitted to the Engineer for final approval at least two (2) weeks prior to the beginning of construction. No work will be allowed in the vicinity of any utility until the Contractor receives approval of his support method from the utility representative and the Engineer.

The Contractor shall use every effort to protect all utilities from damage of any nature which might result from carelessness or negligence in his operations. He shall be held solely and strictly responsible for any damage resulting from such carelessness and negligence.

A periodic inspection of the temporary utility support and protection shield shall be performed by the Contractor, as directed by the Engineer.

The Contractor shall support and maintain the existing utilities until the proposed foundation construction has been completed to a point where removal of the temporary supports will not cause damage to the protected utility.

When the temporary utility supports and protection shield are no longer required, they shall be removed from the site by the Contractor.

103.4 Method of Measurement: This work, being paid for on a lump sum basis, will not be measured for payment.

103.5 Basis for Payment: The work will be paid for at the contract lump sum price for "Protection and Support of Existing Underground CNG Facilities" which price shall include designing and detailing all supports and protection shields, furnishing, periodic monitoring, installing, removal, disposal, coordinating work with the utility companies, and all materials, equipment, tools and labor incidental thereto.

**114.0 PERVIOUS STRUCTURE BACKFILL**

114.1 General: Pervious structure backfill shall include the furnishing, placing, and compaction of pervious material adjacent to structures. This item shall also consist of furnishing and placing crushed stone or gravel in burlap bags at the inlet ends of weep holes in structures to the dimensions indicated on the plans or as ordered by the Engineer.

114.2 Material: Pervious structure backfill shall conform to the requirements of Article M.02.05.

The materials for bagged stone shall conform to the following requirements:

(a) The crushed stone or gravel shall conform to the grading requirements of Article M.01.01 for No. 3 or No. 4 coarse aggregate or a mixture of both.

(b) The bag shall be of burlap and shall be large enough to contain one cubic foot of loosely packed granular material.

114.3 Construction Methods: Pervious structure backfill shall be placed adjacent to abutments, retaining walls, box culverts, and elsewhere as called for. It shall be placed above a plane extending on a 2 to 1 slope from the upper edge of the footing to the top of the embankment, or as shown on the plans. Where the face of undisturbed material is above or beneath this slope plane, the amount of pervious structure backfill shall be decreased or increased accordingly, if ordered by the Engineer.

In filling behind abutments, retaining walls, box culverts, or other structures, the fill is placed against undisturbed material, or against compacted embankments having a length in a direction at right angles to the abutment wall or culvert not less than twice the height of the structure against which the fill is placed. The slope of the embankment on which the pervious structure backfill is to be placed shall be plowed deeply or cut into steps before and during the placing of pervious structure backfill so both types of material will be thoroughly bonded and compacted.

Each layer of pervious structure backfill shall be spread to a thickness not exceeding 6 inches in depth after compaction and shall be thoroughly compacted as directed by the Engineer by the use of power rollers or other motorized vehicular equipment, by tamping with mechanical rammers or vibrators, or by pneumatic tampers. Any equipment not principally manufactured for compaction purposes and equipment, which is not in proper working order in all respects, shall not be used within the area described above.

Special attention shall be given to compaction in places close to walls where motorized vehicular equipment cannot reach. Within 3 feet of the back face of walls and within a greater distance at angle points of walls, each layer of pervious structure backfill shall be compacted by mechanical rammers, vibrators, or pneumatic tampers.

The dry density of each layer of pervious structure backfill formed from broken or crushed stone, broken or crushed gravel or reclaimed miscellaneous aggregate free of bituminous concrete shall have a dry density after compaction that is no less than 100 percent of the dry density for that material when tested in accordance with AASHTO T180, Method D. If a layer formed from reclaimed miscellaneous aggregate containing bituminous concrete is placed as pervious structure backfill, the wet density of this layer after compaction shall not be less than 100 percent of the wet density of that material when tested in accordance with AASHTO T180, Method D.

In this test, material retained on the ¾ inch sieve shall be replaced with material retained on the number 4 sieve, as noted as an option in the specifications for this test.

Each layer of the pervious structure backfill shall be compacted at optimum moisture content. No Subsequent layer shall be placed until the specified compaction is obtained for the pervious layer.

Where weep holes are installed, bagged stone shall be placed around the inlet end of each weep hole, to prevent movement of the pervious material into the weep hole. Approximately one cubic foot of crushed stone or gravel shall be enclosed in each of the burlap bags. All bags shall then be securely tied at the neck with cord or wire so that the enclosed material is contained loosely. The filled bags shall be stacked at the weep holes to the dimensions shown on the plans or as directed by the Engineer. The bags shall be unbroken at the time pervious material is placed around them, and bags which are broken or burst prior to or during the placing of the pervious material shall be replaced at the expense of the contractor.

114.4 Method of Measurement: Payment lines for pervious structure backfill shall coincide with the limits of the compacted pervious structure backfill as actually placed and ordered by the Engineer. There shall be no direct payment for bagged stone, but the cost thereof shall be considered as included in the cost of the work for "Pervious Structure Backfill".

114.5 Basis of Payment: Pervious structure backfill will be paid for the contract unit price per cubic yard for "Pervious Structure Backfill", complete in place.

**120.0 RESETTING STONE MASONRY**

120.1 General: Work under this item shall consist of removing existing in place stones and relocating displaced and fallen stones in order to reset the stones within cement rubble masonry walls, dry rubble masonry walls, or other stone masonry structures where indicated and to the limits necessary to complete the work, approved by the engineer prior to commencing with the work.

120.2 Materials: Stones shall consist of existing stones removed and prepared for reuse as necessary to complete the work. Cracked, deteriorated, and missing stones shall be replaced as directed by the engineer with stones conforming to Article M.11.02 for rubble masonry stone.

120.3 Construction Methods: Existing stone masonry shall be removed to the limits necessary to complete the work, approved by the engineer prior to removal. Due precaution shall be taken to avoid damage to existing construction to remain, new construction, public utility installations or abutting property. Any damage shall be repaired by the Contractor, as directed by the Engineer, and at no cost to the Town.

Pneumatic hammers or any other method approved by the Engineer may be used to remove the existing masonry. Maximum 15 pound hammers shall be used for general removal of stone. When removing stone, the Contractor shall take necessary precautions to prevent construction materials, equipment and debris from dropping into the areas below the structure and into the stream.

The Contractor shall take necessary precautions to prevent any damage to the portions of the structure to remain. Any damage shall be repaired by the Contractor, as directed by the Engineer, and at no cost to the Town.

All material that is not salvaged for reuse due to damage or deterioration shall be considered debris. All debris shall be legally disposed of, from the site, by the Contractor.

Resetting stone masonry within Cemented Rubble Masonry construction shall conform to Article 6.06.03. Resetting stone masonry with Dry Rubble Masonry construction shall conform to Article 6.07.03.

122.4 Method of Measurement: Stone masonry reset under this item shall be paid for at the Contract lump sum price for "Resetting Stone Masonry" and not measured for payment.

122.5 Basis of Payment: This work will be paid for at the contract lump sum price for "Resetting Stone Masonry" complete in place, including all materials, equipment, tools, labor, and miscellaneous materials and items incidental thereto.

**125.0 CLASS "A" CONCRETE**

125.1 General: This item shall conform to Section 6.01 CONCRETE FOR STRUCTURES, of the Form 816, with the following sections amended or replaced:

125.2 Basis of Payment (Section 6.03.05): Payment for this work will be made as follows:

This material will be paid for at the contract unit price per cubic yard for "Class A Concrete", complete in place, which price shall include all materials, equipment, tools, labor and work incidental thereto, including heating, all admixtures and joint sealer.

No direct payment will be made for the work of testing the concrete in structures, any testing equipment, the instruction of its use, or for the concrete in or curing of the required test cylinders as specified, or for completion dates set in the forms; but, the cost of this work shall be considered as included in the general cost of the work. The work of transporting and testing these cylinders will be done by the Town without expense to the Contractor.

There shall be no direct payment for the cost of forming keys or construction joints, but the cost thereof shall be considered as included in the cost of the concrete items.

Where steel dowels are used, this material will be paid for under the reinforcement item. There shall be no direct payment for forming weep holes through the wall or for the pipe necessary for this purpose, but the cost thereof shall be considered as included in the general cost of the work.

There shall be no direct payment for the work of placing anchor bolts and similar materials.

**130.0 DEFORMED STEEL BARS – EPOXY COATED**

130.1 General: This item shall conform to Section 6.02 REINFORCING STEEL, of the Form 816, with the following section(s) replaced:

130.2 Basis of Payment (Section 6.02.05): Payment for this work will be made as follows:

This work will be paid for at the contract unit price per pound for "Deformed Steel Bars – Epoxy Coated", complete in place and accepted, including shop drawings, furnishing, fabricating and placing reinforcing steel, welding splices and all materials, equipment, tools, labor and work incidental thereto.



**132.0 DRILLING AND GROUTING REINFORCING BARS**

132.1 General: This item shall consist of drilling holes into concrete or stone masonry, cleaning and preparing holes, and installing and grouting into place reinforcing bars as indicated on the plans.

132.2 Materials: Provide materials that comply with the following:

Reinforcing bars shall be epoxy coated and conform to Article M.06.01. Grout shall be non-shrink non-staining grout and conform Article M.03.01.

132.3 Construction Methods: Drill holes into concrete or stone masonry at the location and spacing indicated on the plans. Holes shall be drilled to the diameter recommended by the grout manufacturer for the reinforcing bar size indicated on the plans. Maintain proper vertical and horizontal alignment while drilling holes. The holes shall be drilled to the minimum depths indicated on the plans, cleaned, and prepared prior to placing grout and setting reinforcing steel.

Clean and prepare holes in accordance the grout manufacturer's written instructions. At a minimum, the following procedure shall apply to cleaning and preparing holes prior to installing grout:

- Use compressed air to blow debris, dust, and water from the hole
- Use a stiff bristle brush to clean the hole
- Use compressed air to blow out debris and dust after brush cleaning

For vertical holes, do not leave ungrouted vertical holes overnight and exposed to freezing temperature. For horizontal holes, drill holes at a 10 degree (minimum) down angle from the horizontal plane.

Steel reinforcement shall be accurately placed as shown on the plans. Using an approved grout, mix, apply and cure the grout according to the manufacturer's instructions. Fill the dry, clean holes with grout and insert the reinforcing bar into the freshly grouted hole so that no voids exist between the reinforcing bar and the concrete or stone masonry. Clean any grout overflow and center the reinforcing bar in the hole and secure in place until the grout has sufficiently cured. Reinforcing steel shall be supported in its proper position by use of tie down bars or other approved devices. Such devices shall be sufficiently strong and properly placed at frequent intervals so as to maintain the cover between the reinforcing bars and the surface of the concrete. The reinforcing steel cover shall be no less than that shown on the plans.

132.4 Method of Measurement: No measurement will be made for payment for any clips, wire, separators, shims, wire chairs, mortar blocks, and other material used for supporting the reinforcing bars in the correct position. Drilling and grouting reinforcing bars will be measured for payment by the number of linear feet of reinforcing bars grouted into drilled holes. This measurement will not include that portion of the reinforcing bar located outside of the hole into which it is grouted.

132.5 Basis of Payment: This work will be paid for at the contract unit price per linear foot of "Drilling and Grouting Reinforcing Bars", complete in place, which price shall include all materials, equipment, tools and labor incidental thereto, including the cost of furnishing reinforcing bars and grout.

**134.0 DEBRIS SHIELD**

134.1 General: This item shall consist of configuring, designing, installing, and maintaining a debris shield to prevent objects, equipment, construction materials, and debris from falling into the stream below the work area. This debris shield may also serve as a work platform allowing access to the underside of the bridge.

134.2 Materials: Provide materials that comply with the following:

If scaffolding is used, the scaffolding legs shall be manufactured with pipe having a min. O.D. of 1.625" with a wall thickness of 0.1 inch.

Acceptable lumber and timber Species and Grade: Balsam fir, Douglas fir-larch, Douglas fir-larch (North), eastern hemlock tamarack (North), hem-fir, southern pine, western hemlock, or western hemlock (North); No. 2 or better, NELMA, NLGA, SPIB, WCLIB, or WWPA.

All steel shapes, plates, and tubes, unless otherwise specified, shall conform to ASTM A-36, as amended to date. Steel pipe shall conform to ASTM 53, Grade B.

Anchor bolts shall be removable mechanical anchor bolts as indicated on the plans.

134.3 Construction Methods: Prior to the start of construction the contractor shall, in the field, verify all elevations and dimensions, the overall dimensions required for the debris shield. The contractor is responsible for and shall determine the location and type of supports to be used, the configuration of the debris shield platform, and the manner of installation and removal. The contractor shall configure and design the debris shield to adequately support the loading requirement provided on the plans.

If the contractor will use the debris shield as a work platform, the configuration of debris shield shall include all applicable OSHA compliant railings, ladders, toe boards and appurtenances. If the contractor will use the debris shield as a support platform for materials or equipment that exceeds the loading provided on the plans, the debris shield shall be designed to support the highest anticipated loads located to induce maximum stress effects.

The maximum number and general configuration of supports shall be as indicated on the plans. Any supports founded on the streambed shall be adequately supported by concrete blocks to distribute loads. The configuration and installation of the debris shield shall allow for its timely removal during inclement weather events.

The contractor shall submit for review, the configuration and design of the debris shield, which shall include a list of equipment and materials, if any, that are to be supported by the debris shield during construction which exceed the loads provided on the plans.

134.4 Method of Measurement: Debris Shield installed, adequately maintained for the duration of the work, and completely removed, shall be paid for at the Contract lump sum price for "Debris Shield".

134.5 Basis of Payment: Debris Shield will be paid for at the Contract lump sum price for "Debris Shield", which price shall include all materials, equipment, tools and labor incidental to the installation of the debris shield complete in place, adequately maintained throughout the duration of the work for which its use is required, and completely removed upon completion of the work.

**135.0 STRUCTURAL STEEL**

135.1 General: This item shall conform to Section 6.03 STRUCTURAL STEEL, of the Form 816, with the following section replaced:

135.2 Basis of Payment: The structural steel and metal of the various other types covered by this section, incorporated in the completed and accepted structure, will be paid for at the contract unit price per pound (lb) for "Structural Steel".

Payment shall be for structural steel, complete in place, which price shall include furnishing, fabricating, transporting, erecting, surface preparation, painting, galvanizing and all materials, equipment, tools and labor incidental thereto.

No direct payment will be made for setting anchor bolts and anchorage material, preparing bearing areas, furnishing and placing materials under shoes and setting shoes, but the cost thereof shall be included in the general cost of the work.

Anchorage materials furnished by the Contractor for the superstructure and placed by the Contractor for the substructure will be included as part of the superstructure contract.

**140.0 CEMENT RUBBLE MASONRY**

140.1 General: This item shall conform to Section 6.06 CEMENT RUBBLE MASONRY, of the Form 816, with the following section replaced:

140.2 Basis of Payment: This work will be paid for at the contract unit price per cubic yard for "Cement Rubble Masonry" complete in place which price shall include all materials, equipment, tools and labor incidental thereto.

**150.0 REMOVE AND REPLACE BRICK MASONRY**

150.1 General: This item includes the reconstruction of the existing brick masonry arch to the limit indicated on the plans and shall consist of approved brick and mortar, laid in full mortar beds, constructed in such shapes and at such places as indicated on the plans or where directed, and in accordance with these specifications.

150.2 Materials: The materials for this work shall conform to the requirements of Article M.11.04 for brick masonry, and Article M.11.04 for mortar. Existing brick masonry removed from the existing arch shall not be salvaged for use in reconstruction of the arch. Only new brick complying with Article M.11.04 shall be used.

150.3 Construction Methods: The masonry shall be removed and reconstructed in the location and to the limits shown on the plans, or as ordered by the engineer.

The Contractor shall take necessary precautions to prevent any damage to the portions of the structure to remain. Any damage shall be repaired by the Contractor, as directed by the Engineer, and at no cost to the Town.

All necessary dressing or shaping shall be done before the brick is laid. No dressing or hammering which will loosen the brick will be permitted after it is placed. In general, the brick shall be placed in complete units with tapered mortar joints. The maximum joint width shall be ½ inch. The minimum joint width shall be 1/8 inch.

Brick shall not be laid when the air temperature in the shade, and away from artificial heat, is 40°F or below and falling, except with the approval of the Engineer and subject to such conditions as the Engineer may impose.

Any repairs to the abutments indicated on the plans shall be made prior to performing this work. Any deficiencies in the abutments not apparent until removal of the existing masonry shall be brought to the attention of the Engineer immediately. The top of the abutments where the reconstructed masonry is to bear shall be cleaned of all dirt, debris, and deleterious materials prior to placing any masonry.

Brick shall be new, clean and set such that all mortar joints are completely full. The configuration and the thickness of the reconstructed brick masonry arch shall match the existing.

Whenever possible the face joints shall be properly pointed before the mortar becomes set. Joints which cannot be so pointed shall be prepared for pointing by raking them out to a depth of about 2 inches before the mortar has set. The face surfaces of bricks shall not be smeared with the mortar forced out of the joints or that used in pointing.

In case any brick is moved or the joint broken, the brick shall be taken up, the mortar thoroughly cleaned from bed and joints, and the brick reset in fresh mortar.

Pointing shall not be done in freezing weather or when the bricks contain frost. Joints not pointed at the time the brick is laid shall be thoroughly wet with water and filled with mortar. The mortar shall be well driven into the joints and finished with an approved pointing tool. The masonry shall be kept moist while pointing is being done; and in hot or dry weather, the pointed masonry shall be protected from the sun and kept moist for a period of at least three days after completion.

After the pointing is completed and the mortar set, the brick shall be thoroughly cleaned and left in a neat and workman-like condition. The work shall be protected so that it is not exposed to the action of running water until such time as the mortar has attained a strength sufficient, in the opinion of the Engineer, to prevent injury to the work from such exposure.

150.4 Method of Measurement: Removal of existing bridge masonry within the arch barrel and reconstruction of this removed portion shall be paid for at the Contract lump sum price for "Remove and Replace Brick Masonry".

150.5 Basis of Payment: Removal and reconstruction of brick masonry will be paid for at the Contract lump sum price for "Remove and Replace Brick Masonry", which price shall include all brick, mortar, materials, equipment, tools and labor incidental to the reconstruction of the existing brick masonry arch complete in place to the limit shown on the plans.

**160.0 REPOINTED MASONRY**

160.1 General: This item shall conform to Section 6.09 REPOINTED MASONRY, of the Form 816, with the following section replaced:

160.2 Basis of Payment: This work will be paid for at the contract unit price per square yard for "Repointed Masonry" which price shall include all materials, equipment, tools and labor incidental thereto.

**210.0 UNDERDRAIN**

210.1 General: This item shall conform to Section 7.51 UNDERDRAIN AND OUTLETS, of the Form 816, with the following section replaced:

210.2 Basis of Payment: This work will be paid for at the contract unit price per linear foot for "6-inch Underdrain" complete in place, which price shall include pipe of the size specified, elbows, tees, wyes, couplings, fitting, trench excavation, geotextile, aggregate, sand, tools, material and labor incidental thereto.

There will be no direct payment made for capping, plugging or connecting underdrains or outlets to existing or proposed drainage systems or structures, but the cost thereof shall be included in the cost of the underdrain items involved.



**215.0 GEOTEXTILE SUBSURFACE DRAINAGE – (CLASS A)**

215.1 General: Work under this item shall conform to the requirements of Section 7.55 GEOTEXTILE of the Form 816, amended as follows:

215.2 Materials: Delete the first sentence of Article 7.55.02 and add the following:

Geocomposite drainage fabric (geotextile) for drainage of roadway base shall comply with the following or be a material approved by the engineer for use as a drainage layer to be placed above the Impervious Polyethylene Geomembrane Liner.

Configuration: Three layer system consisting of HDPE drainage core covered on both sides by non-woven geotextile

Min. Thickness:	280 mil
Min. Grab Tensile:	200 lb
Min. Tear Strength:	75 lb
Min. Puncture Resistance:	100 lb
Max. Grab Elongation:	50%

The non-woven geotextile shall be 100% polypropylene and shall be UV Resistant. Provide for review by the engineer the manufacturer's product data sheet listing technical data and tested physical and performance properties of the geotextile, a 6 inch square material sample, the manufacturer's written instructions for evaluating, preparing, and treating substrate, and installation instructions and details. The geotextile shall be provided with a manufacturer's warranty of 5 years or greater.

Acceptable items include:

- RoaDrain Geocomposite: Manufactured by Syntec Corp., Baltimore MD.
- Approved alternative

215.3 Construction Method: Add the following to Article 7.55.03:

The geotextile shall be installed in a manner that will not void the manufacturer's warranty by an experienced installer.

**220.0 IMPERVIOUS POLYETHYLENE GEOMEMBRANE LINER**

220.1 General: Work under this item shall conform to the requirements of Section 7.55 GEOTEXTILE of the Form 816, amended as follows:

220.2 Materials: Delete the first sentence of Article 7.55.02 and add the following:

Impervious polyethylene geomembrane liner shall be a high density polyethylene liner to act as an impermeable layer placed below the geocomposite paid for under "Geotextile (Subsurface Drainage – Class A)". The liner shall comply with the following or be a material approved by the engineer for use as an impermeable layer to be placed below the drainage layer.

Configuration:	Textured on both sides
Min. Thickness:	60 mil
Min. Density:	0.94 g/cc (ASTM D1505)
Min. Tear Resistance:	45 lb
Min. Puncture Resistance:	130 lb
Tensile Properties (ASTM D638)	
- Min. Yield Stress:	132 lb/in
- Min. Break Stress:	115 lb/in
- Max. Yield Elongation:	15%
- Break Elongation:	100%

Provide for review by the engineer the manufacturer's product data sheet listing technical data, tested physical and performance properties of the geotextile, a 6 inch square material sample, the manufacturer's written instructions for evaluating, preparing, and treating substrate, and installation instructions and details. The Impervious Polyethylene Geomembrane Liner shall be provided with a manufacturer's warranty of 5 years or greater.

Acceptable items include:

- HDPE Textured: Manufactured by GSE Lining Technology, LLC, Houston, TX.
- Approved alternative

220.3 Construction Method: Add the following to Article 7.55.03:

When forming seams, orientation shall be down slope and shall not run across the slope. In general, minimize the number of field seams and align seam overlaps so they are consistent with the requirements of the welding equipment being used.

The impermeable polyethylene liner shall be installed in a manner that will not void the manufacturer's warranty by a experienced installer. In general do not allow foot, equipment, or vehicular traffic on the installed membrane unless allowed by the manufactures written installation and protection instructions.

**230.0 METAL BEAM RAIL TYPE RB-350**

230.1 General: This item shall conform to Section 9.10 METAL BEAM RAIL, of the Form 816, amended as follows:

230.2 Materials: Weathering Steel shall be used for rail elements, terminal sections, and posts which shall meet the requirements described Article M.10.02 of the Form 816.

230.3 Basis of Payment: Add the following to Article 9.10.05:

R-B terminal section shall be paid for at the contract unit price for each "R-B Terminal Section (Weathering Steel)" installed and accepted which price shall include all materials, equipment, tools and labor incidental thereto.

**235.0 METAL BEAM RAIL ANCHORAGES**

235.1 General: This item shall conform to Section 9.11 METAL BEAM RAIL ANCHORAGES, of the Form 816, amended as follows:

235.2 Materials: Weathering Steel shall be used for rail elements, terminal sections, and posts as described Article M.10.02 of the Form 816.

**240.0 R-B 350 BRIDGE ATTACHMENT – VERTICAL SHAPED PARAPET**

240.1 General: Work under this item shall conform to the requirements of Section 9.10 METAL BEAM RAIL of the Form 816 amended as follows:

240.2 Materials: Add the following paragraphs to Article 9.10.02:

4. Concrete for footing of end post as indicated on the plans shall be Class 'A' concrete and comply with Section 6.01.

5. Anchor bolts for attachment to end post shall be as specified on the plans.

240.3 Construction Methods: Add the following paragraphs to Article 9.10.03:

The standard R-B 350 Bridge Attachment for a vertical shaped parapet shall be replaced with a steel post located at the ends of the stone masonry parapets. The posts for the attachment of the R-B 350 rail shall be installed plumb and inline with adjacent posts required for the bridge attachment transition. The contractor shall take all measurements and verify all elevations as needed to ensure proper fit and finish of the work.

240.4 Basis of Payment: Add the following paragraph to Article 9.10.05:

Section 3 – R-B 350 Bridge Attachment – Vertical Shape Parapet:

The cost for the Class 'A' concrete used for the end post foundation shall not be included in the cost of this item. The cost for the structural steel used for the end post shall not be included in the cost for this item. Rather, these items shall be measured and paid for under the respective items included in the contract.

**290.0 REMOVAL OF EXISTING MASONRY**

290.1 General: Work under this item shall conform to the requirements of Section 9.74 REMOVAL OF EXISTING MASONRY of the Form 816 amended as follows:

290.2 Description: Delete Article 9.74.01 in its entirety and replace with the following:

This work shall include the removal of all retaining walls and structures, or portions thereof, as indicated on the plans constructed of dry masonry, cement rubble masonry, and brick masonry the removal of which is necessary to complete the work. Stone masonry shall be salvaged and prepared for reuse. Brick masonry shall be disposed of and not used in any portion of the work.

290.3 Construction Methods: Replace the last sentence of Article 9.74.02 with the following:

The material excavated in order to perform the work shall be legally disposed of.

Add the following: Pneumatic hammers or any other method approved by the Engineer may be used to remove the masonry. Maximum 15 pound hammers shall be used for general removal of stone and brick. When removing stone and brick, the Contractor shall take necessary precautions to prevent construction materials, equipment and debris from dropping into the areas below the structure and into the stream.

The Contractor shall take necessary precautions to prevent any damage to the portions of the structure to remain. Any damage shall be repaired by the Contractor, as directed by the Engineer, and at no cost to the Town.

Removed stone shall be reused in the reconstruction of existing walls or structures, or in new construction, as indicated on the plans and shall be cleaned and thoroughly prepared for reused under this item. All existing material that is not salvaged due to damaged or deterioration, or which is in excess of that required for reuse to complete the work shall be considered debris. All debris shall be legally disposed of, from the site, by the Contractor.

290.4 Method of Measurement: Delete the second paragraph of Article 9.74.04 in its entirety.

290.5 Basis of Payment: Delete Article 9.74.05 in its entirety and replace with the following:

This work will be paid for at the contract unit price per cubic yard for "Removal of Existing Masonry", which price shall include all equipment, tools and labor incidental thereto.

**650.0 DUCTILE IRON PIPE (WATER MAIN)**

Reference to "District" in this Item refers to "The Metropolitan District".

650.1 General: The Contractor shall furnish and install ductile iron pipe, of the sizes indicated, and all the fittings and appurtenances to the lines and grades shown on the Contract Drawings, complete as shown, specified or directed, including but not limited to; bleeders, pressure reducing valves, vaults, bends, restraint, blow off assemblies, gate/butterfly valves, air valves, sterilization fittings, tapping sleeves, tapping gates, RCP sleeve, gate boxes, tees, thrust blocks and anchors, transporting materials, digging test pits, the clearing, trenching, disposing of unused excavated materials, removing and disposing of sections of the present water mains and concrete anchors, furnishing installing and field testing the pipelines complete with lacings and harnessing, concrete anchor / thrust blocks and utility identification tape, all trenching, rock removal, refilling trenches, filter fabric, furnishing additional material for refilling, trench compaction / testing, temporary and permanent surface restoration, miscellaneous grading, sheeting, bracing, pumping and all incidental work where required, to the specifications and details of the District, except as otherwise herein provided for.

650.1

Materials:

Ductile Iron Pipe - Submittals: Six (6) sets of the manufacturer's literature and/or shop drawings for the materials of this section shall be submitted for approval. The Contractor shall furnish detailed drawings as follows and no work shall be fabricated until they have been approved by the Engineer:

1. Dimensions and general details for typical length of pipe.
2. Detail of joint between pipes for both push-on and restrained joints together with installation instructions.
3. Dimensions and general details for all fittings including joint details for both mechanical and restrained joints.
4. Location plans or lists showing number of pipes and fittings and other such information as needed for installation.

Prior to pipe-laying, the Contractor shall dig test pits where the new pipe connects to the present water main to ascertain the location, elevation and cross sectional dimensions of the present mains.

Pipe Specifications: All ductile iron pipe with push-on joints shall be the 60-42-10 grade cast in revolving molds in full accord with the following American National Standard, except for details for the joints and other modifications stated herein: "Ductile Iron Pipe, Centrifugally Cast in Metal Molds or Sand-Lined Molds, for Water or Other Liquids".

ANSI/AWWA C151/A 21.51, furnished in 18-foot or 20-foot lengths. Push-on joints for such pipe shall be in accordance with ANSI/AWWA C111/A 21.11.

All requirements of the American National Standards Institute Specifications will be rigidly enforced and the foundry shall submit regularly to the Engineer, single copies of the report of tensile tests and low temperature impact tests as required in Section 51-12 and 51-13 of the ANSI/AWWA C151/A 21.51.

The Contractor shall submit to the Engineer a certified statement that the inspection and all of the specified tests have been made and met as required in Section 511.4.2 of ANSI/AWWA C151/ A21.51.

The ductile iron pipe to be furnished under this Contract shall conform to the following dimensions:

Size (Inches)	Thickness (Inches)	Thickness (Class)
4	0.35	54
6	0.37	54
8	0.39	54
12	0.43	54

Where shown, specified or ordered, the pipe shall have push-on joints of the type which employs a single elongated, grooved rubber gasket to affect a watertight joint seal. The joints shall conform to the latest American National Standard for "Rubber Gasket Joints for Ductile Iron and Gray Iron Pressure Pipe and Fittings", ANSI/AWWA C111/A21.11, except as otherwise specified herein. The rubber gaskets shall be manufactured from high quality rubber satisfactory to the Engineer and shall be similar to the gaskets used in the Tyton joint as manufactured by the United States Pipe and Foundry Company or the Fastite joint as manufactured by the American Cast Iron Pipe Company or the Grip-Tite joint as manufactured by Griffin Pipe Products Co. or approved equal.

Where shown, specified or ordered, the pipe shall have restrained joints of a type which employs a single elongated, rubber gasket to affect a watertight joint seal. The joints shall conform in general to ANSI/AWWA C111/A21.11. The rubber gaskets shall be manufactured from high quality rubber satisfactory to the Engineer. The restrained joint pipe shall be as manufactured by McWane, Super Lock, TR Flex, or approved equal.

The grooved rubber gaskets and joint lubricant shall be furnished with the pipe and shall be considered included in the price bid per linear feet of pipe. The gasket shall be plainly identified as to pipe size and packaged in a suitable and satisfactory manner for shipment.

Each pipe shall have cast or stamped on it the maker's name or mark, the year in which the pipe is cast, and the letters "DI" or "DUCTILE" as required by the American National Standards Institute Specifications. The weight and thickness class shall be painted on each pipe, as required by the American National Standards Institute Specifications, and a record of weight for each pipe before the application of a lining or coating shall be submitted to the Engineer.

Fitting Specifications: All ductile iron fittings to be furnished under this Contract shall conform to the American National Standard for "Ductile-Iron and Gray-Iron Fittings, 3-inch through 48-inch, for Water and other Liquids", ANSI/AWWA C110/A21.10. In addition to the marking required by the American National Standards Institute Specifications, the year of casting shall be cast on all fittings. Single copies of the results of tests required by the ANSI/AWWA C110-A21.10 shall be submitted to the Engineer.

Bolt holes in the mechanical joint bells of all fittings shall straddle the vertical centerline of the fitting (fitting laying in horizontal position).

Unless otherwise shown, specified or ordered, all fittings shall be mechanical joint (MJ).



Joint Accessories: All joint accessories shall be furnished with each pipe and fitting and shall be plainly identified as to pipe size. A certified statement that all required tests on the joint accessories have been made and met as specified shall be submitted to the Engineer.

Lining and Coating: All pipe and fittings, except sleeves, caps and plugs shall be lined with cement mortar in accord with the American National Standard for "Cement Mortar Lining for Ductile-Iron Pipe and Fittings for Water", ANSI/AWWA C104/A21.4. However, linings with thickness twice those specified in Section 4-10.1 shall be furnished. Thickness determinations, in accord with Section 4-9, shall be made on at least one fitting of each type.

All pipe and fittings, including steel sleeves, caps, plugs, tees, bends and reducers, shall be coated inside and outside with an approved bituminous material, neither sufficiently soft to flow when exposed to the summer sun, nor brittle enough to crack and scale off when exposed to temperatures below freezing.

Coating may be applied by painting, dipping or spraying, but in no case are the pipe fittings or the coating material to be heated to a high enough temperature to be detrimental to the cement lining. In addition, the coating of the interior shall conform to the requirements of ANSI/AWWA C104/A21.1.

The Contractor shall submit to the Engineer a certified statement that the inspection and all of the specified tests have been made and met.

**THE FOLLOWING ARE ACCEPTABLE PIPE MANUFACTURERS:**

Atlantic States Pipe (McWane)  
United States Pipe & Foundry Co.  
Griffin Pipe Products, Inc.  
Clow Corp. (McWane)  
McWane

Inspection: All pipe and fittings shall be subject to inspection by the Engineer after delivery to the job site and may also be subject to inspection at the foundry by a representative of the District.

Harnessing Specifications: Eyebolts and lacing rods shall be of A-36 steel as manufactured by Star National Products, Columbus, Ohio or approved equal. All components shall be hot -dipped galvanized.

Retainer glands for mechanical joints shall conform to ANSI/AWWA C111/A21.11 and the following additional requirements:

1. All retainer glands shall be ductile iron and all retaining devices shall be heat treated ductile iron.
2. All retainer glands shall have a minimum rated working pressure of 250 psi.

The retainer glands shall be Megalug Series 1100 as manufactured by EBAA Iron Sales, Inc. Eastland, Texas or approved equal.

Components of the harnessing system for push on joint ductile iron pipe shall be in general accord with the above requirements for lacing rods and retainer glands. The

harnessing system shall be the Series 1100HD Megalug Harness or Series 800 Coverall, both as manufactured by EBAA Iron Sales, Inc., Eastland, Texas or approved equal.

Chlorination Tablets and Cement: The District will furnish the chlorinating tablets and cement for cementing tablets to each length of pipe. See Table in Section 1.16 for the required number of tablets to be cemented to each pipe.

Trench Refill: Trench refill materials shall meet the following requirements:

Native Backfill: Native backfill shall consist of granular soil excavated on site meeting the approval of the Engineer. Materials shall be of such a nature that they will form a stable dense fill. Materials shall not contain stones larger than 6-inch, vegetation, masses of roots, individual roots more than 12-feet long or more than ½-inch in diameter, trash, clays, or plastic fines. Organic matter shall not exceed two percent (2%). Non-plastic fines (silts) shall not exceed 20 percent (20%).

Bank Gravel: Bank gravel shall conform to the requirements of Article M.02.01-2, CDOT Form 816.

Crushed Stone: Crushed stone shall conform to the requirements of Article M.02.01-1 Grading A, CDOT Form 816 and Sub article M.02.02-2(a), CDOT Form 816, for loss on abrasion.

Granular Base: Granular base shall conform to the requirements of Article M.02.03, Grading "C", CTDOT Form 816.

Sand: Sand shall conform to the requirements of Sub article M.11.04c, CDOT Form 816.

Utility Identification Tape: Utility identification tape shall be 6-inch wide non-detectable, designed to withstand extended underground exposure, colored blue and be durably imprinted with an appropriate warning indicating the presence of the buried pipe.

Ductile Iron Pipe and Fittings: Refer to the "Ductile Iron Pipe (Water Main)" specification.

Gate Valve, Extension Stem and Gate Box: Refer to MDC Detail.

Concrete anchor/ Thrust blocks: Anchors and thrust blocks shall be Class "A" concrete conforming to Article M.03.01.

Harnessing: Refer to MDC Detail.

Filter fabric: Fabric shall conform to Article M.08.01-26.

Utility Identification Tape: The tape shall be 4 inches wide, designed to withstand extended underground exposure, colored blue and be durably imprinted with an appropriate warning indicating the presence of the buried pipe.

650.3

Construction Methods:

Transporting and Distributing Pipe: The Contractor shall transport the pipe and fittings from the place of manufacture, shall secure all permits which may be necessary, and comply with the requirements of the Connecticut Bureau of Highways, Cities and Towns, concerning heavy transporting over State, City and Town highways.

During loading, transportation and unloading, more than ordinary care shall be taken to prevent injury to the pipes. Such work shall be done with each section of the pipe under full control at all times and under no condition shall a pipe be dropped on the ground.

Pipes shall be placed on sand beds or other methods may be employed to avoid chances of pipe being frozen to the ground surface.

In distributing the pipe in the field, as permitted, each piece shall be placed as near as possible to the point where it is to be installed and faced in the proper direction. In case any pipe received damage from handling or other cause and made unacceptable to the Engineer, it shall be replaced with a new pipe at the expense of the Contractor. The Contractor is cautioned that State, City, or Town authorities may not permit storing pipe, etc., within street or highway limits.

Clearing Trees and Bushes: No trees within streets and highways, or adjacent to the normal trench therein, shall be damaged or removed. In streets and highways where there is no permanent paving, the Contractor shall, unless otherwise directed, remove and dispose of only those trees, bushes or shrubs required for construction and approved by the Engineer. The unlimited removal of trees and brush will generally not be required or permitted. All trees, bushes or shrubs which are not to be removed shall be preserved and protected by the Contractor. Should any trees, bushes or shrubs, which are to be preserved and protected, become damaged by the conduct of the work, the Contractor shall replace them at his own expense. Brush, small branches, trash, large trunks, stumps and all other surplus material and debris shall be removed from the site of the work.

Trenching: Prior to any excavation, the Contractor shall notify all affected utilities in accord with Public Act 77-350 (CALL BEFORE YOU DIG 1-800-922-4455).

The trench for the pipe shall be 18-inches beyond the outside of the barrel of the pipe on each side, the top of the barrel of the pipe shall be as shown on the Contract Drawings or as directed by the Engineer; and the bottom of the trench shall be at the bottom of the pipe. The Contractor alone shall be responsible for the stability and safety of the trenches and adjacent structures, and shall use such trench support and bracing as necessary without additional payment therefor. Pavement cuts shall be made with the edges reasonably smooth and without cracking or damage to the pavement outside the limits of the portion excavated. The methods used and the location of such cuts shall conform to the requirements and specifications of the City or State. Repairs to pavement shall be made in accordance with the requirements and specifications of the City/Town or State.

In any area to receive fill, no pipe trench shall be excavated until the fill has been placed and compacted to a level at least 3-feet above the top of the pipe to be installed.

The Contractor may be required to excavate locally to determine the location and depth of existing underground structures on the lines of the pipe well in advance of the pipe laying. There will be no additional payment for this work, including backfilling and temporary surfacing.

Sheeting, Bracing and Pumping: The Contractor shall furnish and put in place such sheeting and bracing as may be necessary, to support the sides of the excavation, to prevent undermining of the pavement or to protect from possible injury any pipes, sewers, ducts, poles, conduits or other structures existing in the streets, or highways, and shall remove such sheeting and bracing as the trench is refilled unless the Engineer shall order it left in place.

The Contractor shall maintain all excavations in proper condition for carrying on the work, and to this end shall do all bailing, draining, or pumping which may be necessary to keep the trenches or other excavations free of water. No direct payment will be made for this

work but the cost thereof will be considered as having been included in the price bid per linear feet of pipe.

If the Contractor installs and operates wellpoints on any section of the work, the expense of the same shall be borne by the Contractor.

Protection of Pipes, Drains, Culverts, etc.: All existing gas pipes, water pipes, sewers, drains, manholes, catch basins, culverts, electrical conduits, telephone ducts, utility poles or other structures which are uncovered by the excavation, and which do not, in the opinion of the Engineer, require to be changed in location, shall be carefully supported and protected from injury by the Contractor; and in case of damage, they shall be restored by him without compensation; therefore, to as good condition as that in which they were found and shall be kept in repair during the existence of this Contract.

Laying Ductile Iron Pipe: Proper and suitable tools and appliances for safe and convenient handling and laying of pipe shall be used, and care shall be taken to prevent the coating of the pipe from being damaged, particularly on the inside of the pipes. The Contractor shall not start any pipe work until he has satisfied the Engineer that he has on hand and available the following minimum equipment:

1. Wheel pipe cutters, hydraulic pipe cutter or a pipe saw for the sizes of pipe to be laid;
2. Ratchet type socket wrenches for mechanical joint bolts and nuts;
3. At least two expandable pipe stops of the proper size for closing the end of the pipe being laid when not actually laying pipe.

All pipes shall be carefully examined for defects and no pipe or other casting shall be laid which is known to be defective, and should any defective pipe or other casting be discovered after being laid, it shall be removed and replaced with a sound casting at the expense of the Contractor.

The pipe shall be laid upon sound soil, cut true and even so that the barrel of the pipe will have a bearing for its full length. In the event the trench is excavated below the grade of the bottom of the pipe, the trench will be brought up to grade with acceptable crushed stone or processed gravel, pneumatically tamped, at the expense of the Contractor, before the pipe is laid.

The utility identification tape shall be placed approximately two (2) feet above the top of the pipe.

During the course of installing the water mains, the Contractor shall cement Hypochlorite HTH tablets to the inside top of the pipes as specified in the following table:  
Number of 5 Gram Hypochlorite tablets required for 25-ppm doses.

PIPE DIA. (Inches)	NUMBER OF TABLETS PER LENGTH OF PIPE
4	1
6	1
8	2
12	4

Tablets are to be attached by an adhesive such as Permatex Form-A-Gasket No. 2, to the top of each pipe.

When not actually laying pipe (e.g. overnight, weekends, holidays, etc.) the open ends of the pipe shall be kept plugged with approved watertight night caps furnished by the Contractor.

The Contractor shall take all necessary precautions to prevent water from entering the pipe during installation of the pipeline.

Unless shown otherwise on the Contract Drawings or directed otherwise by the Engineer, the pipeline shall be installed a minimum of four (4) feet six (6) inches below finished grade. The pipeline shall also be installed to provide at least eighteen (18) inches of vertical clearance between the water pipe and storm drains or sanitary sewers.

**Cutting Pipe:** Whenever the pipes require cutting, an approved saw, wheel, or hydraulic type cutter shall be used. This work shall be done by the Contractor without extra compensation, in a manner satisfactory to the Engineer, and only experienced men shall be engaged thereon.

**Joints:** On pipe with rubber gasket push-on joints, the gasket shall be installed in the socket of the pipe previously laid and the gasket then lubricated. The plain end of the pipe being laid shall then be inserted and pulled or pushed to the full depth of the socket. An approved jack-type tool shall be used to assemble pipe 10-inches and larger. Plain ends of cut pipe shall be filed or ground to a taper to prevent damage to the gasket during insertion.

On fittings, butterfly and gate valves with mechanical joints, the follower ring and rubber gaskets shall be placed on the plain end of the pipe being (or previously) laid and entered into the socket of the fitting. The gasket shall then be evenly seated in the socket, the follower ring moved up to the face of the gasket and the "T" bolts inserted and made finger tight. The "T" bolts shall then be tightened with a ratchet or torque wrench to between 60 and 80 foot-pounds. See S-1.19 for additional joint requirements.

**Joint Restraints:** Where and as shown on the Contract Drawings, or as directed by the Engineer, retaining glands or eye bolts and lacing rods shall be installed with the standard lacing details shown for mechanical joint pipe or fittings.

The retaining glands shall be installed in lieu of the standard mechanical joint gland. The "T" bolts shall be tightened with a ratchet or torque wrench to between 60 and 80 foot-pounds. Only then shall the set screws be tightened to a maximum of 70 foot-pounds, tightening 180 degrees apart and making a final check with the wrench to ascertain that all set screws have 70 foot-pounds. The joint is then complete. Torque settings shall be done with the pipe laid in the trench in place.

Retaining glands shall also be installed adjacent to the pipe bells. No "T" bolts will be installed; however, the set screws will be installed as above.

The standard mechanical joint gland placed behind the pipe shall be installed snugly against the back of the bell to preclude movement. No "T" bolts will be installed on this gland.

Other special lacing or harnessing, if shown on the Contract Drawings, or directed by the Engineer shall be installed by the Contractor to the satisfaction of the Engineer.

**Refilling Trenches:** As soon as practicable after the pipes have been laid, the trenches shall be refilled at least to a level 2-feet above the top of the pipe with approved gravel,

deposited in layers no more than 6-inches in depth and satisfactorily compacted with pneumatic hand tampers, each layer to be leveled and thoroughly compacted to the satisfaction of the Engineer before the next layer is deposited. There will be no additional payment for necessary borrow to refill to this level. Special care shall be taken to consolidate the gravel under the pipes and the whole work of refilling shall be done in a manner which will prevent subsequent settlement and injury to the pipe. Above this level except for the surfacing material, the Contractor may use approved material from the trench excavation.

**Trench Backfill:** Backfill above the 24-inch level will comply with and be paid for under the appropriate items included in this Contract.

**Frost in Trench or Refill:** Every effort shall be extended to eliminate the presence of frost in the bottom and sides of the trench and refill material. The Contractor shall cover and heat the trench or take such other means as necessary to eliminate the frost and chance of subsequent pipe settlement.

**Cleaning:** Prior to the installation of the pipeline, the Contractor shall clean the interior of the pipelines to the satisfaction of the Engineer, by such means as the Engineer approves.

**Filling, Sterilizing and Flushing:** At the location(s) as shown on the Contract Drawings or as ordered by the Engineer, the Contractor shall install an appropriately sized corporation stop on the crown of the pipe for sterilization testing. All costs for providing and installing said corporation stop(s) shall be included in the unit price bid per foot of pipe or pipeline installed. As soon as practicable after the Contractor has completed installation of the pipeline to include a successful leakage and hydrostatic test, the District will fill, sterilize and flush the pipeline. The Contractor shall supply labor to assist the District in filling, sterilizing and flushing the pipeline. If the pipeline is not connected to an existing operating water main, the Contractor shall furnish all labor, materials, equipment, at no extra cost to the District or State, to temporarily connect a District water main to the pipeline to be tested. The Contractor will not be charged for the District water used in this operation. The Contractor shall be responsible for labor, equipment and material necessary for erosion control.

In the event the Contractor has allowed ground, surface or other unclean water to enter the pipeline during installation, thereby rendering the hypochlorite tablets in the pipe ineffective, or the pipeline must be dewatered to allow for Contractor repairs due to faulty installation, the contractor shall engage the services of an outside contractor to chlorinate and sterilize the main by injecting a hypochlorite solution into the pipeline under the supervision of the District. The cost of this work, including installation of chlorination fittings, shall be paid for by the Contractor.

Subsequent to sterilizing and flushing the water main(s), the District will test the water in accord with required state regulations. Should the water fail to pass the required tests and it is determined that the failure was caused by the Contractor's operations, all costs for re-sterilization, re-flushing, re-testing, etc., shall be borne by the Contractor.

The Contractor will attempt to minimize any damage to the road work that may occur during the flushing operation; however, he shall repair any such minor damage and the cost thereof will be considered as included in the price bid per linear feet of pipe.

Procedures and Requirements for Disinfecting Water Mains and Piping Systems

The Contractor installing water mains and appurtenances such as pipe, valves, fittings and accessories within the District service area is responsible for disinfecting the water main and pipe sections. The District requires the Contractor to adhere to the strict standards stipulated in latest edition of AWWA C651, "Standard for Disinfecting Water Mains" when performing disinfection procedures. The standards represent the physical, chemical and bacteriological parameters that must be satisfied prior to determining if newly installed water mains can be placed into service.

Subsequent to performing the disinfection operation, the District will collect and analyze two complete sets of water samples. The two sets of water samples will be collected approximately twenty-four hours apart from each other. The District will compare the results from the water samples collected to the maximum allowable limits for each parameter. If all parameters are satisfactory then the water main is considered to have passed and can now be opened for service. It is important to note that if any one parameter fails then two additional water samples will be collected twenty-four hours apart from each other. The parameters used to compare to the water sample results are listed in Table I.

Table 1

Parameter	Maximum Allowable Limit
pH	6.4-10.0
Color	15 units
Turbidity	1.0 NTU
Odor	2
Hardness	60 ppm
Specific Conductance	150 micromhos @ 25 C
Coliform Bacteria	0 per 100 ml.
Standard Heterotrophic Plate Count	< 500 per ml. @ 35 C
Chlorine Residual	< .1-.8
VOC*	**

\*Volatile Organic Compounds (VOC) are required for all water projects whether developers projects or contracts.

\*\*Volatile Organic Compounds (VOC) maximum containment levels vary depending on the organic chemical. These levels are available from the District if desired and can also be found in Public Health Code Section 19-13-B102.

A successful disinfection process begins at the early stages of construction. The Contractor must protect piping systems which includes but is not limited to covering the ends of pipe while stored on site, keeping all copper tubing clean and utilizing sanitary methods when handling pipe materials. Heavy particulate matter generally contains bacteria and may prevent the chlorine concentrations used from contacting and killing harmful organisms. If no contamination is allowed into the water main at any point in the process then there should be little problem with satisfying the parameters as previously specified. It must be remembered that the final water quality test(s) are not the primary means for ensuring the sanitary condition of a water main. The sanitary handling of materials, the practices during construction, and the continual inspection of the work are the primary means for ensuring the sanitary condition of the water main.

During the installation of water mains between the sizes of 4 through 12-inches, the Contractor is required to utilize a modified Tablet Method as described in Section 5.1 of the AWWA C651 standard. The appropriate number of five-(5) gram calcium hypochlorite tablets as shown in Table 2 shall be cemented in each length of pipe by the Contractor. Tablets are to be attached, by an approved adhesive such as Permatex No

2c, to the top of each pipe. It is important to make sure that the tablets have not exceeded their expiration date and that water is kept out of the water main during construction. The Contractor is cautioned that the tablets are not to be left in pipes above ground over night or on the job site where they can come in contact with children or animals. The tablets are also adversely affected by elevated levels of moisture, i.e. humidity or other sources of moisture.

Table 2

Number of 5 gram Hypochlorite tablets required for 25-ppm dose

PIPE DIAMETER (INCHES)			NUMBER OF TABLETS PER LENGTH OF PIPE
			18                      20'
4"	1	1	
6"	1	1	
8"	2	2	
10"	3	3	
12"	4	4	

The District supplies the tablets for the water main construction. Proper placement of the tablets on the top inside of the water main when in position, proper filling of the water main and disinfection contact time is critical to the success of the disinfection procedure by the tablet method. Subsequent to completing the new water main, the District will assist the Contractor in filling the pipe using District water from the active water distribution system. The water shall remain in the new water main a minimum of 48 hours before flushing. It is important to note here that the new water main shall be kept isolated from the active distribution system using a physical separation until disinfectant has been flushed and satisfactory bacteriological, physical and VOC testing has been completed. Operation of all valves used in filling and flushing the line shall be performed by District personnel.

After final flushing and before placing the newly constructed water main in service, District forces will take samples using a copper "Goose Neck" device approximately every 1,200 feet along the new water main and perform the appropriate bacteriological, physical, and VOC testing as indicated above. Typically, the goose neck is drenched in a chlorine solution to make it sterile prior to taking the sample.

The Contractor is reminded that for a complete test procedure, the AWWA standard requires two consecutive sets of samples, 24 hours apart, to be tested for bacteriological and physical quality. The District requires the sample be tested for Heterotrophic Plate Count (HPC) and that the result of the test be less than 500 bacteriological colonies per milliliter as part of the acceptance criteria. The HPC analysis is in addition to the requirement for the absence of total and/or fecal coliform organisms. These tests require four (4) consecutive working days for the results to be obtained. If the water main fails these tests, the District will require additional disinfection, flushing and testing as described below. All expenses for this additional work will be the responsibility of the Contractor.

Flushing:

The Contractor shall make arrangements with the District to flush the system subsequent to disinfection. The District will be responsible for operating the gate valves in the street if necessary. The Contractor shall be responsible for supplying equipment necessary to perform the flushing operation and determining where the water will drain during the



flushing operation so as not to flood sensitive areas or cause damage to property. Also, it is extremely important to isolate the section of pipe to be disinfected to avoid any backflow condition so no disinfectant water with an elevated chlorine level enters the active water distribution system during the flushing operation.

The pipelines must be flushed at a minimum of 2.5 feet per second to ensure adequate removal of contamination. Pumping requirements must be anticipated as well as flow rates and routing of water from blow-offs to drainage facilities and drainage requirements for flushing water. It is important to note that during the summer months, water mains tend to take longer to disinfect due to higher ambient temperatures increasing the bacterial count. Usually, additional flushing will result in successfully disinfecting the water main.

Hypo-Chlorination Procedures:

Upon exhausting all efforts to get the water main to successfully pass disinfection tests using the tablet method or if the new water main is 16-inches or greater, the Contractor will perform sodium hypo-chlorination. Hypo-chlorination utilizes a concentrated dose of chlorine solution, usually 25 ppm per minute for a 24 hour period, to eradicate bacterial contamination. This is a critical operation that requires skilled personnel. The District has developed safe and effective hypo-chlorination procedures. These procedures allow for disinfecting a new section of the MDC water distribution system, minimizing the risk to the field crews, to customers and to the environment. These procedures are to be followed when disinfecting all new pipelines which utilize the injection of sodium hypochlorite.

1. Construction inspection ensures that the new pipeline is ready to be disinfected with sodium hypo-chlorite. Typically, new gate valves are opened and the existing gate valves isolating the distribution system remain closed; sterilization sampling and injection fittings and the necessary blow offs are installed as specified, shown or directed. Upon completing the installation of the new pipeline and appurtenances the process to disinfect the pipeline will commence.

2. Construction inspection meets with the Contractor and its outside-vendor on the project site to review the construction plans and discuss protocol for disinfecting the new pipeline.

3. Construction inspection initiates changes and recommendations, if any, to the pipeline installation. Subsequent to implementing any changes, Construction inspection ensures the pre-chlorination process is complete, i.e.: filling, flushing, hydrostatic testing the new pipeline. The Construction inspector will take samples of the new pipeline, subsequent to flushing, to ascertain what degree of contamination exists.

4. Construction inspection ensures each existing gate valve in the water distribution system that is physically tied into the new pipeline is "locked out" using a 2x4 stud lumber. The stud with its ends painted blue is placed in the gate box and extended up to just below the gate box cover to remind MDC personnel not to operate the gate valve. Additionally, a tag attached to the 2x4 with the wording "Do Not Operate Gate- Water is Super Chlorinated", and visible to anyone who accesses the gate box, can be a further deterrent to accidentally operating a gate. The tag should be signed by the Construction inspector of record and is the only individual responsible for removing the 2x4 from the gate boxes.

5. The Contractor and its outside-vendor including its crew with the hypo-chlorination equipment meet at the project site with Construction inspection. Everyone

involved with the disinfection operation is visually shown the gate valve locations with the marked 2x4s; the disinfection team is reminded that no one is to operate these gates unless specifically directed by Construction inspection personnel.

6. The Contractor and outside-vendor's crew set up and connect hypo-chlorination equipment to the pipeline and inform construction inspection disinfection has commenced. Construction inspection opens gate valve(s) to allow flow of the hypo-chlorination solution into the new pipeline.

7. The Operations department through their dispatcher is notified that the pipeline is under hypo-chlorination and not to operate any gate valve physically connected to the new pipeline. If mis-communication occurs then the 2x4 stud lumber with the ends painted blue will remind the Operations workforce not to touch the gate valve.

8. Predicated on the advice from Contractor's outside-vendor, the pipeline will remain hypo-chlorinated for typically 24-48 hours. After the disinfection time is expended, the de-chlorination process commences. This process includes flushing into either a sanitary or storm sewer line through a blow off connection. During the flushing operation a de-chlorination monitoring device and neutralizing agent (ascorbic acid) are used to render the super-chlorinated water safe for the environment.

9. The Contractor and its outside-vendor's crew with the assistance of Construction inspection perform the initial flushing so the chlorine residual in the pipeline can be monitored.

10. During the flushing operation, Construction inspection shall determine which 2x4s shall be removed from the gate boxes, starting with the feed gate and systematically open gate valve(s) to promote effective flushing. Note: when the flushing is completed, the gate boxes are again "locked out" by Construction inspection.

11. Effective flushing means to first flush the pipeline slowly towards the blow off to achieve low chlorine residual (the chlorine residual in the new pipeline should match that of the residual typically found in the surrounding area of the MDC's distribution system) for the entire length of the new pipeline. This effort is critical so as to minimize the chance of sending a super-chlorinated slug of water into existing sections of the water distribution system. SUPER-CHLORINATED WATER CAN CAUSE INJURY.

12. Subsequent to achieving the acceptable chlorine residual, Construction inspection performs high velocity flushing directed toward the blow off to force a final scouring of the pipeline interior wall.

13. Construction inspection will take water samples (bacteriological and physical samples in proper bottles and a volatile organic carbon sample) and transport them to the MDC laboratory for analysis. Construction inspection is required to complete a "Sample Collection\Chain of Custody" form. If all the analyzed parameters pass the established testing criteria for 24 hours and 48 hours, then Construction inspection has the authority to open the water main for service. Only at this time does the Construction inspector of record have the authority to remove any remaining 2x4s from the gate boxes.

14. Construction inspection will notify operations that the new water main is in service.

Hydrostatic Testing: The Contractor shall test the pipeline for leakage between test bulkheads and/or main valves. The pipeline will be filled with water and tested in accord with the latest ANSI/AWWA C600 under a pressure of 150 psi. Under the test pressure,

all visible leaks shall be made tight to the satisfaction of the Engineer. The total leakage per 24 hours from the line thus tested shall not exceed the requirements for leakage as specified in the latest ANSI/AWWA Standard for "Installation of Ductile Iron Water Mains and Their Appurtenances", C600. Visible leaks shall be repaired by the Contractor even though the total leakage of the portion in question may be less than the above-mentioned permissible limit. Test pressure shall be applied for at least two hours and as much longer as required to permit inspection for leaks. Should the leakage exceed the maximum specified amount and investigation show this leakage to be at the joints or caused by defective work elsewhere, such defective work shall be repaired to the satisfaction of the Engineer or, if he so orders, the pipe or pipes shall be replaced by the Contractor at his own expense and repairs or replacement shall be continued and the test repeated until the leakage under the test pressure is within the limit prescribed and the work left in a manner entirely satisfactory to the Engineer.

The District will not charge the Contractor for District water used for testing. The Contractor shall be responsible for any damage to the pipeline or to adjoining property due to the testing and shall furnish all labor, material and equipment for testing.

No direct payment will be made for any work done or materials used in making the pipeline tight.

**Air Valve Assembly:**

All brass fittings shall be of standard design generally used by water utilities and be in accord with ASTM B62 and ANSI/AWWA C800.

The corporation stops and angle valves shall be of good, tough, composition bronze well mixed and free from flaws and imperfections. The corporation stops shall be of a type suitable for use in ductile iron mains. The inlet end shall have an inlet taper thread type known as the "Mueller Taper Thread".

Compression fittings, valves, etc. shall be of the design employing the pipe clamp feature.

The gate valve box shall conform to the following requirements:

1. Cast iron shall conform to ASTM A48, Class 25.
2. Top section shall be of the top flange design and shall have no bead on the bottom.
3. The word "WATER" shall be cast with raised letters in the center of the cover.
4. Base section shall be of the Dwyer design which centers the operating nut for positive access to the valve.
5. For specific gate box details, see the MDC Details.

**Inspection Before Installation:** All tubing and fittings shall be carefully examined for defects and no material shall be installed which is known to be defective and should any defective tubing or fitting be discovered after being installed, it shall be removed and replaced with sound material at no additional cost to the District.

**Installation:** The air valves, chlorination valve and blow off shall be installed according to the details and to the satisfaction of the Engineer. To properly receive the air valve or

other assembly the ductile iron pipe shall be drilled and tapped. All tapped holes for corporation stops shall be tapped Mueller Thread.

All tapped holes in ductile iron pipe shall be cleaned by running the correct size tap into the hole immediately prior to installing the corporation.

Gate valve boxes shall be set plumb and centered on the fitting, etc. Earth fill shall be carefully tamped around the gate box to a distance of 4 feet on all sides of the box or to the undistributed trench face, if less than 4 feet.

Excavation and refill shall conform to the requirements under other applicable Contract Sections.

12-Inch and Smaller Gate Valves:

Quality Assurance: All gate valves, accessories and gate boxes shall be inspected and tested at the foundry as required by the standard specifications to which the material is manufactured.

A certified statement that inspection and all of the specified tests have been made and met shall also be submitted.

All gate valves, accessories and gate boxes shall be subject to inspection by the Engineer after delivery to the job site and may also be subject to inspection at the foundry by a representative of the District.

In addition the District reserves the right to have any or all materials inspected and/or tested by an independent service at either the manufacturer's plant or elsewhere. Such inspection and/or tests shall be at the District's expense.

A certified statement that inspection and all of the specified tests have been made and met shall also be submitted.

Gate Valve: The gate valve shall conform to ANSI/AWWA C500, ANSI/AWWA C509 and the following additional requirements:

1. Valve shall be double disc or resilient sealed.
2. Bolts and nuts for connecting O ring seal plates and bonnet to body shall either be copper silicon alloy or stainless steel.
3. Valve shall be furnished with O ring seals utilizing two O rings, consistent with appropriate specifications.
4. Valve shall have mechanical joint ends, unless otherwise specifically indicated, which shall conform to ANSI/AWWA C111/A21.11. All joint accessories shall be furnished with each valve.
5. Direction to open (right hand or left hand) shall be as shown on the contract Drawings.
6. Operating nut shall be 2" square.

Gate Valve Box: The gate valve box shall conform to the following requirements:

1. Cast iron shall conform to ASTM A48, Class 25.

2. Top section shall be of the top flange design and shall have no bead on the bottom.
3. The word "WATER" shall be cast with raised letters in the center of the cover.
4. Base section shall be of the Dwyer design which centers the operating nut for positive access to the valve.
5. For specific gate box details, see the MDC Details.

Extension Stem: The extension stem shall be fabricated from steel conforming to ASTM A 36. Galvanizing shall conform to the latest edition of ASTM A 123.

Inspection Before Installation: The gate valve, gate box, etc. shall be subject to a careful inspection before being installed. The valve shall be run through a full open close cycle to insure proper operation.

Installation of Gate Valve: The gate valve shall be installed according to the details shown and to the satisfaction of the Engineer.

All debris and foreign material shall be cleared from valve openings and seats. All mechanisms shall be checked and all nuts and bolts checked for tightness.

The valve box shall be set plumb and centered directly over the operating nut of the valves. Earth fill shall be carefully tamped around the valve box to a distance of 4 feet on all sides of the box or to the undisturbed trench face, if less than 4 feet.

Where and as shown on the Contract Drawings, or ordered, a valve extension stem shall be installed. An extension stem will be ordered when the valve-operating nut is more than 4.5 feet below finished grade.

Excavation and refill shall conform to the requirements under other applicable Contract Sections.

Blow-Off Assembly:

Quality Assurance: All blow off assemblies including gate valves and fittings shall be inspected and tested at the foundry as required by the standard specifications to which the material is manufactured.

All blow off assemblies including valves and fittings shall be subject to inspection by the Engineer after delivery to the job site and may also be subject to inspection at the foundry by a representative of the District.

In addition, the District reserves the right to have any or all blow off assemblies including valves, fittings and special castings inspected and/or tested by an independent service at either the manufacturer's plant or elsewhere. Such inspection and/or the tests shall be at the District's expense.

A certified statement that inspection and all of the specified tests have been made and met shall also be submitted.

Inspection Before Installation: Blow off assemblies including gate valves, pipe, fittings, gate boxes, etc. shall be subject to a careful inspection before being installed. Valves shall be run through a full open close cycle to insure proper operation.

Installation of Blow-off Assemblies: Blow off assemblies including piping, gate valves, fittings, etc. shall be installed according to the details shown and to the satisfaction of the Engineer.

All debris and foreign material shall be cleared from valve openings. The blow off assembly shall be set plumb. Blow off assemblies and connecting pipe shall have at least the same depth of cover as the distributing main.

Special trench refill shall be placed over the pipe and fittings from the bottom of the trench to 2 feet above the top of the pipe and fittings.

Ductile iron pipe and harnessing shall be installed in accord with the specifications.

The utility identification tape shall be placed approximately two (2) feet above the top of the pipe.

Gate valves and gate boxes shall be installed in accord with the specifications.

Three-quarter inch (3/4") crushed stone, special trench refill and concrete shall be placed in accord with the specifications.

Excavation and refill shall conform to the requirements under other applicable Contract Sections. Temporary and permanent paved and unpaved surface restoration shall conform to the requirements under other applicable Contract Sections.

650.4 Method of Measurement: This work will be measured for payment by the actual number of linear feet of 8-inch ductile iron pipe, complete as shown, specified and directed. The length of pipe to be measured shall be the length of the line after the pipes have been installed, measured or computed along the center line of the pipe from the center line of the main line valves or face of the terminal pipe or fitting, as shown on the Contract Drawings.

Gravel fill from the bottom of the trench to the level 24-inches above the top of the pipe will not be measured for payment, but will be included in the cost of the pipe.

650.5 Basis of Payment: This work will be paid for at the contract unit price per linear foot for "Ductile Iron Pipe (Water Main)" complete and in place. The price shall also include the cost of digging test pits; transporting the materials; clearing, trenching; disposing of excavated materials, removing and disposing of the present water pipes and any appurtenances as needed; furnishing and installing the pipelines complete as shown on plans or as directed, with lacing and harnessing where required, including fittings, bleeders, pressure reducing valves, vaults, bends, restraint, filter fabric, bank gravel, sand, blow off assemblies, gate/butterfly valves, air valves, sterilization fittings, tapping sleeves, tapping gates, RCP sleeve, gate boxes, tees, thrust blocks, anchors, utility identification tape and fire hydrant assemblies; refilling trenches; furnishing the additional materials; temporary and permanent resurfacing; grading; sheeting; bracing; pumping and all incidental work, except as otherwise herein provided for. No claim will be allowed because the number of pipes and joints may be greater than estimated by the Contractor. The price shall also include all material, transportation, labor, including labor required to assist the District during the testing, and equipment necessary to construct the pipelines in accord with the Contract Drawings, the Specifications and the requirements of the Engineer there under.

The cost of all excavation, disposing of excavated material, except that which is suitable for refilling, and furnishing other materials for refilling, unless otherwise specified, will be considered as having been included in the price bid per linear foot of pipeline.

No direct payment will be made for any work done or materials used in making the pipeline tight.

**652.0 PIPE INSULATION (WATER MAIN)**

652.1 General: The Contractor shall furnish and install the required pipe insulation and jacketing to enclose the insulation over pipe, mechanical joints, fittings, expansion joints, etc. as shown on the Contract Drawings, complete as shown, specified or directed, including but not limited to; transporting materials, cleaning and preparing pipe surfaces and furnishing and installing the insulation and jacketing to the specifications and details of the District, except as otherwise herein provided for.

652.2 Materials: Six (6) sets of the manufacturers' literature and/or shop drawings for the materials of this section shall be submitted for approval. The Contractor shall furnish detailed and no work shall be fabricated until they have been approved by the District and Engineer.

Insulation shall be FOAMGLAS® cellular glass insulation manufactured in accordance with ASTM C552, "Standard Specification for Cellular Glass Thermal Insulation", by Pittsburgh Corning Corporation whose quality system for manufacturing, inspecting, and testing of FOAMGLAS® Insulation is certified to meet the requirements of ISO 9002 or approved equal. The FOAMGLAS® Insulation shall be fabricated in half sections wherever possible. For large diameter piping where half sections are not practical, curved sidewall segments are preferred. Wherever possible, the insulation should be factory jacketed with one of the following protective membranes or approved equal:

PITWRAP® Jacketing – a 125 mil thick heat sealed high polymer asphaltic membrane with an integral glass scrim and an integral 1 mil aluminum foil and a thin Mylar film on the surface.

PITWRAP® SS Jacketing - a 70 mil thick self-sealing high polymer asphalt membrane with an integral glass scrim and an aluminized Mylar film on the surface.

PITWRAP® CW Plus Jacketing – a 50 mil thick self sealing modified bituminous membrane consisting of a polymer modified bituminous compound reinforced with a glass fabric and a 1 mil aluminum top film and release paper backing.

Pipe covering protection saddles shall be provided to prevent crushing of insulation at cradle installations. Protection saddles shall be Fig. 654 as manufactured by the PHD Manufacturing, Inc. of Columbiana, Ohio or approved equal.

Mastic shall be PITTCOTE® 300 Finish, an asphalt cutback mastic or approved equal.

Reinforcing Fabric shall be PC® Fabric 79 open mesh polyester fabric with a 6 x 5.5 mesh/inch configuration or approved equal.

Sealant shall be PITSEAL® 444N sealant, a non-setting butyl sealant with a minimum 85% solids content or approved equal.

652.3 Construction Methods: Insulation shall be applied to piping with all joints tightly butted. Joint sealant shall completely fill spaces between sections. Metal bands at the rate of 2 per section shall secure sections to pipe but should not be allowed to crush insulation. Cracked or broken sections shall be replaced. Spaces between sections, mechanical joints and expansion joints shall be packed with a light density fiberglass. Installation of insulation, jacket and finish shall be applied per manufacturers' recommendation.



- 652.4        Method of Measurement: The work for “Pipe Insulation (Water Main)” will be measured for payment by the actual number of linear feet of insulation and jacket installed, complete as shown, specified and directed.
- 652.5        Basis of Payment: This work will be paid for at the Contract unit price per linear foot for “Pipe Insulation (Water Main)” complete in place, which price shall include all transportation, material, labor and equipment necessary to complete the installation in accord with the Contract Drawings, Specifications and the requirements of the Engineer there under. No claim will be allowed because the number of pipes and joints may be greater than estimated by the Contractor.

Proposal of \_\_\_\_\_  
(hereinafter called "Bidder"), organized and existing under the laws of the State of \_\_\_\_\_  
\_\_\_\_\_, doing business as \_\_\_\_\_  
\_\_\_\_\_.

To the Town of Glastonbury (hereinafter called "Town").

In compliance with your Invitation to Bid, the Bidder hereby proposed to furnish materials and/or services as per Bid Number GL-2010-54 **REBID** in strict accordance with the Bid Documents, within the time set forth therein, and at the prices stated below.

By submission of this bid, the Bidder certifies, and in the case of a joint bid each party thereto certifies as to their own organization that this bid has been arrived at independently without consultation, communication, or agreement as to any matter relating to this bid with any other Bidder or with any competitor.

The Bidder acknowledges receipt of the following:

Addendum #1 \_\_\_\_\_

Addendum #2 \_\_\_\_\_

Addendum #3 \_\_\_\_\_

It is the responsibility of the Bidder to check the Town's website for any Addendum before submitting the bid.

**WILLIAMS STREET EAST BRIDGE REHABILITATION  
 BID PROPOSAL**

**BID #GL-2010-54 REBID**

<u>ITEM NO.</u>	<u>DESCRIPTION</u>	<u>QTY.</u>	<u>UNIT PRICE</u>	<u>EXTENSION</u>
1.	<b>Structure Excavation – Earth (Complete)</b> in accordance with Section 102.0 of the Detailed Construction Specifications	210 CY	\$ _____/C.Y.	\$ _____
2.	<b>Protection and Support of Existing Underground CNG Facilities</b> in accordance with Section 103.0 of the Detailed Construction Specifications	Lump Sum	\$ _____/L.S.	\$ _____
3.	<b>Pervious Structure Backfill</b> in accordance with Section 114.0 of the Detailed Construction Specifications	135 CY	\$ _____/C.Y.	\$ _____
4.	<b>Resetting Stone Masonry</b> in accordance with Section 120.0 of the Detailed Construction Specifications	Lump Sum	\$ _____/L.S.	\$ _____
5.	<b>Class ‘A’ Concrete</b> in accordance with Section 125.0 of the Detailed Construction Specifications	8 C.Y.	\$ _____/C.Y.	\$ _____
6.	<b>Deformed Steel Bars – Epoxy Coated</b> in accordance with Section 130.0 of the Detailed Construction Specifications	45 pounds	\$ _____/LB.	\$ _____
7.	<b>Drilling and Grouting Reinforcing Bars</b> in accordance with Section 132.0 of the Detailed Construction Specifications	3 L.F.	\$ _____/L.F.	\$ _____
8.	<b>Debris Shield</b> in accordance with Section 134.0 of the Detailed Construction Specifications	Lump Sum	\$ _____/L.S.	\$ _____
9.	<b>Structural Steel</b> in accordance with Section 135.0 of the Detailed Construction Specifications	3,525 pounds	\$ _____/LB.	\$ _____
10.	<b>Cement Rubble Masonry</b> in accordance with Section 140.0 of the Detailed Construction Specifications	22 C.Y.	\$ _____/C.Y.	\$ _____
11.	<b>Remove and Replace Brick Masonry</b> in accordance with Section 150.0 of the Detailed Construction Specifications	Lump Sum	\$ _____/L.S.	\$ _____
12.	<b>Repointed Masonry</b> in accordance with Section 160.0 of the Detailed Construction Specifications	23 S.Y.	\$ _____/S.Y.	\$ _____
13.	<b>6-inch Underdrain</b> in accordance with Section 210.0 of the Detailed Construction Specifications	111 L.F.	\$ _____/L.F.	\$ _____

**WILLIAMS STREET EAST BRIDGE REHABILITATION  
 BID PROPOSAL**

**BID #GL-2010-54 REBID**

ITEM NO.	DESCRIPTION	QTY.	UNIT PRICE	EXTENSION
14.	<b>Geotextile Subsurface Drainage (Class A)</b> in accordance with Section 215.0 of the Detailed Construction Specifications	103 S.Y.	\$ _____/S.Y.	\$ _____
15.	<b>Impervious Polyethylene Geomembrane Liner</b> in accordance with Section 220.0 of the Detailed Construction Specifications	101 S.Y.	\$ _____/S.Y.	\$ _____
16.	<b>Metal Beam Rail (Type R-B 350) (Weathering Steel)</b> in accordance with Section 230.0 of the Detailed Construction Specifications	31 L.F.	\$ _____/L.F.	\$ _____
17.	<b>R-B Terminal End Section (Weathering Steel)</b> in accordance with Section 230.0 of the Detailed Construction Specifications	1 Each	\$ _____/EA.	\$ _____
18.	<b>R-B End Anchorage Type 1 (Weathering Steel)</b> in accordance with Section 235.0 of the Detailed Construction Specifications	3 Each	\$ _____/EA.	\$ _____
19.	<b>R-B 350 Bridge Attachment Vertical Shaped Parapet (Weathering Steel)</b> in accordance with Section 240.0 of the Detailed Construction Specifications	4 Each	\$ _____/EA.	\$ _____
20.	<b>Removal of Existing Masonry</b> in accordance with Section 290.0 of the Detailed Construction Specifications	10 C.Y.	\$ _____/C.Y.	\$ _____
21.	<b>Ductile Iron Pipe (Water Main)</b> in accordance with Section 650.0 of the Detailed Construction Specifications	44 L.F.	\$ _____/L.F.	\$ _____
22.	<b>Pipe Insulation (Water Main)</b> in accordance with Section 652.0 of the Detailed Construction Specifications	20 L.F.	\$ _____/L.F.	\$ _____

**TOTAL BID AMOUNT:** \$ \_\_\_\_\_

**WRITTEN BID AMOUNT:** \_\_\_\_\_  
 \_\_\_\_\_

**WILLIAMS STREET EAST BRIDGE REHABILITATION  
BID PROPOSAL**

**BID #GL-2010-54 REBID**

**TOWN OF GLASTONBURY  
BID / PROPOSAL**

**DATE ADVERTISED**

**8/3/2010**

**GL #**

**DATE / TIME DUE**

**2010-54 REBID**

**8/24/2010 at 11:00  
A.M.**

**NAME OF PROJECT**

**Williams Street East Bridge Rehabilitation**

It is the responsibility of the Bidder to clearly mark the outside of the bid envelope with the Bid Number, Date and Time of Bid Opening, and it also THE RESPONSIBILITY OF THE BIDDER TO CHECK THE TOWN'S WEBSITE BEFORE SUBMITTING BID FOR ADDENDUMS POSTED PRIOR TO BID OPENING.

**CODE OF ETHICS:**

**I/We have reviewed a copy of the Town of Glastonbury's Code of Ethics and agree to submit a Consultant Acknowledgement Form if I/We are selected. Yes \_\_\_\_\_ No \_\_\_\_\_\***

**\*Bidder is advised that effective August 1, 2003, the Town of Glastonbury cannot consider any bid or proposal where the Bidder has not agreed to the above statement.**

**Respectfully submitted:**

\_\_\_\_\_  
**Type or Print Name of Individual**

\_\_\_\_\_  
**Doing Business as (Trade Name)**

\_\_\_\_\_  
**Signature of Individual**

\_\_\_\_\_  
**Street Address**

\_\_\_\_\_  
**Title**

\_\_\_\_\_  
**City, State, Zip Code**

\_\_\_\_\_  
**Date**

\_\_\_\_\_  
**Telephone Number/Fax Number**

\_\_\_\_\_  
**E-Mail Address**

\_\_\_\_\_  
**SS# or TIN#**

(Seal – If bid is by a Corporation)

Attest

**ATTACHMENT A – PREVAILING WAGE RATE**

Project: Williams Street East Bridge Rehabilitation

**Minimum Rates and Classifications  
for Heavy/Highway Construction**

H 14072

**Connecticut Department of Labor  
Wage and Workplace Standards Division**

By virtue of the authority vested in the Labor Commissioner under provisions of Section 31-53 of the General Statutes of Connecticut, as amended, the following are declared to be the prevailing rates and welfare payments and will apply only where the contract is advertised for bid within 20 days of the date on which the rates are established. Any contractor or subcontractor not obligated by agreement to pay to the welfare and pension fund shall pay this amount to each employee as part of his/her hourly wages.

Project Number: PW-0917 and GL2010-54

Project Town: Glastonbury

FAP Number:

State Number:

Project: Williams Street East Bridge Rehabilitation

**CLASSIFICATION**

**Hourly Rate**

**Benefits**

01) Asbestos/Toxic Waste Removal Laborers: Asbestos removal and encapsulation (except its removal from mechanical systems which are not to be scrapped), toxic waste removers, blasters. \*\*See Laborers Group 7\*\*

1) Boilermaker

\$33.79

34% + 8.96

1a) Bricklayer, Cement Masons, Cement Finishers, Plasterers, Stone Masons

\$32.43

20.54

2) Carpenters, Piledrivermen

\$29.03

18.57

2a) Diver Tenders

\$29.03

18.57

*As of:*

Wednesday, July 28, 2010

Project: Williams Street East Bridge Rehabilitation

3) Divers	\$37.49	18.57
4) Painters: (Bridge Construction) Brush, Roller, Blasting (Sand, Water, etc.), Spray	\$40.25	14.75
4a) Painters: Brush and Roller	\$28.17	14.55
4b) Painters: Spray Only	\$31.17	14.55
4c) Painters: Steel Only	\$30.17	14.55
4d) Painters: Blast and Spray	\$31.17	14.55
4e) Painters: Tanks, Tower and Swing	\$30.17	14.55
5) Electrician (Trade License required: E-1,2 L-5,6 C-5,6 T-1,2 L-1,2 V-1,2,7,8,9)	\$35.40	20.76

*As of:*

Wednesday, July 28, 2010



Project: Williams Street East Bridge Rehabilitation

6) Ironworkers: (Ornamental, Reinforcing, Structural, and Precast Concrete Erection	\$33.00	26.58 + a
---	---------	-----------

7) Plumbers (Trade License required: (P-1,2,6,7,8,9 J-1,2,3,4 SP-1,2) and Pipefitters (Including HVAC Work) (Trade License required: S-1,2,3,4,5,6,7,8 B-1,2,3,4 D-1,2,3,4 G-1, G-2, G-8, G-9)	\$37.62	22.51
--	---------	-------

----LABORERS---- - Last updated 5/10/10

8) Group 1: Laborer (Unskilled), Common or General, acetylene burner, concrete specialist	\$25.00	15.00
---	---------	-------

9) Group 2: Chain saw operators, fence and guard rail erectors, pneumatic tool operators, powdermen, air tool operator	\$25.25	15.00
--	---------	-------

10) Group 3: Pipelayers (Installation of water, storm drainage or sewage lines outside of the building line with P6, P7 license)	\$25.50	15.00
--	---------	-------

11) Group 4: Jackhammer/Pavement breaker (handheld); mason tenders (cement/concrete), catch basin builders, asphalt rakers, air track operators, block pavers and curb setters	\$25.50	15.00
--	---------	-------

12) Group 5: Toxic waste removal (non-mechanical systems)	\$27.00	15.00
---	---------	-------

Project: Williams Street East Bridge Rehabilitation

13) Group 6: Blasters \$26.75 15.00

Group 7: Asbestos Removal, non-mechanical systems (does not include leaded joint pipe) \$26.00 15.00

Group 8: Traffic control signalmen \$16.00 15.00

----LABORERS (TUNNEL CONSTRUCTION, FREE AIR). Shield Drive and Liner Plate Tunnels in Free Air.---- Last updated 5/10/10----

13a) Miners, Motormen, Mucking Machine Operators, Nozzle Men, Grout Men, Shaft & Tunnel Steel & Rodmen, Shield & Erector, Arm Operator, Cable Tenders \$29.44 15.00 + a

13b) Brakemen, Trackmen \$28.58 15.00 + a

----CLEANING, CONCRETE AND CAULKING TUNNEL----Last updated 5/10/10----

14) Concrete Workers, Form Movers, and Strippers \$28.58 15.00 + a

Project: Williams Street East Bridge Rehabilitation

15) Form Erectors	\$28.88	15.00 + a
-------------------	---------	-----------

----ROCK SHAFT LINING, CONCRETE, LINING OF SAME AND  
TUNNEL IN FREE AIR:----Last updated 5/10/10----

16) Brakemen, Trackmen, Tunnel Laborers, Shaft Laborers	\$28.58	15.00 + a
---	---------	-----------

17) Laborers Topside, Cage Tenders, Bellman	\$28.48	15.00 + a
---	---------	-----------

18) Miners	\$29.44	15.00 + a
------------	---------	-----------

----TUNNELS, CAISSON AND CYLINDER WORK IN COMPRESSED  
AIR: ----Last updated 5/10/10----

18a) Blaster	\$35.21	15.00 + a
--------------	---------	-----------

19) Brakemen, Trackmen, Groutman, Laborers, Outside Lock Tender, Gauge Tenders	\$35.04	15.00 + a
---	---------	-----------

Project: Williams Street East Bridge Rehabilitation

20) Change House Attendants, Powder Watchmen, Top on Iron Bolts	\$33.27	15.00 + a
---	---------	-----------

21) Mucking Machine Operator	\$35.75	15.00 + a
------------------------------	---------	-----------

----TRUCK DRIVERS----(\*see note below)

Two axle trucks	\$27.88	14.53 + a
-----------------	---------	-----------

Three axle trucks; two axle ready mix	\$27.98	14.53 + a
---------------------------------------	---------	-----------

Three axle ready mix	\$28.03	14.53 + a
----------------------	---------	-----------

Four axle trucks, heavy duty trailer (up to 40 tons)	\$28.08	14.53 + a
--	---------	-----------

Four axle ready-mix	\$28.13	14.53 + a
---------------------	---------	-----------

Project: Williams Street East Bridge Rehabilitation

Heavy duty trailer (40 tons and over)	\$28.33	14.53 + a
Specialized earth moving equipment other than conventional type on-the road trucks and semi-trailer (including Euclids)	\$28.13	14.53 + a

----POWER EQUIPMENT OPERATORS----

Group 1: Crane handling or erecting structural steel or stone, hoisting engineer (2 drums or over), front end loader (7 cubic yards or over), Work Boat 26 ft. & Over. (Trade License Required)	\$35.05	18.60 + a
Group 2: Cranes (100 ton rate capacity and over); Backhoe/Excavator over 2 cubic yards; Piledriver (\$3.00 premium when operator controls hammer). (Trade License Required)	\$34.73	18.60 + a
Group 3: Excavator; Cranes (under 100 ton rated capacity), Gradall; Master Mechanic; Hoisting Engineer (all types of equipment where a drum and cable are used to hoist or drag material regardless of motive power of operation), Rubber Tire Excavator (Drott-1085 or similar); Grader Operator; Bulldozer Fine Grade (slopes, shaping, laser or GPS, etc.). (Trade License Required)	\$33.99	18.60 + a
Group 4: Trenching Machines; Lighter Derrick; Concrete Finishing Machine; CMI Machine or Similar; Koehring Loader (Skooper)	\$33.60	18.60 + a
Group 5: Specialty Railroad Equipment; Asphalt Paver; Asphalt Spreader; Asphalt Reclaiming Machine; Line Grinder; Concrete Pumps; Drills with Self Contained Power Units; Boring Machine; Post Hole Digger; Auger; Pounder; Well Digger; Milling Machine (over 24" Mandrell)	\$33.01	18.60 + a

Project: Williams Street East Bridge Rehabilitation

Group 5 continued: Side Boom; Combination Hoe and Loader; Directional Driller.	\$33.01	18.60 + a
Group 6: Front End Loader (3 up to 7 cubic yards); Bulldozer (rough grade dozer).	\$32.70	18.60 + a
Group 7: Asphalt Roller; Concrete Saws and Cutters (ride on types); Vermeer Concrete Cutter; Stump Grinder; Scraper; Snooper; Skidder; Milling Machine (24" and Under Mandrel).	\$32.36	18.60 + a
Group 8: Mechanic, Grease Truck Operator, Hydroblaster, Barrier Mover, Power Stone Spreader; Welder; Work Boat under 26 ft.; Transfer Machine.	\$31.96	18.60 + a
Group 9: Front End Loader (under 3 cubic yards), Skid Steer Loader regardless of attachments (Bobcat or Similar); Fork Lift, Power Chipper; Landscape Equipment (including hydroseeder).	\$31.53	18.60 + a
Group 10: Vibratory Hammer, Ice Machine, Diesel and Air Hammer, etc.	\$29.49	18.60 + a
Group 11: Conveyor, Earth Roller; Power Pavement Breaker (whiphammer), Robot Demolition Equipment.	\$29.49	18.60 + a
Group 12: Wellpoint Operator.	\$29.43	18.60 + a

Project: Williams Street East Bridge Rehabilitation

Group 13: Compressor Battery Operator.	\$28.85	18.60 + a
Group 14: Elevator Operator; Tow Motor Operator (Solid Tire No Rough Terrain).	\$27.71	18.60 + a
Group 15: Generator Operator; Compressor Operator; Pump Operator; Welding Machine Operator; Heater Operator.	\$27.30	18.60 + a
Group 16: Maintenance Engineer/Oiler	\$26.65	18.60 + a
Group 17: Portable asphalt plant operator; portable crusher plant operator; portable concrete plant operator.	\$30.96	18.60 + a
Group 18: Power Safety Boat; Vacuum Truck; Zim Mixer; Sweeper; (minimum for any job requiring CDL license).	\$28.54	18.60 + a

\*\*NOTE: SEE BELOW

----LINE CONSTRUCTION----(Railroad Construction and Maintenance)----Last updated 4/17/09----

Project: Williams Street East Bridge Rehabilitation

20) Lineman, Cable Splicer, Dynamite Man	\$35.65	10.70 + 6.25%
21) Heavy Equipment Operator	\$22.09	10.70 + 6.25%
22) Equipment Operator, Tractor Trailer Driver, Material Men	\$30.30	10.70 + 6.25%
23) Driver Groundmen	\$26.74	10.70 + 6.25%
----LINE CONSTRUCTION----Last updated 4/17/09----		
24) Driver Groundmen	\$30.92	6.5% + 9.70
25) Groundmen	\$22.67	6.5% + 6.20
26) Heavy Equipment Operators	\$37.10	6.5% + 10.70

*As of:*

Wednesday, July 28, 2010



Project: Williams Street East Bridge Rehabilitation

27) Linemen, Cable Splicers, Dynamite Men	\$41.22	6.5% + 12.20
---	---------	--------------

28) Material Men, Tractor Trailer Drivers, Equipment Operators	\$35.04	6.5% + 10.45
--	---------	--------------

*As of:*

Wednesday, July 28, 2010

Project: Williams Street East Bridge Rehabilitation

*Welders: Rate for craft to which welding is incidental.*

*\*Note: Hazardous waste removal work receives additional \$1.25 per hour for truck drivers.*

*\*\*Note: Hazardous waste premium \$3.00 per hour over classified rate*

- Crane with 150 ft. boom (including jib) - \$1.50 extra
- Crane with 200 ft. boom (including jib) - \$2.50 extra
- Crane with 250 ft. boom (including jib) - \$5.00 extra
- Crane with 300 ft. boom (including jib) - \$7.00 extra
- Crane with 400 ft. boom (including jib) - \$10.00 extra

All classifications that indicate a percentage of the fringe benefits must be calculated at the percentage rate times the "base hourly rate".

Apprentices duly registered under the Commissioner of Labor's regulations on "Work Training Standards for Apprenticeship and Training Programs" Section 31-51-d-1 to 12, are allowed to be paid the appropriate percentage of the prevailing journeymen hourly base and the full fringe benefit rate, providing the work site ratio shall not be less than one full-time journeyman instructing and supervising the work of each apprentice in a specific trade.

*~~Connecticut General Statute Section 31-55a: Annual Adjustments to wage rates by contractors doing state work ~~*

*The Prevailing wage rates applicable to this project are subject to annual adjustments each July 1st for the duration of the project.*

*Each contractor shall pay the annual adjusted prevailing wage rate that is in effect each July 1st, as posted by the Department of Labor.*

*It is the contractor's responsibility to obtain the annual adjusted prevailing wage rate increases directly from the Department of Labor's website.*

*The annual adjustments will be posted on the Department of Labor's Web page: [www.ct.gov/dol](http://www.ct.gov/dol).*

*The Department of Labor will continue to issue the initial prevailing wage rate schedule to the Contracting Agency for the project.*

*All subsequent annual adjustments will be posted on our Web Site for contractor access.*

**As of:**

Wednesday, July 28, 2010

Project: Williams Street East Bridge Rehabilitation

*Effective October 1, 2005 - Public Act 05-50: any person performing the work of any mechanic, laborer, or worker shall be paid prevailing wage*

All Person who perform work ON SITE must be paid prevailing wage for the appropriate mechanic, laborer, or worker classification.

All certified payrolls must list the hours worked and wages paid to All Persons who perform work ON SITE regardless of their ownership i.e.: (Owners, Corporate Officers, LLC Members, Independent Contractors, et. al)

Reporting and payment of wages is required regardless of any contractual relationship alleged to exist between the contractor and such person.

**~~Unlisted classifications needed for work not included within the scope of the classifications listed may be added after award only as provided in the labor standards contract clause (29 CFR 5.5 (a) (1) (ii)).**

Please direct any questions which you may have pertaining to classification of work and payment of prevailing wages to the Wage and Workplace Standards Division, telephone (860)263-6790.

*As of:*

Wednesday, July 28, 2010

Connecticut Department of Labor  
Wage and Workplace Standards Division  
FOOTNOTES

Please Note: If the “Benefits” listed on the schedule for the following occupations includes a letter(s) (+ a or + a+b for instance), refer to the information below.

Benefits to be paid at the appropriate prevailing wage rate for the listed occupation.

If the “Benefits” section for the occupation lists only a dollar amount, disregard the information below.

**Bricklayers, Cement Masons, Cement Finishers, Concrete Finishers (including caulking),  
Stone Masons**  
(Building Construction) and  
(Residential- Hartford, Middlesex, New Haven, New London and Tolland Counties)

- a. Paid Holiday: Employees shall receive 4 hours for Christmas Eve holiday provided the employee works the regularly scheduled day before and after the holiday. Employers may schedule work on Christmas Eve and employees shall receive pay for actual hours worked in addition to holiday pay.

**Bricklayer (Residential- Fairfield County)**

- a. Paid Holiday: If an employee works on Christmas Eve until noon he shall be paid for 8 hours.

**Electricians**

Fairfield County: West of the Five Mile River in Norwalk

- a. \$2.00 per hour not to exceed \$14.00 per day.

**Elevator Constructors: Mechanics**

- a. Paid Holidays: New Year’s Day, Memorial Day, Independence Day, Labor Day, Veterans’ Day, Thanksgiving Day, Christmas Day, plus the Friday after Thanksgiving.
- b. Vacation: Employer contributes 8% of basic hourly rate for 5 years or more of service or 6% of basic hourly rate for 6 months to 5 years of service as vacation pay credit.

**Glaziers**

- a. Paid Holidays: Labor Day and Christmas Day.

**Power Equipment Operators**

(Heavy and Highway Construction & Building Construction)

- a. Paid Holidays: New Year's Day, Good Friday, Memorial day, Independence Day, Labor Day, Thanksgiving Day and Christmas Day, provided the employee works 3 days during the week in which the holiday falls, if scheduled, and if scheduled, the working day before and the working day after the holiday. Holidays falling on Saturday may be observed on Saturday, or if the employer so elects, on the preceding Friday.

**Ironworkers**

- a. Paid Holiday: Labor Day provided employee has been on the payroll for the 5 consecutive work days prior to Labor Day.

**Laborers (Tunnel Construction)**

- a. Paid Holidays: New Year's Day, Memorial Day, Independence Day, Labor Day, Thanksgiving Day and Christmas Day. No employee shall be eligible for holiday pay when he fails, without cause, to work the regular work day preceding the holiday or the regular work day following the holiday.

**Roofers**

- a. Paid Holidays: July 4<sup>th</sup>, Labor Day, and Christmas Day provided the employee is employed 15 days prior to the holiday.

**Sprinkler Fitters**

- a. Paid Holidays: Memorial Day, July 4th, Labor Day, Thanksgiving Day and Christmas Day, provided the employee has been in the employment of a contractor 20 working days prior to any such paid holiday.

**Truck Drivers**

(Heavy and Highway Construction & Building Construction)

- a. Paid Holidays: New Year's Day, Memorial Day, Independence Day, Labor Day, Thanksgiving Day, Christmas day, and Good Friday, provided the employee has at least 31 calendar days of service and works the last scheduled day before and the first scheduled day after the holiday, unless excused.

# Information Bulletin

## *Occupational Classifications*

The Connecticut Department of Labor has the responsibility to properly determine "job classification" on prevailing wage projects covered under C.G.S. Section 31-53.

*♪ Note: This information is intended to provide a sample of some occupational classifications for guidance purposes only. It is not an all-inclusive list of each occupation's duties. This list is being provided only to highlight some areas where a contractor may be unclear regarding the proper classification.*

**Below are additional clarifications of specific job duties performed for certain classifications:**

### **Asbestos Insulator**

- Handle, install, apply, fabricate, distribute, prepare, alter, repair, or dismantle heat and frost insulation, including penetration and fire stopping work on all penetration fire stop systems.

### **Carpenter**

- Assembly and installation of modular furniture/furniture systems.  
[New] a. Free-standing furniture is not covered. This includes: student chairs, study top desks, book box desks, computer furniture, dictionary stand, atlas stand, wood shelving, two- position information access station, file cabinets, storage cabinets, tables, etc.
- Applies fire stopping materials on fire resistive joint systems only.
- Installation of insulated material of all types whether blown, nailed or attached in other ways to walls, ceilings and floors of buildings.
- Installation of curtain/window walls only where attached to wood or metal studs.

### **Cleaning Laborer**

- The clean up of any construction debris and the general cleaning, including sweeping, wash down, mopping, wiping of the construction facility, washing, polishing, dusting, etc., prior to the issuance of a certificate of occupancy falls under the *Labor classification*.

### **Delivery Personnel (Revised)**

- If delivery of supplies/building materials is to one common point and stockpiled there, prevailing wages are not required. If the delivery personnel are involved in the distribution of the material to multiple locations within the construction site then they would have to be paid prevailing wages for the type of work performed: laborer, equipment operator, electrician, ironworker, plumber, etc.
- An example of this would be where delivery of drywall is made to a building and the delivery personnel distribute the drywall from one "stockpile" location to further sub-locations on each floor. Distribution of material around a construction site is the job of a laborer/tradesman and not a delivery personnel.

### **Electrician**

- Installation or maintenance of telecommunication, LAN wiring or computer equipment.
- Low voltage wiring.

### **Fork Lift Operator**

- Laborers Group 4) Mason Tenders - operates forklift solely to assist a mason to a maximum height of nine (9) feet only.
- Power Equipment Operator Group 9 - operates forklift to assist any trade, and to assist a mason to a height over nine (9) feet.

### **Glaziers**

- Installs light metal sash, head sills, and 2-story aluminum storefronts.
- Installation of aluminum window walls and curtain walls is the "joint work" of the Glaziers and Ironworkers classification which requires either a blended rate or equal composite workforce.

### **Ironworkers**

- Handling, sorting, and installation of reinforcing steel (rebar).
- Installation of aluminum window walls and curtain walls is the "joint work" of the Glaziers and Ironworkers classification which requires either a blended rate or equal composite workforce. Insulated metal and insulated composite panels are still installed by the Ironworker.
- Metal bridge rail (traffic), metal bridge handrail, and decorative security fence installation.

## **Insulator**

- Installing fire stopping systems/materials for "Penetration Firestop Systems": transit to cables, electrical conduits, insulated pipes, sprinkler pipe penetrations, ductwork behind radiation, electrical cable trays, fire rated pipe penetrations, natural polypropylene, HVAC ducts, plumbing bare metal, telephone and communication wires, and boiler room ceilings. Past practice using the applicable licensed trades, Plumber, Sheet Metal, Sprinkler Fitter, and Electrician, is not inconsistent with the Insulator classification and would be permitted.

## **Lead Paint Removal**

- Painter Rate
  1. Removal of lead paint from bridges.
  2. Removal of lead paint as preparation of any surface to be repainted.
  3. Where removal is on a Demolition project prior to reconstruction.
- Laborer Rate
  1. Removal of lead paint from any surface NOT to be repainted.
  2. Where removal is on a *TOTAL* Demolition project only.

## **Roofers**

- Preparation of surface, tear-off and/or removal of any type of roofing, and/or clean-up of any areas where a roof is to be relaid.

## **Sheet Metal Worker**

- Fabrication, handling, assembling, erecting, altering, repairing, etc. of coated metal material panels and composite metal material panels when used on building exteriors and interiors as soffits, fascia, louvers, partitions, wall panel siding, canopies, cornice, column covers, awnings, beam covers, cladding, sun shades, lighting troughs, spires, ornamental roofing, metal ceilings, mansards, copings, ornamental and ventilation hoods, vertical and horizontal siding panels, trim, etc. The sheet metal classification also applies to the vast variety of coated metal material panels and composite metal material panels that have evolved over the years as an alternative to conventional ferrous and non-ferrous metals like steel, iron, tin, copper, brass, bronze, aluminum, etc. Insulated metal and insulated composite panels are still installed by the Iron Worker. Fabrication, handling, assembling, erecting, altering, repairing, etc. of architectural metal roof, standing seam roof, composite metal roof, metal and composite bathroom/toilet partitions, aluminum gutters, metal and composite lockers and shelving, kitchen equipment, and walk-in coolers.



## Truck Drivers

- Truck Drivers delivering asphalt are covered under prevailing wage while on the site and directly involved in the paving operation.
- Material men and deliverymen are not covered under prevailing wage as long as they are not directly involved in the construction process. If, they unload the material, they would then be covered by prevailing wage for the classification they are performing work in: laborer, equipment operator, etc.
- Hauling material off site is not covered provided they are not dumping it at a location outlined above.
- Driving a truck on site and moving equipment or materials on site would be considered covered work, as this is part of the construction process.

 Any questions regarding the proper classification should be directed to the Contract Compliance Unit, Wage and Workplace Standards Division, Connecticut Department of Labor, 200 Folly Brook Blvd, Wethersfield, CT 06 109 at (860) 263-6543.

## ~NOTICE~

### TO ALL CONTRACTING AGENCIES

Please be advised that Connecticut General Statutes Section 31-53, requires the contracting agency to certify to the Department of Labor, the total dollar amount of work to be done in connection with such public works project, regardless of whether such project consists of one or more contracts.

Please find the attached “Contracting Agency Certification Form” to be completed and returned to the Department of Labor, Wage and Workplace Standards Division, Public Contract Compliance Unit.

 Inquiries can be directed to (860)263-6543.

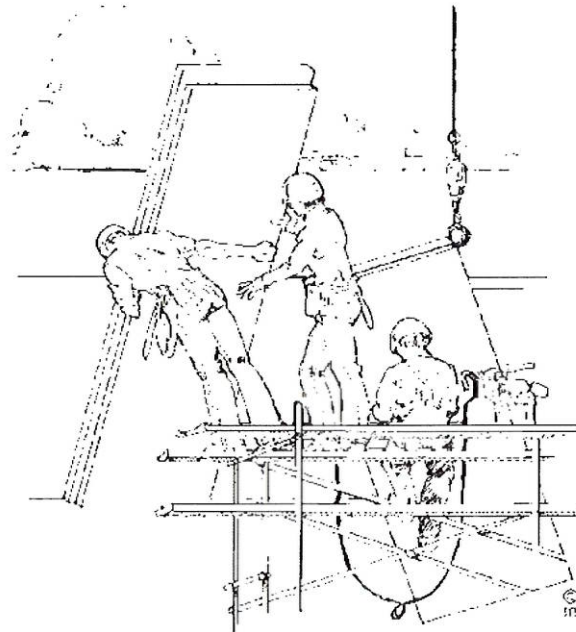

CONNECTICUT DEPARTMENT OF LABOR  
WAGE AND WORKPLACE STANDARDS DIVISION  
CONTRACT COMPLIANCE UNIT

*CONTRACTING AGENCY CERTIFICATION FORM*

I, \_\_\_\_\_, acting in my official capacity as \_\_\_\_\_,  
authorized representative title

for \_\_\_\_\_, located at \_\_\_\_\_,  
contracting agency address

do hereby certify that the total dollar amount of work to be done in connection with

\_\_\_\_\_, located at \_\_\_\_\_,  
project name and number address

shall be \$ \_\_\_\_\_, which includes all work, regardless of whether such project  
consists of one or more contracts.

*CONTRACTOR INFORMATION*

Name: \_\_\_\_\_

Address: \_\_\_\_\_

Authorized Representative: \_\_\_\_\_

Approximate Starting Date: \_\_\_\_\_

Approximate Completion Date: \_\_\_\_\_

\_\_\_\_\_  
Signature

\_\_\_\_\_  
Date

Return To: Connecticut Department of Labor  
Wage & Workplace Standards Division  
Contract Compliance Unit  
200 Folly Brook Blvd.  
Wethersfield, CT 06109

Date Issued: \_\_\_\_\_

CONNECTICUT DEPARTMENT OF LABOR  
WAGE AND WORKPLACE STANDARDS DIVISION

**CONTRACTORS WAGE CERTIFICATION FORM**

I, \_\_\_\_\_ of \_\_\_\_\_  
Officer, Owner, Authorized Rep. Company Name

do hereby certify that the \_\_\_\_\_  
Company Name  
\_\_\_\_\_  
Street  
\_\_\_\_\_  
City

and all of its subcontractors will pay all workers on the  
\_\_\_\_\_  
Project Name and Number  
\_\_\_\_\_  
Street and City

the wages as listed in the schedule of prevailing rates required for such project (a copy of which is attached hereto).

\_\_\_\_\_  
Signed

Subscribed and sworn to before me this \_\_\_\_\_ day of \_\_\_\_\_, \_\_\_\_\_.

\_\_\_\_\_  
Notary Public

Return to:

Connecticut Department of Labor  
Wage & Workplace Standards Division  
200 Folly Brook Blvd.  
Wethersfield, CT 06109

Rate Schedule Issued (Date): \_\_\_\_\_

# **Informational Bulletin**

## **THE 10-HOUR OSHA CONSTRUCTION SAFETY AND HEALTH COURSE**

(applicable to public building contracts entered into *on or after July 1, 2007*, where the total cost of all work to be performed is at least \$100,000)

- (1) This requirement was created by Public Act No. 06-175, which is codified in Section 31-53b of the Connecticut General Statutes (pertaining to the prevailing wage statutes);
- (2) The course is required for public building construction contracts (projects funded in whole or in part by the state or any political subdivision of the state) entered into on or after July 1, 2007;
- (3) It is required of private employees (not state or municipal employees) and apprentices who perform manual labor for a general contractor or subcontractor on a public building project where the total cost of all work to be performed is at least \$100,000;
- (4) The ten-hour construction course pertains to the ten-hour Outreach Course conducted in accordance with federal OSHA Training Institute standards, and, for telecommunications workers, a ten-hour training course conducted in accordance with federal OSHA standard, 29 CFR 1910.268;
- (5) The internet website for the federal OSHA Training Institute is [http://www.osha.gov/fso/ote/training/edcenters/fact\\_sheet.html](http://www.osha.gov/fso/ote/training/edcenters/fact_sheet.html);
- (6) The statutory language leaves it to the contractor and its employees to determine who pays for the cost of the ten-hour Outreach Course;
- (7) Within 30 days of receiving a contract award, a general contractor must furnish proof to the Labor Commissioner that all employees and apprentices performing manual labor on the project will have completed such a course;
- (8) Proof of completion may be demonstrated through either: (a) the presentation of a *bona fide* student course completion card issued by the federal OSHA Training Institute; *or* (2) the presentation of documentation provided to an employee by a trainer certified by the Institute pending the actual issuance of the completion card;
- (9) Any card with an issuance date more than 5 years prior to the commencement date of the construction project shall not constitute proof of compliance;

- (10) Each employer shall affix a copy of the construction safety course completion card to the certified payroll submitted to the contracting agency in accordance with Conn. Gen. Stat. § 31-53(f) on which such employee's name first appears;
- (11) Any employee found to be in non-compliance shall be subject to removal from the worksite if such employee does not provide satisfactory proof of course completion to the Labor Commissioner by the fifteenth day after the date the employee is determined to be in noncompliance;
- (12) Any such employee who is determined to be in noncompliance may continue to work on a public building construction project for a maximum of fourteen consecutive calendar days while bringing his or her status into compliance;
- (13) The Labor Commissioner may make complaint to the prosecuting authorities regarding any employer or agent of the employer, or officer or agent of the corporation who files a false certified payroll with respect to the status of an employee who is performing manual labor on a public building construction project;
- (14) The statute provides the minimum standards required for the completion of a safety course by manual laborers on public construction contracts; any contractor can exceed these minimum requirements; and
- (15) Regulations clarifying the statute are currently in the regulatory process, and shall be posted on the CTDOL website as soon as they are adopted in final form.
- (16) Any questions regarding this statute may be directed to the Wage and Workplace Standards Division of the Connecticut Labor Department via the internet website of <http://www.ctdol.state.ct.us/wgwkstnd/wgemenu.htm>; or by telephone at (860)263-6790.

**THE ABOVE INFORMATION IS PROVIDED EXCLUSIVELY AS AN EDUCATIONAL RESOURCE, AND IS NOT INTENDED AS A SUBSTITUTE FOR LEGAL INTERPRETATIONS WHICH MAY ULTIMATELY ARISE CONCERNING THE CONSTRUCTION OF THE STATUTE OR THE REGULATIONS.**

**Sec. 31-53b. Construction safety and health course. New miner training program. Proof of completion required for mechanics, laborers and workers on public works projects. Enforcement. Regulations. Exceptions.**

(a) Each contract for a public works project entered into on or after July 1, 2009, by the state or any of its agents, or by any political subdivision of the state or any of its agents, described in subsection (g) of section 31-53, shall contain a provision requiring that each contractor furnish proof with the weekly certified payroll form for the first week each employee begins work on such project that any person performing the work of a mechanic, laborer or worker pursuant to the classifications of labor under section 31-53 on such public works project, pursuant to such contract, has completed a course of at least ten hours in duration in construction safety and health approved by the federal Occupational Safety and Health Administration or, has completed a new miner training program approved by the Federal Mine Safety and Health Administration in accordance with 30 CFR 48 or, in the case of telecommunications employees, has completed at least ten hours of training in accordance with 29 CFR 1910.268.

(b) Any person required to complete a course or program under subsection (a) of this section who has not completed the course or program shall be subject to removal from the worksite if the person does not provide documentation of having completed such course or program by the fifteenth day after the date the person is found to be in noncompliance. The Labor Commissioner or said commissioner's designee shall enforce this section.

(c) Not later than January 1, 2009, the Labor Commissioner shall adopt regulations, in accordance with the provisions of chapter 54, to implement the provisions of subsections (a) and (b) of this section. Such regulations shall require that the ten-hour construction safety and health courses required under subsection (a) of this section be conducted in accordance with federal Occupational Safety and Health Administration Training Institute standards, or in accordance with Federal Mine Safety and Health Administration Standards or in accordance with 29 CFR 1910.268, as appropriate. The Labor Commissioner shall accept as sufficient proof of compliance with the provisions of subsection (a) or (b) of this section a student course completion card issued by the federal Occupational Safety and Health Administration Training Institute, or such other proof of compliance said commissioner deems appropriate, dated no earlier than five years before the commencement date of such public works project.

(d) This section shall not apply to employees of public service companies, as defined in section 16-1, or drivers of commercial motor vehicles driving the vehicle on the public works project and delivering or picking up cargo from public works projects provided they perform no labor relating to the project other than the loading and unloading of their cargo.

(P.A. 06-175, S. 1; P.A. 08-83, S. 1.)

History: P.A. 08-83 amended Subsec. (a) by making provisions applicable to public works project contracts entered into on or after July 1, 2009, replacing provision re total cost of work with reference to Sec. 31-53(g), requiring proof in certified payroll form that new mechanic, laborer or worker has completed a 10-hour or more construction safety course and adding provision re new miner training program, amended Subsec. (b) by substituting "person" for "employee" and adding "or program", amended Subsec. (c) by adding "or in accordance with Federal Mine

Safety and Health Administration Standards" and setting new deadline of January 1, 2009, deleted former Subsec. (d) re "public building", added new Subsec. (d) re exemptions for public service company employees and delivery drivers who perform no labor other than delivery and made conforming and technical changes, effective January 1, 2009.



November 29, 2006

**Notice**  
**To All Mason Contractors and Interested Parties**  
**Regarding Construction Pursuant to Section 31-53 of the**  
**Connecticut General Statutes (Prevailing Wage)**

The Connecticut Labor Department Wage and Workplace Standards Division is empowered to enforce the prevailing wage rates on projects covered by the above referenced statute.

Over the past few years the Division has withheld enforcement of the rate in effect for workers who operate a forklift on a prevailing wage rate project due to a potential jurisdictional dispute.

The rate listed in the schedules and in our Occupational Bulletin (see enclosed) has been as follows:

**Forklift Operator:**

- **Laborers (Group 4) Mason Tenders** - operates forklift solely to assist a mason to a maximum height of nine feet only.
- **Power Equipment Operator (Group 9)** - operates forklift to assist any trade and to assist a mason to a height over nine feet.

The U.S. Labor Department conducted a survey of rates in Connecticut but it has not been published and the rate in effect remains as outlined in the above Occupational Bulletin.

*Since this is a classification matter and not one of jurisdiction, effective January 1, 2007 the Connecticut Labor Department will enforce the rate on each schedule in accordance with our statutory authority.*

Your cooperation in filing appropriate and accurate certified payrolls is appreciated.

# Statute 31-55a

Last Updated: April 22, 2010

You are here: [DOL Web Site](#) » [Wage and Workplace Standards](#) » Statute 31-55a

## - Special Notice -

To All State and Political Subdivisions, Their Agents, and Contractors

**Connecticut General Statute 31-55a - Annual adjustments to wage rates by contractors doing state work.**

*Each contractor that is awarded a contract on or after October 1, 2002, for (1) the construction of a state highway or bridge that falls under the provisions of section 31-54 of the general statutes, or (2) the construction, remodeling, refinishing, refurbishing, rehabilitation, alteration or repair of any public works project that falls under the provisions of section 31-53 of the general statutes shall contact the Labor Commissioner on or before July first of each year, for the duration of such contract, to ascertain the prevailing rate of wages on an hourly basis and the amount of payment or contributions paid or payable on behalf of each mechanic, laborer or worker employed upon the work contracted to be done, and shall make any necessary adjustments to such prevailing rate of wages and such payment or contributions paid or payable on behalf of each such employee, effective each July first.*

- The prevailing wage rates applicable to any contract or subcontract awarded on or after October 1, 2002 are subject to annual adjustments each July 1st for the duration of any project which was originally advertised for bids on or after October 1, 2002.
- Each contractor affected by the above requirement shall pay the annual adjusted prevailing wage rate that is in effect each July 1st, as posted by the Department of Labor.
- It is the **contractor's** responsibility to obtain the annual adjusted prevailing wage rate increases directly from the Department of Labor's Web Site. The annual adjustments will be posted on the Department of Labor Web page: [www.ctdol.state.ct.us](http://www.ctdol.state.ct.us). For those without internet access, please contact the division listed below.
- The Department of Labor will continue to issue the initial prevailing wage rate schedule to the Contracting Agency for the project. All subsequent annual adjustments will be posted on our Web Site for contractor access.

**Any questions should be directed to the Contract Compliance Unit, Wage and Workplace Standards Division, Connecticut Department of Labor, 200 Folly Brook Blvd., Wethersfield, CT 06109 at (860)263-6790.**

←-- [Workplace Laws](#)

Published by the Connecticut Department of Labor, Project Management Office

**ATTACHMENT B – CNG GAS MAIN PROTECTION SPECIFICATIONS**

**CNG GENERAL PROVISIONS FOR CONTRACTORS  
WHEN EXCAVATING OVER CAST IRON GAS MAINS**

1. Vibratory rollers shall not be used on subbase materials in the vicinity of cast iron mains closer than the distance equal to the width of the roller drum from the axis of the pipe. Static-type rollers are allowed. Once subbase materials have been placed to grade, vibratory rollers are permitted for installing bituminous pavement.
2. When excavating to subgrade, the use of heavy duty bulldozers, scrapers, or other types of heavy earth-moving equipment are not allowed over cast iron gas mains. This type of equipment is limited to within 18 inches of cast iron pipe as measured from its o.d. Small lightweight dozers or tractor payload type equipment is permitted.
3. When excavating to subgrade, contractors must not allow use of heavy equipment to traverse across or over the cast iron gas main facility until the first course of base material has been installed. Compaction of the subbase material directly over the facility must be completed in the prescribed lifts without the use of heavy-duty impactors.
4. Hand probing to locate gas mains and services is required by Public Act 87-71. It is required that this procedure be practiced by all excavators prior to performing any excavation over the gas facilities. Especially susceptible to damage from road excavation are gas services and the hubs or flanges of cast iron gas mains.
5. When breaking roadway concrete, the use of a "headache ball" and impactors is not allowed.
6. Contractors are required to maintain the markout that the CNG representative has provided. Offset markers are permissible provided they are placed in an area where they are not covered or in any way encumbered from view. The contractor must maintain these marks for the duration of his work in that area.
7. When excavating a trench resulting in the crossing of a cast iron gas facility, exposure or undermining must be kept to a minimum. Contractors are responsible for providing temporary and permanent supports in these areas. Replacement of the cast iron facility at the contractor's expense can be avoided if exposure is limited as outlined in CNG Company Policy 480.01 (enclosed).
8. When an excavation parallels a cast iron facility, conflicts resulting in the replacement of the cast iron pipe can be avoided by prescribing to CNG Company Policy 930.01 (enclosed).
9. Contractors are required by State law to telephone "Call Before You Dig" prior to performing actual excavation, blasting, or demolition. The notifications to "Call Before You Dig" should be made at least 48 hours in advance.
10. When a contractor anticipates blasting to be necessary, the requirements of CNG's Blasting Policy 482.01 must be upheld (enclosed).

**CONNECTICUT NATURAL GAS CORPORATION**  
**DEPARTMENTAL PROCEDURE (480.01)**  
**PROTECTION/REPLACEMENT OF EXPOSED GAS FACILITIES**

**PURPOSE**

This procedure establishes Corporate policy for the protection/replacement of gas facilities when exposed.

The practice of the Corporation is to adhere to the prescriptions of appropriate sections of Title 49 of the Code of Federal Regulations, Part 192.614. Any contractor, utility company crew, builder, or excavator must adhere to the regulations.

**PROCEDURE**

**I. DEFINITIONS**

- A. Excavation - An operation for the purpose of movement or removal of earth, rock, or other materials in or on the ground, or otherwise disturbing the subsurface of the earth, by the use of powered or mechanized equipment. This includes, but is not limited to, digging, pile driving, augering, backfilling, test boring, drilling, grading, plowing-in, hammering, pulling-in, trenching, and tunneling.
- B. Damage - Includes, but is not limited to, the weakening of structure or support, penetration or destruction of the protective coating, housing, or the severance, partial or complete, of gas facilities.
- C. Gas Facility - All physical facilities which house or move gas for transportation and distribution including pipe, valves, and other appurtenances attached to the pipe.

**II. NOTIFICATION**

- A. A copy of this procedure is given to all agencies requesting review of their proposed construction designs.
- B. Upon receipt of outside agencies' plans, maps, and correspondence, Engineering Services reviews the project relative to the Corporation's facilities and responds to the requesting party.
- C. The excavator notifies "Call Before You Dig" (CBYD) as prescribed by Connecticut State Law, Section 16-345 of Public Act 87-71.
- D. Once excavation is started, the construction site supervisors are responsible for visiting the excavation site as outlined in Procedure #929.01 - "Monitoring of CNG Gas Facilities."

**CONNECTICUT NATURAL GAS CORPORATION**  
**DEPARTMENTAL PROCEDURE (480.01)**  
**PROTECTION/REPLACEMENT OF EXPOSED GAS FACILITIES**

III. GUIDELINES

A. General

1. The support for the gas facility either by strapping (see EXHIBITS I and III) or wooden vertical supports (see EXHIBIT II) is installed in a manner that the pipe does not move when the soil is removed from under the pipe and that undue stress is not imposed at fittings, valves, and other accessories on the pipe.
2. Trench shoring practices are not affected by the requirements outlined in this procedure.
3. An excavator is responsible for any damages that he/she inflicts upon the Corporation's facilities.
4. If the excavator/contractor is to be billed for damages or a replacement, the Distribution Supervisor documents, takes photographs of the affected facility, and immediately sends a letter (Exhibit IV) to the excavator/contractor stating that a bill will be forthcoming.
5. Any conflicts between CNG or the excavator/contractor regarding the billing for repair of the damage or the possible replacement are resolved by a Distribution Manager.

B. Crossings

1. Temporary Support - Cast Iron, Steel, Plastic

EXHIBIT I is a drawing which depicts a temporary support for a gas main that crosses a trench at any angle with an exposed pipe length of greater than six feet for cast iron or ten feet for plastic or steel (see 2b).

2. Permanent Support - Cast Iron

- a. When cast iron pipe crossing exposure is six feet or less in length, one permanent pipe support is required (see EXHIBIT II).
- b. When cast iron pipe is six inches or less in diameter and crossing exceeds six feet in length, the pipe is replaced. When this condition exists, the replacement consists of the length of exposure plus a minimum of four feet measured perpendicular from the trench wall to the pipe. The removal and replacement expense is borne by the excavator/contractor.

**CONNECTICUT NATURAL GAS CORPORATION**

**DEPARTMENTAL PROCEDURE (480.01)**

**PROTECTION/REPLACEMENT OF EXPOSED GAS FACILITIES**

- c. When cast iron pipe is greater than six inches in diameter and is crossed and exceeds six feet in length, two or more permanent pipe supports are required.
- d. When cast iron pipe is greater than six inches in diameter and is crossed and the exposure exceeds 12 feet in length, it is considered for possible replacement depending on site conditions.

3. Permanent Support - Steel, Plastic

A firm foundation of properly compacted backfill is the only permanent support required for plastic or steel pipe.

C. Parallel Excavation

1. Temporary Support - Cast Iron, Steel, Plastic

- a. The EXHIBIT III drawing depicts a type of temporary support for a gas main that is exposed or undermined by a parallel excavation.
- b. The policy of the Company is to replace the cast iron pipe at the excavator's/contractor's expense.
  - 1) If the relocation is not possible at the start of the project, temporary supporting may be permitted by CNG after consideration is given to the type of pipe, length of exposed pipe, service lines, and other pertinent facts.
  - 2) When temporary support is allowed, it should be done in a manner similar to EXHIBIT III. After the completion of the project, the replacement of a facility is scheduled to be replaced in accordance with Procedure #930.01 - "Replacement of Cast Iron Pipe."

Date: 3/22/07

**CONNECTICUT NATURAL GAS CORPORATION**

**DEPARTMENTAL PROCEDURE (480.01)**

**PROTECTION/REPLACEMENT OF EXPOSED GAS FACILITIES**

2. Permanent Support - Cast Iron
  - a. After the excavation and before backfilling, if the length of exposure of a cast iron main is less than six feet, the main must be permanently supported as shown in EXHIBIT III.
  - b. If the length of exposure is greater than six feet, the pipe is replaced in compliance with Departmental Procedure #930.01. The cost of this replacement will be borne by the excavator/contractor.

---

Approved:

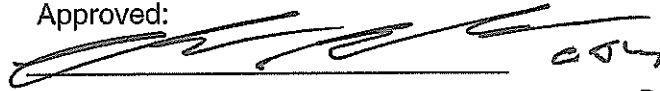

Regional Director – CNG Field Operations

3/22/07



# EXHIBIT I

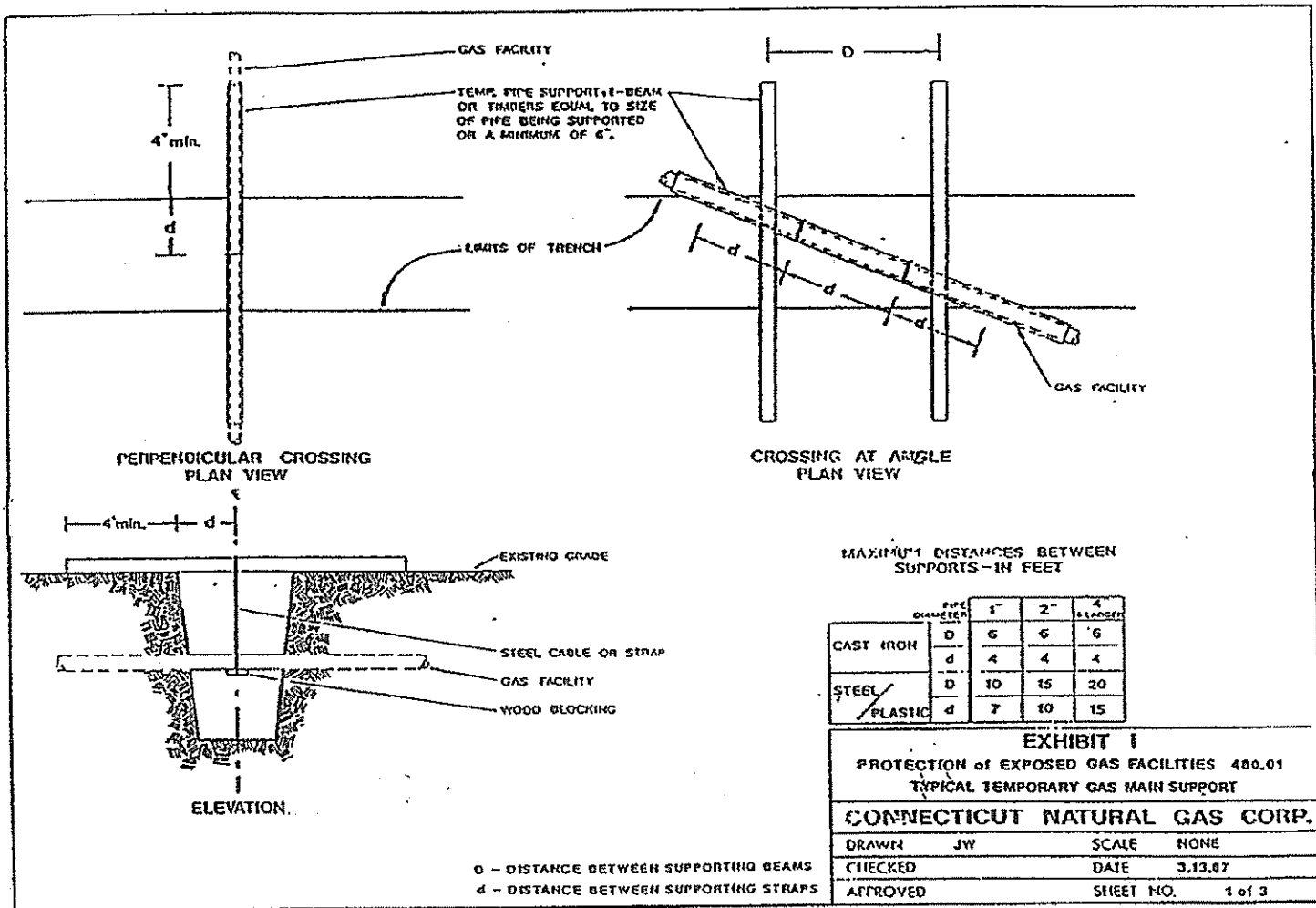
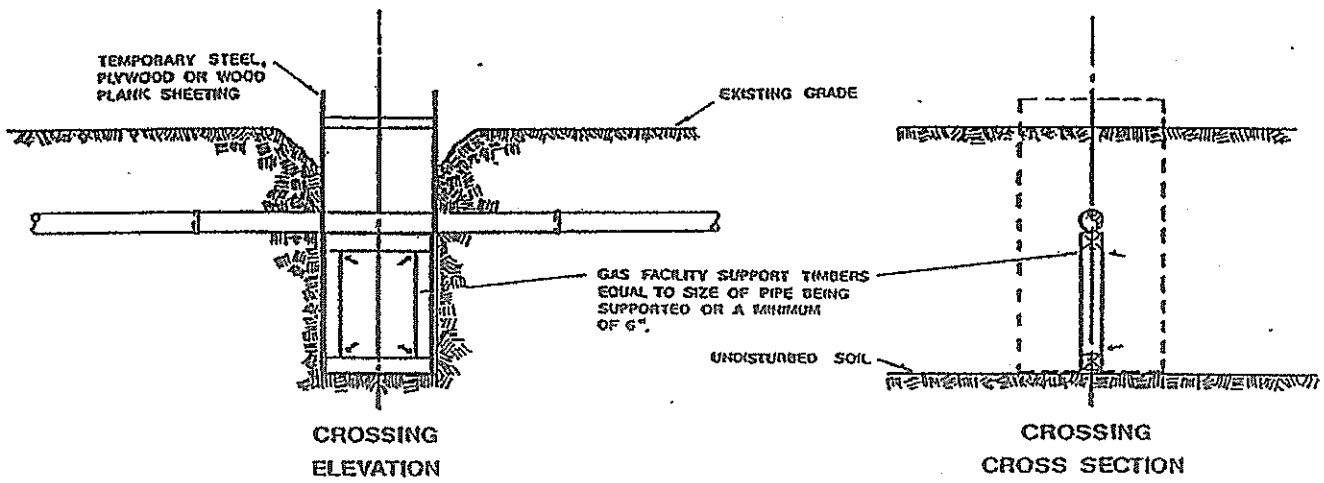

EXHIBIT II



WOOD WEDGES AS REQUIRED

<b>EXHIBIT II</b>			
PROTECTION of EXPOSED GAS FACILITIES 480.01			
TYPICAL PERMANENT CAST IRON GAS MAIN SUPPORT			
<b>CONNECTICUT NATURAL GAS CORP.</b>			
DRAWN	JW	SCALE	NONE
CHECKED		DATE	3.13.87
APPROVED		SHEET NO.	2 of 3

# EXHIBIT III

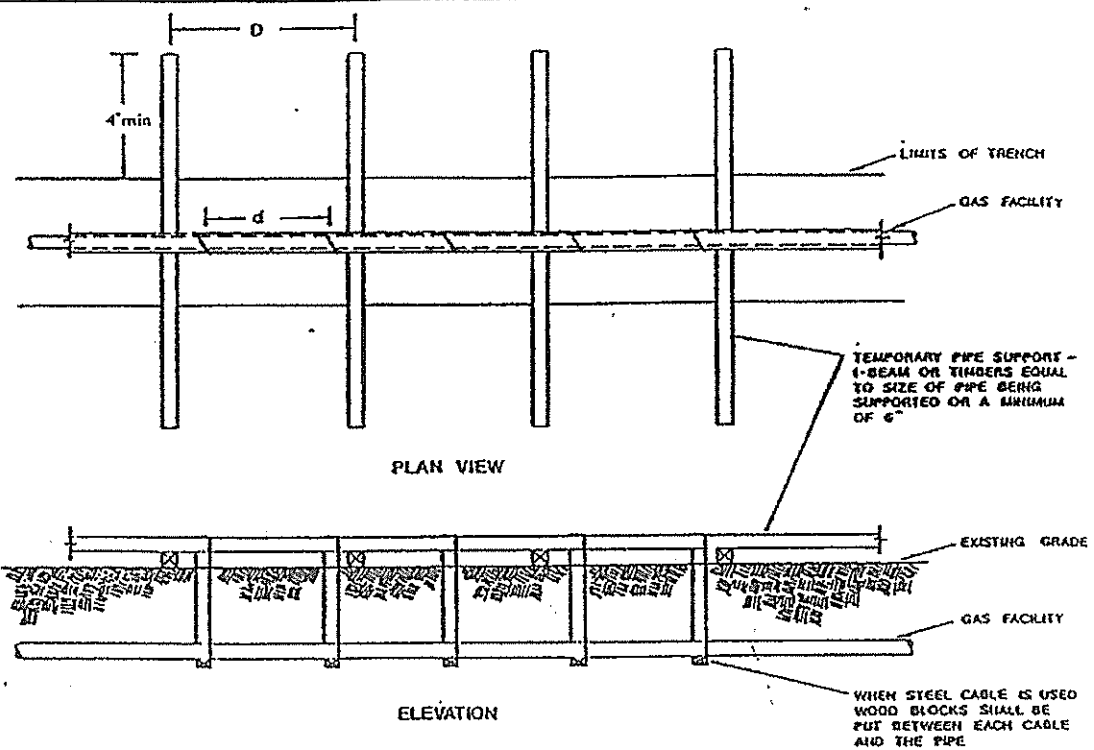

MAXIMUM DISTANCES BETWEEN SUPPORTS - IN FEET

	PIPE DIAMETER	1"	2"	4"
		1"	2"	4"
CAST IRON	D	6	6	6
	d	4	4	4
STEEL / PLASTIC	D	10	15	20
	d	7	10	15

D - DISTANCE BETWEEN SUPPORTING BEAMS  
d - DISTANCE BETWEEN SUPPORTING STRAPS

<b>EXHIBIT III</b>		
PROTECTION OF EXPOSED GAS FACILITIES 480.01		
TYPICAL TEMPORARY GAS MAIN SUPPORT/PARALLEL EXCAVATIONS		
<b>CONNECTICUT NATURAL GAS CORP.</b>		
DRAWN J.J.W.	SCALE	NONE
CHECKED	DATE	3.13.87
APPROVED	SHEET NO.	3 of 3

Date: 3/22/07

**CONNECTICUT NATURAL GAS CORPORATION**

**DEPARTMENTAL PROCEDURE (480.01)**

**PROTECTION/REPLACEMENT OF EXPOSED GAS FACILITIES**

Excavator's Name  
Excavator's Address  
City, State, Zip

**Exhibit IV**

Re:

Gentlemen:

Connecticut Natural Gas Construction Site Inspector, \_\_\_\_\_, states that as a result of your excavating operations on \_\_\_\_\_, approximately \_\_\_\_\_ feet of \_\_\_\_\_ inch cast iron pipe was exposed and/or undermined.

It is the responsibility of the excavator to exercise reasonable care in accordance with the State of Connecticut Public Act 87-71, Section 16-345-4, Responsibility of Excavators:

("a") [V] (5) Exercise reasonable care when working in proximity to the under-ground facilities of any public utility. REASONABLE CARE SHALL INCLUDE, WITHOUT LIMITATION, THE USE OF CONSTRUCTION METHODS APPROPRIATE TO ENSURE THE INTEGRITY OF EXISTING UTILITY FACILITIES AND THEIR TEMPORARY AND PERMANENT SUPPORT INCLUDING BUT NOT LIMITED TO ADEQUATE AND PROPER SHORING AND PROPER BACKFILL METHODS AND TECHNIQUES; THE SELECTION OF EQUIPMENT AND EXPLOSIVES CAPABLE OF PERFORMING THE WORK WITH THE MINIMUM REASONABLE LIKELIHOOD OF DISTURBANCE TO UNDERGROUND FACILITIES; ADEQUATE SUPERVISORY PERSONNEL TO ENSURE PROPER ACTIONS; PROPER UNDERSTANDING BY THE PERSONNEL ON THE JOB SITE OF THE AUTHORITY OF ALL PARTIES INVOLVED IN THE ACTIVITY SO THAT PROMPT ACTION CAN BE TAKEN IN THE EVENT OF UNANTICIPATED CONTACT WITH UNDERGROUND FACILITIES; ADEQUATE TRAINING OF EMPLOYEES IN EXECUTING THEIR ASSIGNMENTS TO ENSURE PROTECTION OF UTILITY FACILITIES AND THE PUBLIC; MAINTAINING NECESSARY LIAISON WITH OWNERS OF UNDERGROUND FACILITIES; SPONSORING PREPLANNING AND PRECONSTRUCTION MEETINGS AS NECESSARY AND COMPLYING WITH ALL APPLICABLE LAWS AND REGULATIONS."

The cast iron pipe appears to have been undermined to an extent that jeopardizes the integrity of the facility. As a result, replacement of the facility in the immediate vicinity of excavation may be necessary. If replacement is necessary, a bill for the replacement will be submitted to you in the near future once the work is complete.

If you have any questions regarding this matter, please contact me.

Very truly yours,

Construction Site Inspector

Refer to Procedure Memorandum #480.01

**ATTACHMENT C - CONSTRUCTION PLANS**