

TOWN OF GLASTONBURY

INVITATION TO BID

<u>BID #</u>	<u>ITEM</u>	<u>DATE &amp; TIME REQUIRED</u>
GL-2024-26	Minnechaug Golf Course Netting Project	March 21, 2024 at 11:00 A.M.

The Town of Glastonbury will receive on-line Bids for the installation of a new protective netting system at the Minnechaug Golf Course located at 16 Fairway Crossing Glastonbury, CT 06033.

Bidders wishing to submit a bid proposal for this solicitation are directed to respond online through a secure e-Procurement portal. Responses can be submitted at the following link:

<https://glastonburyct.bonfirehub.com/> under the bid title “*GL-2024-26 Minnechaug Golf Course Netting Project*”. All bids will be publicly opened and read aloud. **No late bids will be accepted.**

This Invitation to Bid, Instructions to Bidders, Specifications and other Bidding Documents (as defined in the Instruction to Bidders) are available for viewing and downloading on the Town of Glastonbury website [www.glastonburyct.gov](http://www.glastonburyct.gov) at no cost.

The Town of Glastonbury is An Affirmative Action/Equal Opportunity Employer. Minority/Women’s Business Enterprises are encouraged to bid.

**The Town reserves the right to amend or withdraw this Invitation to Bid for any reason, to accept or reject any or all Bids, to waive any informalities or non-material deficiencies in any Bid, and to make such award (or make no award) of a contract in connection with this Invitation to Bid all as determined by the Town, in its discretion, to be in the best interest of the Town. A Bid may be rejected for irregularities of any kind, including without limitation, alteration of form, additions not called for, conditional proposals, and incomplete Bids. A Bid may also be rejected if, in the opinion of the Town, the Bid does not meet the standard of quality established by the Bidding Documents. Any or all Bids may be rejected if there is any reason to believe that collusion exists among two or more Bidders. The foregoing provisions are for illustrative purposes and shall in no way limit the right of the Town to reject any and all Bids, in whole or in part.**

Gina J. Consiglio  
Purchasing Agent

**TABLE OF CONTENTS**

**SECTION/PAGE**

Information for Bidders

IB 1-3

Detailed Specifications

DS 1-5

Insurance Requirements

IR 1

Bid Proposal

BP 1-2

Drawings

Attachment A

Bid Bond

Attachment B

1. Bidders submitting a response for this solicitation are directed to respond online through a secure e-Procurement portal. Bids can be submitted at the following link: <https://glastonburyct.bonfirehub.com/> under the bid title “*GL-2024-26 Minnechaug Golf Course Netting Project*”. Bidders will be required to create a profile before submitting their bid. Step-by-step instructions on how to register as a vendor are available at this website:

<https://vendorsupport.gobonfire.com/hc/en-us/articles/15646869029783-Vendor-Registration>

Bidders will be required to upload their bid response in **one consolidated pdf document** in the following file located in the bid portal:

- Bid Response & Related Documents

2. Whenever it is deemed to be in the best interest of the Town, The Town Manager, Purchasing Agent or designated representative shall waive informalities in any and all bids. The right is reserved to reject any bid, or any part of any bid, when such action is deemed to be in the best interest of the Town of Glastonbury.
3. The basis for the award will be based on the lowest total bid price from a qualified, responsible and responsive Bidder.
4. Bids will be carefully evaluated as to conformance with stated specifications.
5. The Bid Documents contain the provisions required for the requested item. Information obtained from an officer, agent, or employee of the Town or any other person shall not affect the risks or obligations assumed by the Bidder or relieve him/her from fulfilling any of the conditions of the bid.
6. Each Bidder is held responsible for the examination and/or to have acquainted themselves with any conditions at the job site which would affect their work before submitting a bid. Failure to meet this criteria shall not relieve the Bidder of the responsibility of completing the bid without extra cost to the Town of Glastonbury.
7. Any bid may be withdrawn prior to the above scheduled time for the opening of bids or authorized postponement thereof. Any bid received after the time and date specified shall not be considered. No Bidder may withdraw a bid within sixty (60) days after the actual date of the opening thereof. Should there be reasons why a Bid cannot be awarded within the specified period, the time may be extended by mutual agreement between the Town and the Bidder.
8. Each electronic bid submission must be accompanied by a COPY of the bid bond payable to the Town for ten percent (10%) of the total amount of the bid. Original bid bonds from all respondents must be mailed to the attention of the Purchasing Agent immediately (within 24 hours) following the virtual bid opening at the following address: Town of Glastonbury, PO Box 6523, Glastonbury, CT 06033-6523, Attn: Gina Consiglio, Purchasing Agent. The bid bond of the successful Bidder will be retained until the payment bond and performance bond have been executed and approved, after which it will be returned.

9. A 100% Performance and a 100% Payment bond are required of the successful bidder. This bond shall cover all aspects of the specification and shall be delivered to the Purchasing Agent prior to the issuance of a purchase order. The Performance and Payment Bond will be returned upon the delivery and acceptance of the bid items.
10. The Bidder agrees and warrants that in the submission of this sealed bid, they will not discriminate or permit discrimination against any person or group of persons on the grounds of race, color, religion, national origin, sex, or physical disability including, but not limited to blindness, unless it is shown by such Bidder that such disability prevents performance of that which must be done to successfully fulfill the terms of this sealed bid or in any manner which is prohibited by the laws of the United States or the State of Connecticut, and further agrees to provide the Human Relations Commission with such information requested by the Commission concerning the employment practices and procedures of the Bidder. An Affirmative Action Statement will be required by the successful Bidder.
11. Bidder agrees to comply with all of the latest Federal and State Safety Standards and Regulations and certifies that all work required in this bid will conform to and comply with said standards and regulations. Bidder further agrees to indemnify and hold harmless the Town for all damages assessed against the Town as a result of Bidder's failure to comply with said standards and/or regulations.
12. All correspondence regarding any purchase made by the Town of Glastonbury shall reference the Town's purchase order number. Each shipping container shall clearly indicate both Town purchase order number and item number.
13. Bidder is required to review the Town of Glastonbury Code of Ethics adopted July 8th, 2003 and effective August 1, 2003 and revised October 29, 2013 and effective November 8, 2013. Bidder shall acknowledge that they have reviewed the document in the area provided on the bid/proposal response page (BP). The selected Bidder will also be required to complete and sign an Acknowledgement Form prior to award. The Code of Ethics and the Acknowledgement Form can be accessed at the Town of Glastonbury website at [www.glastonbury-ct.gov](http://www.glastonbury-ct.gov). Upon entering the website scroll down to click on **Bids & Proposals** Icon which will bring you to the links for the Code of Ethics and the Acknowledgement Form. If the Bidder does not have access to the internet, a copy of these documents can be obtained through the Purchasing Department at the address listed within this bid/proposal.
- Non-Resident Contractors:** (if applicable)
14. Upon award the Town is required to report names of nonresident (out of state) Contractors to the State of Connecticut, Department of Revenue Services (DRS) to ensure that Employment Taxes and other applicable taxes are being paid by Contractors. **A single surety bond for 5% of the entire contract price is required to be filed with DRS by any unverified nonresident prime or general contractor (if awarded) where the contract price for the project is \$250,000 or more.** The contractor will be required to promptly furnish to the Town a copy of

the **Form AU-968 - Certificate of Compliance** issued by the State of Connecticut, DRS. See State of Connecticut **Notice SN 2012 (2)**.

15. Bidder shall include on a sheet(s) attached to its proposal a complete disclosure of all past and pending mediation, arbitration and litigation cases that the Bidder or its principals (regardless of their place of employment) have been involved in for the most recent five years. Please include a statement of the issues in dispute and their resolution. Acceptability of Bidder based upon this disclosure shall lie solely with the Town.
16. Bidder or its principals, regardless of their place of employment, shall not have been convicted of, nor entered any plea of guilty, or nolo contendere, or otherwise have been found civilly liable or criminally responsible for any criminal offense or civil action. Bidder shall not be in violation of any State or local ethics standards or other offenses arising out of the submission of bids or proposals, or performance of work on public works projects or contracts.
17. **It is the responsibility of the Bidder to check the Town's website before submitting bid for any addendums posted prior to bid opening.**

**IMPORTANT:**

- Failure to comply with general rules may result in disqualification of the Bidder.
- Municipal projects are exempt from Federal Excise Taxes, as well as, State of Connecticut Sales, Use and Service Taxes and should not be include in the Bidder's proposal.

## SECTION 1 - GENERAL

- 1.1 The Town of Glastonbury, Parks Department is seeking bids for the installation of a new protective netting system at the Minnechaug Golf Course located at 16 Fairway Crossing Glastonbury, CT 06033.
- 1.2 Technical questions regarding this bid shall be made in writing and directed to Lisa Zerio, Director of Parks and Recreation at [lisa.zerio@glastonbury-ct.gov](mailto:lisa.zerio@glastonbury-ct.gov). For administrative questions regarding the bidding procedures, please contact Gina J. Consiglio, Purchasing Agent at [purchasing@glastonbury-ct.gov](mailto:purchasing@glastonbury-ct.gov). All questions, answers, and/or addenda, as applicable will be posted on the Town's website at [www.glastonbury-ct.gov](http://www.glastonbury-ct.gov). (Upon entering the website scroll down to click on Bids & Proposals icon, then scroll down page to see the active bid table. You must click the Bid Title to view all bid details and document links). The request must be received at least five (5) days prior to the advertised response deadline. **It is the responsibility of the Bidder to check the Town's website before submitting bid for any addendums posted prior to bid opening.**
- 1.3 Bidders shall propose a total cost for installation of, including labor materials, equipment and transportation necessary for the installation of a new protective netting system in relation to the specifications herein. All work shall be performed during normal work days, Monday thru Friday 7:00 am - 3:30 pm, unless authorized by the Town. Work shall not interfere with the normal running operations of the course.
- 1.4 Bidder Qualifications: All work shall be performed by qualified personnel in compliance with all local, state and federal guidelines.
- 1.5 Variations: Any variations between the specifications herein are to be fully explained as part of the bid response.
- 1.6 Drawings: Bidder shall submit with their bid response complete detailed drawings of all equipment and layout as it would be installed at the Town's location specified herein.
- 1.7 Payment Terms shall be Net 30 to the bidder upon delivery and acceptance by the Town.

## **SCOPE OF SERVICES/SPECIFICATIONS**

### **PART 1 GENERAL**

#### **1.1 GENERAL DESCRIPTION**

Awarded CONTRACTOR shall furnish all labor, materials, equipment, and transportation necessary for the installation of a new protective netting system adjacent to #2 Tee box as shown on attached plans.

#### **1.2 SERVICE LOCATION**

Minnechaug Golf Course  
16 Fairway Crossing  
Glastonbury, CT 06033

#### **1.3 SCOPE OF SERVICES**

CONTRACTOR shall provide and install 100 linear feet of 50' tall netting as indicated and shown on Sheet C2 attached with these documents. The scope includes installation of three (3) new wooden support poles, as indicated on drawings, to support new netting system. New hardware, cable and netting, as specified below, shall be installed upon new wooden support poles. A pre-project site meeting shall be required prior to commencement of construction activities to coordinate the final location of new netting system and to coordinate entry and exit to project site. Exact quantity and size of new netting to be confirmed by CONTRACTOR. Reasonable care shall be taken to mitigate damages to existing surfaces during construction activities.

#### **1.2 SUBMITTALS**

Submit drawings, data, and information confirming that the poles, net material, and accessories conform to the requirements of Part 2 of this Section.

- A. Manufacturer's descriptive literature and catalog information on poles, net material, and hardware as applicable.
- B. Shop Drawings: Include plans, elevations, sections, details, and attachments to other work.

### **PART 2 PRODUCTS**

#### **2.1 BARRIER NETTING**

- A. Netting: LFS #930 polyester netting. The netting shall be made using four needle Rachel knotless construction, manufactured with UV treated yarn and additionally coated with a black resin dye and bonding treatment.

- B. Size: 2½” stretch mesh, 1” single bar measure. 116.7 average single mesh break strength, **determined in accordance with ISO standard 1806.**
- C. Attachment Twine: Black #48 braided polyester twine, 375 lb tensile strength, impregnated with UV inhibitor.
- D. Rope Border and Interior Riblines: Black 3/8” braided synthetic cover, parallel synthetic core, 3,500 lb. tensile strength. The rope boarder shall be attached to the net using a black UV dye treated #48 braided polyester twine with a minimum 375 lb. tensile strength. The attachment twine shall not be continuously tied to the net, but rather shall be tied at 6” on center for the full length of the rope boarder.

## 2.2 WOODEN POLES

- A. Wooden poles shall be Class 1, 60’ FULL LENGTH pressure treated poles.
- B. Species shall be Southern Yellow Pine, treatment shall be CCA to a final retention of .60# per cubic foot conforming to RUS 2011 Specifications.
- C. Foundations for poles shall be as per drawing C2.3 attached with these documents.
- D. All terminal poles and any tangent poles that lie within a curve or turn greater than 15 degrees shall be guyed to ground anchoring system. Refer to drawings attached to these documents.

## 2.3 HARDWARE & CABLE

- A. All hardware shall be galvanized unless specified differently, and shall conform to one of the following standards ANSI, ASTM, IEEE, and/or NEMA. Hardware components shall be matched so as to meet or exceed load capacity of the cable.
- B. Bolts: All bolts shall be minimum of 5/8 diameter and have minimum breaking strength equivalent to 10% greater the breaking strength of cable terminating to bolt. Bolts shall be hot dipped galvanized.
- C. Cable Clamps: Three bolt curved cable clamps are required at each pole to support all horizontal cables. One bolt clamps are required to support the vertical cable on every pole at every horizontal cable intersection except for the top and bottom horizontal cable.
- D. Vertical Rollers shall be used to terminate the vertical cables at top and bottom of each pole. Rollers shall be 1 7/8” in diameter and 7/8” thick with an 11/16” hole in the



center.

- E. 2 ¼” x 3/16” Square Washers shall be used to reinforce both sides of bolt holes in poles.
- F. Helical Anchors: All guy wire locations shall terminate into a 10” single helical power hub with ¾” diameter x 7’ anchor rod with twin eye.
- G. Guy Guards: All guy wire shall include a high visible guy guard, minimum of 8’ in length. Attachment- short lock strap. Preformed Products or similar.
- H. All horizontal cables shall terminated to the pole using a 5/8” Thimble eyenut.
- I. Attachment clips shall be 9/32” galvanized steel carabineer attachment snap.
- J. Cable: All cable shall be minimum of 5/16” galvanized steel Extra High Strength (EHS) 1x7 strand cable. All cable terminated via matching size pre-formed grip.

### **PART 3 EXECUTION**

#### **3.1 DELIVERY, STORAGE, AND HANDLING**

New Wood Poles, Net Materials, and Accessories:

1. Protect, support, and handle in a manner to prevent damage to the poles, net materials, and accessories.
2. Use implements, tools, facilities, and equipment suitable for proper and safe protection and handling of poles, netting materials, and accessories.
3. Remove poles, net materials, and accessories that are damaged beyond repair, in the opinion of Owner designated representative.

#### **3.2 PREPARATION**

New Poles, Net Materials, and Accessories:

Inspect before poles, net materials, and accessories are installed. Coordinate all layout with owner representative prior to beginning work.

#### **3.3 INSTALLATION**

##### **A. Qualifications**

1. Contractor shall have a minimum of ten years experience installing netting of a similar type construction, and shall submit five references for similar installations.

##### **B. Wood Pole Installation**

1. Poles must be placed plumb and true with spacing as per drawing requirements; embedment shall be per drawing details. In no instance shall the table cable hardware be installed closer than 6" from the top of the pole.
2. Poles borings shall be of sufficient size and orientation so as to ensure that the entire area of the boring can be properly backfilled and hydraulically compacted.
3. Poles shall be guyed at all end conditions, and at any turns in the line of the netting greater than 15 degrees so as to prevent deformation of the pole.

C. Hardware and Netting Installation

1. All hardware to be installed using through bolted connections properly reinforced on each side of the pole.
2. Lock washers shall be installed at each bolted connection as per drawing.
3. Guy hooks shall be used to attach guy cables to the poles.
4. Attachment clips are to be attached to the rope boarder at 2' on center. Clips shall be installed so as to attach to the support cable and rope boarder only. The clip shall not be attached so as to encompass the net or attachment twine. Continuously sewn rope boarders and riblines that require clipping the net with the rope boarder will not be allowed.
5. Vertical cables shall be installed on each pole.
6. Horizontal cables shall be installed parallel to the ground and each other.
7. Cables shall be tensioned with sufficient force to minimize sag between support poles.
8. Cross or "X" bracing cables shall not be used between the poles.
9. Netting Pannels shall be fabricated to fit exactly to all cable and pole locations.
10. Rope borders shall be installed at the net perimeter and all horizontal cable locations. Rope borders shall be constructed using a 3/8" rope with black synthetic cover, and a minimum tensile strength of 3,500 lbs.

D. Installation Clean Up and Inspection

Clean up debris and unused material, and remove from the site. Owner representative shall inspect all completed work and formally approve final completion of project.

**END OF SECTION**

## INSURANCE

The Bidder shall, at its own expense and cost, obtain and keep in force during the entire duration of the Project or Work the following insurance coverage covering the Bidder and all of its agents, employees and sub-contractors and other providers of services and shall name the **Town of Glastonbury and its employees and agents as an Additional Insured** on a primary and non-contributory basis to the Bidders Commercial General Liability and Automobile Liability policies. All policies shall contain a waiver of subrogation. **These requirements shall be clearly stated in the remarks section on the Bidder's Certificate of Insurance.** Insurance shall be written with insurance carriers approved in the State of Connecticut and with a minimum Best's Rating of A-VIII. In addition, all carriers are subject to approval by the Town. Minimum Limits and requirements are stated below:

1) Worker's Compensation Insurance:

- Statutory Coverage
- Employer's Liability
- \$1,000,000 each accident/\$1,000,000 disease-policy limit/\$1,000,000 disease each employee
- A Waiver of Subrogation shall be provided in favor of the Town of Glastonbury and its employees and agents

2) Commercial General Liability:

- Including Premises & Operations, Products and Completed Operations, Personal and Advertising Injury, Contractual Liability and Independent Contractors.
- Limits of Liability for Bodily Injury and Property Damage  
Each Occurrence \$1,000,000  
Aggregate \$2,000,000 (The Aggregate Limit shall apply separately to each job.)
- A Waiver of Subrogation shall be provided in favor of the Town of Glastonbury and its employees and agents

3) Automobile Insurance:

- Including all owned, hired, borrowed and non-owned vehicles
- Evidence a Combined Single Limit of Liability for Bodily Injury and Property Damage: Per Accident \$1,000,000
- A Waiver of Subrogation shall be provided in favor of the Town of Glastonbury and its employees and agents

The Bidder shall direct its Insurer to provide a Certificate of Insurance to the Town before any work is performed. The Contractor shall be responsible to notify the Town 30 days in advance with written notice of cancellation or non-renewal. The Certificate shall evidence all required coverage including the Additional Insured on the General Liability and Auto Liability policies. The Bidder shall provide the Town copies of any such insurance policies upon request.

## INDEMNIFICATION

To the fullest extent permitted by law, the Bidder shall indemnify and hold harmless the Town of Glastonbury and its consultants, agents, and employees from and against all claims, damages, losses and expenses, direct, indirect or consequential (including but not limited to fees and charges of engineers, attorneys and other professionals and court and arbitration costs) to the extent arising out of or resulting from the performance of the Bidder's work, provided that such claim, damage, loss or expense is caused in whole or in part by any negligent act or omission by the Bidder, or breach of its obligations herein or by any person or organization directly or indirectly employed or engaged by the Bidder to perform or furnish either of the services, or anyone for whose acts the Bidder may be liable.

**BID RESPONSE PAGE**

**BID NO:** GL-2024-26      **DATE & TIME DUE:** 03/21/2024 @ 11:00AM  
**DATE ADVERTISED:** 3/8/2024      **NAME OF PROJECT:** Minnechaug Golf Course Netting Project

**The Bidder acknowledges receipt of the following Addenda if issued:**

Addendum 1 \_\_\_\_\_(Initial/Date) Addendum 2 \_\_\_\_\_(Initial/Date) Addendum 3 \_\_\_\_\_(Initial/Date)

**It is the responsibility of the bidder to check with the Town’s Website for any Addenda before submitting the proposal.**

<b>Item No.</b>	<b>Item Description</b>	<b>Total Cost</b>
1	Installation of a new protective netting system, adjacent to #2 Tee box. This includes all labor, materials, equipment and transportation necessary.	\$
<b>Total Bid</b>		\$

\$ \_\_\_\_\_  
**(Total bid written amount)**

**OTHER ITEMS REQUIRED WITH SUBMISSION OF BID PROPOSAL:**

The following bid checklist describes items required for inclusion with the above-referenced bid proposal package. It is provided for the convenience of the bidders and, therefore, should not be assumed to be a complete list.

- \_\_\_\_\_ 1. Included Disclosure of Past and Pending Mediation, Arbitration, and Litigation cases against the Bidder or its Principals as per Section 12 of the Information for Bidders.
- \_\_\_\_\_ 2. Checked Town web site for Addenda and acknowledged Addenda on page BP-1.
- \_\_\_\_\_ 3. Acknowledged Code of Ethics on page BP-2.
- \_\_\_\_\_ 4. Included warranty and any warranty extension by manufacturer.
- \_\_\_\_\_ 5. Included Manufacturer’s Product Data as required.
- \_\_\_\_\_ 6. Included Bidder Qualifications as required.
- \_\_\_\_\_ 7. Complied with or exceeded specifications and included explanation of exceptions to specifications if any.

Bidder’s Name: \_\_\_\_\_

**NON-COLLUSION AFFIDAVIT:**

By submission of this bid, the Bidder certifies, and in the case of a joint bid each party thereto certifies as to their own organization that this bid has been arrived at independently without consultation, communication, or agreement as to any matter relating to this bid with any other Bidder or with any competitor.

**CODE OF ETHICS:**

I/We have reviewed a copy of the Town of Glastonbury's Code of Ethics and agree to submit a Consultant Acknowledgement Form if I/We are selected. Yes\_\_ No\_\_\_\_\_\*

\*Bidder is advised that effective August 1, 2003, the Town of Glastonbury cannot consider any bid or proposal where the Bidder has not agreed to the above statement.

Respectfully submitted:

\_\_\_\_\_  
Type or Print Name of Individual

\_\_\_\_\_  
Doing Business as (Trade Name)

\_\_\_\_\_  
Signature of Individual

\_\_\_\_\_  
Street Address

\_\_\_\_\_  
Title

\_\_\_\_\_  
City, State, Zip Code

\_\_\_\_\_  
Date

\_\_\_\_\_  
Telephone Number/Fax Number

\_\_\_\_\_  
E-Mail Address

\_\_\_\_\_  
SS# or TIN#

(Seal – If bid is by a Corporation)

Attest

**GENERAL NOTES:**

- Contact CBYD One Call (811) for public utility location prior to beginning digging activities.
- The contractor is responsible for following all safety provisions and codes issued by "OSHA". The contractor is also responsible for means, methods, sequencing, techniques, and procedures of construction and shall follow all state and local laws.
- Contractor shall field verify all field dimensions and site conditions prior to the commencement of construction and fabrication of materials.
- Care shall be taken to mitigate damages to existing surfaces during construction. Coordinate with customer representative all access points, laydown areas, and working area limits prior to the commencement of construction activities.
- All wooden support poles shall be installed true and plumb.
- Wooden support poles to be directly embedded within prescribed foundation boring. Excavated soil may be used for backfill, hydraulically tamped in 12" lifts (max). Remaining spoils may be evenly distributed around base of pole with excess soil removed from project location (coordinate with customer)
- All hardware shall be hot dipped galvanized unless otherwise noted. Refer to written specifications included in bidding package.
- Guy wires and helical anchors to be provided at each end pole location (see C2.1).

**PROJECT LOCATION**

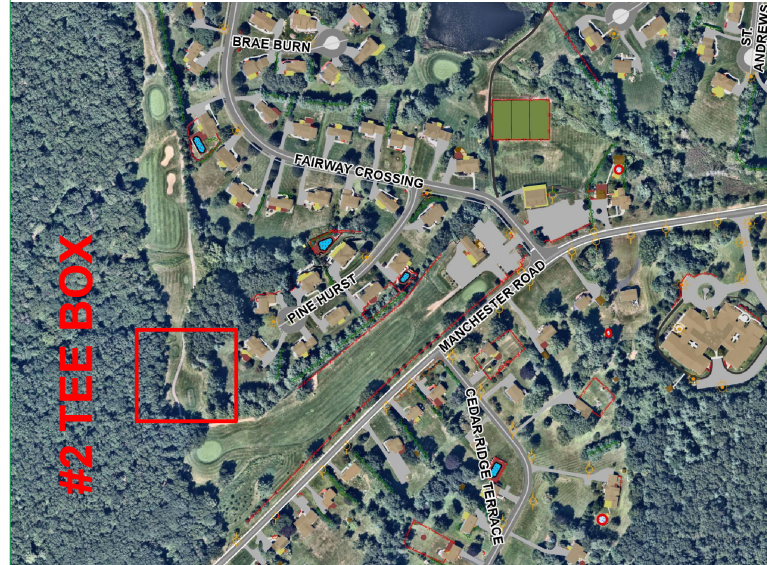

Location Map

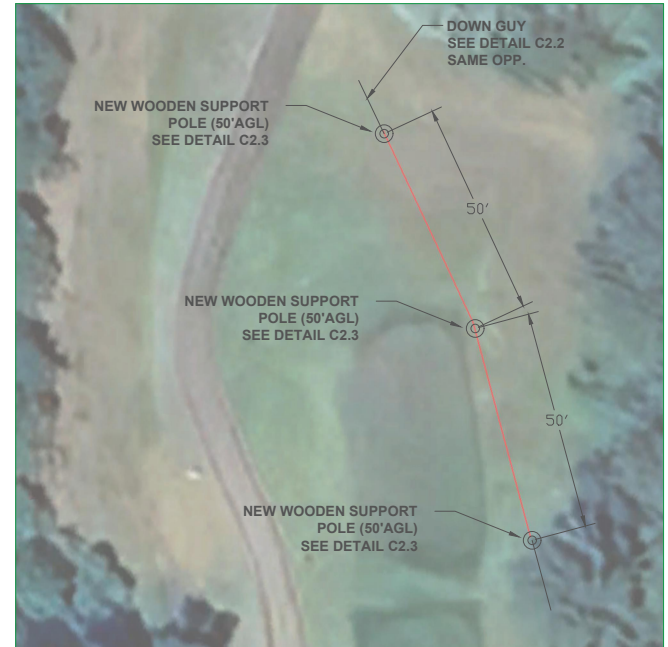

1 **SITE PLAN-PLAYOUT**  
NOT TO SCALE-BACKGROUND FROM GOOGLE EARTH

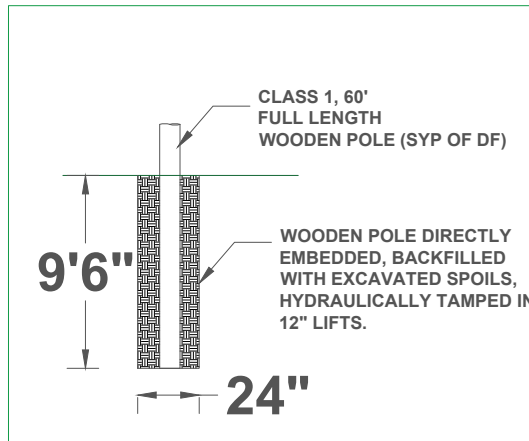

3 **TYPICAL DETAIL**  
POLE AND FOUNDATION

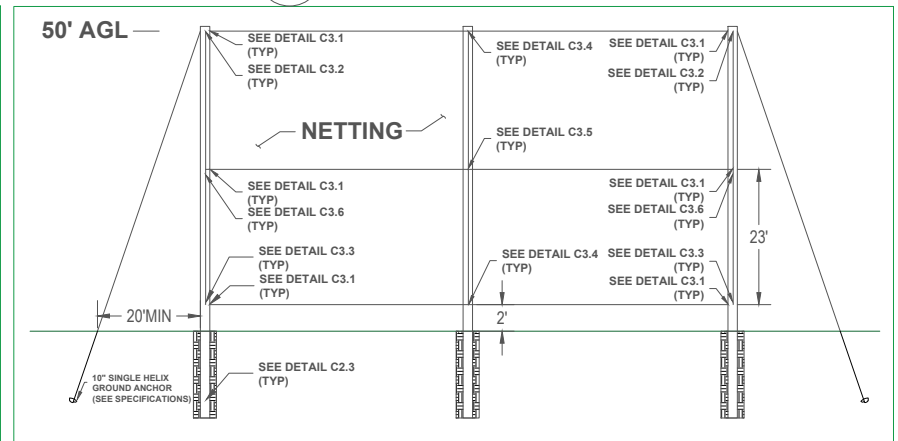

2 **SECTION PROFILE**  
NETTING SYSTEM

 <p>TOWN OF GLASTONBURY Parks and Recreation 2143 Main Street Glastonbury, CT 06033</p>	Drawn: TAT Date: 2.9.24 Checked: Approved	<p><b>#2 Tee Box Netting</b>                  Minnechaug Golf Course                  16 Fairway Crossing                  Glastonbury, CT 06033</p>	Sheet No. <p><b>C2</b></p>
--	--	--	-------------------------------

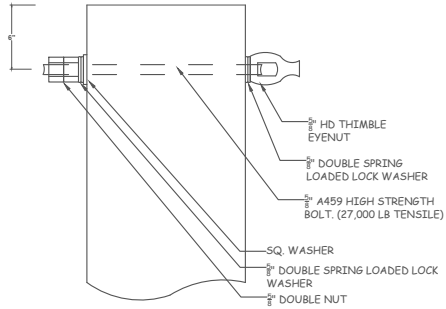

**1** **HARDWARE DETAIL**  
HORIZONTAL TERMINATION

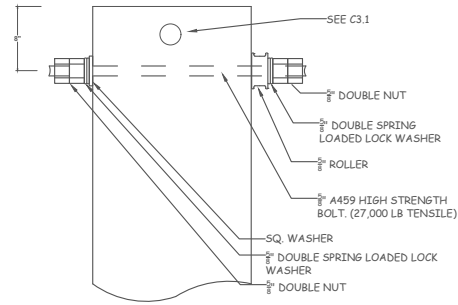

**2** **HARDWARE DETAIL**  
VERTICAL TERMINATION

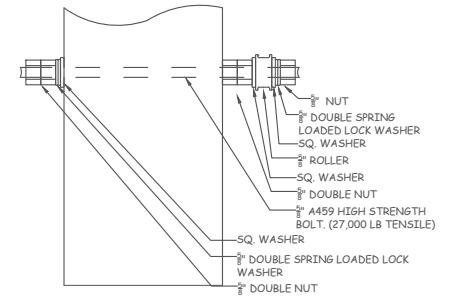

**3** **HARDWARE DETAIL**  
VERTICAL TERMINATION

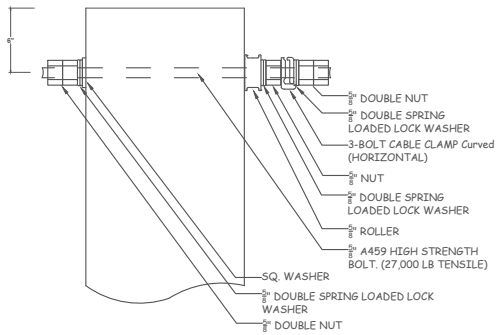

**4** **HARDWARE DETAIL**  
TOP OF TANGENT POLE

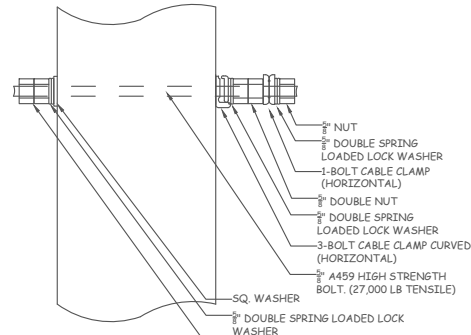

**5** **HARDWARE DETAIL**  
MID OF TANGENT POLE

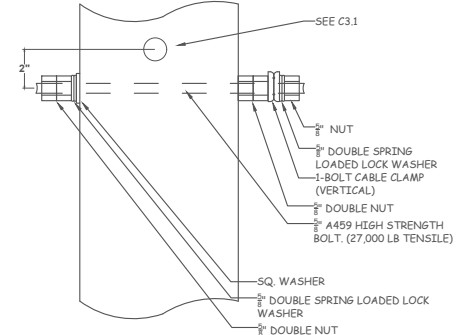

**6** **HARDWARE DETAIL**  
END POLE MID VERTICAL

**HARDWARE NOTES:**

1. REFER TO SPECIFICATIONS FOR CABLE SIZES. CABLE TO BE INSTALLED HORIZONTALLY (3) AND VERTICALLY ALONG EACH POLE.
2. NOTE THAT ALL HARDWARE/CABLE BEGIN 6" FROM TOP OF POLE.
3. ALL HARDWARE TO BE HOT DIPPED GALVANIZED (REFER TO SPECIFICATIONS)
4. ANY EXCESS BOLT THREAD SHALL BE TRIMMED BACK TO A MAXIMUM OF 3/4" CLEAR OF LAST NUT.



TOWN OF GLASTONBURY  
Parks and Recreation  
2143 Main Street  
Glastonbury, CT 06033

Drawn: TAT  
Date: 2.9.24  
Checked:  
Approved

**#2 Tee Box Netting**  
Minnechaug Golf Course  
16 Fairway Crossing  
Glastonbury, CT 06033

Sheet No.  
**C3**

ATTACHMENT B

**STANDARD BID BOND FORM**

KNOW ALL MEN BY THESE PRESENTS, That we, \_\_\_\_\_, hereinafter called the Principal, of \_\_\_\_\_, as Principal, and, \_\_\_\_\_ hereinafter called the Surety, a corporation organized and existing under the laws of the State of \_\_\_\_\_, and duly authorized to transact a surety business in the State of Connecticut, as Surety, are held and firmly bound unto the **Town of Glastonbury**, as Obligee, in the penal sum of ten (10) percent of the amount of the bid set forth in a proposal hereinafter mentioned, lawful money of the United States of America, for the payment of which, well and truly to be made to the Obligee, the Principal and the Surety bind themselves, their heirs, executors, administrators, successors and assigns, jointly and severally, firmly by these presents.

THE CONDITION OF THIS OBLIGATION IS SUCH, That, whereas the Principal has submitted or is about to submit a proposal to the Obligee related to a contract for the GL-2024-26 Minnechaug Golf Course Netting Project located at 16 Fairway Crossing Glastonbury, CT 06033

NOW, THEREFORE, if the said contract be awarded to the Principal and the Principal shall, within such time as may be specified, enter into the said contract in writing with the Town of Glastonbury and give the required bonds, with surety acceptable to the Obligee, or if the Principal shall fail to do so, pay to the Obligee the damages which the Obligee may suffer by reason of such failure not exceeding the penalty of this bond, then this obligation shall be void, otherwise to remain in full force and effect.

SIGNED, SEALED AND DELIVERED this \_\_\_\_\_ day of \_\_\_\_\_, 2024 \_\_\_\_\_

**Principal:** \_\_\_\_\_ (Name of Contractor)

By \_\_\_\_\_ (Contractor as Principal)  
Name: \_\_\_\_\_ (Print Name) \_\_\_\_\_  
Title: \_\_\_\_\_

**Surety:** \_\_\_\_\_ (Name of Surety)

By \_\_\_\_\_  
Name: \_\_\_\_\_ (Print Name)  
Title: \_\_\_\_\_