



FRONT



REAR

REVISION TABLE		
NUMBER	DATE	DESCRIPTION

RENDERING

Gardner Residence  
 154 Overlook Road  
 Glastonbury, CT 06033

DRAWINGS PROVIDED BY:  
 Hearthstone Homes, LLC  
 23 Valley View Road  
 Glastonbury, CT 06033

DATE:

10/3/2023

SCALE:

SHEET:

1



FRONT

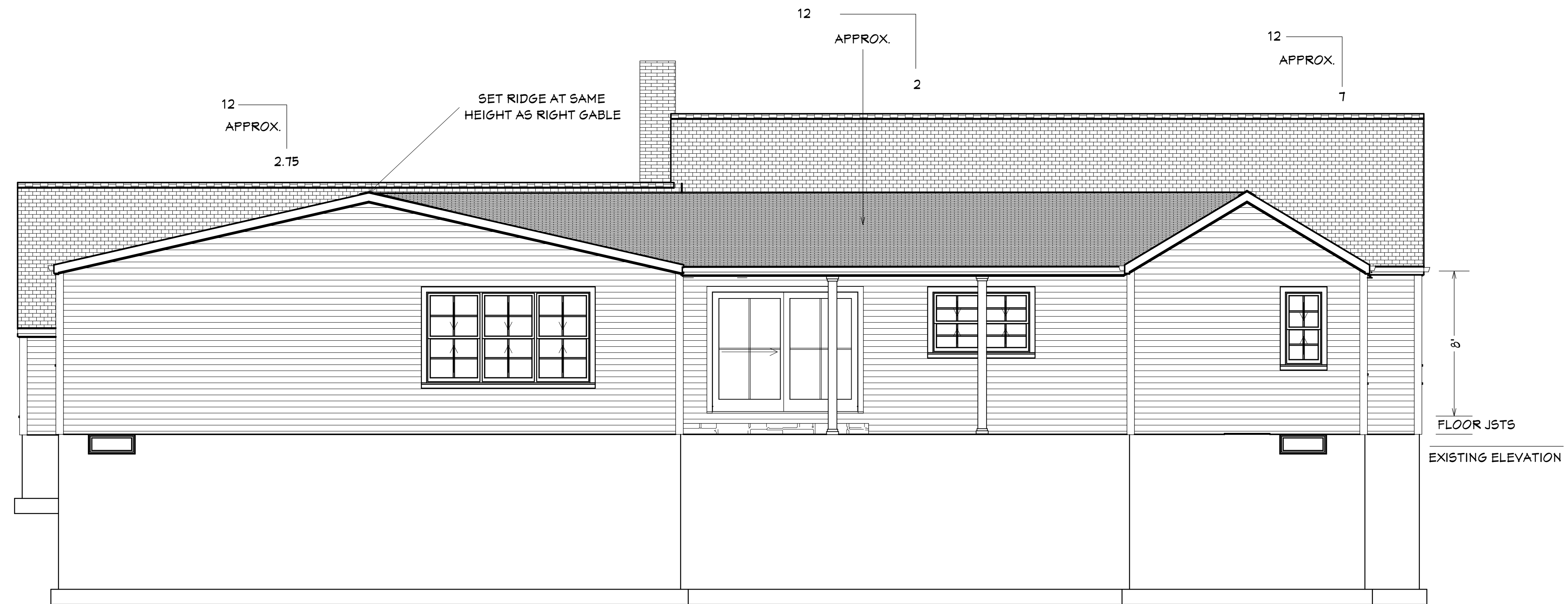

REAR

NUMBER	DATE	REVISED BY	DESCRIPTION

FRONT & REAR  
ELEVATIONS

Gardner Residence  
154 Overlook Road  
Glastonbury, CT 06033

DRAWINGS PROVIDED BY:  
Hearthstone Homes, LLC  
23 Valley View Road  
Glastonbury, CT 06033

DATE:

10/3/2023

SCALE:

1/4

SHEET:

2

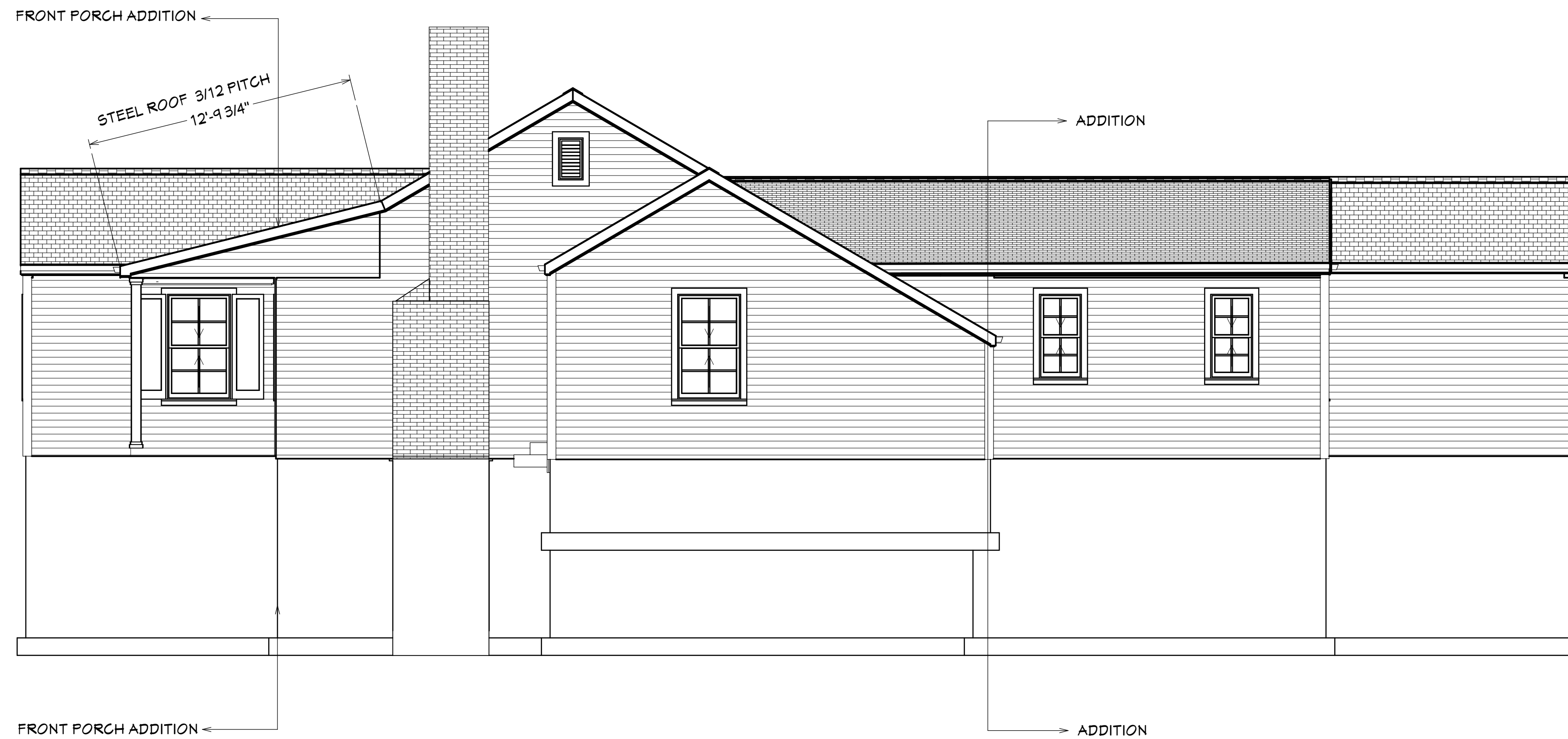

RIGHT

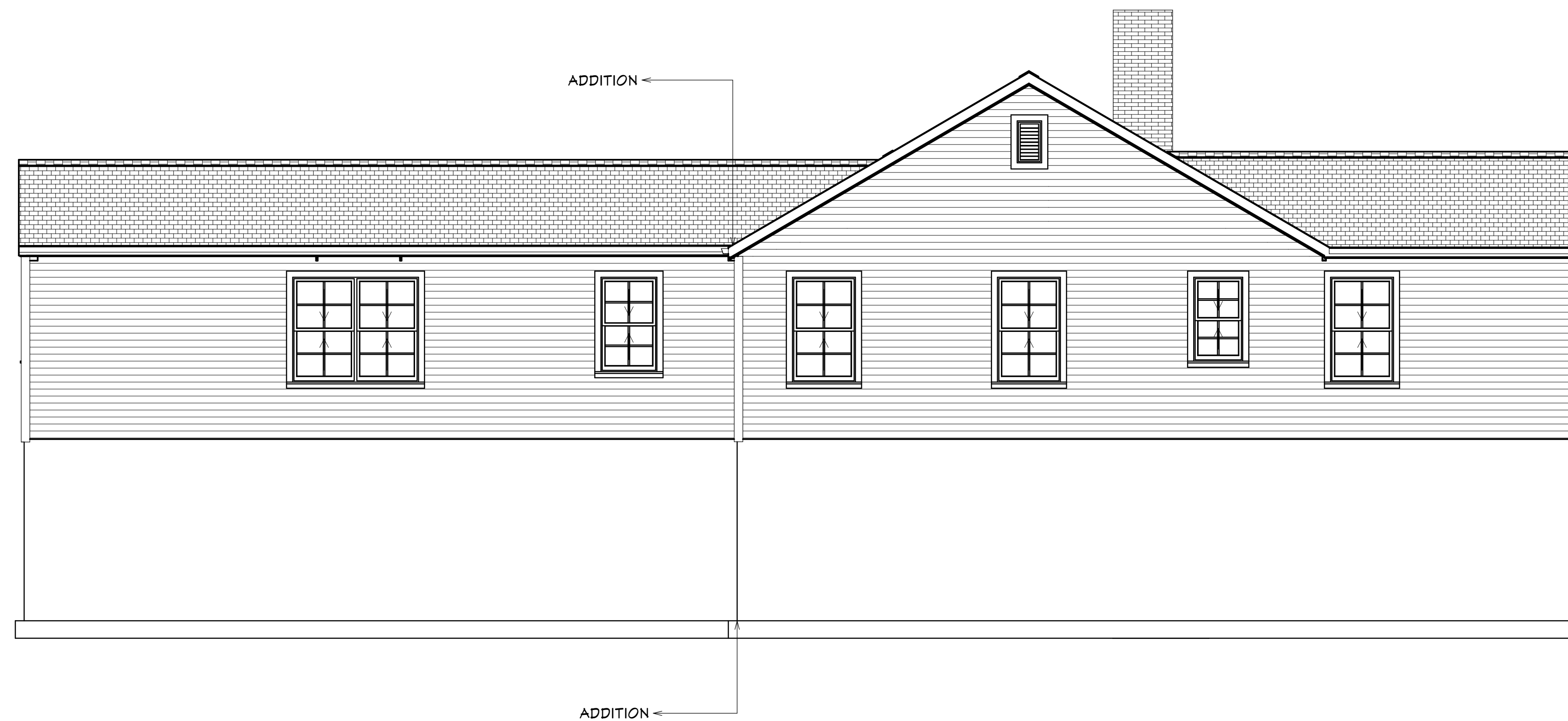

LEFT

REVISION TABLE	
NUMBER	DATE

SIDE ELEVATIONS

Gardner Residence  
 154 Overlook Road  
 Glastonbury, CT 06033

DRAWINGS PROVIDED BY:  
 Hearthstone Homes, LLC  
 23 Valley View Road  
 Glastonbury, CT 06033

DATE:

10/3/2023

SCALE:

1/4

SHEET:

3

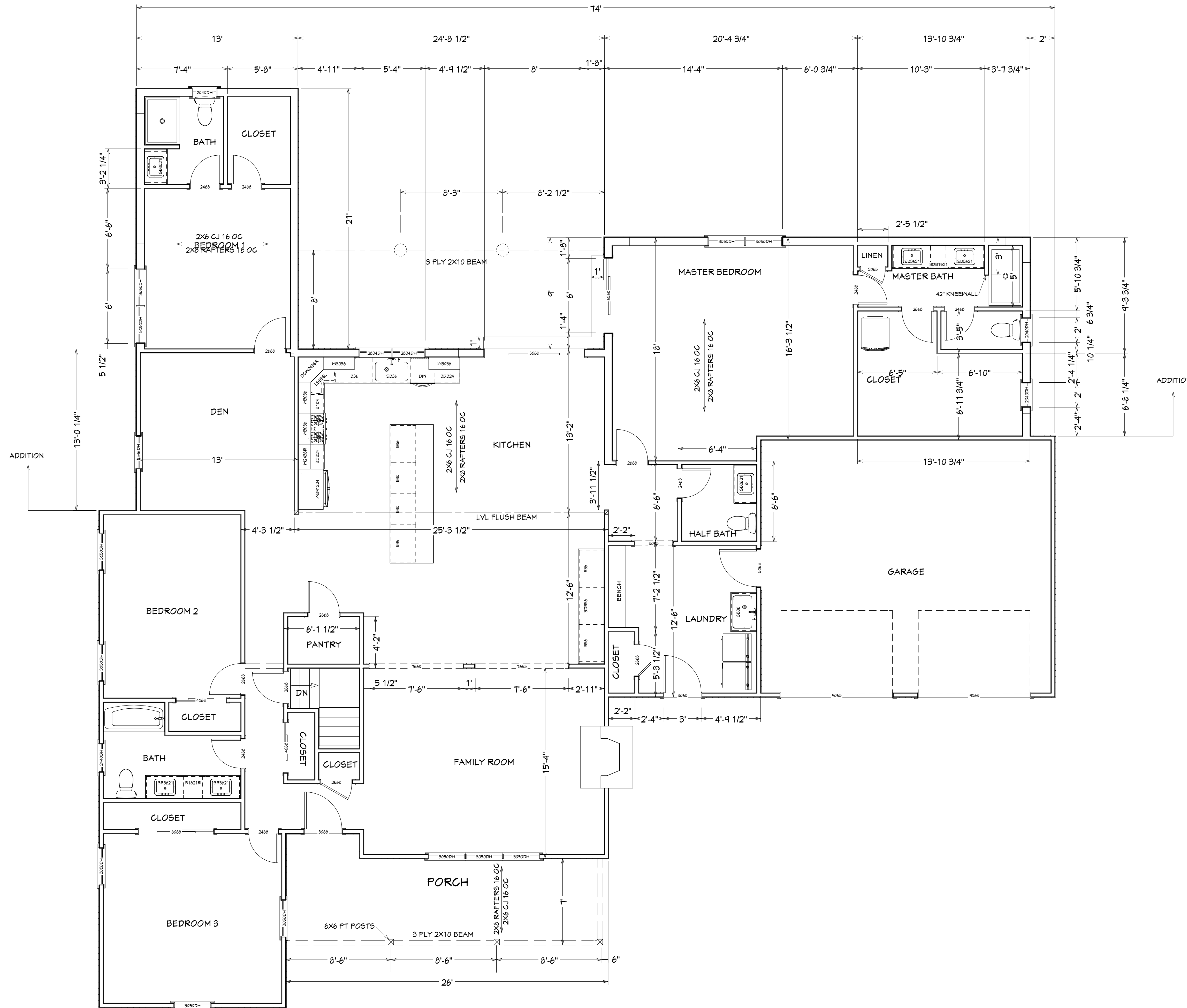

1. ALL FRAMING DF OR BETTER  
EXTERIOR WALLS 2X6  
INTERIOR WALLS 2X4
2. ALL SHEATHING 7/16" OSB
3. ALL PLATES PT FRAMING ON SILL SEAL
4. ALL SUBFLOORS, ADVANTEK OR EQUIV.
5. INSULATION FG BATTS UOS  
WALLS R-30  
FLAT CEILINGS R-60  
SLOPED CEILINGS R-30  
BASEMENT CEILING R-30  
BASEMENT WALLS R-10 RIDGID FOAM
6. 8' CEILINGS UOS
7. SMOKE AND CO DETECTORS INTERCONNECTED  
PER 2015 IRC, R314, 315 OF 2018 CT CODE
8. SEE JSTS AND BEAM PLAN FOR DESIGN LOADS PER  
ICC 2015 PORTION OF 2018, CT IRC R301.1
9. DESIGN COMPLIANT WITH IRC SEC R106.1.1
10. BRACED WALLS PER R602.3, R604, R106.1.3. ALL WALLS  
CS-WSP UOS. 7/16" OSB INSTALLED WITH 8d COMMON NAILS  
4" OC AT EDGES AND 12" OC AT INTERMEDIATE SUPPORTS FOR THE  
FIRST FLOOR AND 6" OC AT EDGES AND 12" OC AT INTERMEDIATE  
SUPPORTS FOR THE SECOND FLOOR.  
THE SHEATHING SHALL BE INSTALLED CONTINUOUSLY OVER  
THE EXTERIOR WALLS.  
INSTALL BLOCKING AT ALL PANEL EDGE JOINTS.
11. HURRICANE TIES AT ALL RAFTER OR TRUSS TO WALL PLATE CONNECTIONS

WINDOW SCHEDULE

QTY	SIZE	RO	TOW/AFF
1	3060 TWIN	T2X72	84
1	3060 TRIPLE	108X72	84
3	2040	24X48	84
1	2834	32X40	84

ALL 4 OVER 4

EXTERIOR MUD ROOM DOOR THERMATRU LH, FG, 3068 FULL LITE  
GARAGE MUD ROOM DOOR THERMATRU RH, 3068 FIRE RATED, SELF CLOSING  
SCHLAGE PLYMOUTH BLACK HARDWARE

NUMBER	DATE	REVISION BY	DESCRIPTION

FIRST FLOOR

Gardner Residence  
154 Overlook Road  
Glastonbury, CT 06033

DRAWINGS PROVIDED BY:  
Heathstone Homes, LLC  
23 Valley View Road  
Glastonbury, CT 06033

DATE:

10/3/2023

SCALE:

1/4

SHEET:

4

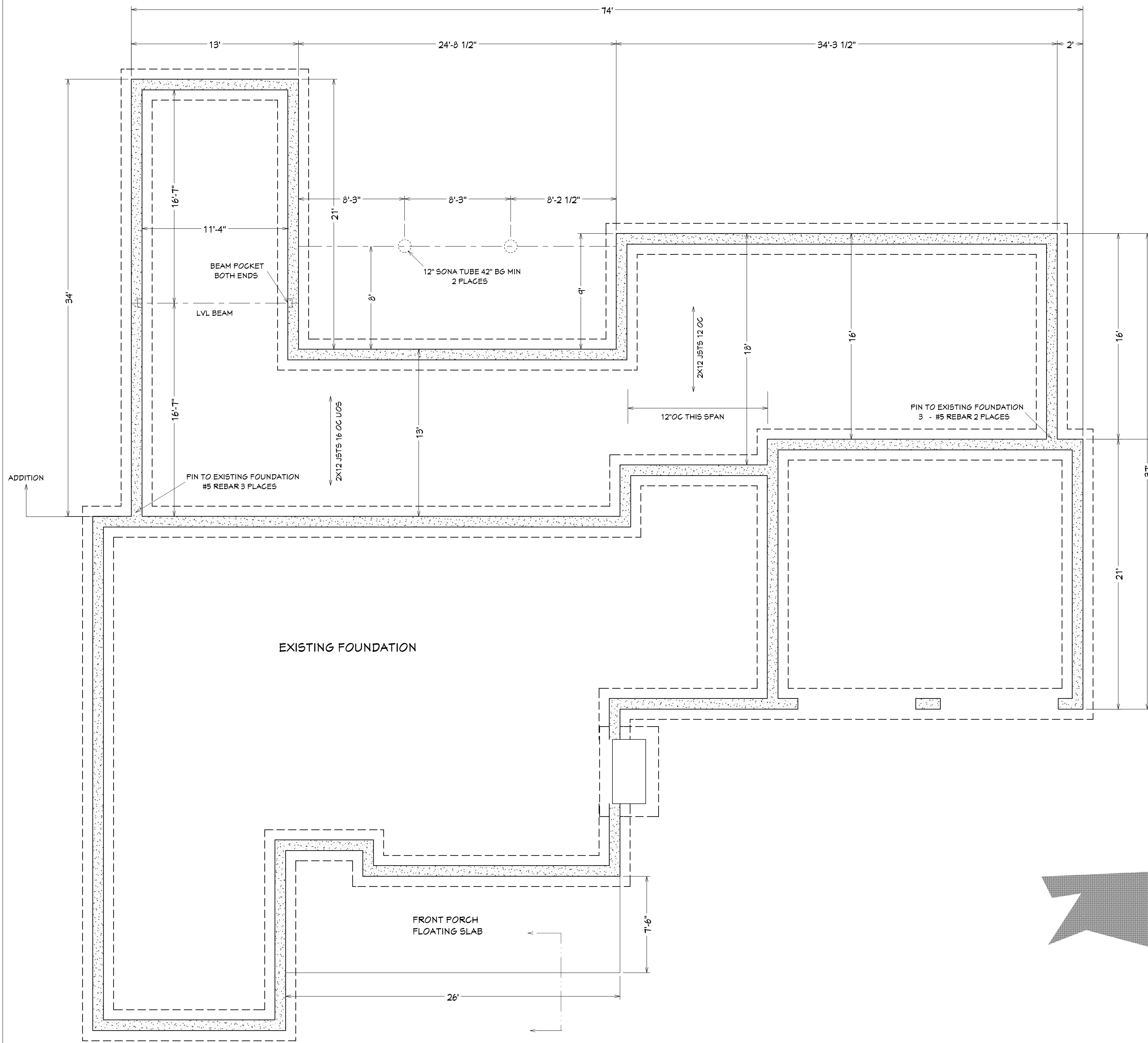

FOUNDATION PER R401-403  
 10"X42" FROST WALL 3000 PSI  
 PLATE ANCHORS 48" OC, 12" AT CORNERS  
 10X20 3000 PSI CONT CONCRETE FOOTINGS  
 2" THICK 3000 PSI SLAB WITH 6 MIL POLY  
 DAMP PROOF ENTIRE EXTERIOR  
 6" OF 3/4" CRUSHED STONE BELOW FOOTINGS AND SLAB  
 12" DIA SONA TUBES 3000 PSI

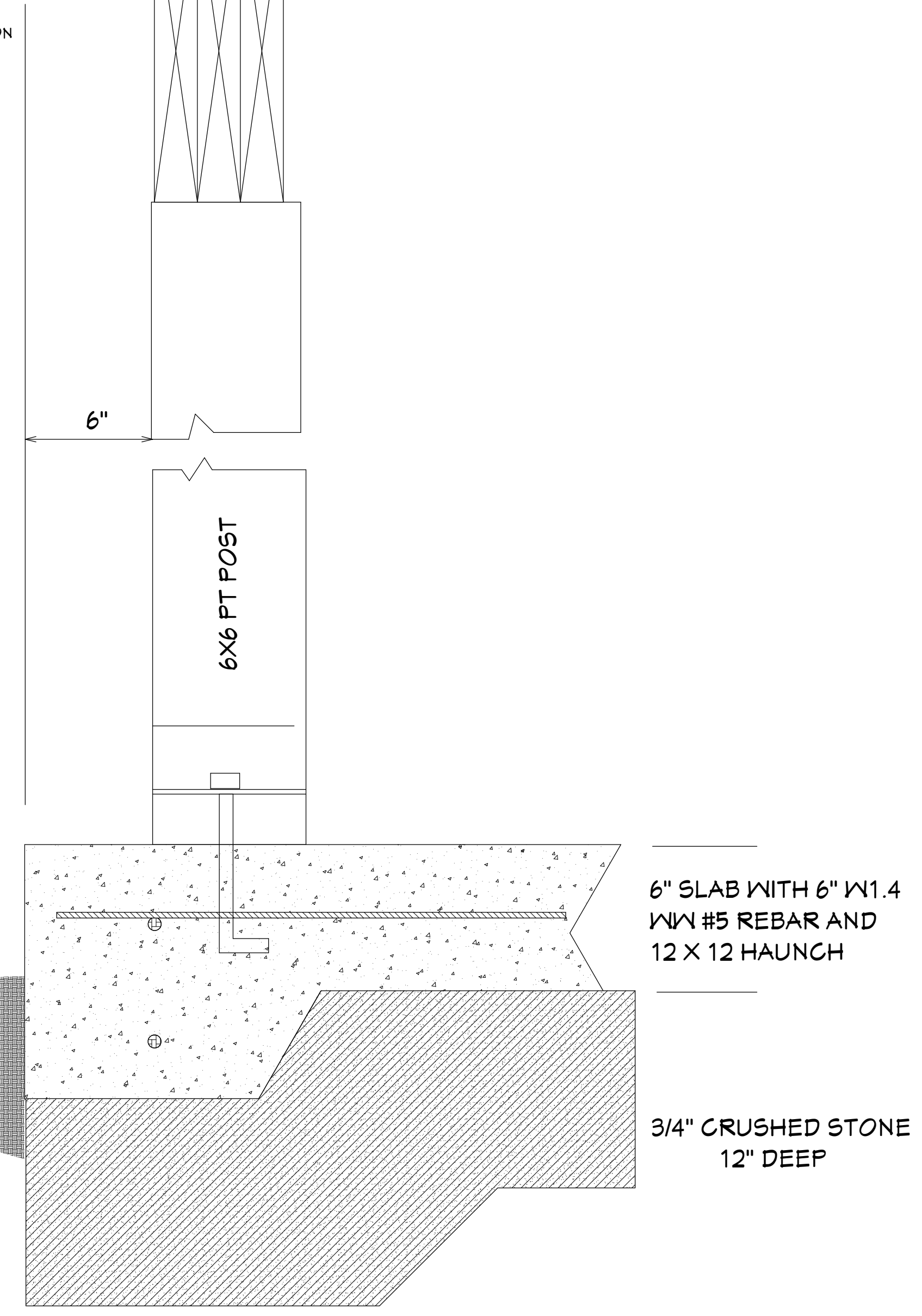
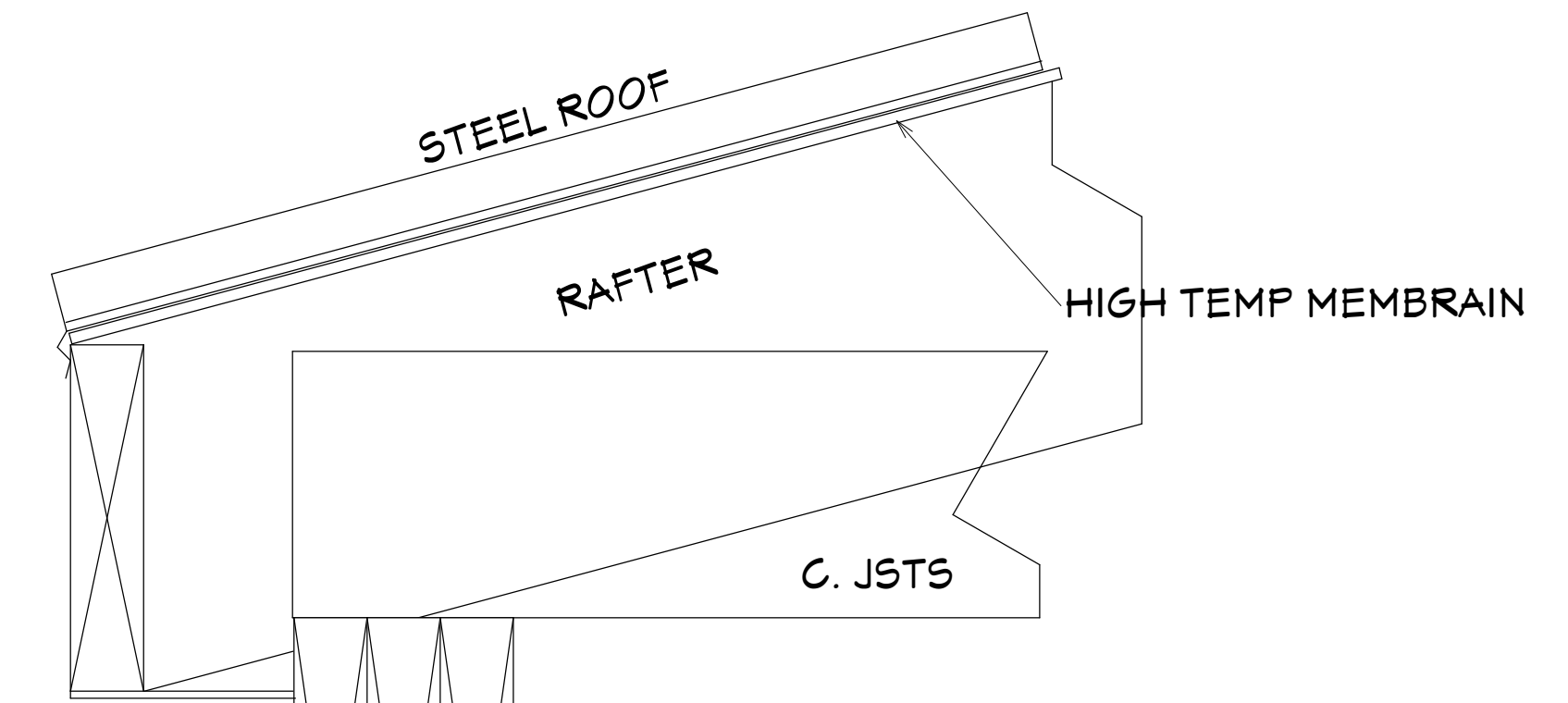

**FRONT PORCH CONCRETE SLAB SECTION**

REVISION TABLE	NUMBER	DATE	REVISOR	DESCRIPTION

**FOUNDATION**

**Gardner Residence**  
 154 Overlook Road  
 Glastonbury, CT 06033

**Drawings Provided By:**  
 Heathstone Homes, LLC  
 23 Valley View Road  
 Glastonbury, CT 06033

DATE:

10/3/2023

SCALE:

1/4

SHEET:

**5**

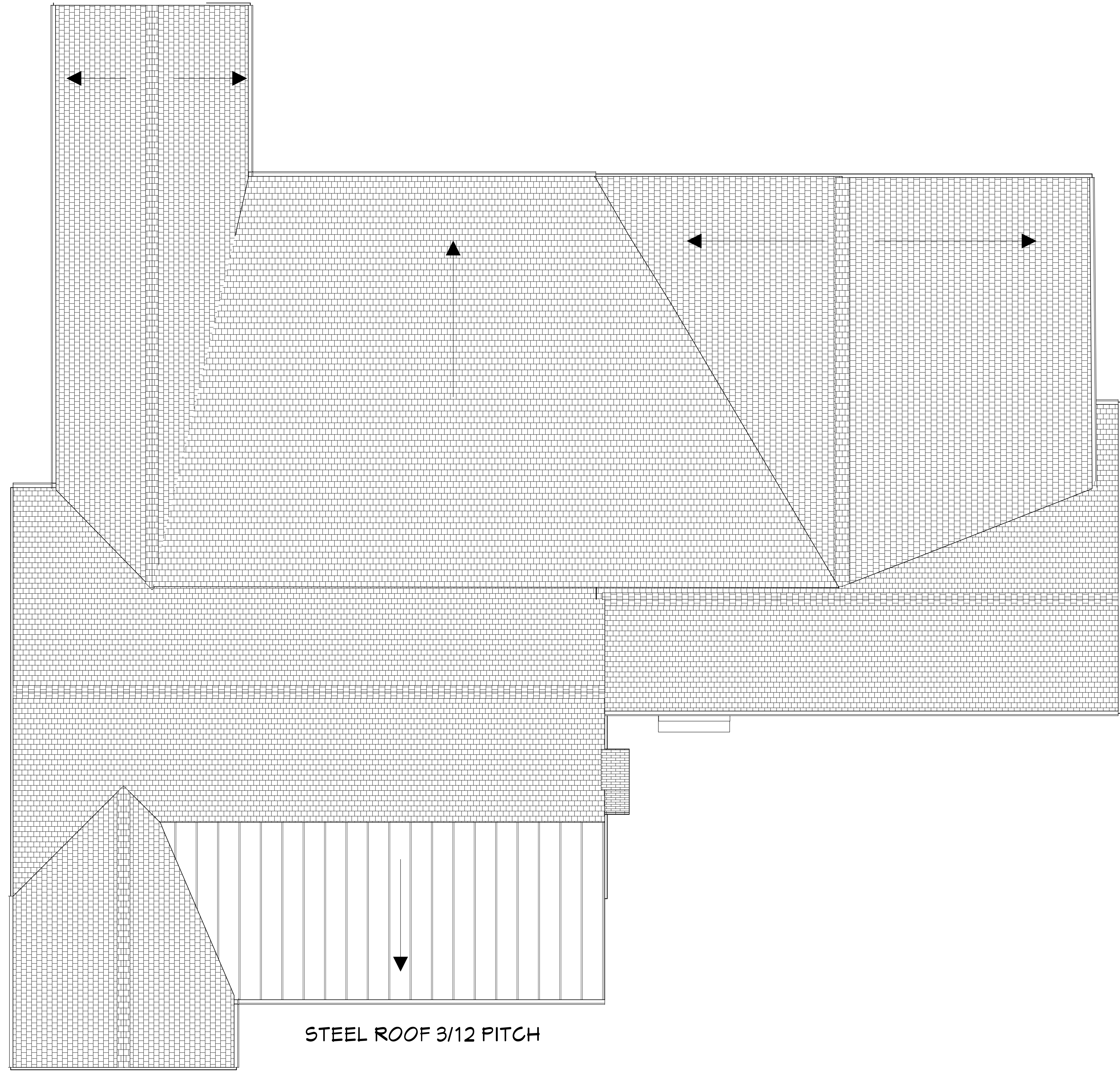

STEEL ROOF 3/12 PITCH

REVISION TABLE		
NUMBER	DATE	DESCRIPTION

ROOF

Gardner Residence  
 154 Overlook Road  
 Glastonbury, CT 06033

DRAWINGS PROVIDED BY:  
 Hearthstone Homes, LLC  
 23 Valley View Road  
 Glastonbury, CT 06033

DATE:

10/3/2023

SCALE:

1/4

SHEET:

6

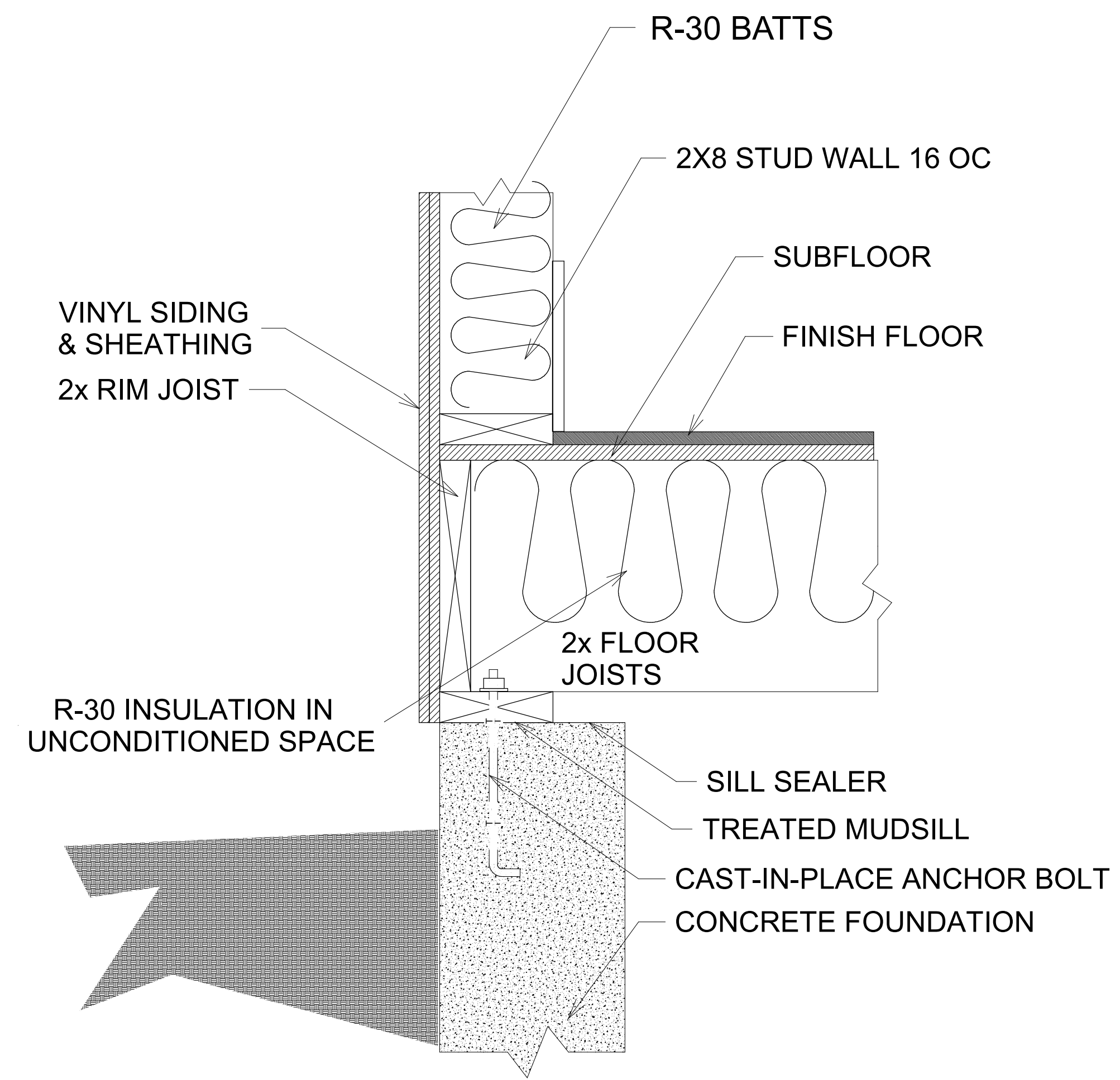

FLOOR AT FOUNDATION FRAMING

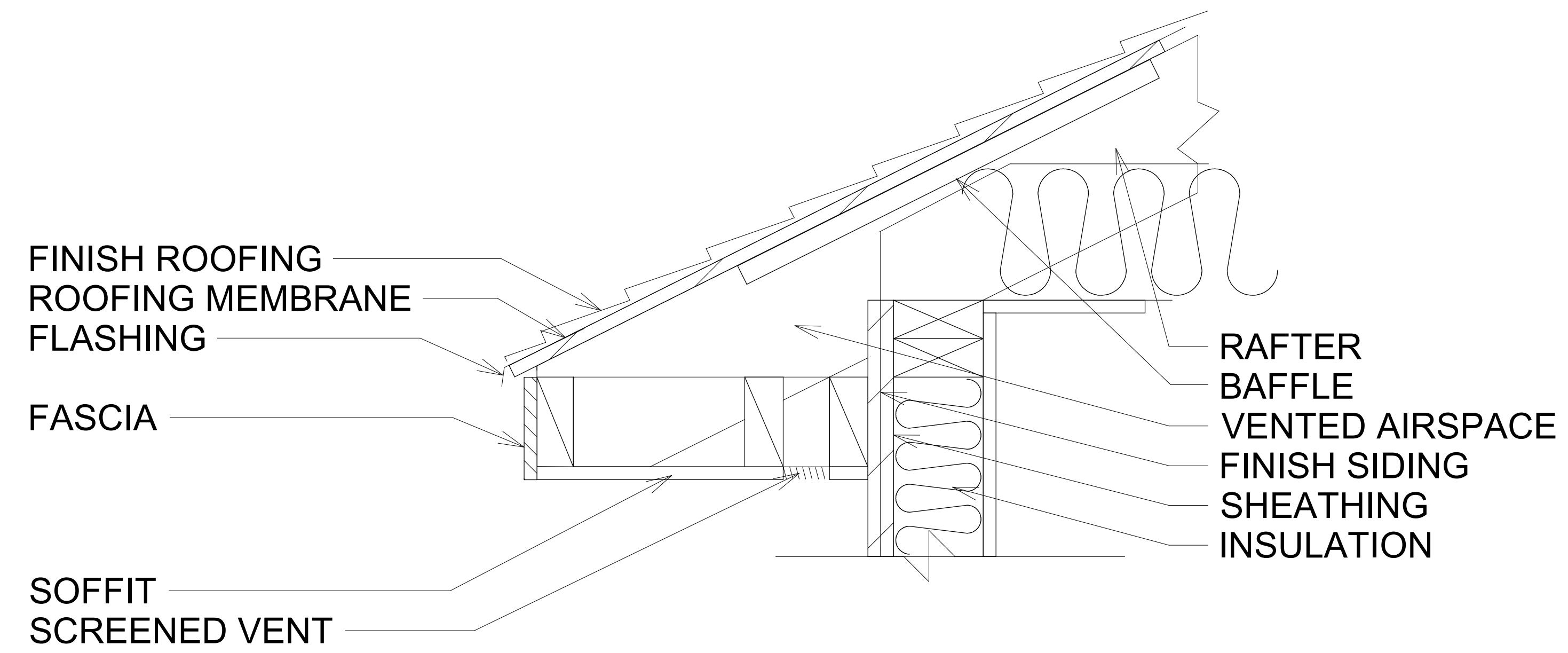

WALL AT ROOF VENTED SOFFIT

REVISION TABLE	
NUMBER	DATE

FRAMING DETAIL

Gardner Residence  
 154 Overlook Road  
 Glastonbury, CT 06033

DRAWINGS PROVIDED BY:  
 Heathstone Homes, LLC  
 23 Valley View Road  
 Glastonbury, CT 06033

DATE:

10/3/2023

SCALE:

SHEET:

7

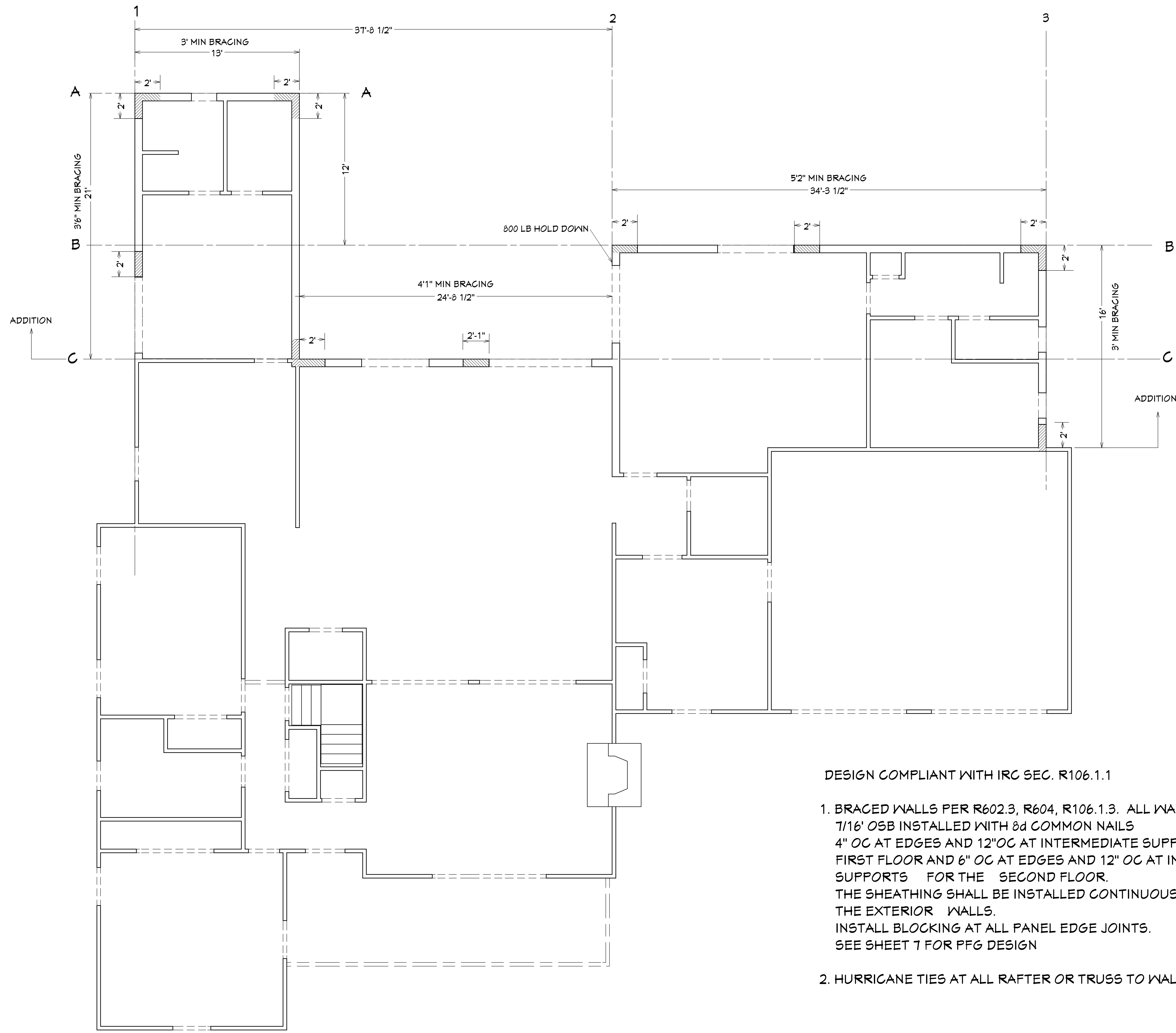

DESIGN COMPLIANT WITH IRC SEC. R106.1.1

- BRACED WALLS PER R602.3, R604, R106.1.3. ALL WALLS CS-WSP UOS.  
 7/16" OSB INSTALLED WITH 8d COMMON NAILS  
 4" OC AT EDGES AND 12" OC AT INTERMEDIATE SUPPORTS FOR THE FIRST FLOOR AND 6" OC AT EDGES AND 12" OC AT INTERMEDIATE SUPPORTS FOR THE SECOND FLOOR.  
 THE SHEATHING SHALL BE INSTALLED CONTINUOUSLY OVER THE EXTERIOR WALLS.  
 INSTALL BLOCKING AT ALL PANEL EDGE JOINTS.  
 SEE SHEET 7 FOR PFG DESIGN

- HURRICANE TIES AT ALL RAFTER OR TRUSS TO WALL PLATE CONNECTIONS

REVISION TABLE	
NUMBER	DATE

**BRACED WALLS**

**Gardner Residence**  
 154 Overlook Road  
 Glastonbury, CT 06033

**Drawings Provided By:**  
 Heathstone Homes, LLC  
 23 Valley View Road  
 Glastonbury, CT 06033

DATE:

10/3/2023

SCALE:

1/4

SHEET:

8



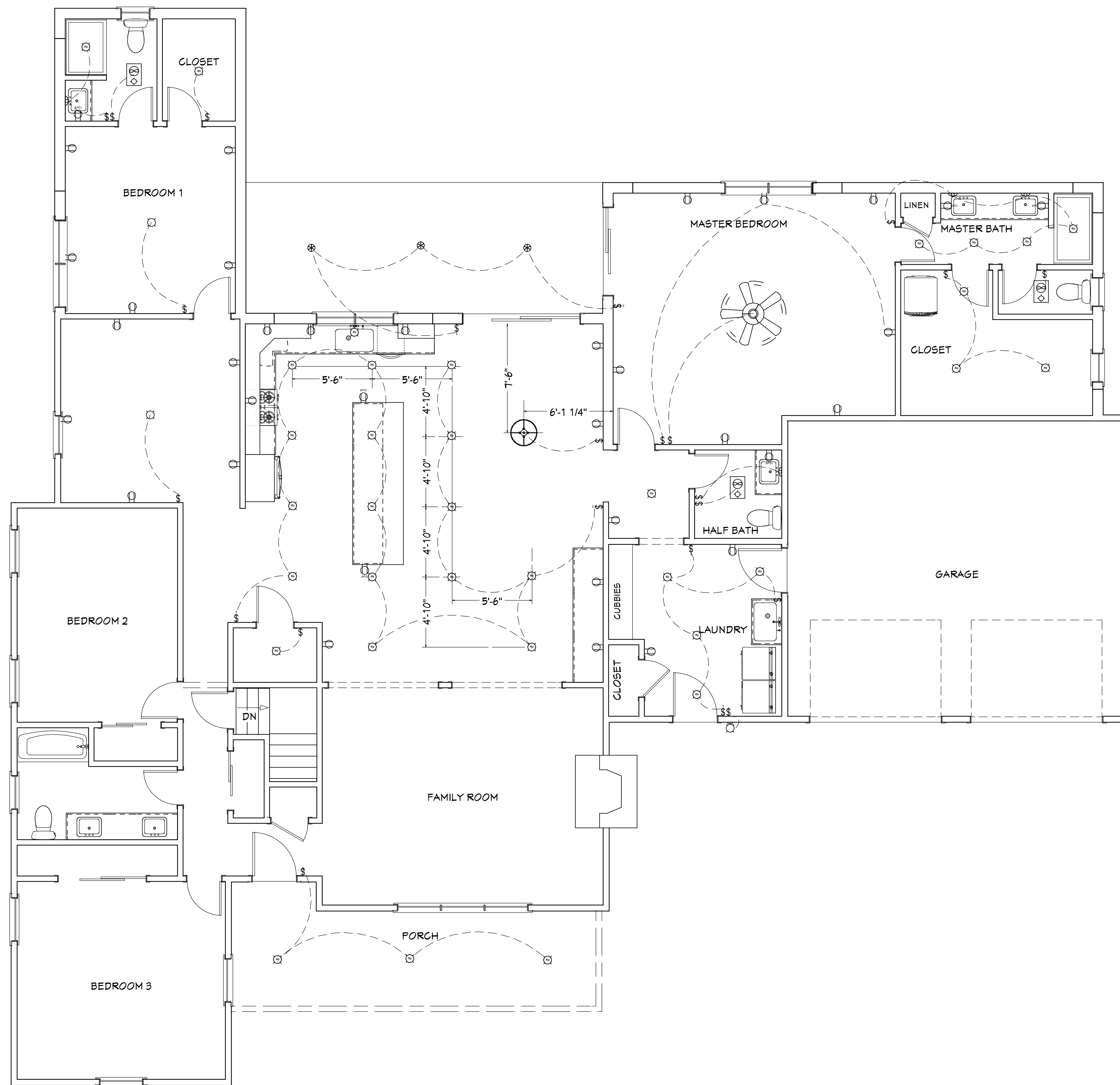

REVISION TABLE	
NUMBER	DATE

**ELECTRICAL**

**Gardner Residence**  
 154 Overlook Road  
 Glastonbury, CT 06033

DRAWINGS PROVIDED BY:  
**Heathstone Homes, LLC**  
 23 Valley View Road  
 Glastonbury, CT 06033

DATE:

10/3/2023

SCALE:

1/4

SHEET:

9