



Town of Glastonbury

Community Development

TO: Town Plan & Zoning Commission

FROM: Shelley Caltagirone, Director of Planning and Land Use Services

DATE: August 18, 2023

RE: Commercial and Recreational Vehicle Parking in Residence Zones

At the August 1st Town Council Meeting, the Council referred draft parking regulations for commercial and recreational vehicles in residence zones to the Town Plan & Zoning Commission (TPZ) for a recommendation. Attached are suggested revisions to Section 7 of the Town Center Zone regulations that may address concerns raised by the public regarding the need for greater flexibility in the regulations. These revisions are intended to allow greater flexibility for residents to park commercial vehicles for their personal use at their home while protecting public views. The draft regulations would also address the parking of recreational vehicles, boats, trailers, and mobile homes.

Currently, residents are permitted to park a maximum of one commercial vehicle on the lot, provided such commercial vehicle has a maximum capacity of one and one-half (1-1/2) tons, is owned by the owner or permanent resident of the property which it is to be parked, and is parked in the garage, barn or the rear yard of the property. Property owners may apply for a variance in all residential zones to park commercial vehicles in the driveway, or in front or side yards. In this instance, the applicant must demonstrate a hardship related to specific conditions of the property that do not affect the surrounding zone generally. Similar restrictions apply to the parking of boats, trailers, and mobile homes.

Staff reviewed the Town of Wethersfield's very detailed definition of commercial vehicles and zoning controls as model for the proposed regulations. This draft would change the following in the regulations:

1. expand the definition of commercial vehicles
2. add a definition for recreational vehicles
3. permit an unlimited number of commercial vehicles, boats, trailers, mobile homes, or recreational vehicles to be parked in a garage or barn, as of right
4. require a zoning permit for the parking of one commercial vehicle outdoors in the side or rear yards
5. require a zoning permit for the parking of one commercial vehicle in the driveway or with screening in the side or rear yards
6. require a zoning permit for the parking of one boat, trailer, mobile home, or recreational vehicle with screening in the side or rear yards

Property owners would continue to be able to apply for a variance in the event that they cannot meet the requirements.

The TPZ may forward the draft text amendment to the Council with the following motion:

MOVED, that the Town Plan & Zoning Commission favorably recommends to the Town Council (Zoning Authority) text amendments to the Building-Zone Regulations (Sections 2 and 7) to modify requirements for parking commercial and recreational vehicles, boats, trailers and mobile homes in residence zones as described in the memo regarding “Commercial and Recreational Vehicle Parking in Residence Zones” from the Office of Community Development dated August 18, 2023.

[Attachments:](#)

DRAFT Amendment to Building-Zone Regulations
Typical Vehicle Dimensions

DRAFT Amendment to Building-Zone Regulations

Amended for Commercial and Recreational Vehicle Parking in Residence Zones

August 18, 2023

Section 2: Definitions

2.xx Vehicle, Commercial

Any vehicle or equipment regularly used to carry, deliver, handle or move goods in the conduct of a business, commerce, profession, or trade, including: step vans, cargo vans, box trucks, flat beds, stake beds, buses, tractor trailers, dump trucks, wreckers, trailers, earth moving equipment, cement mixers and other similar construction equipment that has 2 or more of the following characteristics:

- a. Exceeds a gross weight vehicle rating (GWVR) of 10,000 pounds
- b. Exceeds 7 feet in height,
- c. Exceeds 20 feet in length,
- d. Has more than 2 axles,
- e. More than 4 tires in contact with the ground,
- f. Can carry more than 8 passengers,
- g. Designed to sell food or merchandise directly from the vehicle,
- h. Bears signs or markings identifying the owner or business,
- i. Has modifications to facilitate the carrying of goods or equipment.

2.xx Vehicle, Recreational

A vehicle which is (1) built on a single chassis, (2) four hundred (400) square feet or less when measured at the largest horizontal projection, (3) designed to be self-propelled or permanently towable by a light-duty truck, and (4) designed primarily not for use as a permanent dwelling but as temporary living quarters for recreational, camping, travel or seasonal use.

Section 7: Accessory Uses and Structures

7.1.b Special Accessory Uses and Structures

1. Permitted special accessory uses and structures. Special accessory uses and structures are permitted in the residence zones and on lots in non-residence zones on which permitted on non-conforming residential uses are situated as set forth in Section 4 of these Regulations and shall be subject to such additional conditions as are set forth herein. Special accessory uses and structures shall include: customary home occupation, garage or carport, the parking of a commercial vehicle, the parking or storage of a boat, trailer, mobile home or recreational vehicle, guest house, bathing or swimming pool and bath house, roadside stand, the stabling of horses, the keeping and housing of livestock or poultry for domestic purposes only, traditional professional medical/dental care facility, and storage containers.

2. Conditions for special accessory uses and structures. In addition, the requirements for height, location and maximum land area for customary accessory uses and structures, special accessory uses and structures shall be subject to the following conditions:

[Subsection "a" and "b" not include for brevity]

- c.) The parking of commercial vehicles owned or leased by the owner or permanent resident of the property in a garage or barn is permitted as of right as an accessory use.
- d.) The parking of one (1) commercial vehicle with the following characteristics may be permitted as an accessory use subject to the issuance of a zoning permit from the Zoning Enforcement Officer (ZEO) and subject to the following restrictions:
1. The commercial vehicle must be owned or operated by the resident of the dwelling.
 2. The vehicle shall have no more than 2 (two) axles and no more than 6 (six) tires in contact with the ground.
 3. The vehicle shall be parked so as not to obstruct the view of traffic from adjacent driveways or streets.
 4. Only commercial vehicles that are the resident's primary means of transportation to and from their place of work are permitted to be parked.
 5. The vehicle shall not exceed twelve thousand (12,000) pounds GVWR.
 6. The vehicle shall not exceed eight (8) feet in height from the base of the wheel to the top.
 7. The vehicle shall not exceed twenty-five (25) feet in length.
 8. Any signs, logos, advertising or markings identifying the owner or registrant, trade, business, service or commodity shall be limited to not more than 2 and each is limited to not more than twelve (12) square feet in area.
 9. The vehicle shall be parked (1) in the driveway or (2) on a durable all-weather surface in the side or rear yard screened from view from neighboring properties or from a public right-of-way with appropriate vegetative buffering, fencing, earthen berms or a combination thereof.
 10. The ZEO may require applicants to submit information about the commercial vehicle on a form provided by the Town.

- e) A maximum of one (1) boat, trailer, mobile home, or recreational vehicle which is owned by the owner or permanent resident of the property may be parked or stored on the lot. The vehicle may be parked or stored in a garage or barn, as of right. If the vehicle cannot fit in a garage or barn, the ZEO may allow the vehicle to be parked on a durable all-weather surface in the side or rear yard when screened from view from neighboring properties or from a public right-of-way with appropriate vegetative buffering, fencing, earthen berms or a combination thereof upon issuance of a zoning permit. No such boat, trailer, mobile home, or recreational vehicle shall be occupied for living, sleeping or cooking purposes or for carrying on business except as provided in Section 6.10 of these Regulations.

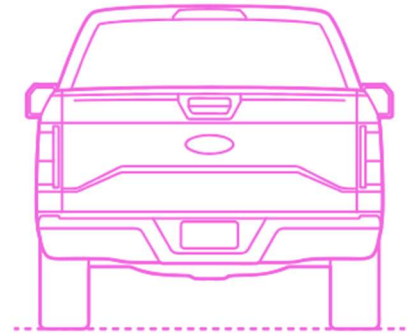
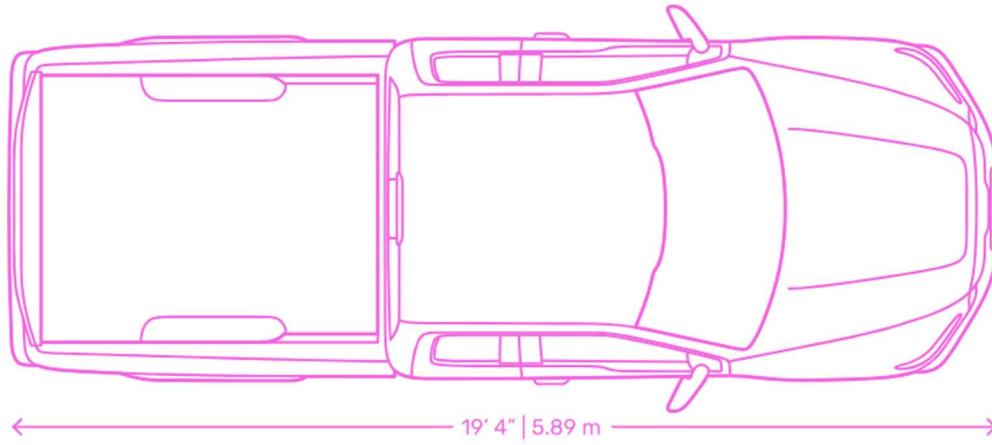
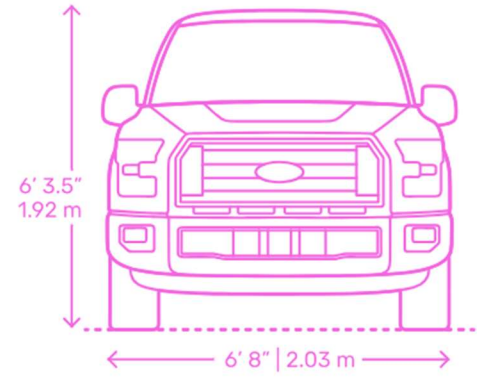
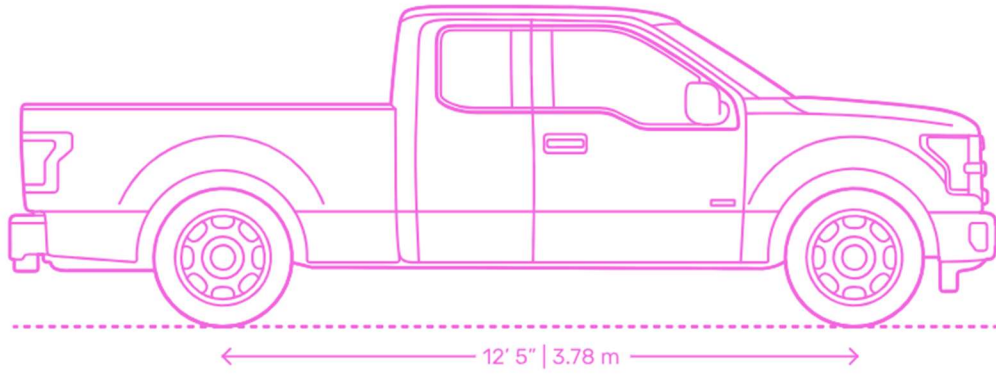

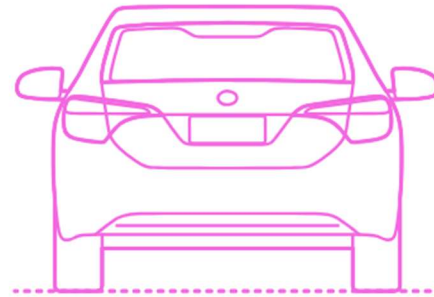
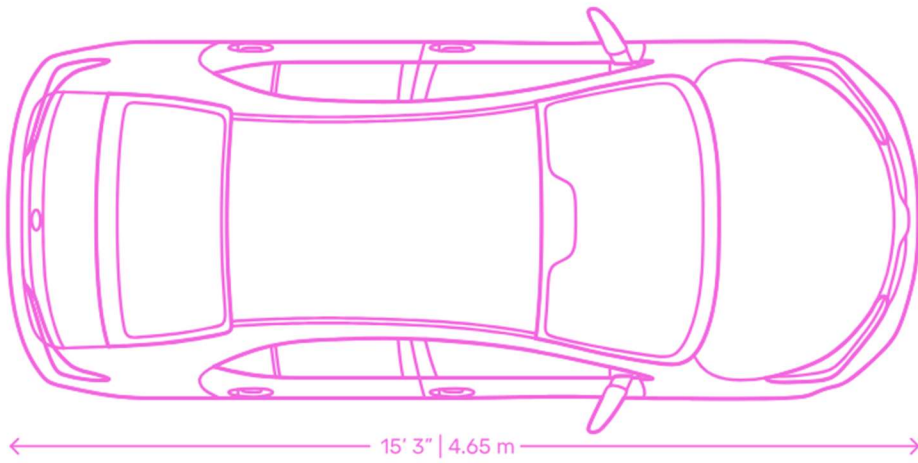
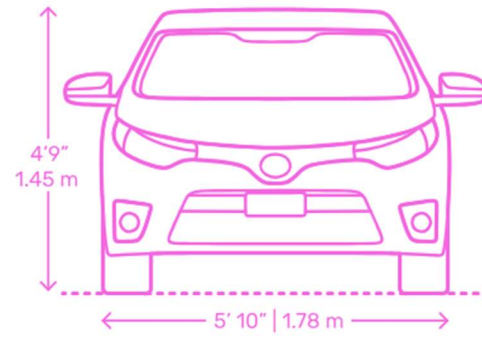
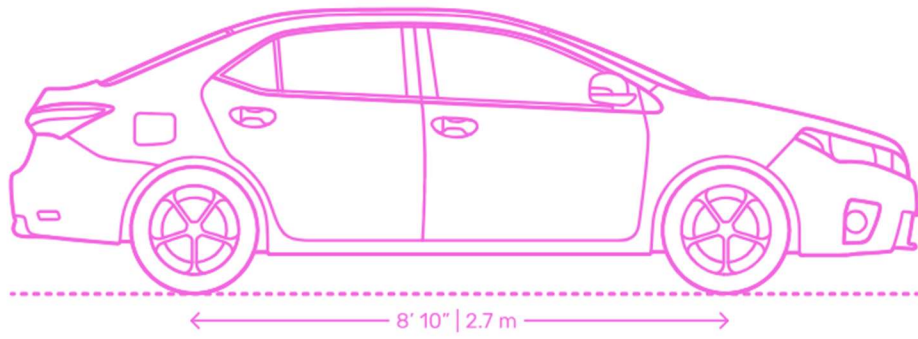

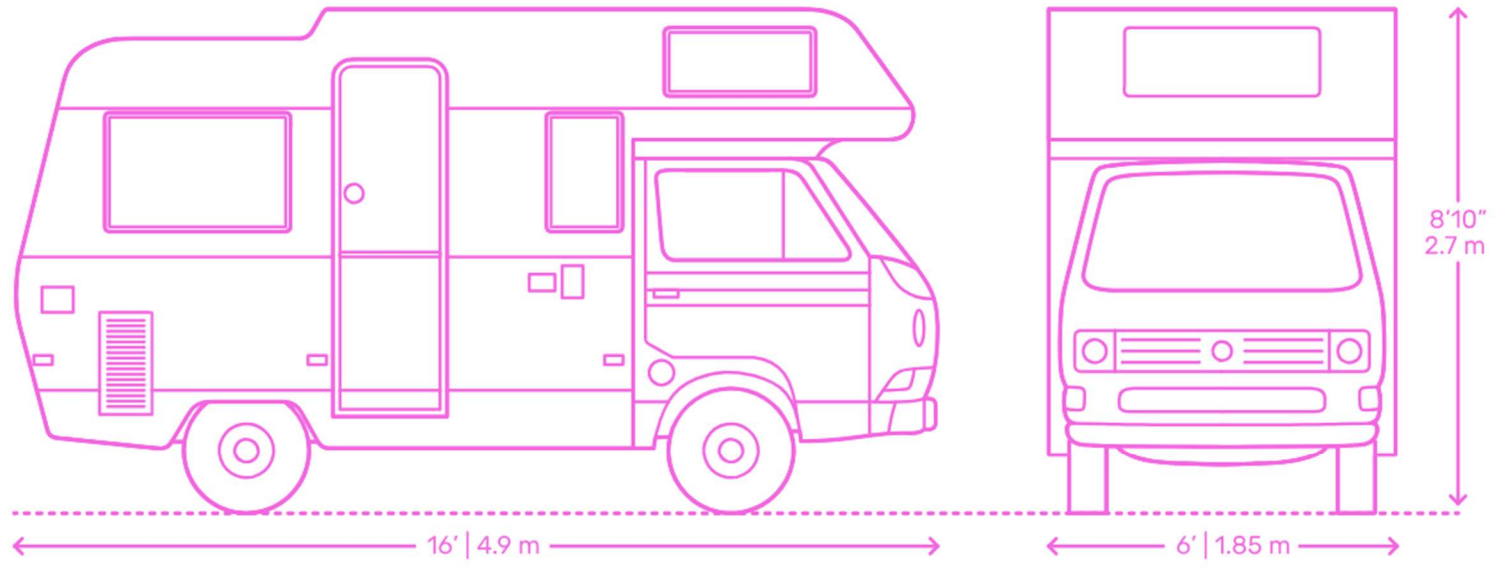

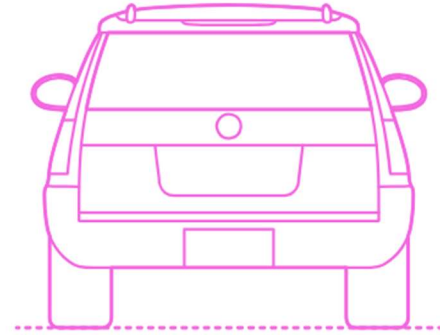
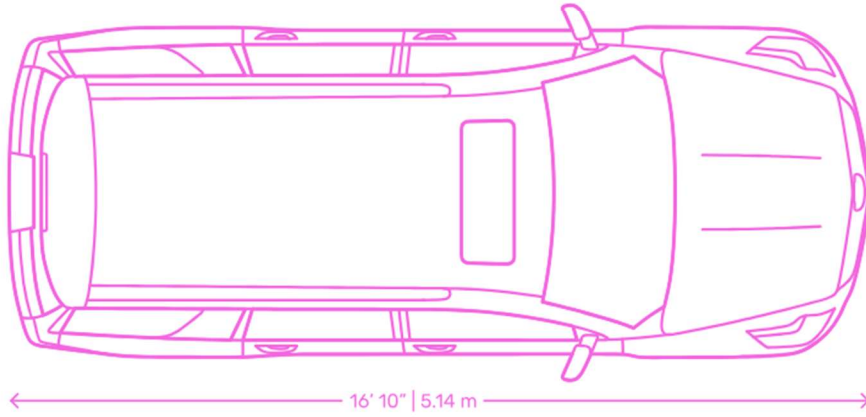
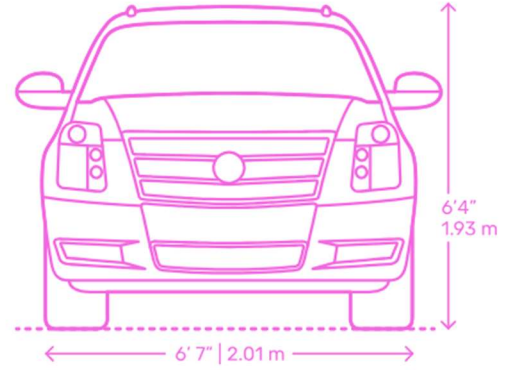
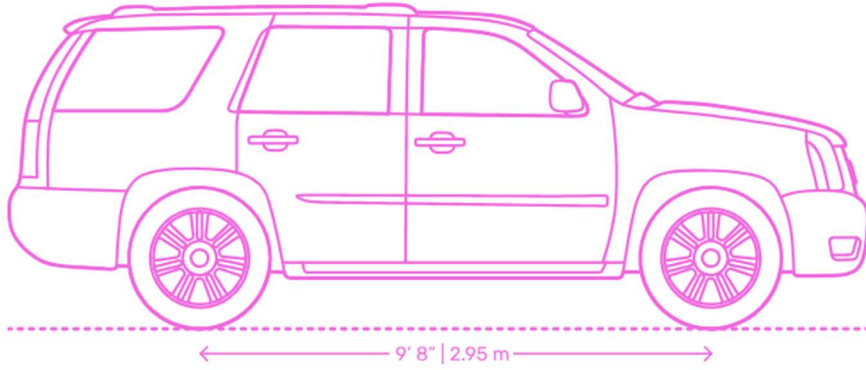

16' BOX DELIVERY TRUCK

CLEARANCES:

- Height: 12'
- Width: 8'
- Length: 24'

