

TOWN OF GLASTONBURY

INVITATION TO BID

<u>BID #</u>	<u>ITEM</u>	<u>DATE &amp; TIME REQUIRED</u>
GL-2010-42	Boiler Replacement Fire CO. 1	April 28, 2010 @ 11:00 a.m.

The Town of Glastonbury is seeking bids for work required to replace the boiler at Glastonbury Fire Company #1, 2825 Main Street, Glastonbury, CT 06033.

Bid forms may be obtained at the Office of the Purchasing Agent, Town Hall, 2155 Main Street, Glastonbury, Connecticut 06033 (second level) or on the Town's website at [www.glastonbury-ct.gov](http://www.glastonbury-ct.gov).

A mandatory pre-bid meeting and site walk through will be held at the Glastonbury Fire Company #1, 2825 Main Street Glastonbury, Connecticut 06033 on April 15, 2010 at 9:00 a.m.. All bidders must attend in order for their bid to be considered. As this work is partially funded by the American Recovery and Reinvestment Act funds, (ARRA) contractors shall comply with Davis Bacon wage rates and the Buy American Act as required by ARRA. Certified payrolls will be required bi-weekly. Sealed proposals must be accompanied with Bid Security. A Bid Security shall be issued payable to the "Town of Glastonbury" in the form of a certified check or Bid Bond in an amount not less than 10% of the total amount of the base bid. The Bid Bond must be issued by a surety company licensed in the State of Connecticut. Cashier's checks will not be accepted.

The Town reserves the right to waive informalities or reject any part of, or the entire bid, when said action is deemed to be in the best interest of the Town. All Sealed Bids must be submitted to the Office of the Purchasing Agent no later than the time and date indicated. All bids will be publicly opened and read.

Mary F. Visone  
Purchasing Agent

**Fire Company #1 Boiler Replacement  
TABLE OF CONTENTS**

**BID #GL-2010-42**

TABLE OF CONTENTS

SECTION

Invitation to Bid

Table of Contents

TC - 1

Information for Bidders

IB 1-4

General Construction Specifications

GCS 1-6

Special Conditions

SC 1-4

Davis Bacon Wages

PW 1-9

Bid Proposal

1-3

1. Sealed bids (**one original and one copy**) on the attached Bid Forms will be received at the Office of the Purchasing Agent, Town Hall, 2155 Main Street, Glastonbury, Connecticut, 06033 (second level). At the designated time of opening, they will be publicly opened, read, recorded and placed on file.
2. Whenever it is deemed to be in the best interest of the Town, the Town Manager, Purchasing Agent or designated representative shall waive informalities in any and all bids. The right is reserved to reject any bid, or any part of any bid, when such action is deemed to be in the best interest of the Town of Glastonbury.
3. Bids will be carefully evaluated as to conformance with stated specifications. The award will be based on the basis of bid total cost.
4. The envelope enclosing your bid should be clearly marked by bid number, time of bid opening, and date.
5. Specifications must be submitted complete in every detail and, when requested, samples shall be provided. If a bid involves any exception from stated specifications, they must be clearly noted as exceptions, underlined, and attached to the bid.
6. The Bid Documents contain the provisions required for the requested item. Information obtained from an officer, agent, or employee of the Town or any other person shall not affect the risks or obligations assumed by the Bidder or relieve him/her from fulfilling any of the conditions of the bid.
7. Each Bidder is held responsible for the examination and/or to have acquainted themselves with any conditions at the job site which would affect their work before submitting a bid. Failure to meet these criteria shall not relieve the Bidder of the responsibility of completing the bid without extra cost to the Town of Glastonbury.
8. Any bid may be withdrawn prior to the above-scheduled time for the opening of bids or authorized postponement thereof. Any bid received after the time and the date specified shall not be considered. No Bidder may withdraw a bid within sixty (60) days after the actual date of the opening thereof. Should there be reasons why a bid cannot be awarded within the specified period, the time may be extended by mutual agreement between the Town and the Bidder.
9. Each bid must be accompanied by a bid bond payable to the Town for ten percent (10%) of the total amount of the bid. The bid bond of the successful Bidder will be retained until the payment bond and performance bond have been executed and approved, after which it will be returned. A certified check may be used in lieu of a bid bond. The Town of Glastonbury will not be liable for the accrual of any interest on any certified check submitted. Cashier's checks will not be accepted.
10. A 100% Performance and Payment bond is required of the successful bidder. This bond shall cover all aspects of the specification and shall be delivered to the Purchasing Agent prior to the issuance of a purchase order. The Performance and Payment Bond will be returned upon the delivery and acceptance of the bid items.
11. The Bidder agrees and warrants that in the submission of this sealed Bid, they will not discriminate or permit discrimination against any person or group of persons on the grounds of race, color, religion, national origin, sex, or physical disability including, but not limited to blindness, unless it is shown by such Bidder that such disability prevents performance of that which must be done to successfully fulfill the terms of this sealed Bid or in any manner which is prohibited by the laws of the United States or the State of Connecticut: and further agrees to provide the Human Relations Commission



with such information requested by the Commission concerning the employment practices and procedures of the Bidder. An Affirmative Action Statement will be required by the successful Bidder.

12. Bidder agrees to comply with all of the latest Federal and State Safety Standards and Regulations and certifies that all work required in this bid will conform to and comply with said standards and regulations. Bidder further agrees to indemnify and hold harmless the Town for all damages assessed against the Town as a result of Bidder's failure to comply with said standards and/or regulations.
13. All correspondence regarding any purchase made by the Town of Glastonbury shall reference the Town's purchase order number. Each shipping container shall clearly indicate both Town purchase order number and item number.
14. Bidder is required to review the Town of Glastonbury Code of Ethics adopted July 8, 2003 and effective August 1, 2003. Bidder shall acknowledge that they have reviewed the document in the area provided on the bid/proposal response page (BP). The selected Bidder will also be required to complete and sign an Acknowledgement Form prior to award. The Code of Ethics and the Consultant Acknowledgement Form can be accessed at the Town of Glastonbury website at [www.glastonbury-ct.gov](http://www.glastonbury-ct.gov). Upon entering the website click on **General Information**, then **Bids and Quotes** which will bring you to the links for the Code of Ethics and the Consultant Acknowledgement Form. If the Bidder does not have access to the internet, a copy of these documents can be obtained through the Purchasing Department at the address listed within this bid/proposal.
15. Any bidder, in order to be considered, shall be engaged primarily in the business of replacing gas fired boilers with a minimum of five (5) years experience and have a valid contractor's license in the State of Connecticut. Each Bidder shall submit a list of similar projects completed within the last three years. In order to be eligible for consideration, the Bidder must have successfully completed a minimum of five (5) similar projects within the last three (3) years. Please provide project name and contact information for project coordinator (name, title, address, phone number). Please also provide contract value.
16. **Non-Resident Contractors:**

The Town is required to report names of non-resident (out-of-State) contractors to the State of Connecticut, Department of Revenue Services (DRS) to ensure that Employment Taxes and other applicable taxes are being paid by Contractors. **Upon award, all non-resident contractors must furnish a five percent (5%) sales tax guarantee bond (State Form AU-766) or a cash bond for five percent (5%) of the total contract price (State Form AU-72) to DRS even though this project is exempt from most sales and use taxes.**

See State Notice to Non-Resident Contractors SN 2005 (12). If the above bond is not provided, the Town is required to withhold five percent (5%) from the contractor's payments and forward it to the State DRS.

The Contractor must promptly furnish to the Town a copy of the Certificate of Compliance issued by the State DRS.
17. Bidder shall include on a sheet(s) attached to its proposal a complete disclosure of all past and pending mediation, arbitration and litigation cases that the bidder or its principals (regardless of their place of employment) have been involved in for the most recent five years. Please include a



statement of the issues in dispute and their resolution. Acceptability of Bidder based upon this disclosure shall lie solely with the Town.

18. Bidder or its principals, regardless of their place of employment, shall not have been convicted of, nor entered any plea of guilty, or nolo contendere, or otherwise have been found civilly liable or criminally responsible for any criminal offense or civil action. Bidder shall not be in violation of any State or local ethics standards or other offenses arising out of the submission of bids or proposals, or performance of work on public works projects or contracts.
19. Municipal construction projects are exempt from Federal Excise Taxes, as well as, State of Connecticut Sales, Use and Service Taxes and should not be include in the Bidder's proposal.
20. After award of Contract, Owner will require the Contractor's schedule of Values, which shall be submitted at the preconstruction meeting. The Schedule of Values must accurately reflect job costs and include a complete breakdown of material and labor costs.
21. BUY AMERICAN REQUIREMENT

It is anticipated funds for this project will be provided through a grant which requires that all bidders comply with the American Recovery and Reinvestment Act of 2009, Public Law 111-5. Section 1605 of the Recovery Act (Buy American) states:

Use of American Iron, Steel and Manufactured Goods.

(a) None of the funds appropriated or otherwise made available by this Act may be used for a project for the construction, alteration, maintenance, or repair of a public building or public work unless all of the iron, steel, and manufactured goods used in the project are produced in the United States.

(b) Subsection (a) shall not apply in any case or category of cases in which the head of the Federal department or agency involved finds that—

(1) applying subsection (a) would be inconsistent with the public interest;

(2) iron, steel, and the relevant manufactured goods are not produced in the United States in sufficient and reasonably available quantities and of a satisfactory quality; or

(3) inclusion of iron, steel, and manufactured goods produced in the United States will increase the cost of the overall project by more than 25 percent.

(c) If the head of a Federal department or agency determines that it is necessary to waive the application of subsection (a) based on a finding under subsection (b), the head of the department or agency shall publish in the Federal Register a detailed written justification as to why the provision is being waived.

(d) This section shall be applied in a manner consistent with United States obligations under international agreements.

All prospective bidders must be able to prove that their products comply with this act. Bidders shall include documentation with their bid response to support the above requirement.

22. APPLICABLE LAWS, FEDERAL LABOR STANDARD PROVISIONS AND REGULATIONS

All provisions of all applicable Federal Davis Bacon Labor Standards must be complied with under this Contract.

**Section 1606 of the Recovery Act Wage Rate Requirements provide:**

Notwithstanding any other provision of law and in a manner consistent with other provisions in this Act, all laborers and mechanics employed by contractors and subcontractors on projects funded directly by or assisted in whole or in part by and through the Federal Government pursuant to this Act shall be paid wages at rates not less than those prevailing on projects of a character similar in the locality as determined by the Secretary of Labor in accordance with subchapter IV of chapter 31 of title 40, United States Code. With respect to the labor standards specified in this section, the Secretary of Labor shall have the authority and functions set forth in Reorganization Plan Numbered 14 of 1950 (64 Stat. 1267; 5 U.S.C. App.) and section 3145 of title 40, United States Code.

The execution of the Contract by the Bidder binds it to all applicable Federal Davis Bacon Labor Laws and Regulations. See below for Davis Bacon Wage Determinations.

All other statutory laws, to the extent they are required to be incorporated into a contract by statute, are hereby deemed fully incorporated herein and in the Contract.

Violation of Davis Bacon Wage Law requirements may cause Contract to be terminated and Owner reserves all its rights if such termination is required.

23. For technical questions regarding this Bid, please contact David Sacchitella, Buildings Superintendent, at (860) 652-7706, [dave.sacchitella@glastonbury-ct.gov](mailto:dave.sacchitella@glastonbury-ct.gov) . For administrative questions regarding this Bid, please contact Mary F. Visone, Purchasing Agent at (860) 652-7589. **The request must be received at least five (5) business days prior to the advertised response deadline. All questions, answers, and/or addenda, as applicable, will be posted on the Town's website at [www.glastonbury-ct.gov](http://www.glastonbury-ct.gov) (Upon entering the website click on Bids & RFPs). It is the respondent's responsibility to check the website for addenda prior to submission of any proposal.**

**Failure to comply with general rules may result in disqualification of the Bidder.**



**01.00 WORKMANSHIP, MATERIALS AND EMPLOYEES**

- 01.01 Wherever in this contract the word "Engineer" is used, it shall be understood as referring to the Director of Facilities of the Town of Glastonbury acting personally or through any assistants duly authorized.
- 01.02 The entire work described herein shall be completed in accordance with the plans and specifications to the full intent and meaning of the same. Unless otherwise specified, all materials incorporated in the permanent work shall be new, and both workmanship and material shall be of good quality. The Contractor shall, if required, furnish satisfactory evidence as to the kind and quality of materials.
- 01.03 The wording "furnish", "install", "construct", "furnish and install", or any similar terms, unless specifically noted to the contrary, shall include all labor, materials, water, tools, equipment, light, power, transportation, and any other services required for the completion of the work.
- 01.04 The Contractor shall at all times enforce strict discipline and good order among his employees, and shall seek to avoid employing on the work any unfit person or anyone not skilled in the work assigned to him.

**02.00 SUPERINTENDENT**

- 02.01 The Contractor shall keep on the work during its progress, in the absence of the Contractor, a competent Superintendent. The Superintendent shall be acceptable to the Engineer and shall fully represent the Contractor. All directions given to the Superintendent shall be binding as if given to the Contractor.

**03.00 PRECONSTRUCTION MEETING**

- 03.01 A Preconstruction Meeting will be held with the Engineer, Contractor, and any other interested parties prior to commencing any work. The Engineer shall arrange the meeting based on a mutually convenient time.

**04.00 PERMITS**

- 04.01 All permits, licenses, and fees required for the performance of the Contract work shall be secured and paid for by the Contractor. The local building permit fees will be waived.

**05.00 PROPERTY ACCESS**

- 05.01 The Contractor shall take all proper precautions to protect from injury or unnecessary interference, and provide proper means of access to abutting property where the existing access is cut off by the Contractor.
- 05.02 The Contractor shall take all proper precautions to protect persons from injury or unnecessary inconvenience and leave an unobstructed way along the public and private places for travelers, vehicles, and access to hydrants.
- 05.03 The Contractor shall make arrangements with the adjacent property owners for such trespass as he may reasonably anticipate in the performance of the work. All such arrangements shall be reported, in writing, to the Engineer.



**06.00 PROTECTION OF THE PUBLIC AND OF WORK AND PROPERTY**

- 06.01 The Contractor shall continuously maintain adequate protection of all work from damage, and shall take all reasonable precautions to protect the Town from injury or loss arising in connection with the Contract.
- 06.02 The Contractor shall adequately protect adjacent private and public property as provided by law and the Contract Documents.
- 06.03 The Contractor shall make good any damage, injury, or loss of work and to the property of the Town resulting from lack of reasonable protective precautions.
- 06.04 The Town buildings involved will be occupied and fully operational. The Contractor may be required to adjust his work schedule should the work have an adverse impact on operations. There will be no modification of the bid price should a schedule adjustment be required.

**07.00 EXISTING IMPROVEMENTS**

- 07.01 The Contractor shall conduct his work so as to minimize damage to existing improvements designated to remain. Except where specifically stated otherwise in the specifications, drawings, or as directed by the Engineer, it will be the responsibility of the Contractor to restore to their original condition, as near as practical, all improvements on public or private property. This shall include:
- a. Property within and adjacent to the work area such as shrubs, walks, driveways, fences, etc.
  - b. Utility mains, ducts, poles, and services. The Contractor is hereby notified that utilities, if/where shown on the plans, are at approximate locations. These locations are subject to possible errors in the source of information and errors in transcription. The Contractor shall make certain of the exact location of all mains, ducts, poles, and services prior to excavation.

**08.00 SEPARATE CONTRACTS**

- 08.01 The Engineer reserves the right to let other contracts in connection with this work. The Contractor shall afford other contractors reasonable opportunity for the introduction and storage of their materials and the execution of their work, and shall properly connect and coordinate his work with theirs. Wherever work being done by the Town of Glastonbury forces or by other contractors is contiguous to work covered by this Contract, the respective rights of the various interests involved shall be established by the Engineer to secure the completion of the various portions of the work.

**09.00 INSPECTION OF WORK**

- 09.01 The Town shall provide sufficient personnel for the inspection of the work.
- 09.02 The Engineer shall at all times have access to the work whenever it is in preparation or progress, and the Contractor shall provide proper facilities for such access and for inspection.

09.03 If the specifications or the Engineer's instructions require any work to be specially tested or approved, the Contractor shall give the Engineer timely notice of its readiness for inspection and, if the inspection is by another authority other than the Engineer, of the date fixed for such inspection. Inspections by the Engineer shall be made promptly. If any work should be covered up without approval or consent of the Engineer, it must, if required by the Engineer, be uncovered for examination and properly restored at the Contractor's expense.

09.04 Re-inspection of any work may be ordered by the Engineer. If such work is found to be in accordance with the Contract Documents, the Town shall pay the cost of re-inspection and replacement. If such work is not in accordance with the Contract Documents, the Contractor shall pay such cost.

**10.00 RIGHT TO INCREASE OR DECREASE WORK**

10.01 The Town shall have the right to increase or decrease the amount of work herein specified as may be required.

**11.00 RIGHT OF ENGINEER TO STOP WORK FOR WEATHER CONDITIONS**

11.01 Should the work, in the opinion of the Engineer, be in danger by reason of inclemency of weather, or could not be finished in time to prevent such danger, the Contractor shall cease operations upon order of the Engineer, and shall not resume them until ordered to do so by the Engineer when the weather conditions are favorable. The Contractor shall, upon such orders, discontinue work, remove all materials or appliances for or in use upon the work, and place the premises in proper condition for use by the public during the time the work is suspended as herein provided, without cost to the Town.

**12.00 CONTRACTOR TO BE RESPONSIBLE FOR IMPERFECT WORK OR MATERIALS**

12.01 Any faithful work or imperfect material that may be discovered before the acceptance and the payment of the work shall be corrected upon the order of the Engineer. The acceptance and payment of the work does not in any manner relieve the Contractor of his obligation to construct work in the proper manner and the use of materials herein specified.

**13.00 TOWN MAY NOTIFY CONTRACTOR IF WORK IS NOT CARRIED ON SATISFACTORILY**

13.01 If, in the opinion of the Engineer, the Contractor is not proceeding with the work at a sufficient rate of progress so as to finish in the time specified, or has abandoned said work, or is not complying with the terms and stipulations or the Contract and specifications, the Engineer may serve notice on the Contractor to adopt such methods as will ensure the completion of the work in the time specified.

13.02 If, within five days after the Engineer has notified the Contractor that his work is not being carried on satisfactorily as before mentioned, the Engineer shall have the right to annul the Contract and manage the work under the direction of the Engineer, or re-let, for the very best interest of the Town as a new contract, the work under said new Contract shall be considered the responsibility of the defaulting Contractor.

13.03 Additional costs incurred over and above the original Contract shall be borne by the Performance Bond.



**14.00 DEDUCTIONS FOR UNCORRECTED WORK**

- 14.01 If the Engineer deems it inexpedient to correct work that has been damaged or that was not done in accordance with the Contract, an equitable deduction from the Contract price shall be made there for.
- 14.02 The Contractor shall promptly remove from the premises all materials condemned by the Engineer as failing to meet Contract requirements, whether incorporated in the work or not, and the Contractor shall promptly replace and re-execute his own work in accordance with the Contract and without expense to the Town, and shall bear the expense of making good all work by other contractors destroyed or damaged by such removal or replacement.
- 14.03 If the Contractor does not remove such condemned work and materials as promptly as possible after written notice, the Engineer may remove them and store the materials at the expense of the Contractor.

**15.00 CLEANING UP**

- 15.01 The Contractor must remove all debris of every description as the work progresses and leave the surroundings in a neat and orderly condition to the satisfaction of the Engineer.
- 15.02 Upon completion, and before acceptance and final payment, the Contractor shall remove from the site all equipment, forms, surplus material, rubbish and miscellaneous debris and leave the site in a neat and presentable condition.

**16.00 ROYALTIES AND PATENTS**

- 16.01 The Contractor shall pay all royalties and license fees. He shall defend all suits or claims for infringement of any patent rights and shall save the Town of Glastonbury harmless from loss on account hereof, except that the Town of Glastonbury shall be responsible for all such loss when a particular manufacturer, product, or process is specified by the Town of Glastonbury.

**17.00 ERRORS OR CONFLICT IN DRAWINGS AND SPECIFICATIONS**

- 17.01 The Contractor shall immediately notify the Owner/Engineer should he find any errors or conflicts in the contract documents. The Owner/Engineer shall render his interpretation or instruction in writing on the items as soon as possible.
- 17.02 Any work undertaken by the Contractor containing possible errors or conflicts will be done at his own risk unless he has received prior written approval from the Owner/Engineer.
- 17.03 The Contractor shall be responsible for estimating and supplying all quantities, and where clarification or additional information is required, a request in writing to the Owner/Engineer shall be made. No extra charge or compensation will be allowed the Contractor unless there is a change in scope or dimension of the project resulting in need for extra material, equipment and/or labor. Said differences are to be handled under Article 18.

**18.00 EXTRA WORK AND EXTRA COST**



- 18.01 The Owner, without invalidating the contract documents, may order extra work or make changes by altering, adding to or deducting from the work, the contract price being adjusted accordingly. All such work shall be executed under the conditions of the original contract except that any claim of extension of time caused thereby shall be adjusted at the time of ordering the change.
- 18.02 No extra work or change shall be performed unless in pursuance of a written order from the Owner/Engineer, with the agreed price prior to the commencement of the work, and no claim for an addition to the contract price shall be valid unless so ordered.
- 18.03 The value of any such work or change shall be determined, in one or more of the following ways:
- a) By estimate and acceptance on a lump sum.
  - b) By unit prices named in the contract or subsequently agreed upon.
  - c) By cost and percentage or by cost and a final fee.

**19.00 SUBSTITUTIONS**

- 19.01 The Contractor shall use materials as specified unless material list is of an open nature. Material other than specified will be permitted only after written application, including four (4) copies of specifications, is made by the Contractor and written approval received from the Engineer or Owner.

The material installed in the job site shall be new and of the quality specified.

The manufacturer's recommendation shall be followed for the installation of all equipment.

**20.00 PRODUCT SUBMITTALS**

- 20.01 Prior to ordering materials, the Contractor shall submit submittals as specified in the detailed specification sections. Three (3) copies of the submittals shall be forwarded to the Engineer for review and approval.
- 20.02 Submittals shall indicate specification Section for each product. Submittals not containing all the required information shall be returned to the contractor for re-submittal.

**21.00 OWNER'S ACCEPTANCE**

- 21.01 Within seven (7) days of the Contractor's notification that the installation is substantially complete, the Owner's authorized representative shall inspect the installation. The Owner, with the Contractor, shall take necessary steps to inspect the installation. Upon completion of the inspection, the Owner or the Owner's authorized representative may either accept the work outright or prepare a "Punch List" that upon completion by the Contractor and acceptance by the Owner will signify final acceptance provided that all other applicable terms and provisions of the Contract have been completed to the Owner's satisfaction.

**22.00 RESPONSIBILITY FOR MAINTENANCE**

- 22.01 It will be the Contractor's responsibility to maintain the work as specified in the detailed specifications during the warranty period.

**23.00 SERVICE BY THE CONTRACTOR**

23.01 The Contractor shall maintain the work as specified during the warranty period.

**24.00 WARRANTY**

24.01 The guarantee shall be as specified in the respective sections of the specification.

24.02 The Contractor shall be responsible for the repair and/or replacement of all defective work and materials. All repair work shall be completed in a timely fashion.

24.04 Should the Contractor not respond promptly, the Owner may take any action he deems necessary to repair the defect and prevent further damage to his property, including the hiring of another contractor, or the repairing of such a defect with material supplied by the Contractor. In this event, the Contractor shall be liable for expenses incurred and property damages suffered by the Owner.

**01.00 NOTICE TO CONTRACTOR**

- 01.01 Intent of Contract: The intent of the Contract is to prescribe a complete work or improvement which the Contractor undertakes to do, in full compliance with the specifications, plans, special provisions, proposal and Contract. The Contractor shall perform all work in close conformity with the plans or as modified by written orders, including the furnishing of all materials, supplies, transportation, labor, and all other things necessary to the satisfactory prosecution and completion of the project.

The scope of the work shall include all labor, materials and equipment needed to provide and install the boiler replacement roof described in these plans and specifications at the Glastonbury Fire Company #1, 2815 Main Street, Glastonbury, CT 06033.

**02.00 COMMUNICATIONS**

- 02.01 All notices, demands, requests, instructions, approvals, proposals, and claims must be in writing.
- 02.02 Any notice to, or demand upon, the Contractor shall be sufficiently given if delivered at the office of the Contractor stated on the signature page of the Agreement (or at such other office as the Contractor may, from time to time, designate) in a sealed, postage-prepaid envelope or delivered with charges prepaid to any telegraph company for transmission, in each case addressed to such office.
- 02.03 All papers required to be delivered to the Town shall, unless otherwise specified in writing to the Contractor, be delivered to the Building Superintendent, 2143 Main Street, Glastonbury, CT 06033, and any notice to, or demand upon, the Town shall be delivered at the above address in a sealed, postage-prepaid envelope or delivered with charges prepaid to any telegraph company for transmission, in each case addressed to such office or to such other representatives of the Town, or to such other address as the Town may subsequently specify in writing to the Contractor for such purpose.
- 02.04 Any such notice shall be deemed to have been given as of the time of actual delivery or, in case of mailing, when the same should have been received in due course of post or, in the case of telegrams, at the time of actual receipt, as the case may be.

**03.00 INSURANCE**

The Bidder shall, at its own expense and cost, obtain and keep in force during the entire duration of the Project or Work the following insurance coverage covering the Bidder and all of its agents, employees and sub-contractors and other providers of services and shall name the **Town its employees and agents as an Additional Insured** on a primary and non-contributory basis to the Bidders Commercial General Liability and Automobile Liability policies. **These requirements shall be clearly stated in the remarks section on the Bidders Certificate of Insurance.** Insurance shall be written with Carriers approved in the State of Connecticut and with a minimum Best's Rating of A-. In addition, all Carriers are subject to approval by the Town. Minimum Limits and requirements are stated below:

- 1) Worker's Compensation Insurance:



- Statutory Coverage
- Employer's Liability
- \$100,000 each accident/\$500,000 disease-policy limit/\$100,000 disease each employee

2) Commercial General Liability:

- Including Premises & Operations, Products and Completed Operations, Personal and Advertising Injury, Contractual Liability and Independent Contractors.
- Limits of Liability for Bodily Injury and Property Damage  
Each Occurrence \$1,000,000  
Aggregate \$2,000,000 (The Aggregate Limit shall apply separately to each job.)
- A Waiver of Subrogation shall be provided

3) Automobile Insurance:

- Including all owned, hired, borrowed and non-owned vehicles
- Limit of Liability for Bodily Injury and Property Damage:  
Per Accident \$1,000,000

The Bidder shall direct its Insurer to provide a Certificate of Insurance to the Town before any work is performed. The Certificate shall specify that the Town shall receive 30 days advance written notice of cancellation or non-renewal. The Certificate shall evidence all required coverage including the Additional Insured and Waiver of Subrogation. The Bidder shall provide the Town copies of any such policies upon request.

**INDEMNIFICATION**

To the fullest extent permitted by law, the Bidder shall indemnify and hold harmless the Town and its consultants, agents, and employees from and against all claims, damages, losses and expenses, direct, indirect or consequential (including but not limited to fees and charges of engineers, attorneys and other professionals and court and arbitration costs) arising out of or resulting from the performance of the Bidder's work, provided that such claim, damage, loss or expense is caused in whole or in part by any negligent act or omission by the Bidder, or breach of its obligations herein or by any person or organization directly or indirectly employed or engaged by the Bidder to perform or furnish either of the services, or anyone for whose acts the Bidder may be liable, regardless of whether or not it is caused in part by a party indemnified hereunder.

**04.00 WORK BY OTHERS**

- 04.01 Private utilities, contractors, developers or other parties may be expected to be working within the Contract area during this Contract. It shall be the responsibility of the contractor to coordinate his work with the work being done by others in order that the construction shall proceed in an efficient and logical manner. The Contractor shall have no claim or claims whatever against the Town, the Engineer, or other parties due to delays or other reasons caused by the work by others or his failure to coordinate such work.

**05.00 CONTRACTOR'S WORK AND STORAGE AREA**

- 05.01 The Contractor shall contact the Town to determine if any specific locations will be designated, or gain its approval prior to using any area for storage of equipment, materials and trailers during

the period of this Contract. The Contractor shall confine his work/storage area to the limits as designated or approved and shall be responsible for the security of the work/storage area. Upon completion of the Contract, the Contractor shall remove all equipment and materials, except as otherwise specified, and restore the site to its original condition as approved by the Engineer and at no cost to the Town.

**06.00 DISPOSAL AREA**

06.01 The Tryon Street Bulky Waste Facility will be available to the Contractor, at no charge, for disposal of materials that are accepted at that facility. No materials containing lead-based paint of any level shall be dumped at the Tryon Street facility. The Contractor is required to obtain a disposal area for all other unsuitable or surplus materials at no cost to the Town. Contractors are encouraged to recycle all applicable materials from this project.

**07.00 DUST CONTROL**

07.01 During the progress of the work, the Contractor shall conduct his operations and maintain the area of his activities so as to minimize the creation and dispersion of dust. If the Engineer decides that it is necessary to use water or calcium chloride for more effective dust control, the Contractor shall furnish and spread the material, as directed, without additional compensation.

**08.00 PROTECTION OF EXISTING UTILITIES**

08.01 Before starting any excavation, the Contractor shall submit to the Engineer plans or details showing the proposed method the Contractor will use to support and protect all existing utilities during construction. The furnishing of such plans and details shall not serve to relieve the Contractor of any responsibility for the proper conduct of the work.

08.02 There will be no extra payment for submitting plans or details for supporting and protecting all existing utilities during construction.

**09.00 TIME FOR COMPLETION/NOTICE TO PROCEED**

09.01 Within ten (10) calendar days after the date of the Notice of Award, the Contractor must provide the appropriate insurance certificates to the Town Purchasing Agent and shall be issued a Notice to Proceed and a Purchase Order prior to initiating any work on the project.

09.02 Work shall commence after the last day of school as described in the Notice to Proceed/Purchase Order.

09.03 After the work has begun, it will continue in an orderly fashion and shall be fully completed by August 18, 2010. The Engineer reserves the right to extend the contract an additional thirty (30) days by mutual written agreement.

**10.00 MEASUREMENT AND PAYMENT**

10.01 All direct, indirect, or incidental costs of work and/or services required by these specifications shall be included in the Lump Sum price.

10.01.1 Monthly progress payments will be made, based on the approved Schedule of Values, for work that has progressed in accordance with the contract documents, subject to a deduction of five

percent (5%) of the amount of the application for payment to be retained by the Owner until completion of the entire contract in an acceptable manner and two and one half percent (2.5%) until the applicable one year warranty period has expired and all required inspections have been completed and results have been submitted and approved by the Engineer.

**11.00 COMPLIANCE WITH APPLICABLE FEDERAL, STATE AND LOCAL REQUIREMENTS**

- 11.01 This award of bid is subject to the conformance of the Contractor to all Federal, State, and Local laws, statutes, regulations, ordinances or other requirements that are applicable to the type of work contained in these specifications.











PLASTERER.....\$ 32.18 20.44

-----  
 CARP0024-012 05/04/2009

Rates Fringes

CARPENTER (Including Drywall  
 Hanging, Acoustical Ceiling  
 Installation, Soft  
 Floor/Carpet Laying, Metal  
 Stud Installation, Form Work  
 and Scaffold Building).....\$ 29.00 17.80

-----  
 CARP0024-013 05/04/2009

Rates Fringes

MILLWRIGHT.....\$ 29.75 17.80

-----  
 ELEC0035-007 06/01/2009

Entire County excluding Berlin, Bristol, Hartland, New Britain,  
 Newington, Plainville and Southington Townships

Rates Fringes

ELECTRICIAN, Including Low  
 Voltage Wiring.....\$ 35.40 19.51

-----  
 ELEC0090-007 06/01/2009

Berlin, Bristol, New Britain, Newington, Plainville,  
 Southington Townships

Rates Fringes

ELECTRICIAN, Including Low  
 Voltage Wiring.....\$ 34.95 19.50

-----  
 ELEC0488-010 06/01/2009

Hartland Township

Rates Fringes

ELECTRICIAN, Including Low  
 Voltage Wiring.....\$ 34.80 19.80

-----  
 \* ELEV0091-001 01/01/2010

Rates Fringes

ELEVATOR MECHANIC.....\$ 43.57 20.035+a+b

a. PAID HOLIDAYS: New Year's Day, Memorial Day, Independence  
 Day, Labor Day, Veterans' Day, Thanksgiving Day, Christmas  
 Day, plus the Friday after Thanksgiving.



b. VACATION: Employer contributes 8% of basic hourly rate for 5 years or more of service or 6% of basic hourly rate for 6 months to 5 years of service as vacation pay credit.

-----  
 ENGI0478-013 04/05/2009

	Rates	Fringes
POWER EQUIPMENT OPERATOR:		
Asphalt Paver.....	\$ 32.01	17.75+a
Asphalt Roller.....	\$ 31.36	17.75+a
Backhoe/Excavator 2 cubic yards and over.....	\$ 33.73	17.75+a
Backhoe/Excavator under 2 cubic yards; Grader/Blade; Rubber Tire		
Backhoe/Excavator.....	\$ 32.99	17.75+a
Bobcat/Skid Loader;		
Forklift.....	\$ 30.53	17.75+a
Bulldozer (Rough Grade Dozer).....	\$ 31.70	17.75+a
Bulldozer Fine Grade.....	\$ 32.99	17.75+a
Concrete Pump.....	\$ 32.01	17.75+a
Crane handling or erecting structural steel or stone...	\$ 34.05	17.75+a+b
Cranes (100 ton capacity & over).....	\$ 33.73	17.75+a+b
Cranes (under 100 ton rated capacity).....	\$ 32.99	17.75+a+b
Earth Roller.....	\$ 28.49	17.75+a
Front End Loader (3 cubic yards up to 7 cubic yards)..	\$ 31.70	17.75+a
Front End Loader (7 cubic yards or over).....	\$ 34.05	17.75+a
Front End Loader (under 3 cubic yards).....	\$ 30.53	17.75+a
Maintenance Engineer/Oiler..	\$ 25.65	17.75+a
Mechanic.....	\$ 30.96	17.75+a
Vibratory Hammer.....	\$ 28.49	17.75+a

a. PAID HOLIDAYS: New Year's Day, Good Friday, Memorial Day, Independence Day, Labor Day, Thanksgiving Day and Christmas Day, provided the employee works 3 days during the week in which the holiday falls, if scheduled, and if scheduled, the working day before and the working day after the holiday.

- b. Crane with boom, including jib, 150 feet - \$1.50 extra .  
 Crane with boom, including jib, 200 feet- \$2.50 extra.  
 Crane with boom, including jib, 250 feet - \$5.00 extra.  
 Crane with boom, including jib, 300 feet - \$7.00 extra.  
 Crane with boom, including jib, 400 feet - \$10.00 extra.

-----  
 IRON0015-006 06/29/2009

	Rates	Fringes
IRONWORKER, ORNAMENTAL, REINFORCING AND STRUCTURAL.....	\$ 32.75	25.08+a

a. PAID HOLIDAY: Labor Day provided employee has been on the payroll for the 5 consecutive work days prior to Labor Day.

LABO0056-010 04/05/2009

	Rates	Fringes
LABORERS		
Common or General.....	\$ 24.25	14.45
Mason Tender-Brick.....	\$ 24.75	14.45
Mason Tender- Cement/Concrete.....	\$ 24.75	14.45
Plaster Tender.....	\$ 24.50	14.45

PAIN0011-012 06/01/2009

	Rates	Fringes
GLAZIER.....	\$ 31.73	14.55+a

a. PAID HOLIDAYS: Labor Day and Christmas Day.

PAIN0011-020 06/01/2009

	Rates	Fringes
PAINTER		
Brush and Roller.....	\$ 28.17	14.55
Drywall Finishing/Taping Only.....	\$ 28.92	14.55
Paperhanger Only.....	\$ 28.67	14.55
Spray Only.....	\$ 31.17	14.55

PLUM0777-006 06/01/2009

	Rates	Fringes
PIPEFITTER, Including HVAC		
Pipe Installation.....	\$ 36.32	21.26

PLUM0777-007 06/01/2009

	Rates	Fringes
PLUMBER, Excluding HVAC Pipe		
Installation.....	\$ 36.32	21.26

\* ROOF0009-005 01/01/2010

	Rates	Fringes
ROOFER		
Composition.....	\$ 31.10	15.31
Slate and Tile.....	\$ 31.60	15.31

\* SFCT0676-002 01/01/2010

	Rates	Fringes
SPRINKLER FITTER (Fire		



Sprinklers).....\$ 40.50 16.85+a

a. PAID HOLIDAYS: Memorial Day, July 4th, Labor Day, Thanksgiving Day and Christmas Day, provided the employee has been in the employment of a contractor 20 working days prior to any such paid holiday.

-----  
SHEE0040-004 07/01/2009

	Rates	Fringes
SHEETMETAL WORKER, Including HVAC Duct Installation.....	\$ 31.57	25.92

-----  
SUCT2009-005 04/15/2009

	Rates	Fringes
ASBESTOS WORKER/HEAT & FROST INSULATOR.....	\$ 24.25	10.76
LABORER: Airtool Operator.....	\$ 17.04	6.90
LABORER: Fence Erector.....	\$ 19.65	7.00
LABORER: Landscape.....	\$ 19.97	2.70
LINE CONSTRUCTION: Groundman....	\$ 10.00	2.17
LINE CONSTRUCTION: Lineman.....	\$ 22.09	6.18
OPERATOR: Asphalt Spreader.....	\$ 25.05	8.90
TILE FINISHER.....	\$ 24.55	0.00

-----  
WELDERS - Receive rate prescribed for craft performing operation to which welding is incidental.  
=====

Unlisted classifications needed for work not included within the scope of the classifications listed may be added after award only as provided in the labor standards contract clauses (29 CFR 5.5(a)(1)(ii)).

-----  
--  
In the listing above, the "SU" designation means that rates listed under the identifier do not reflect collectively bargained wage and fringe benefit rates. Other designations indicate unions whose rates have been determined to be prevailing.  
-----  
--

## WAGE DETERMINATION APPEALS PROCESS

1.) Has there been an initial decision in the matter? This can be:

- \* an existing published wage determination
- \* a survey underlying a wage determination
- \* a Wage and Hour Division letter setting forth a position on a wage determination matter
- \* a conformance (additional classification and rate) ruling

On survey related matters, initial contact, including requests for summaries of surveys, should be with the Wage and Hour Regional Office for the area in which the survey was conducted because those Regional Offices have responsibility for the Davis-Bacon survey program. If the response from this initial contact is not satisfactory, then the process described in 2.) and 3.) should be followed.

With regard to any other matter not yet ripe for the formal process described here, initial contact should be with the Branch of Construction Wage Determinations. Write to:

Branch of Construction Wage Determinations  
Wage and Hour Division  
U.S. Department of Labor  
200 Constitution Avenue, N.W.  
Washington, DC 20210

2.) If the answer to the question in 1.) is yes, then an interested party (those affected by the action) can request review and reconsideration from the Wage and Hour Administrator (See 29 CFR Part 1.8 and 29 CFR Part 7).

Write to:

Wage and Hour Administrator  
U.S. Department of Labor  
200 Constitution Avenue, N.W.  
Washington, DC 20210

The request should be accompanied by a full statement of the interested party's position and by any information (wage payment data, project description, area practice material, etc.) that the requestor considers relevant to the issue.

3.) If the decision of the Administrator is not favorable, an interested

party may appeal directly to the Administrative Review Board  
(formerly the  
Wage Appeals Board). Write to:

Administrative Review Board  
U.S. Department of Labor  
200 Constitution Avenue, N.W.  
Washington, DC 20210

4.) All decisions by the Administrative Review Board are final.

END OF GENERAL DECISION



**Glastonbury Fire Company #1 Boiler Replacement  
LIST OF DRAWINGS**

**BID #GL-2010-42**

- M-1 First Floor Plan-Mechanical
- M-2 Mechanical Schedules, Details and Piping Diagrams

Proposal of \_\_\_\_\_  
(hereinafter called "Bidder"), organized and existing under the laws of the State of \_\_\_\_\_  
\_\_\_\_\_, doing business as \_\_\_\_\_  
\_\_\_\_\_.

To the Town of Glastonbury (hereinafter called "Town").

In compliance with your Invitation to Bid, the Bidder hereby proposes to furnish and/or services as per Bid Number GL-2010-42 in strict accordance with the Bid Documents, within the time set forth therein, and at the prices stated below.

By submission of this bid, the Bidder certifies, and in the case of a joint bid each party thereto certifies as to their own organization that this bid has been arrived at independently without consultation, communication, or agreement as to any matter relating to this bid with any other Bidder or with any competitor.

The Bidder acknowledges receipt of the following Addendum:

Addendum #1 \_\_\_\_\_

Addendum #2 \_\_\_\_\_

Addendum #3 \_\_\_\_\_

**It is the responsibility of the bidder to check the Town's website for any Addendum before submitting the bid.**

**TOTAL BID AMOUNT:**

Furnish and install Boiler Replacement roof for Fire Company #1 as specified in the Plans and Specifications for Bid GL-2010-42 \$ \_\_\_\_\_

**WRITTEN BID AMOUNT:** \$ \_\_\_\_\_  
\_\_\_\_\_

Other Items Required with Submission of Bid Proposal

The following bid checklist describes items required for inclusion with the above-referenced bid proposal package. It is provided for the convenience of the bidders and, therefore, should not be assumed to be a complete list.

- \_\_\_\_\_ Bid Bond (10% of total bid amount).
- \_\_\_\_\_ List of similar projects completed within last three (3) years. A minimum of five (5) are required.
- \_\_\_\_\_ Acknowledgement of Addendums in Bid Proposal (as applicable).
- \_\_\_\_\_ Acknowledgement of Code of Ethics in Bid Proposal.
- \_\_\_\_\_ Sealed bids, one original and one copy.
- \_\_\_\_\_ Disclosure of past and pending mediation, arbitration and litigation cases that the Bidder or its principals have been involved in for the most recent five years (if applicable).
- \_\_\_\_\_ Copy of Bidder's Contractor's License (State of Connecticut).
- \_\_\_\_\_ Proof of compliance with Buy American Act

**It is the responsibility of the Respondent to clearly mark the outside of the bid envelope with the Bid Number, Date and Time of Bid Opening, and it also THE RESPONSIBILITY OF THE BIDDER TO CHECK THE TOWN'S WEBSITE BEFORE SUBMITTING BID FOR ADDENDUMS POSTED PRIOR TO BID OPENING.**



**CODE OF ETHICS**

I/We have reviewed a copy of the Town of Glastonbury's Code of Ethics and agree to submit a Consultant Acknowledgement Form if I/We are selected. Yes \_\_\_\_\_ No \_\_\_\_\_\*

\*Bidder is advised that effective August 1, 2003, the Town of Glastonbury cannot consider any bid or proposal where the Bidder has not agreed to the above statement.

Respectfully submitted:

\_\_\_\_\_  
Type or Print Name of Individual

\_\_\_\_\_  
Doing Business as (Trade Name)

\_\_\_\_\_  
Signature of Individual

\_\_\_\_\_  
Street Address

\_\_\_\_\_  
Title

\_\_\_\_\_  
City, State, Zip Code

\_\_\_\_\_  
Date

\_\_\_\_\_  
Telephone Number/Fax Number

\_\_\_\_\_  
E-Mail Address

\_\_\_\_\_  
SS# or TIN#

(Seal – If bid is by a Corporation)

Attest

SECTION 15010 - GENERAL CONDITIONS FOR MECHANICAL AND ELECTRICAL SYSTEMS

PART 1 - GENERAL

1.1 RELATED DOCUMENTS:

- A. The General provisions of the Contract, including General and Supplementary Conditions, and Division 1, General Requirements apply to the work specified in this Section.
- B. Scope of Work: This Section contains special provisions for Divisions 15 and 16.

1.2 EXAMINATION OF SITE AND DRAWINGS:

- A. Before submitting his bid, Contractor shall visit site with plans and specifications in hand, shall consult with the Engineer and shall become thoroughly familiar with all conditions under which his work will be done since he will be held responsible for any assumptions he may make in regard thereto.
- B. The Contractor shall verify and obtain all necessary dimensions at the building.
- C. Certain present building clearances are available for handling equipment.

1.3 INTENT:

- A. Finished Work: The intent of the specifications and drawings is to call for finished work, completed, tested and ready for operation.
- B. Good Practice: It is not intended that the drawings show every pipe, fitting or minor detail and it is understood that while the drawings must be followed as closely as circumstances will permit, the systems shall be installed according to the intent and meaning of the Contract Documents and in accordance with good practice.
- C. Work under each Section shall include giving written notice to the Town within 15 days after the Award of the Contract of any materials of apparatus believed inadequate or unsuitable or in violation of any laws or codes, or items of work omitted. In the absence of such written notice, it is mutually agreed that work under each Section has included the cost of all required items and labor for the satisfactory functioning of the entire system without extra compensation.
- D. Any apparatus, appliance, material or work not shown on drawings but mentioned in specifications or vice versa, or any incidental accessories necessary to make the work complete and perfect in all respects and ready for operation, even if not particularly specified, shall be furnished and installed by Contractor at no additional cost to the Town.
- E. Prior to receipt of bids, Contractors shall give written notice to Engineer of any materials or apparatus believed inadequate, unsuitable or in violation of laws, ordinances, rules or regulations of authorities having jurisdiction and any necessary items or work omitted. In the absence of such written notice, it is mutually agreed that Contractor has included the cost

**GLASTONBURY FIRE HOUSE  
BOILER REPLACEMENT  
GLASTONBURY, CONNECTICUT**

of all required items in his proposal and that he will be responsible for approved satisfactory functioning of systems without further compensation.

- F. In all cases where apparatus is herein referred to in singular number, it is intended that such reference include as many such items as are required to complete work.
- G. If not otherwise specified or shown on plans, apparatus and materials shall be installed in accordance with manufacturer's published recommendations and instructions and to the complete satisfaction of the Architect.
- H. It is the intent of these specifications for Mechanical and Electrical Contractors and/or their subcontractors or equipment suppliers to furnish all equipment complete with all accessories.

1.4 REGULATIONS:

- A. Codes: All work shall be done in strict accordance with the 2005 Connecticut State Building Code Supplement and the 2009 Amendment, 2005 Connecticut State Fire Safety Code Supplement and the 2009 Amendment, 2003 IBC, 2003 IPC, 2003 IMC, Connecticut Public Health Code, 2006 IECC, 2003 NFPA 101, all applicable NFPA Codes, NEC, UL, NEMA, O.S.H.A., with all requirements of local utility companies and the requirements of all governmental departments having jurisdiction.
- B. Precedence: Requirements of the above shall take precedence over plans and specifications.
- C. Equipment construction standards shall be as follows: Pressure vessels shall be constructed in accordance with the ASME Code, all electrical equipment shall be UL listed and approved and conform to the N.E.C., gas equipment shall be approved by A.G.A. and conform to N.F.P.A. Codes, piping materials, fittings, valves and accessories shall be constructed in accordance with A.S.T.M. and A.N.S.I. standards for class of work involved. All equipment and materials shall be new and of domestic manufacture. All the above codes shall be referenced and dated in the Connecticut Basic Building Code.
- D. Wherever discrepancies occur between above regulations and agencies and contract drawings and specifications, the requirements of above shall take precedence, except that the contract drawings and specifications shall be minimum requirements and that contractors shall advise engineer of any required changes before proceeding with work.

1.5 APPROVED FITTINGS:

- A. No material other than that contained in the "Latest List of Electric Fittings" approved by the Underwriters' Laboratories, Inc., shall be used in any part of the work.  
All wiring, conduit, switches and other material for which label service has been established, shall bear the label of the Underwriters' Laboratories, Inc.

1.6 PERMITS, FEES:

- A. Include all necessary notices, obtain all permits and pay all governmental taxes, fees, and other costs. File all necessary plans, prepare all documents and obtain all necessary approvals of all governmental departments having jurisdiction. Obtain all required Certificates of the Town before request for acceptance and final payment for the work.



**GLASTONBURY FIRE HOUSE  
BOILER REPLACEMENT  
GLASTONBURY, CONNECTICUT**

1.7 DEFINITIONS:

- A. Words "finish" or "finished" refer to all rooms and areas listed in Finished Schedule on Architect's Drawings. All rooms and areas not covered in Schedule, including underground tunnels and areas above ceilings, shall be considered not finished except as otherwise noted.
- B. The word "provide" means to "furnish and install" reference item.

1.8 PROTECTION:

- A. Work under each section shall include protecting the work and materials of all other sections from damage by work or workmen, and shall include making good any and all damage thus caused.
- B. Each section shall be responsible for work and equipment until finally inspected, tested and accepted. Protect work against theft, weather, injury or damage and carefully store material and equipment received on site which is not immediately installed. Close open ends of work with temporary covers or plugs during construction to prevent entry of obstructing materials.
- C. If so specified under the respective section, work may include receiving, unloading, uncrating, storing, protecting, setting in place and connecting up completely of any motor starters, control equipment having mechanical/electrical service connections which may be furnished by Town or furnished under another section. Work under each section shall include exercising special care in handling and protecting equipment and fixtures. Any of the above equipment and fixtures which are missing or damaged by reason of mishandling or failure to protect shall be replaced at no additional cost to the Town.

1.9 EQUIPMENT SUBSTITUTIONS AND DEVIATIONS:

- A. Wherever more than one manufacturer is mentioned in specifications and drawings, any of these named are considered equally acceptable to that on upon which design was based and, providing all requirements are met, insofar as performance, space requirements, noise levels and special accessories or materials are concerned, any of those named may be included in Contractor's bid.
- B. Where Contractor proposes to use an item of equipment which differs from that upon which design was based, which required any redesign of structure, partitions, foundations, piping, wiring or of any other part of Mechanical, Electrical or Architectural Layout, all such redesign, new drawings or detailing required shall be prepared by Contractor at his own expense for approval of Engineer.
- C. Where approved substitutions or deviations require a different quantity, size or arrange of structural supports, wiring, conduit, piping, ductwork, and equipment from that upon which design was based, all additional items required by the systems shall, with the approval of Engineer, be furnished by Contractor at no additional cost to Town.

1.10 ELECTRICAL WORK:

**GLASTONBURY FIRE HOUSE  
BOILER REPLACEMENT  
GLASTONBURY, CONNECTICUT**

- A. The Electrical Section includes all power wiring for all electrical switches, motor starters and unmounted motors, furnished at the job site by other sections or furnished under the Electrical Sections as stated in other sections of the specifications.
- B. The Electrical Section shall install and wire all starters, switches and controls, as specified and/or shown on drawings. This shall include all operating and safety controls. Refer to sections 16000 and 16400 for additional information.
- C. Electrically operated equipment supplied by other sections which will be installed and wired by Electrical Section shall be delivered to him with detailed instructions for their installation and wiring in sufficient time and proper sequence to enable him to meet his work schedule.
- D. Control devices that include mechanical elements, such as float switches, shall be installed by the section furnishing them, but be wired by the Electrical Sections.
- E. Equipment which includes a number of correlated electrical control devices mounted in a single enclosure or on a common base with equipment shall be supplied for installation completely wired as unit with terminal boxes and ample leads and/or terminal strips, ready for electrical wiring.
- F. Electrical Contractor shall furnish local disconnect switch for all equipment and manual motor starter for fractional HP motors.

**1.11 DRAWINGS:**

- A. The mechanical and electrical drawings are intended to supplement each other and are to be considered as a unit which, taken together in conjunction with the specifications, completely describes the work to be done. All drawings shall be checked to verify spaces in which work will be installed. Where headroom or space conditions appear inadequate, notification shall be given to Engineer before proceeding with installation.
- B. The Engineer may without charge, make modifications in the layout as needed to prevent conflict with work of other trades or for proper execution of the work.
- C. Note that the drawings are diagrammatic and indicate the general arrangement of the Mechanical and Electrical Equipment and systems, without showing every detail and fitting.
- D. Where conflicts occur between drawings and specifications or within either, the item or arrangement of better quality, greater quality or highest cost shall be included in Contract price. Engineer shall determine the manner or item with which work shall be installed.
- E. Keep one complete set of all drawings, specifications, shop drawings and addenda on the premises at all times in good condition and available to the Engineer and Town.

**1.12 REVIEWS:**

- A. The materials, workmanship, design and arrangement of all work installed under the Mechanical and Electrical sections shall be subject to the review of the Engineer.

**GLASTONBURY FIRE HOUSE  
BOILER REPLACEMENT  
GLASTONBURY, CONNECTICUT**

- B. Where any specific material process or method of construction or manufactured article is specified by name or by reference to the catalog number of a manufacturer, the specifications are to be used as a guide and not intended to take precedence over the basic duty and performance specified or noted on drawings. In all cases, the specific characteristics of the equipment offered for approval, shall be indicated on the shop drawings.
- C. All component parts of each item of equipment or device shall bear the manufacturer's nameplate, giving name of manufacturer, description, size, type, serial or model number, electrical characteristics, etc. in order to facilitate maintenance or replacement. The nameplate of a subcontractor or distributor will not be acceptable.
- D. If material or equipment is installed before it is reviewed, it shall be removed and replaced at no extra charge to the Town if, in the opinion of the Engineer, the material or equipment does not meet the intent of the drawings and specifications.

**1.13 SHOP DRAWINGS:**

- A. Contractor shall submit for review seven (7) copies each of shop drawings of all new equipment, materials, piping, lighting fixtures, devices, panels and wiring. Engineer's review of shop drawings must be completed before any equipment is purchased or any work is installed.
- B. Shop drawings shall consist of manufacturer's certified scale drawings, cuts or catalog, including descriptive literature and complete certified characteristics of equipment, showing dimensions, capacity, code requirements, motor and drive testing as indicated on the drawings or specifications. Also, sheet metal fabrication drawings drawn to scale of 1/4" to the foot or larger.
- C. Certified performance curves for all pumping equipment shall be submitted for review.
- D. Samples, drawings, specifications, catalogs, etc. submitted for review shall be properly labeled indicating specific service for which material or equipment is to be used, division and article number of specifications governing Contractor's name and name of job.
- E. Catalog, pamphlets or other documents submitted to describe items on which review is being requested, shall be specific and identification in catalog, pamphlet, etc. of item submitted shall be clearly made in ink. Data of a general nature will not be accepted.
- F. Review stamp rendered on shop drawings shall not be considered as a guarantee of measurements of building conditions.

Where drawings are reviewed, said review does not mean that drawings have been checked in detail. Said review does not in any way relieve the Contractor from his responsibility or necessity of furnishing material or performing work as required by the Contract Drawings and Specifications.

- G. Failure by the Contractor to submit shop drawings in ample time for checking shall not entitle him to an extension of Contract and no claim for extension by reason of such default will be allowed.



**GLASTONBURY FIRE HOUSE  
BOILER REPLACEMENT  
GLASTONBURY, CONNECTICUT**

- H. Prior to submission to shop drawings, the Contractor shall thoroughly check each shop drawing, reject those not conforming to the specifications and indicate by his signature that the shop drawings submitted in his opinion meet Contract requirements.

1.14 CUTTING AND PATCHING:

- A. All cutting of openings in walls, floors, partitions, etc. must be done by the Electrical and/or Mechanical Contractor as required to install the work including all cutting of existing construction work. Cutting shall be neatly done and limited to the minimum size necessary. Contractor shall patch and restore to its original condition any work disturbed as a result of work under this Contract.

PART 2 - PRODUCTS

2.1 MATERIALS AND WORKMANSHIP:

- A. All materials and apparatus used shall be new, of first class quality and shall be furnished, delivered, erected, connected and finished in every detail. No materials or apparatus used shall be discontinued or about to be discontinued items.
- B. The Engineer shall have the right to reject any part of the work in case material or workmanship is not of satisfactory quality.
- C. Any unacceptable work and material shall be replaced with acceptable work and material at no additional expense to the Town.
- D. In case there is any doubt of the acceptability of any material, submit samples to the Engineer for approval and only definite approval in writing from the Engineer shall be evidence of such approval.
- E. Such approval shall also be subject to the satisfactory installation of the material.
- F. The work in each of these sections shall be constantly under the direction of a competent superintendent who shall be on the premises during such period as the work is in progress. The superintendent shall familiarize himself with the work of all other sections involved insofar as they relate to or in any way affect the work of these sections, and shall coordinate the work.
- G. Unless otherwise noted, all equipment and materials shall be installed and/or applied in accordance with the recommendations of the manufacturer of said equipment, including the performance of any tests recommended by the manufacturer.

2.2 EQUIPMENT VARIATIONS:

- A. In these specifications and on the accompanying drawings, one or more makes of materials, apparatus or appliances have been specified for use in this installation. This has been done for convenience in fixing the standard of workmanship performance of any materials, apparatus or appliance which shall be substituted for those mentioned herein shall also conform to these standards.

**GLASTONBURY FIRE HOUSE  
BOILER REPLACEMENT  
GLASTONBURY, CONNECTICUT**

- B. Where no specified make or material, apparatus or appliance is mentioned, any first class product made by a reputable manufacturer may be used, providing it conforms to the requirements of these specifications and meets the approval of the Engineer.
- C. Refer to Article 15 of the General Conditions of the contract for substitution procedures.
- D. To substitute other makes of materials, apparatus or appliance, than those mentioned under the mechanical or electrical sections, a request in writing to be allowed to make the substitution shall be made. This request shall be accompanied by complete plans and specifications of the substitution offered. If so requested by the Engineer, also submit samples of both the specified material or appliance and the substitute.

2.3 MOTOR CONTROL:

- A. All motors will be fed from a motor starter. Motor starters shall be furnished by each respective trade for motor driven equipment provided by them. The Electrical Contractor shall install the starters and shall provide all power wiring to the starters, and from the starters to the motors they control. Where required, remote pushbuttons, plates and pilots will be furnished with the starter and will be installed by the Electrical Contractor, unless otherwise called for under the Temperature Control Section of these specifications. All starters for motors which are to be interlocked with another motor shall have suitable auxiliary contacts.
- B. All small motors without built-in thermal protection shall be furnished with thermal switches. These switches and pilots shall be furnished by the Electrical Contractor.

2.4 ELECTRIC MOTORS:

- A. All motors 1/2 h.p. and above shall be integral horsepower polyphase induction motors conforming to NEMA standards MG-1-1967 and shall be T-frame design in sizes 143 T through 445 T. Each shall be NEMA design B with minimum torque values per MG 1-12.37 and 12.38.
- B. Duty shall be continuous, ambient temperature 40 degrees maximum, allowable temperature rise for open drip-proof -90 degrees, TEFC, 80 degrees C with Class B insulation rating all per MG 1-12.42.
- C. Horsepower, speed and frame sized per MG 1-10, 32, 13.02 and 13.06a.
- D. Enclosures - open drip-proof and TEFC per MG 1-1.25, 1.26 and 1.27.
- E. All dimensions per MG 1-11.31a, 11.32a and 11.34a. All motors shall have stainless steel nameplates with NEMA voltage standards shown.
- F. Locked rotor KVA per horsepower shall be designated by proper NEMA code letter per MG 1.10.37.
- G. All motors shall be premium efficiency type with a full load efficiency range of 80 percent to 95 percent. High efficiency motor rating shall meet Northeast Utilities Energy Action Program in accordance with the following schedule:

MINIMUM NOMINAL MOTOR EFFICIENCIES

**GLASTONBURY FIRE HOUSE  
BOILER REPLACEMENT  
GLASTONBURY, CONNECTICUT**

HP	OPEN DRIP PROOF			HP	TOTALLY ENCLOSED		
	MINIMUM EFFICIENCY				MINIMUM EFFICIENCY		
	1200	1800	3600		1200	1800	3600
1	82.5%	85.5%	80.0%	1	82.5%	85.5%	78.5%
1.5	86.5%	86.5%	85.5%	1.5	87.5%	86.5%	85.5%
2	87.5%	86.5%	86.5%	2	88.5%	86.5%	86.5%
3	89.5%	89.5%	86.5%	3	89.5%	89.5%	88.5%
5	89.5%	89.5%	89.5%	5	89.5%	89.5%	89.5%
7.5	91.7%	91.0%	89.5%	7.5	91.7%	91.7%	91.0%
10	91.7%	91.7%	90.2%	10	91.7%	91.7%	91.7%
15	92.4%	93.0%	91.0%	15	92.4%	92.4%	91.7%
20	92.4%	93.0%	92.4%	20	92.4%	93.0%	92.4%
25	93.0%	93.6%	93.0%	25	93.0%	93.6%	93.0%
30	93.6%	94.1%	93.0%	30	93.6%	93.6%	93.0%
40	94.1%	94.1%	93.6%	40	94.1%	94.1%	93.6%
50	94.1%	94.5%	93.6%	50	94.1%	94.5%	94.1%
60	95.0%	95.0%	94.1%	60	94.5%	95.0%	94.1%
75	95.0%	95.0%	94.5%	75	95.0%	95.4%	94.5%
100	95.0%	95.4%	94.5%	100	95.4%	95.4%	95.0%

- H. Service Factors - open-drip-proof, 1 h.p. through 200-1.15 TEFC all horsepower - 1.0.
- I. Noise level within NEMA standard MG 1-12.49.
- J. In addition to the above, all motors 1 through 20 h.p. shall be TEFC with drain holes for both horizontal and vertical positions. Each shall be equipped with deep groove double shielded ball bearings prelubricated with provisions for regreasing.
- K. Motors smaller than 1/2 h.p. shall be capacitor-start or split-phase type designed for 120 volts, single phase, 60 cycles alternating current.



2.5 ELECTRICAL MOTOR STARTERS:

- A. Motor starters shall be furnished by each respective trade for motor driven equipment provided by them. The Electrical Contractor shall install the starters and shall provide all power wiring to the starters, and from the starters to the motors they control.
- B. Motor starters shall conform to requirements of NEC, NEMA, UL, CSA, and ANSI and shall be suitable for the required horsepower, duty, voltage, phase, frequency, service, and location. All starters shall be furnished in NEMA enclosures suitable for the environment in which they are to be located.
- C. All starters shall be of the same manufacture and shall be furnished in Cutler-Hammer, Square D, General Electric, or Allen Bradley.
- D. Thermal Overloads:
  - 1. All motors 1/8 horsepower or larger shall be provided with thermal-overload protection. Thermal overloads shall be melting alloy ambient temperature compensating type.
  - 2. Thermal overloads shall be sized in accordance with NEC requirements for the nameplate data of the motor(s) as actually delivered to the site.
- E. Starters for manual control of single phase motors up to one (1) horsepower furnished without integral thermal overloads shall be combination manual disconnect switch and starters with thermal overload protection for each ungrounded leg. Starters shall be inoperable if a thermal unit is removed. These starters shall be 2-pole and shall be provided with green neon pilot light and handle guard/lock-off.
- F. Starters for three phase motors shall be full voltage, circuit breaker combination magnetic starters. All circuit breaker combination magnetic starters shall include melting alloy type thermal overload protection, low voltage protection, and two (2) sets of auxiliary normally open and normally closed contacts. Thermal overload protection shall be provided in each ungrounded leg. Starters shall be inoperable if a thermal unit is removed.

All circuit breaker combination magnetic starters shall be equipped with control power circuits. Provide starters with control power transformers of secondary voltage required for the control power circuitry. Provide control power transformers with primary and secondary fusing.

The disconnect handle on circuit breaker combination magnetic starters shall always be in control of the disconnect device with the door opened or closed. The disconnect handle shall be clearly marked as to whether the disconnect device is "on" or "off", and shall include a two-color handle grip, the black side visible in the "off" position, and the red side visible in the "on" position.

- 1. All circuit breaker combination magnetic starters for manual control of three phase motors shall have start-stop push buttons in the cover and shall be provided with red and green pilot lights.
- 2. All circuit breaker combination magnetic starters for automatic or interlocking control of three phase motors shall have hand-off-automatic selector switches in the cover and shall be provided with red and green pilot lights.

**GLASTONBURY FIRE HOUSE  
BOILER REPLACEMENT  
GLASTONBURY, CONNECTICUT**

- G. Starters shall be furnished as part of respective equipment furnished under each Division.

**PART 3 - EXECUTION**

**3.1 CONNECTING TO EXISTING UTILITIES:**

- A. Connections to existing utilities that will interrupt the service to the present buildings shall be made at a time agreed upon by the Town,.
- B. If it is necessary to make connections to existing utilities outside the regular working hours, this shall be noted on the written work order and the respective Contractor will be paid for the additional cost of labor over and above what it would cost at regular day time rates.

**3.2 FREIGHT, CARTING AND RIGGING:**

- A. Contractor shall pay all freight and carting charges necessary to deliver all equipment furnished under his Contract to the site and furnish all necessary rigging to properly rig and set the apparatus on the foundations, frames, etc.
- B. All scaffolding, blocks and tackle, ropes and chains and other equipment necessary to rig and set the apparatus shall be furnished by the Contractor.
- C. The Contractor shall set, level and align all equipment before starting operations.

**3.3 SEISMIC RESTRAINTS:**

- A. It is the intent of this seismic restraint portion of the specification to provide restraint of all non-structural building system components provided in Sections 15 and 16 in Seismic Zone II. Restraint systems and devices are intended to withstand, without failure, the "G" forces detailed in the chart below:

Design Level of Acceleration At Equipment Center of Gravity Seismic Zone 2)  
(Av - >0.1 to 0.19)

Elevation (feet rel. to grade level)	Rigid* Mnt'd Equip	Non-Struct. Architect Component	Flexible* Mnt'd Equip	Pipe, Duct, Cable trays, Conduit, Etc.	Life Safe. Equip
Below Grade up to 20 feet above grade	0.125 "g"	0.250 "g"	0.500 "g"	0.350 "g"	1.000 "g"
21 ft. - 300 ft.	0.500 "g"	0.550 "g"	0.750 "g"	0.650 "g"	1.000 "g"
301 ft. - 600 ft.	0.750 "g"	0.900 "g"	1.000 "g"	1.000 "g"	1.000 "g"

\* Rigid mounted equipment is any equipment mounted directly to structure. Flexible mounted equipment is any equipment mounted on resilient supports, ceiling suspended, roof supported or mounted on an independent frame with any primary natural frequency below 16 Hz.

- B. Seismic restraints shall be as required by 2003 IBC, Chapter 16 and State of Connecticut 2005 Supplement.

**GLASTONBURY FIRE HOUSE  
BOILER REPLACEMENT  
GLASTONBURY, CONNECTICUT**

C. Seismic Certificant and Analysis

1. Seismic restraint calculations must be provided for all connections of equipment to the structure.
2. Calculations to support seismic restraint designs must be stamped by a registered professional engineer licensed in the State of Connecticut.
3. Analysis must indicate dead loads, derived loads, and materials used for connections to equipment and structure. Analysis must detail anchoring methods, bolt diameters, embedment, and weld length.
4. A seismic design errors and omissions insurance certificate must accompany submittals.

D. Submit drawings showing locations of all seismic restraints for equipment, piping, and conduit provided under Sections 15 and 16:

1. The term EQUIPMENT includes ALL non-structural components. These specifications are applicable within the facility and 5 feet outside of the foundation wall. Equipment buried underground is excluded but entry of services through the foundation wall is included. Equipment referred to below is a partial list; (equipment not listed is still included in this specification).

Air Separators	Water Heater
Light Fixtures	Bus Ducts
Piping	Boiler
Pumps (All types)	Cable Trays
Switching Gear	Tanks (All types)
Conduit	All Electrical Panels

E. Submittals shall include a listing of all isolated and non-isolated equipment to be restrained.

F. Seismic restraints shall not be required for the following installations:

1. Piping in mechanical rooms less than 1 1/4-inch inside diameter.
2. All other piping less than 2 1/2-inch inside diameter.
3. All electrical conduit less than 2 1/2-inch inside diameter.
4. All rectangular air-handling ducts less than 6 square feet in cross-sectional area.
5. All round air-handling ducts less than 28 inches in diameter.
6. All piping suspended by individual hangers 12 inches or less in length from the top of the pipe to the bottom of the support for the hanger.
7. All ducts suspended by hangers 12 inches or less in length from the top of the duct to the bottom of the support for the hanger.

G. Life safety systems defined:

1. All systems involved with fire protection including sprinkler piping, service water supply piping, fire dampers and smoke exhaust systems.
2. All systems involved with and/or connected to emergency power supply including all generators, transfer switches, transformers and all flowpaths to fire protection and/or emergency lighting systems.



**GLASTONBURY FIRE HOUSE  
BOILER REPLACEMENT  
GLASTONBURY, CONNECTICUT**

3. Fresh air relief systems on emergency control sequence including air handlers, conduit, duct, dampers, etc.

**3.4 COOPERATION WITH OTHER TRADES:**

- A. No piping, conduit, valves, boxes, etc., shall be installed until the entire run has been checked for clearance and the work has been coordinated between all the trades. Each tradesman shall be responsible for taking his own field measurements and maintaining proper clearance from the Town's equipment and the work of other trades, and for coordinating his work with that of other Contractors and Town. Furnish all necessary information, dimensions, templates, etc. in order that a perfectly coordinated job will result.
- B. Contractor shall carry out his work in conjunction with other trades and shall give full cooperation to other trades. Contractor shall furnish all information necessary to permit work of all trades to be installed in a satisfactory manner.
- C. Where space is so limited that Contractor's work shall be installed in close proximity to the work of other trades or where it is evident that Contractor's work will interfere with other trades, he shall assist in working out space conditions to make satisfactory adjustments. If required or directed by Engineer, the Contractor shall prepare composite working drawings and sections of not less than 3/4" -1'-0" scale clearly showing how his work is to be installed in conjunction with other trades; he shall make corrections necessary to satisfactorily complete installation at no additional cost to Town.
- D. All supports for hanging material to be connected to steel structure shall be installed prior to installation of fire proofing material. Any damage to fireproofing caused by late installation of hanging material shall be repaired by the Fire-proofing Contractor at the expense of the Contractor responsible.
- E. The Heating Contractors shall give to the Electrical Contractor all information on switches, controls, pilots, etc. furnished under the Heating Contracts, together with makes and catalog numbers where required to permit the Electrical Contractor to leave the proper boxes to receive same. This information shall be given well in advance so that the Electrical Contractor may install his work as construction progresses. In the event that this information is not given in time to permit the Electrical Contractor to leave proper boxes, etc. as construction progresses, it shall be the responsibility of the Contractor to pay all costs of cutting and patching.

**3.6 INFORMATION FOR ELECTRICAL CONTRACTOR:**

- A. Deliver to the Electrical Contractor all information on motors and controls furnished under the Mechanical Contract, together with makes and catalog numbers, to permit the Electrical Contractor to leave the proper boxes and wiring.

**3.7 SLEEVES, INSERTS AND ANCHOR BOLTS:**

**GLASTONBURY FIRE HOUSE  
BOILER REPLACEMENT  
GLASTONBURY, CONNECTICUT**

- A. All pipes and conduits passing through floors, walls or partitions shall be provided with sleeves sized to give a minimum of 1/2" clearance between sleeve and the outside diameter of the pipe, conduit or insulation, enclosing the pipe or conduit.
- B. Sleeves through concrete floors or interior masonry walls shall be Schedule 40 steel pipe, set flush with finished wall or ceiling surfaces, but extending 2 inches above finished floors or shall be in accordance with details on drawings. In all mechanical equipment rooms sleeves shall extend 6 inches above finished floor.
- C. Inserts shall be individual or strip type of steel or malleable iron construction for removable nuts and threaded rods up to 3/4" diameter, permitting lateral adjustment.

**3.8 FIRE STOPPING:**

- A. General
  - 1. Firestopping: Material or combination of materials used to retain integrity of fire-rated construction by maintaining an effective barrier against the spread of flame, smoke, and hot gases through penetrations in fire rated wall and floor assemblies.
- B. General Description of The Work
  - 1. Only tested firestop systems shall be used in specific locations as follows:  
Penetrations for the passage of duct, cable, cable tray, conduit, piping, electrical busways and raceways through fire-rated vertical barriers (walls and partitions), horizontal barriers (floor/ceiling assemblies), and vertical service shaft walls and partitions.
- C. References
  - 1. Test Requirements: ASTM E-814, "Standard Method of Fire Tests of Through Penetration Fire Stops" (July 1997).
  - 2. Underwriters Laboratories (UL) of Northbrook, IL runs ASTM E-814 under their designation of UL 1479 and publishes the results in their "FIRE RESISTANCE DIRECTORY" that is updated annually.
  - 3. International Firestop Council Guidelines for Evaluating Firestop Systems Engineering Judgments
  - 4. Test Requirements: ASTM E 84-96, "Surface burning characteristics".
  - 5. All major building codes: ICBO, SBCCI, BOCA, and IBC.
  - 6. Test Requirements: ASTM E-119, "Fire Test of Building Construction and Materials" (UL 263)
- D. Quality Assurance
  - 1. Firestop System installation must meet requirements of ASTM E-119, ASTM E-814, ASTM E-84-96, UL 236, UL 1479 or UL 2079 tested assemblies that provide a fire rating equal to that of construction being penetrated.
  - 2. Firestop Systems do not reestablish the structural integrity of load bearing partitions/assemblies, or support live loads and traffic. Installer shall consult the structural engineer prior to penetrating any load bearing assembly.

**GLASTONBURY FIRE HOUSE  
BOILER REPLACEMENT  
GLASTONBURY, CONNECTICUT**

**E. Submittals**

1. Submit Product Data: Manufacturer's specifications and technical data for each material including the composition and limitations, documentation of UL firestop systems to be used and manufacturer's installation instructions to comply with Section 1300.
2. Submit material safety data sheets provided with product delivered to job-site.

**F. Installer Qualifications**

1. Engage an experienced Installer who is certified, licensed, or otherwise qualified by the firestopping manufacturer as having been provided the necessary training to install manufacture's products per specified requirements.

**G. Products, General**

1. Provide firestopping composed of components that are compatible with each other, the substrates forming openings, and the items, if any, penetrating the firestopping under conditions of service and application, as demonstrated by the firestopping manufacturer based on testing and field experience.
2. Provide components for each firestopping system that are needed to install fill material. Use only components specified by the firestopping manufacturer and approved by the qualified testing agency for the designated fire-resistance-rated systems.
3. Firestopping Materials are either "cast-in-place" (integral with concrete placement) or "post installed." Provide cast-in-place firestop devices prior to concrete placement.

**H. Acceptable Manufacturers**

1. Subject to compliance with through penetration firestop systems (XHEZ) and joint systems (XHBN) listed in Volume II of the UL Fire Resistance Directory, provide products of the following manufacturers as identified below:
  - a. Hilti, Inc., Tulsa, Oklahoma 800-879-8000
  - b. Other manufacturers listed in the U.L. Fire Resistance Directory – Volume 2

**I. Materials**

1. Use only firestop products that have been UL 1479, ASTM E-814, or UL 2079 tested for specific fire-rated construction conditions conforming to construction assembly type, penetrating item type, annular space requirements, and fire-rating involved for each separate instance.
2. Provide a firestop system with a "F" Rating as determined by UL 1479 or ASTM E814 which is equal to the time rating of construction being penetrated.
3. Provide a firestop system with an Assembly Rating as determined by UL 2079 which is equal to the time rating of construction being penetrated.

**J. Preparation**

**GLASTONBURY FIRE HOUSE  
BOILER REPLACEMENT  
GLASTONBURY, CONNECTICUT**

1. Verification of Conditions: Examine areas and conditions under which work is to be performed and identify conditions detrimental to proper or timely completion.
  - a. Verify penetrations are properly sized and in suitable condition for application of materials.
  - b. Surfaces to which firestop materials will be applied shall be free of dirt, grease, oil, rust, laitance, release agents, water repellents, and any other substances that may effect proper adhesion.
  - c. Provide masking and temporary covering to prevent soiling of adjacent surfaces by firestopping materials.
  - d. Comply with manufacturer's recommendations for temperature and humidity conditions before, during and after installation of firestopping.
  - e. Do not proceed until unsatisfactory conditions have been corrected.

**K Coordination**

1. Coordinate location and proper selection of cast-in-place Firestop Devices with trade responsible for the work. Ensure device is installed before placement of concrete.
2. Responsible trade to provide adequate spacing of field run pipes to allow for installation of cast-in-place firestop devices without interferences.

**L. Installation**

1. Regulatory Requirements: Install firestop materials in accordance with UL Fire Resistance Directory.
2. Manufacturer's Instructions: Comply with manufacturer's instructions for installation of through-penetration and construction joint materials.
  - a. Seal all holes or voids made by penetrations to ensure an air and water resistant seal.
  - b. Consult with project manager, and damper manufacturer prior to installation of UL firestop systems that might hamper the performance of fire dampers as it pertains to duct work.
  - c. Protect materials from damage on surfaces subjected to traffic.

**M. Field Quality Control**

1. Examine sealed penetration areas to ensure proper installation before concealing or enclosing areas.
2. Keep areas of work accessible until inspection by applicable code authorities.
3. Perform under this section patching and repairing of firestopping caused by cutting or penetrating of existing firestop systems already installed by other trades.

**N. Adjusting and Cleaning**

1. Remove equipment, materials and debris, leaving area in undamaged, clean condition.
2. Clean all surfaces adjacent to sealed holes and joints to be free of excess firestop materials and soiling as work progresses.



**3.9 ACCESSIBILITY:**

- A. Locate all equipment which must be serviced, operated or maintained in fully accessible positions. Equipment shall include but not be limited to motors, controllers, switchgear, drain points, etc.
- B. In the event that any equipment is not installed to permit convenient servicing, disassemble, removal of parts, etc. the Contractor shall, at his own expense, make all corrections necessary to accomplish this.

**3.10 LUBRICATION:**

- A. All equipment having moving parts and requiring lubrication which is installed under this Contract, shall be properly lubricated according to manufacturer's recommendations prior to testing and operation. Any such equipment discovered to have been operated before lubrication is subject to rejection and replacement at no cost to the Town. Units furnished with sealed bearings are accepted.

**3.11 TAGS, CHARTS AND NAMEPLATES:**

- A. Each valve, control, switch, electrical panel, motor and any piece of apparatus installed under these sections shall be properly identified.
- B. Each sectional shutoff valve shall have a brass tag with identifying number. Tag shall be secured to valve stem with sufficient length of copper coated jack chain to allow tag to be easily read.
- C. All other equipment, including panels and switches, shall be provided with a suitable laminated plastic nameplate fastened with screws or rivets. Small equipment labels may use a pressure sensitive tape.
- D. All nameplates and labels shall identify components by proper nomenclature and numbered according to equipment schedule or as designated.
- E. Charts shall be furnished in duplicate and shall include the valve identification number, location and purpose. One chart shall be mounted in frame with a clear glass front and secured to wall in location directed.  
Second chart shall be for use throughout building and shall be provided with transparent plastic closure for top and attached 8" bead chain for hanging. Holes to be reinforced with brass grommets. Tags and closures as manufactured by Seton Name Plate Corp., New Haven, Conn., or approved equal.

**3.12 INSTRUCTIONS:**

- A. Prepare written instructions frames for the proper maintenance and operation of any special equipment furnished and installed under this Contract.

**GLASTONBURY FIRE HOUSE  
BOILER REPLACEMENT  
GLASTONBURY, CONNECTICUT**

- B. Personally instruct the Town's Custodian or official representative in addition to furnishing all manuals, diagrams, etc. in the proper operation and maintenance of all equipment and piping installed under this Contract.
- C. Prepare a portfolio with all tags, operating manuals, parts lists, guarantees, etc. that are packed with all equipment furnished under this Contract and submit same to the Architect.

**3.13 PIPING CODE MARKERS:**

- A. All service piping which is accessible for maintenance operations shall be identified with vinyl plastic color bands and legends at each branch and riser take-off, at each passage through wall, floor and ceiling, adjacent to each valve and on all pipe runs marked each 20'-0". Pipe markers to conform to A.S.A. Bulletin A-13. Where pipes are too small for legends, brass identification tags 1-1/2" in diameter with depressed 1/2" high black filled letters shall be fastened with chain. Pipe markers and tags as manufactured by the Seton Name Plate Corp., New Haven, Conn., or equal approved.

**3.14 CLEANING PIPING, CONDUITS AND EQUIPMENT:**

- A. Thoroughly clean all piping and equipment of all foreign substances inside and out before being placed in operation.
- B. If any part of a system should be stopped by any foreign matter after being placed in operation, the system shall be disconnected, cleaned and reconnected wherever necessary to locate and remove obstructions.  
Any work damaged in the course of removing obstructions shall be repaired or replaced when the system is reconnected at no additional cost to the Town.
- C. During the course of construction, all pipe and electrical conduits shall be capped in an approved manner to insure adequate protection against the entrance of foreign matter.

**3.15 CLEANING UP:**

- A. After completion of the work, remove all waste, rubbish and other materials left as a result of operations and leave the premises in clean condition.
- B. All fixtures, equipment, etc. installed under the Mechanical and Electrical Sections shall be free of dirt, grease and other foreign material and left in perfectly clean condition and ready to use.

**3.16 GUARANTEE:**

- A. All parts of the work and all equipment shall be guaranteed for a period of 18 months from the date of acceptance of the job by the Town.
- B. If during that period of general guarantee, any part of the work installed fails, becomes unsatisfactory or does not function properly due to any fault in material or workmanship, whether or not manufactured or job built, each section shall upon notice from the Town, promptly proceed to repair or replace such faulty material or workmanship without expense to the Town, including cutting, patching and painting or any other work involved and

**GLASTONBURY FIRE HOUSE  
BOILER REPLACEMENT  
GLASTONBURY, CONNECTICUT**

including repair or restoration of any damaged sections of the premises resulting from such faults.

- C. In the event, that a repetition of any one defect occurs, indicating the probability of further failure, and which can be traced to faulty design, material or workmanship, then repairs or replacement shall not continue to be made but, the fault shall be remedied by a complete replacement of the entire defective unit.
- D. In addition to the general guarantee, obtain and transmit to the Town any guarantees or warranties from manufacturers of specialties but only as a supplement to the general guarantee which will not be invalidated by same.

3.17 TOWN'S INSTRUCTIONS AND SYSTEM OPERATION:

- A. At the time of the job's acceptance by the Town, Contractor shall furnish maintenance and operating instructions for all equipment including parts list. These instructions shall be written in layman's language and shall be inserted in vinyl covered three-ring loose leaf binder. This information in binder shall be first sent to the approved by the Architect/Engineer before turning over to the Town.
- B. Upon completion of all work and of all tests, each Division shall furnish the necessary skilled labor and helpers for operating the system and equipment for a period of one (1) day of eight (8) hours, or as otherwise specified. During this period, instruct the Town or his representative fully in operation, adjustment and maintenance of all equipment furnished. Give at least forty-eight (48) hours notice to the Town in advance of this period.

3.18 TOWN'S ACCEPTANCE TEST:

- A. After the various systems are complete as determined by preliminary operating tests, the Contractor shall arrange for the Town's final acceptance tests.
- B. The Contractor shall have present at each acceptance test, representatives of the several Contractors whose work is directly or indirectly involved, with instruments as necessary in accordance with the design and to include the following.
  - 1. All equipment installed and operating in accordance with manufacturer's instructions and performance guarantee.
  - 2. All systems operating in accordance with specifications.
  - 3. All distribution systems properly adjusted for distribution to equipment as specified.
  - 4. The various systems properly flushed, cleaned, and free of entrapped air and dirt.
  - 5. All motors installed with proper thermal overload protection and not operating under overload conditions as determined by ammeter readings.
  - 6. All valve charts, etc. as specified in various parts of the specifications installed or ready for delivery to the Town.
- C. The date of the Town's acceptance of the equipment shall be the start of the one year guarantee period.

3.19 TEST:

**GLASTONBURY FIRE HOUSE  
BOILER REPLACEMENT  
GLASTONBURY, CONNECTICUT**

- A. Conducting Tests: Conduct all tests called for under the various sections or as required and repair or replace any defects. Perform all tests in the presence of and to the satisfaction of the Engineer and such other parties as may have legal jurisdiction.
- B. Defective Work: The Town shall have the privilege of stopping any of the work not being properly installed. All such defective work shall be repaired or replaced and the tests shall be repeated.
- C. Repair Damaged Work: Repair all damages resulting from tests and replace damaged materials.

END OF SECTION 15010



SECTION 15180

INSULATION

PART 1 - GENERAL

1.1 RELATED DOCUMENTS:

- A. The General Provisions of the Contract, including General and Supplementary Conditions and Division 1, General requirements, apply to the work specified in this Section.
- B. The General Requirements in Section 15010 shall also govern the work under this Section.
- C. Scope of Work: This Section contains details for the insulation of pipe, ductwork and equipment installed under Division 15.

1.2 SUBMITTALS:

- A. In accordance with Section 15010, the following items shall be submitted for approval.
  - Piping insulation
  - Fitting insulation
  - Equipment insulation

1.3 MECHANICAL SYSTEMS INSULATION:

- A. Furnish and install all thermal and protective insulation as specified herein for piping, and equipment as shown on the drawings.
- B. The following mechanical items shall be insulated:
  - Piping - hot and cold, steam and condensate
  - Fittings - Valve bodies, Victaulic couplings, elbows, tees, etc.
  - Equipment insulation

1.4 SYSTEM PERFORMANCE

- A. Insulation materials furnished and installed hereunder should meet the minimum thickness requirements of ASHRAE 90.1 (2001), "Energy Efficient Design of New Buildings," of the American Society of Heating, Refrigeration, and Air Conditioning Engineers. However, if other factors such as condensation control or personnel protection are to be considered, the selection of the thickness of insulation should satisfy the controlling factor.
- B. Insulation materials furnished and installed hereunder shall comply with NFPA 255 and shall have a maximum flame spread index of 25 and a maximum smoke developed index of 50 when tested in accordance with the following testing standard:
  - Underwriters' Laboratories, Inc. UL 723
  - Adhesives used for applying the sealed jackets shall also conform to these same ratings. The use of wheat paste or any other material not meeting these requirements will not be allowed.

1.5 QUALITY ASSURANCE

**GLASTONBURY FIRE HOUSE  
BOILER REPLACEMENT  
GLASTONBURY, CONNECTICUT**

- A. Insulation materials and accessories furnished and installed hereunder shall, where required, be accompanied by manufacturers' current submittal or data sheets showing compliance with applicable specifications.
- B. Insulation materials and accessories shall be installed in a workmanlike manner by skilled and experienced workers who are regularly engaged in commercial insulation work.
- C. All covering and insulating materials shall be manufactured by Owens-Corning, Knauf, Johns Manville or Armstrong.

1.6 SEAMS:

- A. On exposed insulation, all longitudinal seams shall be kept at the top and back of the pipe and circumferential joints shall be kept to a minimum. Raw end of insulation shall be concealed by neatly folding the ends of the jackets. Fittings, valve bodies and flanges shall be furnished with the same jacket materials used on adjoining insulation.

1.7 PRIOR TESTING:

- A. Covering shall not be applied until all parts of the work have been tested by the Contractor and reviewed by the Engineer.

1.8 VAPOR BARRIER:

- A. Vapor barrier shall be applied in accordance with the manufacturer's instructions to maintain the integrity of the vapor barrier on cold systems.
- B. An approved vapor retarder mastic compatible with PVC must be applied between pipe insulation and fitting cover, and on fitting cover and throat overlap seam.
- C. For fittings where operating temperature is below 45 deg. For where pipe insulation thickness is greater than 1 1/2", two or more layers of Hi-Lo temp insulation inserts shall be installed beneath fitting cover.

1.9 METAL SHIELDS:

- A. Metal shields, 16 gauge galvanized, shall be applied between hangers or supports and the pipe insulation. Shields shall be roll formed to fit the insulation and shall extend up to the center line of the pipe and the length specified for the insert. Insulation shall be rigid type for length of shield to prevent crushing.

1.10 DELIVERY AND STORAGE OF MATERIALS

- A. All of the insulation materials and accessories covered by this specification shall be delivered to the job site and stored in a safe, dry place with appropriate labels and/or other product identification.
- B. The contractor shall use whatever means are necessary to protect the insulation materials and accessories (wick material, sealing tape, etc) before, during, and after installation. No

**GLASTONBURY FIRE HOUSE  
BOILER REPLACEMENT  
GLASTONBURY, CONNECTICUT**

insulation material shall be installed that has become damaged in any way. The contractor shall also use all means necessary to protect work and materials installed by other trades.

**PART 2 - PRODUCTS**

**2.1 PIPING:**

- A. Insulate all new and existing domestic hot water, recirculating hot water lines, steam and condensate lines in the Boiler Room and adjacent equipment room, with Owens-Corning Fiberglass ASJ with S.S.L. II, pipe insulation with double self-sealing lap having a factory applied jacket. All horizontal and vertical insulated piping located below 8'-0" AFF level and not protected with enclosures shall be protected with Zeston 2000 P.V.C. 30 Mil jacketing.
- B. All piping shall be covered as follows: Apply insulation to clean dry pipe with side and end joints butted tightly. Seal lap of jacket and butt joint strips with Benjamin Foster 82-07 vapor barrier lap adhesive.  
Insulate fittings, flanges and valves of piping with mitered pipe insulation, or F/G premolded fittings made smooth with insulating cement and jacket with glass cloth saturated with Benjamin Foster 30-60 lagging adhesive. Vinyl or plastic fitting jackets will be allowed.
- C. Insulate domestic cold water, in the same as for hot piping above except vapor seal all joints, seams, elbows and fittings.
- D. Foam insulation:
  - 1. Piping and Fittings. MicroLok plain pipe insulation shall be wired or taped in place over clean, dry pipe with all joints butted firmly together. Vapor retarder shall be Micro-Lok AP-T plus.
  - 2. The insulation shall be finished with metal jacketing with a laminated moisture retarder. Metal jacketing shall be overlapped 2 to 3 inches (51 to 76 mm) and held in place with sheet metal screws or metal bands.
  - 3. Elbows and tees shall be finished with matching metal fitting covers. Other fittings in metal-jacketed systems shall be finished with conventional weather-resistant insulating materials with painted aluminum finish.

**GLASTONBURY FIRE HOUSE  
BOILER REPLACEMENT  
GLASTONBURY, CONNECTICUT**

- E. Provide minimum insulation thickness in accordance with the following table.  
Minimum Pipe Insulation

Piping System Types	Conductivity	Mean Rating temp	Fluid Temp. Range	Runout 2 in +	1 in. and less	1-1/4 to 2 in.	2-1/2 to 4 in.	5 and Larger
	BTUin/hsqftF	F	F	in.	in.	in.	in.	in.
<b>Heating Systems</b>								
Medium Pr./Temp	.29-.32	200	251-305	1.5	2.0	3.0	3.0	3.0
Low Pr./Temp	.27-.30	150	201-250	1.0	1.5	2.0	2.0	2.0
Low Temp	.25-.29	125	120-200	0.5	1.0	1.0	1.5	1.5
<b>Plumbing Systems</b>								
Hot Water	.22-.28	100	100-200	1.0	1.0	1.0	1.5	1.5
Cold Water Cond. Drains	.22-.28	100	40-60	0.5	1.0	1.5	1.5	1.5

Reinsulate piping where insulation has been disturbed under this contract (outside the mechanical room and adjacent equipment room) and feather to remaining insulation.

**2.2 FITTING COVERS:**

- A. Fitting covers may be used in lieu of insulating cement and jacket. Provide fitting covers in Zeston - 2000 P.V.C. (20 Mil thickness) by Manville.
- B. General - The matching insert (fiberglass) should either be wrapped completely around the fitting or snugly positioned inside the fitting for proper fit. The insert shall cover the full inner surface area of the fitting cover. The fitting cover is then to be applied over the fitting and insert, and the throat secured by either tack fastening, taping, or banding.
- C. Cold Pipe - Fitting systems below ambient temperature must have a continuous vapor barrier, either with pressure sensitive PVC Tape, or an approved adhesive system. When PVC Tape is used, a 2" downward lap is required. On cold lines in severe ambient temperatures, the fiberglass insert shall be the same thickness as the adjacent pipe insulation. All joints shall then be sealed with PVC Tape.
- D. Hot Pipe - For hot piping which requires pipe insulation over 1-1/2" wall, an extra inch of wall thickness in the pipe insulation shall be applied. If the surface temperature of insulation exceeds 155 degrees F. fitting covers should not be used. The throat seam shall be riveted or tacked on hot piping.



PART 3 – EXECUTION

3.1 SITE INSPECTION

- A. Before starting work under this section, carefully inspect the site and installed work of other trades and verify that such work is complete to the point where installation of materials and accessories under this section can begin.
- B. Verify that all materials and accessories can be installed in accordance with project drawings and specifications and material manufacturer's recommendations.
- C. Verify, by inspecting product labeling, submittal data, and/or certifications which may accompany the shipments, that all materials and accessories to be installed on the project comply with applicable specifications and standards and meet specified thermal and physical properties.

3.2 PREPARATION

- A. Ensure that insulation is clean, dry, and in good mechanical condition and that all factory-applied facings are intact and undamaged. Wet, dirty, or damaged insulation is not acceptable for installation.
- B. Ensure that pressure testing of piping and fittings has been completed prior to installing insulation.

3.3 INSTALLATION

- A. General
  - 1. Install all insulation materials and accessories in accordance with manufacturer's published instructions and recognized industry practices to ensure that it will serve its intended purpose.
  - 2. Install insulation on piping subsequent to painting, and acceptance tests.
  - 3. Install insulation materials with smooth and even surfaces. Insulate each continuous run of piping with full-length units of insulation, with single cut piece to complete run. Do not use cut pieces or scraps abutting each other. Butt insulation joints firmly to ensure complete, tight fit over all piping surfaces.
- B. Fittings
  - 1. Wrap valves, fittings, and similar items in each piping system with wicking material to ensure a continuous path (100% coverage) for the removal of condensation.
  - 2. Cover valves, fittings, and similar items in each piping system using one of the following:
    - a. Mitered sections of insulation equivalent in thickness and composition to that installed on straight pipe runs.

**GLASTONBURY FIRE HOUSE  
BOILER REPLACEMENT  
GLASTONBURY, CONNECTICUT**

- b. PVC Fitting Covers insulated with material equal in thickness and composition to adjoining insulation.
- 3. Seal all fitting joints with contractor supplied VaporWick Sealing Tape or approved vapor retarder mastic compound.
- C. Penetrations  
  
Extend piping insulation without interruption through walls, floors and similar piping penetrations.

**3.4 FIELD QUALITY ASSURANCE**

- A. Upon completion of all insulation work covered by this specification, visually inspect the work and verify that it has been correctly installed. This may be done while work is in progress, to assure compliance with requirements herein to cover and protect insulation materials during installation.

**3.5 PROTECTION**

- A. Replace damaged, removed or disturbed insulation with appropriate fiberglass insulation.
- B. The insulation contractor shall advise the general and/or the mechanical contractor as to requirements for protection of the insulation work during the remainder of the construction period, to avoid damage and deterioration of the finished insulation work.

**3.6 SAFETY PRECAUTIONS**

- A. Insulation contractor's employees shall be properly protected during installation of all insulation. Protection shall include proper attire when handling and applying insulation materials, and shall include (but not be limited to) disposable dust respirators, gloves, hard hats, and eye protection.
- B. The insulation contractor shall conduct all job site operations in compliance with applicable provisions of the Occupational Safety and Health Act, as well as with all state and/or local safety and health codes and regulations that may apply to the work.

END OF SECTION 15180

SECTION 15400

PLUMBING

PART 1 - GENERAL

1.1 RELATED DOCUMENTS:

- A. The General Provisions of the Contract, including General and Supplementary Conditions and General Requirements, apply to the work specified in this Section.
- B. The General Requirements in Section 15010 shall also govern the work under this section.

1.2 SCOPE OF WORK:

Gas systems

Domestic water systems

Plumbing equipment

- A. This contract includes all labor, material, equipment, tests and appliances required to furnish and install all plumbing as shown on drawings, implied and herein specified.
- B. The location of the building will be as shown on drawings. A visit to the site and examination of other Mechanical trades showing all details of construction is a requirement before submitting a proposal.
- C. The drawings are diagrammatic and indicate the general arrangement of piping and equipment, and do not show all minor details and fittings. Such items shall be included, as well as reasonable modifications, in the layout as directed to prevent conflict with other trades.
- D. Connect all equipment shown on drawings. Check all Mechanical drawings and coordinate all the work accordingly.
- E. Provide seismic restraints in accordance with Section 15010.

1.3 QUALITY ASSURANCE:

- A. Codes and Standards: All work shall comply with the Connecticut State Building Code, BOCA Plumbing Code, and NFPA Standards.
  - 1. 2005 Connecticut Supplement – Connecticut State Building Code
  - 2. 2003 International Building Code
  - 3. 2003 Life Safety Code
  - 4. 2003 International Plumbing Code
  - 5. 2003 International Mechanical Code
  - 6. Connecticut Gas Equipment and Piping Code
  - 7. 2003 International Energy Conservation Code
  - 8. 2002 State of Connecticut Public Health Code

**GLASTONBURY FIRE HOUSE  
BOILER REPLACEMENT  
GLASTONBURY, CONNECTICUT**

**1.4 SUBMITTALS:**

- A. **Shop Drawings:** Submit the following shop drawings:
- |                               |                            |
|-------------------------------|----------------------------|
| Plumbing fixtures & trim      | Cleanouts                  |
| Valves                        | Water heaters              |
| Pipes, fittings and couplings | Thermostatic mixing valves |
| Hangers and supports          |                            |

**1.5 PLUMBING SYSTEM DESCRIPTION:**

- A. Furnish and install all plumbing equipment shown on the drawings and herein specified. All equipment shall be complete and perfect and properly connected to water supply as required and left in complete operation.
- B. Before ordering equipment, Contractor shall submit brochures of all equipment and trim to the Engineer for review.
- C. Contractor shall include all permit fees and connection charges.

**1.6 WATER SERVICE:**

- A. Refer to drawings for service location. This Contractor shall make closing connection to existing water service. All work shall comply with the Local Water Company requirements.

**PART 2 - PRODUCTS**

**2.1 PIPE AND FITTINGS:**

- A. Listed below are references to the specification standards or recognized authorities to which pipe and fitting materials must conform.
- B. All reference shall be the current edition as recognized by the active codes. Each pipe length shall have the manufacturer's name cast, stamped or rolled on. Each fitting shall have the manufacturer's symbol and pressure rating cast, stamped or rolled on.
- C. Copper Tubing: shall be Type "K" or "L" seamless conforming to ASTM B 88. Cast bronze fittings to conform to ANSI B16.18 and wrought copper fittings to conform to ANSI B16.22.
- D. Solder: To be 95% tin, 5% antimony (lead free) conforming to ASTM B-32, grade 5A.
- E. Gas Piping:
1. The pipe shall be steel pipe, Schedule 40 complying with the ASTM A 53 Specification for Pipe, Steel, Black and hot-dipped, Zinc-Coated Welded and Seamless. The fittings shall be steel, malleable iron or ductile iron.
  2. Gas pipe shall be clear and free from cutting burrs and defects. Any defective pipe or fitting shall be replaced and shall not be repaired.



**GLASTONBURY FIRE HOUSE  
BOILER REPLACEMENT  
GLASTONBURY, CONNECTICUT**

3. Provide gas valves at all pressure regulators, at each piece of equipment, as shown on drawings and as required by codes. Gas solenoid valve for Kitchen is to be normally closed. Size as indicated on drawings.
4. No branch lines shall be taken from the bottom of horizontal runs.
5. Provide drips at any points in line where condensate may collect.
6. All gas piping shall be graded not less than 1/4" in 15'-0". All horizontal piping shall be graded to risers; provide capped drip at bottom of riser.
7. Provide dirt legs, gas valves, and unions at each equipment connection.

2.2 HANGERS:

- A. Securely hang and anchor pipe as shown and required with proper provision for expansion, contraction and elimination of undue stress and strain on piping.
- B. Provide a pipe hanger within two (2) feet of each elbow, tee, wye, valve, strainer and similar device.
- C. Secure and support runs at base and at sufficiently close intervals to hold pipe at alignment and to carry safely the weight of piping and contents without undue stress thereon.
- D. Except as indicated to the contrary, secure and support all horizontal piping as follows and required to prevent sagging, undue pipe movement and preserve proper alignment in each run.

<u>Piping</u>	<u>Size</u>	<u>Maximum Interval</u>
Steel	2" & smaller	Six (6) feet
Steel	2 1/2" & larger	Ten (10) feet
Copper Tubing	1 1/4" & smaller	Five (5) feet
Copper Tubing	1 1/2" & larger	Eight (8) feet

- E. Hangers up to and including 2" shall be the adjustable band type equal to Empire. Figure 310 for iron pipe and Fig. 310CT for copper tubing.
- F. Hangers for piping 2-1/2" and up shall be the clevis type, equal to Empire. Figure 11 for iron pipe and Figure 110CT for copper tubing.
- G. Hangers shall be suspended from one of the following devices:
  1. "C" clamps.
  2. Trapeze hanger assemblies consisting of back-to-back horizontal steel channels with end-type rod hangers.
  3. Expansion shield embedded into concrete or masonry.
- H. Provide seismic restraints in accordance with Section 15010.

**GLASTONBURY FIRE HOUSE  
BOILER REPLACEMENT  
GLASTONBURY, CONNECTICUT**

2.3 INSULATION:

- A. Refer to Section 15180.

2.4 VALVES:

- A. This Contractor shall furnish and install valves where shown on plans and also wherever necessary to make the system complete in its operation. All valves shall be as manufactured by Stockham, Jamesbury, Appollo, Centerline or Milwaukee as specified.

Hot water and cold water (domestic)

2" and smaller

Ball valves	Apollo - 71-100/200
Check valves	Stockham B-310-T

2-1/2" and larger

Butterfly valves	Stockham - LG712-BS3-B (Lug Style)
Check valves	Centerline - CLC - S.S. plates and spring nypalon seats

Furnish all valve materials suitable for service intended.

2.5 BACKFLOW PREVENTERS:

- A. 4" Reduced pressure Zone Assembly: Watts Model 957RPDA with non-rising stem gate valves, UL classified and FM approved. Provide with air gap fitting.
- B. 3/4", 1", & 2" Reduced pressure Zone Assemblies: Watts Model 909 with ball valves. Provide with air gap fitting.
- C. 1/2" Reduced pressure Zone Assembly: Watts Model 009 with ball valves valves, UL classified. Provide with air gap fitting.

PART 3 - EXECUTION

3.1 INSTALLATION:

- A. Check all plumbing and electrical drawings to make sure that this piping will not conflict with other work.
- B. All piping work shall be installed with provisions to allow for expansion and contraction of lines so as to prevent any undue strains on pipe and fittings, any trapping of lines or lifting or dislocating of any appliances.  
Rectify without cost to the Town any conditions of noisy circulation due to trapped or air bound lines, including the expense of cutting and repairing of the building structure incident to making such alterations.
- C. Install the work to conform to space conditions and the work of other trades. The drawings indicate generally the runs and the sizes of piping and although the size must not be decreased, nor the drawings deviated from except as unforeseen space conditions may

**GLASTONBURY FIRE HOUSE  
BOILER REPLACEMENT  
GLASTONBURY, CONNECTICUT**

require, the right is reserved to make minor changes in the arrangement of the work to meet the conditions arising during construction.

3.2 TESTS:

- A. Furnish all labor and materials for the performance of all tests as required by codes and by the authorized inspectors having jurisdiction.

3.3 HOT WATER PIPING:

- A. Extend the hot water piping as shown on plans which, in general, will follow the cold water.
- B. At low points, provide valved drain with hose connection with vacuum breaker.
- C. Pipe shall be copper Type "K" or "L" with wrought copper sweat fittings.

3.4 HOT WATER RECIRCULATING PIPING:

- A. Install the return circulation as shown on drawings.
- B. All recirculation lines shall be Type "K" or "L".

3.5 COLD WATER PIPING:

- A. Extend cold water piping as shown on plans.
- B. At low points, provide valved drain with hose connection with vacuum breaker.
- C. Pipe shall be copper type "K" or "L".

3.6 FUEL GAS PIPING:

- A. Pressure Testing
  - 1. The customer piping shall be pressure tested in accordance with the National Fuel Gas Code (NFPA\_54), current edition. The test medium shall be nitrogen (N2), carbon dioxide (CO2) or air. The test pressure and duration shall conform to NFPA-54 Section 4.14 and must be approved by the local authority having jurisdiction and the Local Gas Distribution Company (LDC).
- B. Purging and Placing Gas Piping into Operation
  - 1. Upon notification and meter being turned on by Local Distribution Gas Company, the house line can be placed in operation. All purging shall be done in accordance with NFPA-54 Section 4.3.2.
    - a. The air can be safety displaced with natural gas provided that a moderately rapid and continuous flow of gas is introduced at the meter and air is vented

**GLASTONBURY FIRE HOUSE  
BOILER REPLACEMENT  
GLASTONBURY, CONNECTICUT**

to the outside of the building by means of connecting a rigid pipe or a semi-rigid metallic tubing with appropriate fittings.

- b. The purge piping must be located outside of the building at a safe distance away from fresh air intakes and away from any source of ignition. The end of the purge riser must be equipped with a flash back arrestor. The purge riser must be manned at all times. A fire extinguisher must be placed nearby while purging is in operation. A combustion gas indicator (CGI) can be used to assure the house line is purged properly to 100% gas.
- c. In the event of multi-floor house lines, the longest house line (furthest from the meter) must be purged first, followed by the next longest, until all sections of house lines have been purged to 100% gas.

C. Odorant Level

- 1. All house lines must be continuously purged until such time that the Odorant level is sufficiently detachable by smell and confirmed with an ordinary level instrument such as Bacharach Model 5110-200, or equivalent.  
The instrument shall have a range of to 1.2% gas in air. The line must be purged until a readily detachable Odorant reading of 0.25% or less gas in air is maintained.
  - a. As soon as the acceptable level reading is maintained at all purging locations, turnoff the ends of house lines, disconnect the purging tubing, permanently plug all ends and leak test all plugs. Gas utilization equipment can now be purged and placed into operation.
  - b. Odorant level readings shall be re-taken periodically to ensure proper level of Odorant is maintained. Odorant level may decay especially in low flow house lines. If this occurs purging procedure must be repeated as needed.

3.7 PIPING JOINTS:

- A. Soldered Joints in Copper Tube: Cut the ends of tubes square, remove burrs, clean tube ends and fitting sockets with emery cloth, and remove all particles before applying flux and making the joint. Insert tubes to full socket depth. Use the following solders at the given conditions.
- B. All solder joints shall be made up with 95/5 solder.
- C. Plumbing Contractor shall be held responsible for any damages caused by water from poorly made joint.

3.8 REAMING OF PIPES:

- A. All pipes to be carefully reamed after cutting and threading.
- B. All steel pipe lines shall be reamed carefully before they are threaded. They shall be reamed smooth on the inside to give the full area of pipe in all cases.

**GLASTONBURY FIRE HOUSE  
BOILER REPLACEMENT  
GLASTONBURY, CONNECTICUT**

- C. All copper tubing shall be carefully cut square and true, carefully reamed and thoroughly cleaned. The inside of fittings shall be carefully cleaned. All tubing shall be inserted fully to the shoulder of fittings.

3.9 TESTING:

- A. All piping testing to be performed in accordance with all applicable Codes including, but not limited to IFC and CT Health Code.
- B. All involved parties are to be notified at least two weeks in advance of a scheduled test.

3.10 DISINFECTION:

- A. Disinfect new water piping in accordance with AWWA C601.
  - 1. The pipe system shall be flushed with clean, potable water until dirty water does not appear at the points of outlet.
  - 2. The system or part thereof shall be filled with a water/chlorine solution containing at least 50 parts per million (50mg/L) of chlorine, and the system or part thereof shall be valved off and allowed to stand for 24 hours; or the system or part thereof shall be filled with water/chlorine solution containing at least 200 parts per million (200mg/L) of chlorine and allowed to stand for 3 hours.
  - 3. Following the required standing time, the system shall be flushed with clean potable water until the chlorine is purged from the system.
  - 4. The procedure shall be repeated where shown by a bacteriological examination that contamination remains present in the system.

END OF SECTION 15400



SECTION 15700

HEATING EQUIPMENT

PART 1 - GENERAL

1.1 RELATED DOCUMENTS:

- A. The General Provisions of the Contract, including General and Supplementary Conditions and General Requirements, apply to the work specified in this Section.
- B. The General Requirements in Section 15010 shall also govern the work under this Section.
- C. Examine all drawings and data and coordinate the work of this Section with all related and adjoining work.

1.2 SCOPE OF WORK:

- A. This Contract includes all labor, material, equipment, tests and appliances required to furnish and install all HVAC as shown on drawings, implied and herein specified.
- B. The present location of the building will be as shown on drawings. Visit the site and examine the Mechanical trades showing all details of construction before submitting proposal.
- C. Connect new boilers and pumps to existing and leave ready to operate. Check all Mechanical and Electrical drawings and coordinate all work accordingly.
- D. Refer to Section 15010 for Seismic Restraints.
- E. Drawings are diagrammatic and indicate the general arrangement of piping and do not show all minor details and fittings. Such items shall be included, as well as reasonable modification, in the layout as directed to prevent conflict with other trades.

1.3 SUBMITTALS:

- A. In accordance with Section 15010, the following items shall be submitted for review.

Pipe and fittings  
Hydronic Equipment and Specialties

1.4 MOTOR CONTROL:

- A. Each electric motor of 3 phase characteristics shall be furnished with an automatic starter as specified in Section 15010, Motor Control.

PART 2 -PRODUCTS

**GLASTONBURY FIRE HOUSE  
BOILER REPLACEMENT  
GLASTONBURY, CONNECTICUT**

2.1 PIPE AND FITTINGS:

- A. Copper Tubing:
1. Type "L", ASTM Specifications B88, shall be used for water lines.
  2. Fittings shall be wrought copper or cast brass solder- joint pressure rated type.
  3. Type "K" shall be used for underground piping with flared fittings.
- B. Steel Piping:
1. Pipe shall be Standard Wall (Sch. 40) black carbon steel, ASTM A-120, Grade B, with threaded ends for sizes 1/2" through 2", for hot water heating piping.
  2. All steam condensate return piping shall be run in (SCH 80) black steel.
  3. Fittings shall be standard weight (125 lbs.), cast iron screwed, ASTM A126, Class A, for sizes 1/2" through 2". Piping 2" and under shall be screwed.
  4. Victaulic Grade E couplings, fittings and accessories in conjunction with grooved end schedule 40 piping will be permitted in existing and new construction for hot water heating system.

2.2 PIPE AND FITTINGS:

- A. All fittings on welded lines shall be furnished in accordance with ASTM A105 Specification designed for welding. Branch outlets on mains 2-1/2" and smaller to be made with Weldolets or Thredolets. Welding fittings on mains and branches 3" and larger are to be full size of reducing tube designed for welding. All flanged valves 3" and larger and special equipment connections to be installed with weld neck flanges for welded construction.
- B. All nipples shall be extra strong as follows: Pipe size 1/2" to 4" - 6" close. Pipe size 5" - 12" - 12" close and of the same material as the piping they are used with.
- C. All copper tubing shall be furnished in Type "L" using sweat fittings unless otherwise noted. Copper tubing shall be furnished in Chase, Anaconda, Bridgeport or Revere.
- D. All black steel over 4" or other welded pipe shall have long radius welding ells and tees of the same wall thickness as the pipe. Welding tees will not be required where the mains and branches comply with the following schedule:

<u>Min. Size of Mains</u>	<u>Max. Size of Branch</u>
2 1/2"	3/4"
3"	1 1/4"
4"	2"
5"	3"
6"	4"
8"	6"
10"	8"
12"	10"

**GLASTONBURY FIRE HOUSE  
BOILER REPLACEMENT  
GLASTONBURY, CONNECTICUT**

- E. Welding flanges shall be slip-on or welding neck type, 300 psig forged steel conforming to ANSI Specification B-16.5.
- F. All necessary precautions shall be taken when welding in the new building to prevent combustion of structure.

2.3 GROOVE PIPING:

- A. Victaulic couplings may be used in lieu of welding, thread or flanging on 2 1/2" through 30" carbon steel pipe, on heating water services from -30 deg. F. to 230 deg. F. within the manufacturer's rated working pressures. Pipe grooving shall be cut grooved and/or rolled grooved as per manufacturer's latest spec. Installation is per manufacturer's latest recommendations. All piping shall be Schedule 40. grooved piping shall be used only in concealed or service areas. Grooved piping will not be accepted in finished areas with no ceiling.
- B. Piping Components  

Grooved couplings consisting of two or more pieces of ductile or malleable iron. Coupling gaskets will be a synthetic rubber gasket with a central cavity pressure responsive design. Coupling bolts and nuts shall be heat treated carbon steel, track head conforming to physical properties of ASTM-A-183. All grooved couplings shall be as manufactured by Victaulic Co. Style 77, 07 or equal.
- C. For piping 2 1/2" and larger, full size branch connections shall be made with manufactured grooved end tees. Branch connections for less than full size shall be made with Victaulic hole cut products. Style 920 or Style 921 branch connections with locating collar engaging into hole or style 72 outlet coupling used to join grooved pipe and to create a branch connection.  

Gaskets for branch connection shall be Victaulic Grade "E" EPDM Compound with working temperature of -30 deg. F. to 230 deg. F.
- D. Flanges  

Vic-Flange Style 741 (2-24") for connection to ANSI class 125 and 150 flanged components.
- E. Fittings  

Fittings shall be full flow cast fittings, steel fittings or segmentally welded fittings with grooves or shoulders designed to accept Victaulic grooved end couplings.

  1. Standard Fittings - shall be cast of ductile iron conforming to ASTM A-536 (Grade 65-45-12) or malleable iron conforming to ASTM A-47, Grade 32510, painted with a rust inhibiting modified vinyl Alkyd enamel or hot-dip galvanized to ASTM A-153 or zinc electroplated to ASTM B-633, as required.
  2. Standard Steel Elbow Fittings - (14" - 24"), shall be forged steel conforming to ASTM A-106 Grade B (0.375" wall), painted with rust inhibiting modified vinyl Alkyd enamel or hot-dip galvanized to ASTM A-153.
  3. Standard Segmentally Welded Fittings - shall be factory fabricated, by fitting manufacturer, of carbon steel pipe as follows, 3/4" - 4" conforming to ASTM A-53, Type F; 5" - 6" Sch. 40 conforming to ASTM A-53, Type E or S, Grade B; 8" - 12" Sch. 30 conforming to ASTM A-53, Type E or S, Grade B; 14" - 24" 0.375" wall

**GLASTONBURY FIRE HOUSE  
BOILER REPLACEMENT  
GLASTONBURY, CONNECTICUT**

conforming to ASTM A-53, Type E or S, Grade B, painted with rust inhibiting modified vinyl Alkyd enamel or hot-dip galvanized to ASTM A-153, as required.

- F. Victaulic Pipe Hanging (Victaulic Hanging Standard A-130)
1. Style 07 Zero-Flex for rigid piping systems should be supported as per Building Services B31.9 Hanging.
  2. Style 77 flexible piping systems are supported as per Victaulic Hanging Standard A-130.

2.4 PIPING JOINTS:

- A. Welded Joints shall be fusion welded in accordance with American Standard B31.1, Section 6, except as modified hereinafter. Changes in direction of piping shall be made with welding fittings only. Mitering, notching or direct welding of pipe to the main in order to form tees or ells will not be permitted. Branch connections may be made with welding tees or forced branch outlet fittings, as manufactured by Bonney Forge, either being acceptable without size limitation. Bonney Thredolets shall be used in lieu of Hald couplings when reducing from a welded run to a screwed branch. Outlet fittings where used shall be forged, flared for improved flow where attached to the run, reinforced against external strains and designed to maintain full pipe bursting strength. Fillet welds shall be used for welding screwed and slip-on steel flanges to pipes. Where lateral connections are to be used, either lateral fittings or Bonney Latrolets are acceptable. Wedded joints shall be used in finished areas with no ceiling.
- B. Screwed Joints: The ends of pipes to be threaded shall be cut square and reamed. Pipe threads shall be standard taper, shall be cut straight and clean and to full depth, and shall be free from dirt, chips and burrs when the joint is made. Pipe joint lubricant or compound shall be selected for the pipe line service and shall be applied to male threads only. Screwed joints shall not be caulked.
- C. Flanged Joints: This heading covers flanged joints of all types, including those made with flange unions. Flanged joints shall be made with suitable reinforced gaskets. Clean all parts and align the joint before assembling; support pipes or heavy parts independently. Opposite bolts shall be pulled up successively. Screwed steel flanges shall be welded to pipes; slip-on steel flanges shall be welded front and back.

Cast iron flanges shall not be welded to pipes. If raised face flanges are to be bolted against plain face flanges, the raised face shall be removed and a full face gasket used. Where flanged base elbows are installed, the base shall not be used for anchoring the line or otherwise subjected to tension or shear.

- D. Soldered Joints in Copper Tubing: Cut the ends of tubes square, remove burrs, clean tube ends and fitting sockets with emery cloth and remove all particles before applying flux and making the joint. Insert tubes to full socket depth. Use the following solders at the given conditions.

95 - 5% Tin-Antimony/all services/high pressure 250 degrees F. Max.  
Silver - 35 to 45% alloy-refrigerant piping/high pressure and temperature.

**GLASTONBURY FIRE HOUSE  
BOILER REPLACEMENT  
GLASTONBURY, CONNECTICUT**

2.5 PIPE HANGERS:

- A. Securely hang and anchor pipe as shown and required with proper provision for expansion, contraction and elimination of undue stress and strain on piping.
- B. Provide a pipe hanger within two (2) feet of each elbow, tee, wye, valve, strainer and similar device.
- C. Secure and support runs at base and at sufficiently close intervals to hold pipe at alignment and to carry safely the weight of piping and contents without undue stress thereon.
- D. Except as indicated to the contrary, secure and support all horizontal piping as follows and required to prevent sagging, undue pipe movement and preserve proper alignment in each run.

<u>Piping</u>	<u>Sizes</u>	<u>Maximum Interval</u>
Cast Iron	All sizes	At each hub or joint
Steel	2" & smaller	Six (6) feet
Steel	2 1/2" & larger	Ten (10) feet
Copper Tubing	1 1/4" & smaller	Five (5) feet
Copper Tubing	1 1/2" & larger	Eight (8) feet

- E. Hangers up to and including 2" shall be the adjustable band type equal to Empire. Figure 310 for iron pipe and Fig. 310CT for copper tubing.
- F. Hangers for piping 2-1/2" and up shall be the clevis type, equal to Empire. Figure 11 for iron pipe and Figure 110CT for copper tubing.
- G. Hangers shall be suspended from one of the following devices:
  - 1. "C" clamps.
  - 2. Trapeze hanger assemblies consisting of back-to-back horizontal steel channels with end-type rod hangers.
  - 3. Expansion shield embedded into concrete or masonry.
- H. On hot and chilled water systems, provide over-sized hangers.
- I. Refer to Section 15240 for Seismic Restraints.

2.6 VALVES:

- A. This Contractor shall furnish and install valves where shown on plans and also wherever necessary to make the system complete in its operation. All valves shall be as manufactured by Stockham, Jamesbury, Centerline, Appollo, Milwaukee and Victaulic.

Hot Water Heating and Chilled Water:

2" and smaller  
Ball valves Apollo 71-100/200



**GLASTONBURY FIRE HOUSE  
BOILER REPLACEMENT  
GLASTONBURY, CONNECTICUT**

Check valves	Stockham B-310-T
Vertical check valves	Stockham B-310-T

2-1/2" and larger

Butterfly valves	Stockham - LG712-BS3-B (Lug Style)
Check valves	Centerline - Series 800 S.S. plate and spring, and nypalon seats.

Furnish all valve materials suitable for service intended. No gate valves shall be allowed. Provide all valves with factory installed extension stems.

2.7 UNIONS:

- A. All unions shall be furnished in Nibco-633 or equal in Chase, Revere, Jefferson and Anaconda.

2.8 GASKETS:

- A. Where flanges occur, they shall be packed with Klinger or approved equivalent high quality non-asbestos material composed of fibers for industrial maintenance service with high chemical stability and heat resistance. Nitrile rubber bonded.

Temperature	750 deg. F. max.
Pressure	1450 psi max.
Compressibility	ASTM F36A
Tensile Strength	ASTM F152

2.9 FLOOR AND CEILING PLATES:

- A. Furnish and install satin chrome plated pressed metal floor and ceiling plates on all exposed pipes passing through floors, walls, ceilings, and partitions throughout.

2.10 REAMING OF PIPES:

- A. All pipes to be carefully reamed after cutting and threading.

2.11 PIPE ANCHORS:

- A. Furnish and install all steel clamps around mains not less than 1/4" thick and welded to pipe and necessary angle braces to substantial construction to meet job conditions. Anchored mains shall be properly guided.
- B. Vertical risers, if any, shall be anchored by similar clamps secured to floor, concealed in wall construction.

2.12 EXPANSION LOOPS AND JOINTS:

**GLASTONBURY FIRE HOUSE  
BOILER REPLACEMENT  
GLASTONBURY, CONNECTICUT**

- A. Furnish and install all expansion joints with mains and loops properly anchored and guided to allow for the necessary expansion of mains and all run outs shall be piped to allow for necessary expansion on risers and mains. In cases where space is limited, expansion joints with compensators, guides and anchors may be used in place of expansion loops as approved by the Engineer.
- B. Provide all expansion joints in Keflex or equal in Fulton Syphon, Flexonics or Adscos, with compensator guides and anchors. Piping joints 3" and larger shall be free- flexing type with Type 304 stainless steel bellows and 150-lb. van stone flanges. Lines of 2-1/2" and smaller shall be equipped with Quadra Side H compensators having multi-ply stainless steel bellows, carbon steel thread and shroud, each for 1" compression and 3" extension.
- C. Pipe alignment guides shall be installed in accordance with manufacturer's published bulletin. Anchors shall have sufficient strength to prevent movement of the piping beyond anchor points.

2.13 HANGERS AND SLEEVES:

- A. All horizontal piping shall be supported in a good, firm and substantial manner. No chains, horizontal pieces of pipe or hangers formed by means of perforated steel bands, pipe rings and hooks will be permitted. Provide cast iron ceiling plates for all hangers in finished basement ceilings. All hangers shall be oversized
- B. Furnish and place "Hole-Outs" plastic preformed knockout sleeves for all pipes passing through concrete or tile floors or partitions. All pipes passing through toilet room and mechanical room floors shall be provided with grouted, split Schedule 80 steel pipe sleeves, packed with hair felt and Portland cement to allow for flushing of floors without leakage. All pipes and conduits passing through floors, walls or partitions shall be provided with sleeves sized to give a minimum of 1/2" clearance between sleeve and the outside diameter of the pipe, conduit or insulation, enclosing the pipe or conduit.
- C. Sleeves through concrete floors or interior masonry walls shall be Schedule 40 steel pipe, set flush with finished wall or ceiling surfaces, but extending 2 inches above finished floors or shall be in accordance with details on drawings. In all mechanical equipment rooms or penthouses, sleeves shall extend 6 inches above finished floor.
- D. All outside piping passing through exterior walls, foundation walls and floors shall be furnished with flanged C.I. wall sleeves in Zurn, J.R. Smith or Josam. Furnish with flashing clamp where sleeve passes through waterproof membrane.

2.14 SPECIALTIES FOR HOT WATER SYSTEM:

- A. Furnish and install all hot water equipment in Bell & Gossett as specified below and as shown on the drawings.
  - 1. Expansion tank with bladder shall be furnished on hot water system ASME stamped and designed for 125 lbs. working pressure and 200 deg.F. Test pressure in steel to conform with U-69 construction, precharged to 55 psig. Number of tanks and size shall be shown on drawings. Provide B&G automatic air vents as required.
  - 2. Pressure reducing valve for each closed system.

**GLASTONBURY FIRE HOUSE  
BOILER REPLACEMENT  
GLASTONBURY, CONNECTICUT**

3. B & G Triple Duty flow control valves shall be furnished in either the angle type or straightaway to suit each individual location and full size of each main or branch main.
  4. Furnish all pumps as called for in schedule and following paragraph.
  5. Air eliminator shall be furnished ASME stamped and designed for 125 psig working pressure. Size and capacity shall be shown on drawings.
  6. Provide B&G circuit setter plus calibrated balancing valves Model C.B. on all radiation and air handling equipment.
- B. Furnish and install the following accessories and equipment in make other than Bell & Gossett.
1. Thermometers: Install Ashcroft Fig. 7173T BI-Metal "Every Angle" thermometers where shown and/or called for on plans or in specifications.
  2. Thermometers shall have 5" aluminum hermeticism sealed case with stainless steel stem with 1/2" NPT connection. Install in separable well in brass with lagging extension neck. Stem length and dial range shall be 6" and 0 degrees to 250 degrees F., respectively.
  3. Furnish and install on non-critical systems, gauges suitable for use on hot water where indicated on drawings or called for in specifications. Gauge shall be Ashcroft Fig. 2070 with silver brazed boudon tube, aluminum back flange type epoxy coated case, chrome ring, 1/4" NPT lower connection, stainless steel movement with 1% accuracy. Pressure range shall be as required. Furnish 1/4" needlepoint valve in Crane #88 for each gauge. Where sharp pressure fluctuations may occur, mount gauge on a 1/4" Fig. 1106B pulsation dampener. Provide compound gauges where required or called for.
  4. Furnish and install gauges on all pump discharge and compound gauges on all pump suction.
  5. Furnish and install balancing valves on supply and return mains and branch mains from 1-1/2" and larger.
  6. Expansion fittings shall be provided in Flexonics Type H expansion joints, sized as required to take up all expansion in mains and/or branches or equal in Anaconda.
  7. Furnish and install all balancing valves on radiation, air handling unit coil, fan coil unit coil, cabinet and unit heater coil, etc., runouts 2" and smaller in Tour Andersson STA-D Series with "A metal" construction. Branch mains 2 1/2" and larger shall be provided with Tour Andersson STA-F Series balancing valve.
  8. Furnish and install dielectric fittings.
  9. Furnish and install brass cap with chain on all strainers, drains and hose connections.

2.15 IN-LINE MOUNTED CENTRIFUGAL PUMPS:

- A. Furnish and install the in-line centrifugal pumps complete with motors and trim meeting the performance, size, electrical requirements as scheduled or otherwise specified in Grundfos Magma . Maximum operating temperature shall be 225 degrees F with a maximum working pressure of 175 PSI.
- B. All in-line centrifugal pumps shall be furnished complete with motor and trim suitable for service indicated on plans or otherwise specified. Pump volute shall be of cast iron design. Volute shall include gauge, vent and drain ports. The connection style shall be flanged. The mechanical contractor shall coordinate system connection sizes with trim and pump size and

**GLASTONBURY FIRE HOUSE  
BOILER REPLACEMENT  
GLASTONBURY, CONNECTICUT**

provide all fittings and hardware necessary to connect pump to system piping. . The pump internals shall be capable of being serviced without disturbing piping connections to the pump.

- C. Furnish motors for all in-line centrifugal pumps meeting the electrical requirements scheduled and specified in accordance with specification section 15010.  
  
Motors shall be selected to be non-overloading at any point along the pump curve and shall meet NEMA specifications.
- D. Pumps shall be of the maintainable design. Provide owner with complete parts list with service information.
- E. Each pump shall be factory tested per Hydraulic Institute standards and name-plated prior to shipment. Impeller shall be both hydraulically and dynamically balanced, keyed to the shaft and secured by a locking cap screw or nut.
- F. Each pump shall have a three year warranty from the date of installation.
- G. Each pump shall be factory primed and painted to prevent rust and corrosion of the pump exterior surfaces.
- H. Provide seismic restraints and vibration isolation for each pump in accordance with specification section 15010.
- I. Pump shall be installed, aligned and started in accordance with manufacturer's recommendations

**GLASTONBURY FIRE HOUSE  
BOILER REPLACEMENT  
GLASTONBURY, CONNECTICUT**

2.16 UNIT HEATERS – HORIZONTAL TYPE:

- A. Furnish and install unit heaters as indicated on the plans and as scheduled. Refer to equipment schedule for specific Model, capacity and performance data for each unit. All units shall be installed in a neat and workmanlike manner in accordance with the manufacturer's installation instructions and these specifications. Unit heaters shall be by Modine, Trane or Sterling.
- B. Casing shall be 20 gauge die-formed steel. Casing shall be factory painted. Color as selected by architect.
- C. Coil elements and headers shall be of heavy wall drawn seamless copper tubing. Element tubes shall be brazed into extruded header junctions. Pipe connection saddles shall be cast bronze.

Aluminum fins shall have drawn collars to assure permanent bond with expanded element tubes and exact spacing. All element assemblies are submersion tested at factory to 250 PSI, and are rated at 150 pounds of saturated steam pressure at 366 °F under maximum load conditions.

- D. Motors shall be totally enclosed, resilient mounted with class "B" windings. All motors shall be designed for horizontal mounting. Motors shall have internal thermal overload protection and permanently lubricated bearings. Refer to schedule for motor data such as voltage and power requirements.
- E. Fans shall be of the aluminum blade, steel hub type designed and balanced to assure maximum air delivery, low motor horsepower requirements and quiet operation. Blades shall be spark proof. Units shall be provided with fan and motor guards. Guards shall be welded steel and zinc plated.
- F. Units shall be equipped with horizontal and vertical adjustable louvers for four-way air control.
- G. Furnish each unit heater with a strap-on type hot water aqua-stat for control of fan motor. Set for fan to operate when hot water outlet of unit heater reaches 140 °F.
- H. Provide two or three speed motor and speed switch mounted inside of cabinet.
- I. The cabinet heaters shall be furnished in capacities as shown in schedule on drawings.

2.17 GAS FIRED CONDENSING BOILER:

- A. The BOILER shall be a LOCHINVAR KNIGHT XL Model KBN 399 having a modulating input rating of 399000 Btu/Hr, an output of 324,000 Btu/Hr and shall be operated on Natural Gas . The BOILER shall be capable of full modulation firing down to 20% of rated input with a turndown ratio of 5:1.

**GLASTONBURY FIRE HOUSE  
BOILER REPLACEMENT  
GLASTONBURY, CONNECTICUT**

- B The BOILER shall bear the ASME "H" stamp and shall be National Board listed. There shall be no banding material, bolts, gaskets or "O" rings in the header configuration. The stainless steel combustion chamber shall be designed to drain condensation to the bottom of the heat exchanger assembly. A built-in trap shall allow condensation to drain from the heat exchanger assembly. The complete heat exchanger assembly shall carry a ten (10) year limited warranty.
- C The BOILER shall be certified and listed by C.S.A. International under the latest edition of the harmonized ANSI Z21.13 test standard for the U.S. and Canada. The BOILER shall comply with the energy efficiency requirements of the latest edition of the ASHRAE 90.1 Standard and the minimum efficiency requirements of the latest edition of the ASHRAE 103 Standard. The BOILER shall operate at a minimum of 93.3% thermal efficiency. The BOILER shall be certified for indoor installation.
- D The BOILER shall be constructed with a heavy gauge steel jacket assembly, primed and pre-painted on both sides. The combustion chamber shall be sealed and completely enclosed, independent of the outer jacket assembly, so that integrity of the outer jacket does not affect a proper seal. A burner/flame observation port shall be provided. The burner shall be a premix design and constructed of high temperature stainless steel with a woven metal fiber outer covering to provide modulating firing rates. The BOILER shall be supplied with a gas valve designed with negative pressure regulation and be equipped with a variable speed blower system, to precisely control the fuel/air mixture to provide modulating boiler firing rates for maximum efficiency. The BOILER shall operate in a safe condition at a derated output with gas supply pressures as low as 4 inches of water column.
- E The BOILER shall utilize a 24 VAC control circuit and components. The control system shall have an electronic display for boiler set-up, boiler status, and boiler diagnostics. All components shall be easily accessed and serviceable from the front and top of the jacket. The BOILER shall be equipped with; a temperature/pressure gauge; high limit temperature control with manual reset; ASME certified pressure relief valve; outlet water temperature sensor; return water temperature sensor; flue temperature sensor; flow switch and built-in freeze protection. The BOILER shall be equipped with an outdoor air reset function. The manufacturer shall verify proper operation of the burner, all controls and the heat exchanger by connection to water and venting for a factory fire test prior to shipping.
- F The BOILER shall feature the "Smart System" control with a 2-line, 16 character LCD display, password security, outdoor reset, pump delay with freeze protection, pump exercise and PC port connection. The BOILER shall allow 0-10 VDC input connection for BMS control and have built-in "Cascade" to sequence and rotate while maintaining modulation of up to eight boilers without utilization of an external controller. The BOILER shall be equipped with two terminal strips for electrical connection. A low voltage connection board with 28 data points for safety and operating controls, i.e., Auxiliary Relay, Auxiliary Proving Switch, Manual Reset Low Water Cutoff, Flow Switch, High and Low Gas Pressure switches, Tank Thermostat, Wall Thermostat/Zone Control, System Supply Sensor, Outdoor Sensor, Building Management System signal and Cascade control circuit. A high voltage terminal strip for Supply voltage and independent pump control of the System pump, and the Boiler pump. Supply voltage shall be 120 volt / 60 hertz / single phase.



**GLASTONBURY FIRE HOUSE  
BOILER REPLACEMENT  
GLASTONBURY, CONNECTICUT**

- G The BOILER shall be installed and vented with a direct Vent system with horizontal sidewall termination of both the vent and combustion air. The flue shall be Category IV approved Stainless Steel sealed vent material terminating at the sidewall with the manufacturers specified vent termination. A separate pipe shall supply combustion air directly to the boiler from the outside. The air inlet pipe may be PVC or CPVC sealed pipe. The boiler's total combined air intake length shall not exceed 100 equivalent feet. The boiler's total combined exhaust venting length shall not exceed 100 equivalent feet. The air inlet must terminate on the same sidewall as the exhaust. *Foam Core pipe is not an approved material for exhaust piping.*
- H The BOILER shall have an independent laboratory rating for Oxides of Nitrogen (NO<sub>x</sub>) of 30 ppm or less corrected to 3% O<sub>2</sub>.
- I The BOILER shall operate at altitudes up to 4,500 feet above sea level without additional parts or adjustments.
- J M9 Direct Spark Ignition with Electronic Supervision (Standard)

**PART 3 -EXECUTION**

**3.1 INSTALLATION:**

- A. All piping work shall be installed with proper provision to allow for expansion and contraction of lines so as to prevent any undue strains on pipe and fittings, any trapping of lines or lifting or dislocating of any appliances.

Rectify without cost to the Town any conditions of noisy circulation due to trapped or air bound lines, including the expense of cutting and repairing of the building structure incident to making such alterations.

- B. Install the work to conform to space conditions and the work of other trades. The drawings indicate generally the runs and sizes of piping and, although the size must not be decreased, nor the drawings deviated from, except as unforeseen space conditions may require, the right is reversed to make minor changes in the arrangement of the work to meet conditions arising during construction.

**3.2 MISCELLANEOUS PIPING**

- A. Connect to the overhead steam condensate and cold water lines in the Mechanical Equipment Room, connecting up pressure reducing valve and relief valves on system as shown on diagrams.

**3.3 TESTING**

- A. All flow piping shall be tested and made tight.
- B. All piping shall be tested and made tight at 100 psi or 50 psi above the city pressure before any piping is concealed or approved.

**GLASTONBURY FIRE HOUSE  
BOILER REPLACEMENT  
GLASTONBURY, CONNECTICUT**

- C. After the system is thoroughly cleaned, it shall be put into operation by this Contractor. All parts of the system shall be thoroughly tested and this Contractor shall carefully instruct the University's authorized representative as to the proper operation and care of the entire system.
- D. All low pressure piping shall be tested and made tight at 100 lbs. per square inch hydrostatic pressure before any piping is concealed or covered.
- E. Contractor shall waste all returns for a minimum period of two weeks after all steam lines, return lines and heating surfaces have been connected up and in operation or until all traces of grease, oil and dirt disappear.
- F. After the systems are thoroughly cleaned, they shall be put into operation by the Heating Contractor after all traps and strainers have been removed and cleaned. All parts of the system shall be thoroughly tested and this Contractor shall carefully instruct the University's authorized representatives as to the proper operation and care of the entire system.

**3.4 FLUSHING OUT SYSTEM**

- A. Contractor shall flush out the systems before start-up.

END OF SECTION 15700

PART 1 - GENERAL

1.1 RELATED DOCUMENTS:

- A. The General Provisions of the Contract, including General and Supplementary Conditions and General Requirements, apply to the work specified in this Section.
- B. The General Requirements in Section 15010 shall also govern the work under this Section.
- C. Examine all drawings and data and coordinate the work of this Section with all related and adjoining work.

1.2 SCOPE OF WORK:

- A. Provide all labor, materials, equipment and tools required to complete the work described and shown on the contract drawings.

PART 2 - PRODUCTS

2.1 PRODUCTS:

- A. None required.

PART 3 - EXECUTION

3.1 GENERAL:

- A. Work shall be performed only by a firm which employs certified testing, adjusting and balancing technicians as listed by the Sheet Metal Industry National Certification Board of TAB Technicians. The work may be performed by a certified Test, Adjusting and Balancing technician who may be assisted by other TAB technicians. This firm shall provide personnel trained and experienced in system balancing. This requirement will not be waived under any condition.
- B. Before submitting system performance data for approval or acceptance, the firm shall perform all necessary tests and make all necessary adjustments as required to obtain the flow as called for on the Contract Documents.
- C. The balance reports shall include the names, signatures and registration numbers of the technicians assigned to the project.

3.2 ACCEPTABLE FIRMS:

- A. The following listed firms are approved to perform this work:

Wing's Testing and Balancing  
RK Wing Company  
James Brennan Company  
Technical Associates Group, Inc.  
Environmental Testing and Balance

- B. Request to employ any other balancing and testing firm must be accompanied by a complete brochure of the firm listing previous installations successfully balanced, length of time in business, names and qualifications of employees and list of instruments available for use on the project.

3.3 HYDRONIC SYSTEMS:

- A. Prior to the start of balancing, the firm shall check the rotation of all pumps.
- B. The firm shall compile the following data for each pump insofar as they apply and shall include it on the final submittal:

PUMP DESCRIPTIVE DATA

Pump Number  
System Served  
Pump Size  
Pump Make  
Pump Horsepower  
Motor Safety Factor  
Motor Manufacturer & Size  
Voltage & Phase

PUMP DESIGN & DELIVERED CONDITIONS

Pump Rpm  
Pump Inlet & Outlet Pressure  
Amperage  
Brake Horsepower  
Gpm Supply

SYSTEM DESIGN & DELIVERED CONDITIONS

Flow (Gpm) through each pump  
Inlet & Outlet temperature at 3-way valve  
Flow (Gpm) through each coil  
Inlet & Outlet Pressure at each coil  
Inlet & Outlet temperature at each coil  
Type of instrument and method used

**GLASTONBURY FIRE HOUSE  
BOILER REPLACEMENT  
GLASTONBURY, CONNECTICUT**

3.5 **INSTALLATION TOLERANCES:**

- A. Adjust heating system to the following tolerances:
1. Supply water temperature 80 degree F to 120 deg. F 0% to +10% of design value.
  2. Supply water temperature 120 degree F to 160 deg. F -5% to +10% of design value.
  3. Supply water temperature above 160 degree F -10% to +10% of design value.

3.4 **FIELD VERIFICATION:**

- A. The design Engineer may request verification of data contained in the balancing report. If requested the TAB technician whose initials appear on the data sheets shall take outlet and inlet readings selected at random by the Engineer who will compare these readings to those in the submitted report. If the field verification is not satisfactory, the firm doing the TAB work shall completely rebalance the system and a new report shall be prepared and submitted for approval.

END OF SECTION 15950

SECTION 16000

GENERAL ELECTRICAL

PART 1 - GENERAL

1.1 RELATED DOCUMENTS:

- A. The General Provisions of the Contract, including General and Supplementary Conditions and Division 1, General Requirements, apply to the work specified in this Section.
- B. Section 16000, General Electrical, shall govern the work under all Sections of Division 16.

1.2 DESCRIPTION:

- A. Work Included: The electrical work shall consist of all labor, equipment and services required to complete, ready for correct operation, all of the work called for by the accompanying drawings and these specifications.
- B. The work shall include, but is not limited to:
  - 1. Demolition.
  - 2. Raceways and Boxes.
  - 3. Branch Circuit Wiring.
  - 4. Wiring Devices.
  - 5. Circuit Breakers.

1.3 SITE CONDITIONS:

- A. Prior to submitting bid, visit the site and identify existing conditions and difficulties that will affect work called for by the Contract Documents.
- B. No compensation will be granted for additional work caused by unfamiliarity with site conditions that are visible or readily construed by experienced observers. Include in the bid amount all demolition work required.
- C. The Contractor shall verify and obtain all necessary dimensions at the site.

1.4 DEFINITIONS:

- A. Furnish: The word "furnish" is used to mean "supply and deliver the referenced item to the project site, ready for unloading, unpacking, assembly, and installation".
- B. Install: The word "install" is used to describe operations at the project site involving the referenced item including the actual "unloading, unpacking, assembly, erection, placing, anchoring, applying, working to dimension, finishing, curing, protecting, cleaning, and similar operations".



**GLASTONBURY FIRE HOUSE  
BOILER REPLACEMENT  
GLASTONBURY, CONNECTICUT**

- C. Normally Occupied: The words "normally occupied" are used to mean "all rooms within a building except for crawlspaces, underground tunnels, attic spaces, mechanical rooms, telephone rooms, data distribution rooms, and electrical rooms".
- D. Or Approved Equal: The words "or approved equal" are used to mean "any product which in the opinion of the Engineer is essentially equal in quality, size, arrangement, appearance, construction, and performance to that product specified or shown on the drawings".
- E. Provide: The word "provide" means "to furnish and install the referenced item, complete and ready for the intended use".
- F. Remove: The word "remove" means "to disconnect from its present position, remove from the project site, and to dispose of in a legal manner".

**1.5 QUALITY ASSURANCE:**

**A. Codes and Standards**

- 1. All work under this section shall comply with the applicable requirements of the National Electrical Code, local electrical and other codes, laws, regulations and standards including those of all state authorities. Where references are made in laws codes regulation and standards, these documents, including the latest revisions and amendments in effect as of the date of bid opening, shall form part of these specifications. Upon completion of the work, the contractor shall furnish Certificates of Approval from the local inspection authorities having jurisdiction for approving materials, equipment, installation pertaining to the electrical work as may be required by the local and/or state authority for the issuance of a permanent Certificate of Occupancy. All expenses arising from the procurement of these Certifications shall be paid by the contractor and shall be included in the lump sum contract price.
- 2. Codes enforced at time at time of bidding include: 2009 Amendment to the 2005 Connecticut State Building Code Supplement, 2003 IBC, 2005 Connecticut Fire Code Supplement, 2005 National Electrical Code, ICC/ANSI A117.1-2003, Accessible and Usable Buildings and Facilities, ADA, and 2003 International Energy Conservation Code(IECC).

**B. Submittals**

- 1. The contractor shall submit for approval a complete list of materials, fixtures and equipment to be incorporated in the work. The list shall include manufacturer's names and catalog numbers, descriptive data, manufacturer's ratings and application recommendations, cuts, diagrams, performance curves and such other information as may be required by the Owner to judge compliance with the requirements of the contract and suitability to the application. Items on the list shall be clearly identified as to proposed application. Approval of materials and equipment will be based on manufacturer's published ratings. Submittal procedures shall be in accordance with Division 1 of these specifications.

**GLASTONBURY FIRE HOUSE  
BOILER REPLACEMENT  
GLASTONBURY, CONNECTICUT**

2. When directed by the Owner, the contractor shall submit in approved form for record, a Certificate of Compliance with a cited code or standard for the designated materials and equipment; such certificates may be accepted in lieu of samples. Any materials or equipment submitted for approval, which are not in accordance with the specifications requirements may be rejected.
3. As part of the coordination work required of the contractor, installation drawings shall be prepared by the contractor as necessary. It is intended that these drawings be used to coordinate the work of the various trades and to clarify details of proposed assembly, erection and installation. Installation drawings shall be prepared when indicated in these specifications or on the electrical drawings, or when directed by the Owner for comment or approval when an installation condition or problem arises which the contractor wishes the Owner to review. All installation drawings submitted for review will be considered and treated as shop drawings and the requirements pertaining to shop drawings shall govern.

C. Equipment alternates, substitutions, and deviations:

1. Wherever more than one manufacturer is mentioned in the specifications or on the drawings, any of those named shall be considered equally acceptable to that on upon which design was based, and providing all aspects of the specification are met insofar as quality, construction, performance, space requirements, noise levels and special accessories or materials, any of those named may be included in Contractor's bid.
2. Bidders wishing to obtain approval on brands other than those specified by name shall submit their request to the Architect and Engineer not less than ten (10) business days before the date fixed for opening of bids. Approval by the Architect and Engineer will be in the form of an Addendum to the specifications issued to all prospective bidders, indicating that the additional brand or brands are approved as equal to those specified so far as the requirements of the project are concerned.
3. Wherever a single manufacturer is used in the specifications or on the drawings and is followed by the words "or approved equal" the Contractor must use the item named or he may apply for an alternate equipment deviation through the prescribed manner in accordance with Item 1.6, I, 2.
4. Alternate equipment to that specified or shown on the drawings, as proposed to be provided by the contractor, must be essentially equal in quality, size, construction, and performance to that item specified or shown on the drawings.
5. Submittals for alternate equipment shall list all deviations and differences from the specified equipment. Failure to submit this list will result in rejection of the submittal.

Any deviations and differences not listed but discovered after installation shall be rectified as directed by the Engineer at the Contractor's cost.

6. Furnish samples of alternate equipment proposed to be provided when so requested by the Architect or Engineer.

**GLASTONBURY FIRE HOUSE  
BOILER REPLACEMENT  
GLASTONBURY, CONNECTICUT**

7. Where the Contractor proposes to use an item of equipment which differs from that upon which design was based, which requires any redesign of the structure, partitions, foundations, piping, wiring or of any other part of Mechanical, Electrical or Architectural Layout, all such redesign, new drawings or detailing required shall be prepared by Contractor at his own expense for approval of the Architect and Engineer.
  8. Where approved substitutions or deviations require a different quantity, size or arrangement of structural supports, wiring, conduit, piping, ductwork, and equipment from that upon which design was based, all additional items required by the systems shall, with the approval of the Architect and Engineer, be furnished by Contractor at no additional cost to Owner.
- D. Allow sufficient time so that the delivery and installation of equipment will not be delayed as a result of the time required to review, process and transmit submittals, including resubmittals. Failure by the Contractor to transmit submittals to the Architect and Engineer in ample time for review and processing shall not entitle him to an extension of the Contract Time and no claim for an extension of time by reason of such default will be allowed.
- E. Submittals, shop drawings, and samples will be reviewed with reasonable promptness and will be stamped indicating appropriate action as follows:
1. “No Exceptions Taken” means that fabrication, manufacture, or construction may proceed providing submittal complies with contract documents.
  2. “Amend as Noted” means that fabrication, manufacture, or construction may proceed, providing the submittal complies with Engineer’s notations and contract documents.
  3. “Resubmit” means that submittal, or equipment proposed to be provided, does not comply fully with the contract documents and that fabrication, manufacture, or construction shall not proceed. Resubmit in accordance with the Engineer’s notations and contract documents.
  4. “Rejected” means that submittal does not comply with contract documents, or that equipment proposed to be provided does not comply with the specified requirements or is not equal or better in quality and performance than that item specified. Fabrication, manufacture, or construction shall not proceed. Resubmit in accordance with the contract documents and specified requirements.
- F. If material or equipment is installed prior to review, or without review, it shall be removed and replaced at no extra charge to the Owner if, in the opinion of the Architect and Engineer, the material or equipment is not in compliance with the Contract Documents.
- G. Record Drawings
1. The contractor shall maintain an accurate record of all deviations in work as actually installed from work as indicated. This record shall be kept current and shall be kept available at the site for inspection. Upon completion of the work, and before final payment is authorized, marked prints with signed certifications of accuracy shall be delivered to the architect.
- H. Manuals

**GLASTONBURY FIRE HOUSE  
BOILER REPLACEMENT  
GLASTONBURY, CONNECTICUT**

1. The contractor shall furnish to the Owner operating and maintenance instructions for each piece of equipment and each device.
2. The instructions shall provide detailed descriptions of the operation and maintenance of the equipment or device and shall include manufacturer's literature, detailed wiring diagrams, device internal wiring diagrams, characteristics curves and graphs, data sheets and descriptive literature. The instructions shall be furnished to the Owner 30 days prior to the completion of the building work.

I. Product Handling

1. All work, materials and equipment, whether incorporated into the building or not, shall be protected from damage due to moisture, dirt, plaster, concrete, or from carelessness.
2. All material and equipment which is damaged, including installed work, shall be repaired or replaced to the satisfaction of the Owner.
3. After work is complete, all equipment, including switchboards, transformers, panelboards, lighting fixtures and lamps, shall be cleaned of all construction dirt.

1.6 INTENT OF SPECIFICATIONS:

- A. It is the intent of these Specifications each subcontractor or equipment suppliers to furnish all equipment complete with all motors, drives and magnetic starters throughout for all equipment furnished under these specifications. The above shall also apply to any additions to this Contract, either as covered by and Addenda or Change Orders.
- B. The Electrical Contractor shall provide overload and short circuit protection for all motors unless provided by equipment supplier for packaged type equipment.

1.7 GUARANTEE FOR EQUIPMENT AND SYSTEMS:

- A. Refer to Division 1 of the Architectural Section of Specifications.
- B. The entire Electrical System included under this Section of the Specifications shall be guaranteed by this Contractor against original defects of equipment and workmanship for a period of 12 months from date of acceptance, unless otherwise specified.

1.8 CUTTING AND PATCHING:

- A. Cutting and patching for all electrical work inside building shall be done in accordance with Division 1.

1.9 SLEEVES AND OPENINGS:

**GLASTONBURY FIRE HOUSE  
BOILER REPLACEMENT  
GLASTONBURY, CONNECTICUT**

- A. This Electrical Contractor shall furnish and install all necessary sleeves and openings as required to permit the installation of the electrical systems.

**1.10 ACCESS PANELS:**

- A. Provide access panels to make all junction and pull boxes accessible as required by The National Electrical Code.

**1.11 PAINTING:**

- A. All painting of electrical work will be done in accordance with Division 9 unless otherwise specified.

**1.12 RUBBISH AND CLEANING:**

- A. This Contractor shall be responsible for removal of all rubbish and trash created by the installation of the electrical systems and equipment from the job site. Contractor shall sweep clean all areas.

**1.14 INSTRUCTIONS:**

- A. The Superintendent of the electrical work for this particular project shall spend all necessary time required to instruct the custodians of the building, together with representatives from the Maintenance Department, in the installation including all special controls and devices installed or connected under this contract.

**1.15 POWER SHUTDOWNS:**

- A. Any power shutdown required for the completion of the electrical work shall be scheduled with the owner at least ten working days in advance and shall be done at owner's convenience.

**1.17 SEISMIC:**

- A. Provide seismic restraining devices on all required items of electrical equipment in accordance with ICC Chapter 16. Refer to specification Section 15010 and details on mechanical drawings.

END OF SECTION 16000

SECTION 16060

BASIC ELECTRICAL MATERIALS & METHODS

PART 1 - GENERAL

1.1 RELATED DOCUMENTS:

- A. The Bidding Requirements, Contract Forms and Conditions of the Contract, including General Conditions of the Contract for Construction, and Division 1 - General Requirements, apply to the work specified in this Section.
- B. Section 16000, General Electrical, shall also govern the work under this Section..
- C. This Section includes requirements that are binding on other Sections of Division 16.

1.2 SCOPE:

- A. Scope of work consists of installation of materials to be furnished under this Section, and without limiting generality thereof consists of furnishing labor, materials, equipment, hoisting, plant, transportation, rigging, staging, appurtenances, and services necessary and/or incidental to properly complete all electrical work as shown on the drawings, as described in these specifications or as reasonably inferred from either as being required in opinion of the Owner.
- B. Work Included: Provide complete electrical services where shown on the drawings, as specified herein and as needed for a complete and proper installation including but not necessarily limited to:
  - 1. General
  - 2. Conduits & Raceways
  - 3. Identification
  - 4. Wire and Cables
  - 5. Wiring Devices
  - 6. Outlet Boxes, Junction Boxes, Pull Boxes
  - 7. Supporting Devices
  - 8. Disconnect Switches
  - 9. Grounding.
  - 10. Circuit Breakers.

1.3 QUALITY ASSURANCE:

- A. Refer to Section 16000.

1.4 SUBMITTALS:

- A. Shop Drawings: Submit for all items listed in Paragraph 1.2.B.

PART 2 - PRODUCTS

2.1 GENERAL:

- A. Provide only materials that are new and of type and quality specified, or approved equal. Where Underwriters' Laboratories, Inc. have established standards for such materials, provide only materials bearing the UL label.
- B. Provide materials and equipment necessary to make installation complete in every detail, and to conform to manufacturers' latest installation instructions, under this contract whether or not specifically shown on drawings or specified herein.

2.2 TEMPORARY FACILITIES:

- A. Refer to the requirements of Division 1 regarding temporary facilities.
- B. Scaffolding and other temporary construction shall be rigidly built in accordance with Local and State requirements. Remove from premises upon completion of work.
- C. Provide temporary construction required for electrical work as directed by the Owner.

2.3 RACEWAYS:

- A. Electrical Metallic Tubing:
  - 1. Shall be manufactured from high grade mild strip steel, shall be hot dipped galvanized, and shall be chromated and lacquered to form additional protective layer. EMT conduit shall conform to UL 797 and ANSI C80.3 and shall be as manufactured by Allied Tube and Conduit, or approved equal.
  - 2. Connectors and couplings shall be galvanized steel set screw type. Provide gland compression type couplings and connectors for exposed work in wet locations.
  - 3. Shall be used all branch circuit wiring.
- B. Flexible Steel Conduit:
  - 1. Shall be manufactured from high grade strip steel and shall be hot dipped in a molten zinc bath. The steel strip shall be formed into interlocking convolutions that are continuously joined, metal to metal, assuring continuous grounding contact. Flexible steel conduit shall be UL listed and shall be as manufactured by AFC Cable Systems, or approved equal.
  - 2. May be used in short lengths where EMT cannot be installed due to interferences and obstacles.
  - 3. Provide for final connections to motor driven equipment or where subject to vibration.
- C. Liquidtight Flexible Steel Conduit:
  - 1. Shall be similar to flexible steel conduit, but with pressure-extruded moisture and oil-proof outer jacket of gray polyvinyl chloride plastic. Liquidtight flexible steel conduit shall be UL listed (UL 360) and shall be as manufactured by AFC Cable Systems, or approved equal.



**GLASTONBURY FIRE HOUSE  
BOILER REPLACEMENT  
GLASTONBURY, CONNECTICUT**

2. Fittings, couplings and connectors shall be hot dipped galvanized and threaded, liquidtight type.
3. Provide where located outdoors or in damp or wet areas for final connections to motor driven equipment or where subject to vibration.

2.4 IDENTIFICATION:

- A. Identify all junction boxes and pull boxes installed above ceilings and in unfinished spaces with branch circuit designations. Identification shall be done with black felt tip permanent marker in a neat and readily legible manner.

2.5 SAFETY SWITCHES:

- A. Furnish and install disconnect switches where shown on the drawings..

2.6 CONDUCTORS:

- A. All branch circuit conductors shall be copper rated 600 volts, 90 deg. C., Type THWN-2.
- B. Grounding electrode conductors and bonding conductors shall be soft drawn copper, ASTM B3 solid bare copper for sizes smaller than #8AWG, ASTM B8 stranded bare copper for sizes #8AWG and larger.
- C. Minimum gauge conductors for power and lighting shall be #12 AWG. Increase to #10 AWG for runs exceeding 75'-0", and #8AWG for runs exceeding 150'-0".
- D. Wire Size #8 AWG and larger shall be stranded. Wire of size smaller than #8 AWG shall be solid.
- E. Wire and cable conductors shall be soft drawn copper with conductivity of not less than 98 percent of ANSI Standard for annealed copper. Aluminum conductors shall not be used.

2.7 OUTLET, JUNCTION AND PULL BOXES:

- A. Provide outlet boxes as required for a complete installation.
- B. Outlet boxes shall be code gauge galvanized steel and shall be of shapes and sizes to suit their respective locations and installations, and shall be provided with covers to suite their function and installation. Outlet boxes shall be equipped with fixture stud or straps where required.
- C. The minimum box size for all wall outlet boxes shall be nominal 4" square x 2 1/8" deep (2-gang). Provide larger size outlet boxes, or gangable type boxes where required for the installation.
- D. For exposed work in normally unoccupied (unfinished) areas, provide pressed steel boxes with galvanized or cadmium plated steel covers with rounded corners. Provide cast boxes for work exposed to wet locations and where called for on the drawings.
- E. For above ground pull boxes, provide galvanized code-gauge sheet steel units with screwed on covers, of size and shape required to accommodate wires without crowding, and to suit the location. Provide pull boxes as specified herein, as required for job conditions, and as follows:

**GLASTONBURY FIRE HOUSE  
BOILER REPLACEMENT  
GLASTONBURY, CONNECTICUT**

1. Indoors: NEMA Type 1.
  2. Outdoors or Damp or Wet Locations: NEMA Type 3R.
  3. Hosedown and Splashing Water Locations: NEMA Type 4.
- H. Wireways shall be code gauge galvanized steel, manufactured standard sections and fittings, with hinged and/or screw covers, indoors NEMA Type 1/Outdoors NEMA Type 3R. Wireways shall be sized to code conductor fill requirements and shall be provided as required for job conditions.

**2.8 WIRING DEVICES:**

- A. All devices shall be furnished in Hubbell or approved equal in Pass & Seymour, or Leviton. Devices specified herein are based on Hubbell unless otherwise noted.
- B. Lighting Switches:
1. Toggle Type: Institutional Heavy Duty specification grade, flush mounting, quiet operation AC type with abuse resistant colored nylon toggle operator, heat resistant composition plastic housing, silver cadmium oxide contacts and copper alloy spring contact arm. Rated at 120-277 VAC, capable of full capacity on tungsten or fluorescent lamp load. Designed for side or back wiring with up to No. 10 wire, and with #8 brass terminal screws.

	<u>20 AMP</u>	<u>30 AMP</u>
Single Pole	#HBL1221	#HBL3031
Two Pole	#HBL1222	#HBL3032
Three way	#HBL1223	#HBL3033
Four way	#HBL1224	-

- C. Receptacles:
1. Duplex convenience receptacles shall be heavy duty specification grade, 2 pole, 3 wire grounding, NEMA 5-20R, rated 20AMP at 125 Volts AC.
  2. Receptacles shall have a one-piece nickel plated brass wrap around mounting strap with integral ground contacts and ground tension retaining clips, tandem bypass contact, heat resistant thermoplastic rynite base, and high impact thermoplastic polyester face. Receptacles shall be back and side wired, shall have a back wired green ground terminal, automatic ground clip, and threaded bronze square head center rivet assembly. Duplex Receptacle #HBL5362
  3. Ground Fault Duplex convenience receptacles shall be heavy duty specification grade, 2 pole, 3 wire grounding, NEMA 5-20R, rated 20AMP at 125 volts AC. Receptacles shall have a solid brass wrap around mounting strap with pre-tensioned ground contacts, tandem modified bypass contacts, all glass circuit board with conformal coating for superior moisture immunity, 7 noise filtering capacitors, heat resistant thermoplastic base and high impact nylon face. Receptacles shall be side wired and shall have a green ground terminal. Duplex GFCI Receptacle #GF5362.
- D. Cover Plates:

**GLASTONBURY FIRE HOUSE  
BOILER REPLACEMENT  
GLASTONBURY, CONNECTICUT**

1. Cover plates shall be specification grade non-magnetic Type 302 stainless steel, brushed finish. Where multiple devices are ganged together they shall be mounted under a common cover plate. Provide switch and receptacle combination plates where switches and receptacles are located together. Cover plates shall be furnished in same Manufacturer as devices.

2.9 CIRCUIT BREAKERS:

- A. Provide circuit breakers as noted on the drawings.

2.10 ACCESS PANELS:

- A. Provide access panels for electrical equipment and wiring splices which are not readily accessible. This includes electrical equipment and wiring splices installed above hung ceilings which are not readily removable, within walls, inside chases, or inside dead cavity spaces.
- B. Access panels shall be prime painted steel, with screwdriver lock, shall bear the same fire rating as the wall or ceiling in which they are installed, and shall be of sufficient size for wiring splice access or electrical equipment removal and replacement.

Access panels shall be provided in Milcor manufacture, or approved equal. Provide Milcor Type A in acoustical tile surfaces, Type K for plastered surfaces, and Type M for masonry construction.

2.11 OTHER MATERIALS:

- A. Provide other materials, not specifically described but required for a complete and proper installation, as selected by the contractor subject to the approval of the engineer.

PART 3 - EXECUTION

3.1 GENERAL:

- A. Unless specifically noted or shown otherwise, install all equipment and material specified herein or shown on drawings whether or not specifically itemized herein. PART 3 covers particular installation methods and requirements peculiar to certain items and classes of materials and equipment.
- B. Examine the areas and conditions under which work of this Section will be performed. Correct conditions detrimental to timely and proper completion of the work. Do not proceed until satisfactory conditions are corrected.
- C. The electrical drawings are diagrammatic, but are required to be followed as closely as actual construction and work of other trades will permit. Where deviations are required to conform with actual construction and the work of the other trades, make such deviations without additional cost to the Owner.
- D. Data indicated on the drawings and in these specifications are as exact as could be secured, but their absolute accuracy is not warranted. The exact locations, distances, levels and other conditions will be governed by actual construction and the drawings and specifications should be used only for guidance in such regard.

**GLASTONBURY FIRE HOUSE  
BOILER REPLACEMENT  
GLASTONBURY, CONNECTICUT**

- E. Verify all measurements at the building. No extra compensation will be allowed because of differences between work shown on the drawings and actual measurements at the site of construction.
- F. Do not scale drawings. Scale indicated on drawings is for establishing reference points only. Actual field conditions shall govern all dimensions.
- G. Coordinate:
  - 1. Coordinate as necessary with other trades to assure proper and adequate provisions in the work of those trades for interface with the work of this Section.
  - 2. Coordinate delivery of electrical equipment to project prior to installation. Equipment stored for an extended period of time prior to installation may be subject to rejection by Architect.
  - 3. Coordinate the installation of electrical items with the schedule for work of other trades to prevent unnecessary delays in the total work.
  - 4. Where electrical items are shown in conflict with locations of structural members and mechanical or other equipment, provide required supports and wiring to clear the encroachment.
  - 5. Prior to roughing, the contractor shall obtain exact fixture and device locations from the Architect. Outlet and fixture locations shown on the drawings are to be used for general reference only. Roughing of fixtures and outlets shall not proceed until exact locations, heights, and orientations of fixtures and outlets have been agreed upon with the Architect and Owner.
  - 6. Arrange installation to provide access to equipment for easy maintenance and repair.

**3.2 INSTALLATION OF RACEWAYS AND FITTINGS:**

- A. Install wire and cable in approved raceways as specified and as approved by authorities having jurisdiction.
- B. All conduits shall be concealed from view above ceilings, in chases, and in walls. Conduits may only be installed exposed to view in mechanical and electrical rooms and where run overhead in rooms without ceilings.
- C. Run conduit and cable parallel to or at right angles with lines of the building, to present a neat appearance.
  - 1. Make bends with standard conduit elbows or conduit bent to not less than the same radius.
  - 2. Make bends free from dents and flattening.
- D. Provide code sized conduit unless a larger size is shown on the drawings or specified herein. Minimum size shall be  $\frac{3}{4}$ ".
- E. Securely and rigidly support conduit throughout the work with approved conduit clips and hangers all in conformance with code seismic requirements.
  - 1. Do not use mechanics wire for supporting conduit.
  - 2. Do not support conduits on hung ceilings or from mechanical or electrical equipment.

**GLASTONBURY FIRE HOUSE  
BOILER REPLACEMENT  
GLASTONBURY, CONNECTICUT**

3. Steel supports and racks shall be galvanized steel channel and fittings, unistrut or approved equal.
  4. Provide clamps and support rods as required.
  5. Steel support rods or support bolts for conduits shall be 1/8 inch diameter for each inch or fraction thereof of diameter of conduit size, but no rod or bolt shall be less than 1/4" in diameter.
  6. Horizontal and vertical conduit supports shall not be more than 10' apart or more than 1' from any fitting.
- F. Do not install conduit runs exposed on the building exterior.
- G. Maintain at least 3" clearance between conduits and heating pipes when running parallel to these pipes, and at least 1" clearance when running perpendicular to these pipes.
- H. Provide double locknuts on all conduits terminating in sheet metal enclosures.
- I. Provide expansion couplings for rigid metallic and non-metallic conduits where such conduits are subject to thermal expansion and contraction.
- J. Provide full wall steel flexible conduit for all conduit penetrations through fire walls. Full wall steel flexible conduit shall be 3-hour through penetration fire wall rated and shall be as manufactured by AFC Cable Systems, or approved equal.
- K. Provide necessary sleeves and chases where conduits and cables pass through floors, walls, ceilings, and roofs, and provide other necessary openings and spaces, all arranged for in proper time to prevent unnecessary cutting. Perform cutting and patching in accordance with the provisions for the original work.
- L. Provide offsets prior to entrance into outlet boxes and other electrical equipment for proper adjustment to finished building surfaces.
- M. Seal around all conduit and cable penetrations through fire rated walls and ceilings with 3M Brand CP25N/S fire barrier caulking.
- N. Carefully clean and dry all conduit before installation of conductors. Plug conduit ends to exclude dust, moisture, plaster, or mortar while building is under construction. Lubricants or cleaning agents which might have deleterious effect on conductor coverings shall not be used for drawing conductors into raceways.
- O. All wiring shall be installed in electrical metallic tubing unless otherwise specified herein or called for on the drawings.

**3.3 SLEEVES:**

- A. Provide EMT sleeves for each conduit and cable passing through walls, partitions, and floors.
1. Set pipe sleeves in place before wall, floor, or partition is finished. Seal between sleeves and wall, partition, or floor.
  2. Support conduit and cable free from sleeves.

**GLASTONBURY FIRE HOUSE  
BOILER REPLACEMENT  
GLASTONBURY, CONNECTICUT**

3. Provide sleeves two pipe sizes larger than the conduit or cable passing through, or provide a minimum of ½" clearance.
- B. Caulk the space between sleeve and conduit or cable using 3M Brand OP25N/S fire barrier caulking.
- C. Fireproof all penetrations made in fire rated walls or floors with UL approved materials to prevent passage of fire and smoke and maintain original fire rating of floors or walls.
- D. Provide chrome plated escutcheon plates for each sleeve where exposed to view in finished areas.

**3.4 CONDUCTOR INSTALLATION:**

A. General:

1. The interior of all conduits shall be cleared of burrs, moisture, dirt and obstructions before wires are pulled.
2. Lubricant for pulling wires shall be inert to cable and conduit, shall not in any way restrict ease of pulling through conduit with passage of time, and shall be special lubricant designed specifically for cable pulling and shall be chemically compatible with cable.

B. Color Coding:

1. Consistent phase identification of all conductors shall be maintained as follows:

	<u>120/208V</u>
Phase A	Black
Phase B	Red
Phase C	Blue
Neutral Wire	White

Provide colored plastic tape of specified color code identification for large size conductors available only in black. Wrap tape three complete turns around conductor, at ends and at connections and splices. Provide same color coding for switch legs as corresponding phase conductor.

C. Minimum Conductor Sizes:

1. The minimum branch circuit conductor size shall be #12AWG. Provide #10AWG conductors for branch circuits where the conductor run exceeds 75 feet, and #8AWG conductors where the conductor run exceeds 150 feet.

- D. Provide the number of conductors required for a given branch circuit, or as required for circuitry, whether indicated on the drawings or not.

E. Neutral Conductors:

**GLASTONBURY FIRE HOUSE  
BOILER REPLACEMENT  
GLASTONBURY, CONNECTICUT**

1. All branch circuits shall be installed with a separate neutral conductor. Shared neutrals for groups of branch circuits shall not be permitted.
- F. Provide each circuit with a dedicated ground wire. Use #12 minimum size.
- G. Identify conductors passing through pull boxes, junction boxes, and wireways to indicate circuit designation. Identify pull boxes and junction boxes as specified herein.
- H. Branch circuit wiring and arrangement of home runs have been designed for maximum economy consistent with adequate sizing for voltage drops, circuit ampacities and other considerations.
1. Install the wiring with circuits arranged as shown on the drawings, except as otherwise approved in advance by the Architect and Engineer.
  2. Do not make changes and rearrange circuits without prior approval.
  3. If more than 3 current carrying conductors are installed in one conduit they shall be derated in accordance with the National Electric Code.
  4. Do not install more than three 30 Amp single phase or four 20 Amp single phase circuits in the same conduit. Do not run emergency and normal power wiring in the same conduit.
- I. Splices and Connections:
1. Makes splices electrically and mechanically secure with pressure-type connectors.
    - a. For wires size #8AWG and smaller, provide solderless, screw-on connectors, "Scotch-Lock" or equal, 600V rating, of size and type to manufacturer's recommendation, with temperature ratings equal to the conductor insulation.
    - b. Make splices and terminations to conductors #6AWG and larger with corrosion-resistant, high conductivity, pressure indent, hex screw or bolt clamp connectors, with or without tongues, designed specifically for intended service.
  2. Insulate splices with a minimum of two layers of scotch brand No. 33 vinyl-plastic electrical tape where insulation is required.
  3. Tape joints as required with rubber tape 1 ½ times the thickness of the conductor insulation, then cover with the vinyl-plastic electrical tape specified above.
  4. Provide high conductivity copper alloy bolt-on lugs with pressure plate and socket set screw or hex head screw to attach wire and cable to disconnect switches, transformers, and other electrical equipment as required.

**3.5 OUTLET BOXES:**

- A. All outlet boxes in finished areas shall be concealed from view above hung ceilings or recessed (flush) in walls and floors. Outlet boxes may only be exposed to view or surface mount type in mechanical and electrical rooms, or for feeding items overhead in rooms without ceilings.



**GLASTONBURY FIRE HOUSE  
BOILER REPLACEMENT  
GLASTONBURY, CONNECTICUT**

- C. Install outlet boxes at uniform heights and straight and true with reference to walls, floors, ceilings and casework.
- D. Provide knockout plugs in boxes with unused openings.
- E. Secure all outlet boxes to building structure with metal straps, rods, or bolts independently of entering conduits or cables.
- F. Provide bar hanger outlets in hollow framed partitions with bar hanger secured to partition studs with self-threading screws, or drill through hangers with Caddy or equal clips.
- G. Provide horizontal separation for outlet boxes mounted on opposite sides of common wall. Back to back or thru-wall boxes will not be permitted.

3.6 PULL BOXES AND JUNCTION BOXES:

- A. Provide pull boxes and junction boxes where shown on the plans and where required to facilitate proper pulling of wires and cables. Install pull boxes or pull fittings no less than one every 100 ft. of straight horizontal conduit run, or three 90 degree bends, unless otherwise noted.

3.7 WIRING DEVICES:

- A. Wherever possible install switches directly adjacent to the strike side of door. Check architectural drawings for door swing.
- B. Device mounting heights indicated below are general. Refer to drawings for special cases. Mounting heights are to centerline of device whether shown on plans or indicated below.

Receptacles	1'-6" AFF
Switches	4'-0" AFF

- C. Where receptacles and outlets are shown over counters, refer to architectural drawings for mounting heights.
- D. Install receptacles vertically with grounding posts at top of device, except locate grounding post to left for horizontal mounting.

3.8 WIRING DEVICE PLATES:

- A. Set plates so that all edges are in contact with mounting surface. Provide common device plate for multi-device locations.
- B. Provide electric outlet and switch sealers for all receptacles, switches and technology outlets installed at exterior walls.
- C. Align all wall plate screws with screw slots aligned in the vertical position.

3.9 MOTOR POWER AND CONTROL WIRING:

**GLASTONBURY FIRE HOUSE  
BOILER REPLACEMENT  
GLASTONBURY, CONNECTICUT**

- A. Contractor shall provide and be responsible for the complete power wiring of all motors and motorized equipment.
- B. Furnish proper overload and short circuit protection for all new motors. Provide a combination thermal overload and disconnect for switch all equipment using fractional horsepower motors.
- C. Check electrical connections and sizing of motor circuit protection and prevent damage to motor and equipment from incorrect direction of rotation.
- D. Provide mounting for motor and equipment disconnect switches adjacent to motor and supported independent of motor.
- E. Connections to miscellaneous building equipment:
  - 1. Wire to and connect to, all items of building equipment not specifically described in this Section but to which electrical power is required.
  - 2. Coordinate as necessary with other trades and suppliers to verify types, numbers and locations of equipment.

**3.10 GROUNDING SYSTEM:**

- A. Provide a complete grounding system which will thoroughly ground the non-current carrying metal parts of every piece of installed equipment, as described herein and as indicated on the drawings.
- B. System shall be mechanically and electrically connected to provide an independent return path to the grounding sources.
- C. Each grounding conductor shall have a minimum capacity of 25 percent of the rated capacity of the equipment it grounds, unless otherwise indicated.
- D. The minimum size of grounding conductors shall be No. 12 AWG copper. Insulation color of grounding conductors shall be green.
- E. Provide a separate green ground conductor for each branch circuit.

**3.11 SPECIAL REQUIREMENTS:**

- A. Wiring shall be bundle tied where passing through pull boxes, wireways, and panelboards in neat and orderly manner with plastic cable ties. Cable ties shall be Ty-Raps as manufactured by Thomas & Betts, or equal.
- B. Provide miscellaneous hardware and support accessories, including support rods, nuts, bolts, screws, and other such items, with galvanized or cadmium plated finish, or other approved rust inhibiting coatings.
- C. Unload electrical equipment and materials delivered to site. Pay cost for rigging, hoisting, lowering and moving electrical equipment on site, in building or on roof. During construction provide additional protection against moisture, dust accumulation and physical damage of

**GLASTONBURY FIRE HOUSE  
BOILER REPLACEMENT  
GLASTONBURY, CONNECTICUT**

electrical equipment. Provide temporary heaters within units, as approved to evaporate excessive moisture and provide ventilation as required.

3.12 TESTING AND INSPECTION:

- A. Provide personnel and equipment, make required tests, and secure required approvals from the Architect and governmental agencies having jurisdiction.
- B. When material and/or workmanship is found to not comply with the specified requirements, within three days after receipt of notice of such non-compliance remove the non-complying items from the job site and replace them with items complying with the specified requirements, all at no additional cost to the Owner.
- C. Perform all required adjustments and settings. Verify and correct deficiencies as necessary including voltages, tap settings, trip settings and phasing of equipment from distribution system to point of use.
- D. Provide all necessary testing equipment.
- E. In the Owner's Presence:
  - 1. Test all parts of the electrical system and prove that all such items provided under this Section function electrically in the required manner.

3.13 PROJECT COMPLETION:

- A. Upon completion of the work of this Section, thoroughly clean all exposed portions of the electrical installation, removing all traces of soil, labels, grease, oil and other foreign material, and using only the type cleaner recommended by the manufacturer of the item being cleaned.
- B. Equipment with damage to painted finish shall be repaired to satisfaction of the Architect.
- C. On the first day the facility is in operation, for at least eight hours, at a time directed by the Architect, provide a qualified foreman and crew to perform such electrical work as may be required by the Architect.
- E. Thoroughly indoctrinate the Owner's operation and maintenance personnel in the contents of the operations and maintenance manual required to be submitted under these Specifications.

3.14 EQUIPMENT SPECIFIED:

- A. Contractor shall furnish equipment or systems in manufacturers specified or named herein or on the drawings. No other manufacturers shall be considered.

END OF SECTION 16060

# GLASTONBURY FIRE HOUSE #1

## Boiler Replacement Glastonbury, Connecticut

**BEMIS ASSOCIATES, L.L.C.**  
Consulting Engineers

101 Fenn Road  
Newington, Ct 06111  
832-429-6992  
Fax: (860) 667-3579  
www.bemisassociates.com



PROJECT #  
GL-2010-42C01

TITLE  
FIRST FLOOR  
ELECTRICAL PLAN

DATE 4/6/10

DWG. NO.  
**E-1**

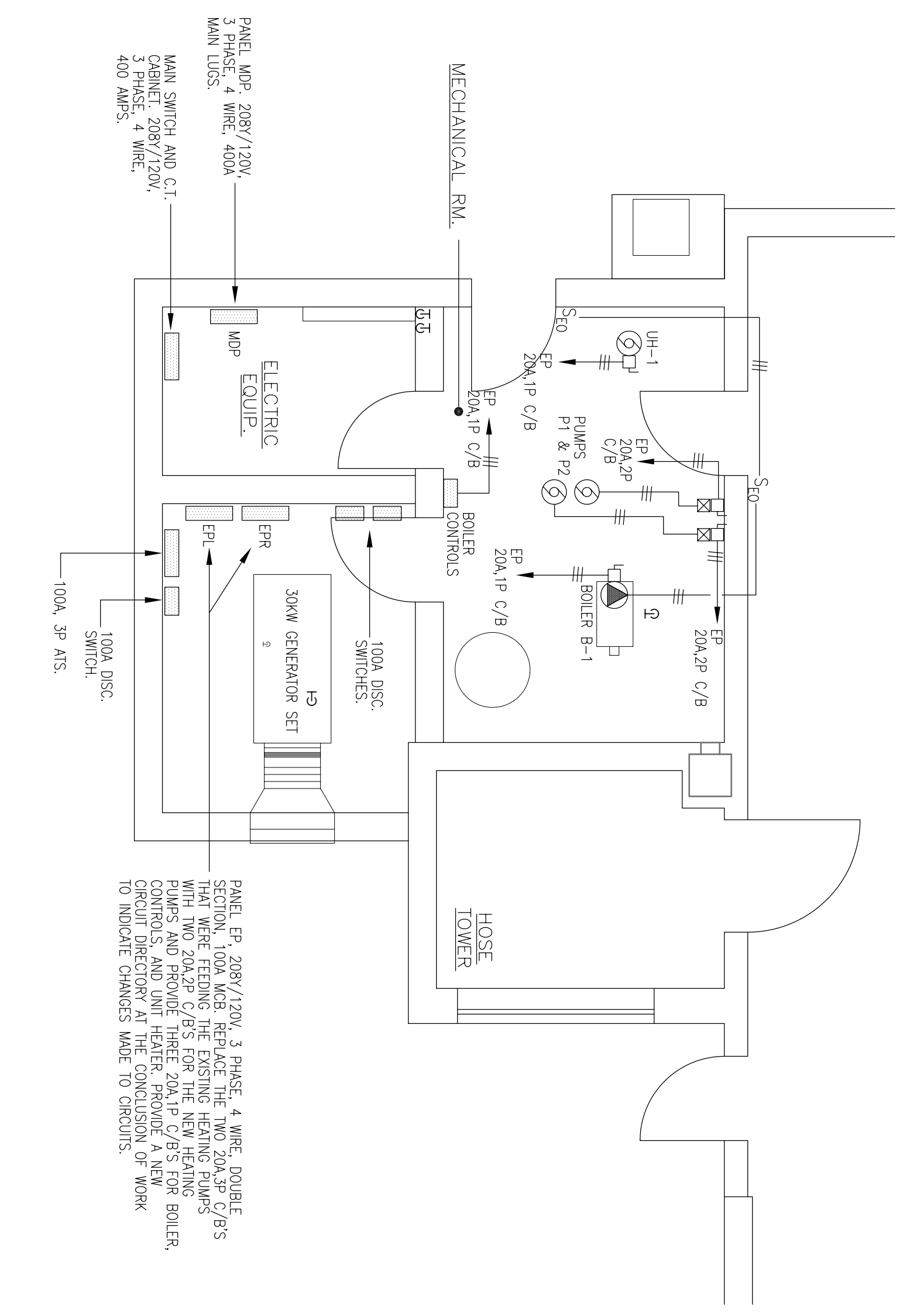

**BOILER ROOM PART PLAN - ELECTRICAL NEW WORK**  
SCALE: 1/4"=1'-0"

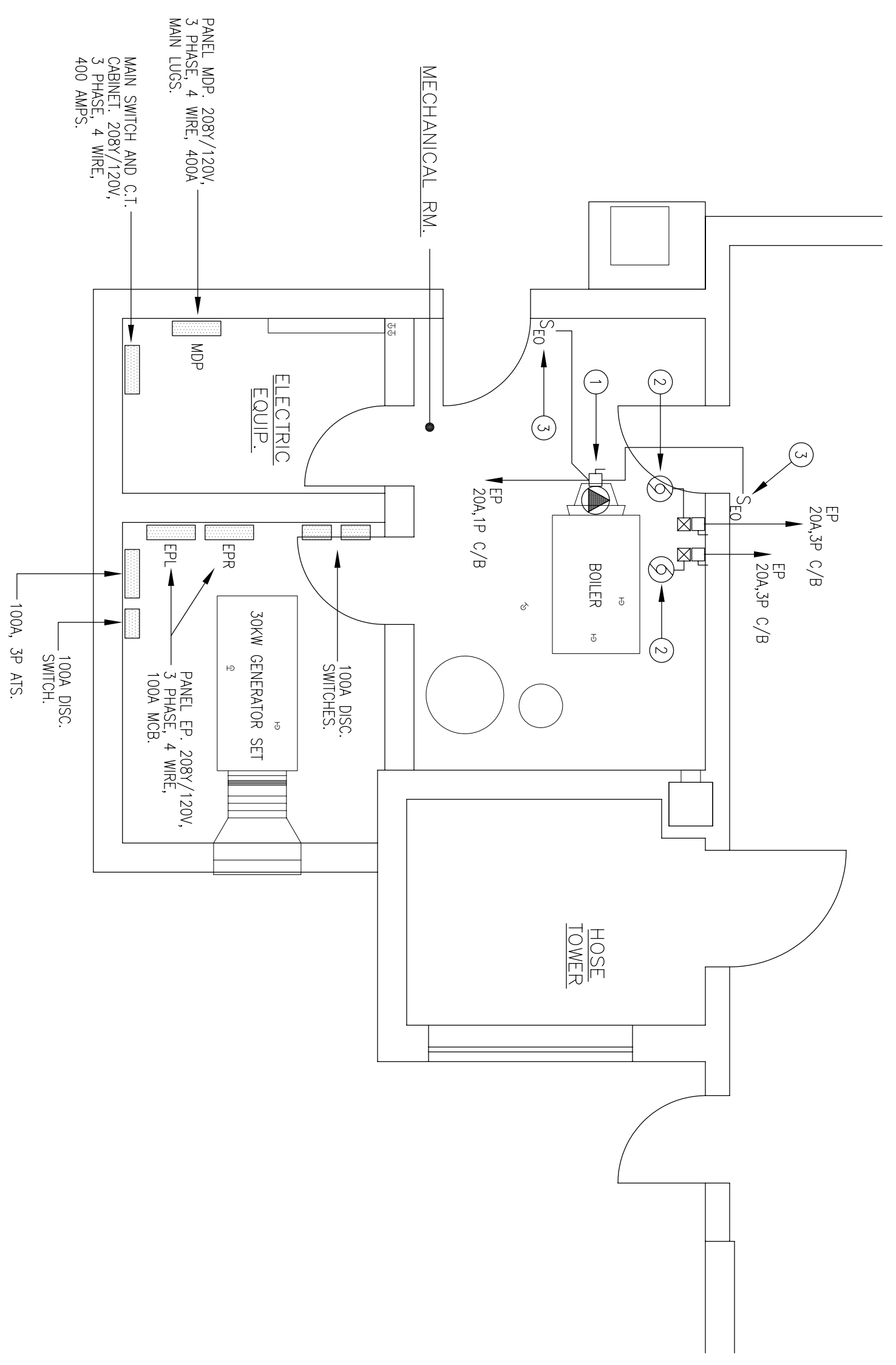

**BOILER ROOM PART PLAN - ELECTRICAL DEMOLITION**  
SCALE: 1/4"=1'-0"

- DRAWING LEGEND**
- SPECIAL EQUIPMENT POWER CONNECTION, EQUIPMENT TYPE AS DESIGNATED.
  - MOTOR POWER CONNECTION, EQUIPMENT TYPE AS DESIGNATED.
  - PANELBOARD
  - DISCONNECT SWITCH
  - MOTOR STARTER
  - EMERGENCY BOILER OFF SWITCH, 60" AFT
  - BRANCH CIRCUIT HOMERUN IN EMT CONDUIT, CROSS LINES INDICATE NUMBER OF CONDUCTORS.
  - BRANCH CIRCUIT HOMERUN IN EMT CONDUIT, CROSS LINES INDICATE NUMBER OF CONDUCTORS.
  - ABOVE FINISHED FLOOR
  - AUTOMATIC TRANSFER SWITCH
  - CONDUIT (EM).
  - CIRCUIT BREAKER
  - POLE
  - UNIT HEATER.

- ELECTRICAL DEMOLITION WORK SYMBOLS -

TAG	ACTION
①	DISCONNECT AND REMOVE EXISTING BURNER BRANCH CIRCUIT AND ALL WIRING ASSOCIATED WITH THE BOILER.
②	DISCONNECT AND REMOVE EXISTING HEATING PUMP BRANCH CIRCUIT, STARTER, AND DISCONNECTS.
③	DISCONNECT AND REMOVE EXISTING BOILER EMERGENCY OFF SWITCHES AND ASSOCIATED WIRING.

- ELECTRICAL DEMOLITION WORK NOTES**
- 1 - PRIOR TO STARTING BID, VISIT THE SITE AND DETERMINE EXISTING CONDITIONS AND DEFICIENCIES THAT WILL AFFECT WORK TO BE PERFORMED. NO COMPENSATION WILL BE GRANTED FOR ADDITIONAL WORK CAUSED BY UNFAMILIARITY WITH SITE CONDITIONS THAT ARE VISIBLE OR RECALLY CONSTRUED BY EXPERIENCED OBSERVERS. INCLUDE IN THE BID ALL DEMOLITION WORK REQUIRED.
  - 2 - THE DEMOLITION DRAWINGS ARE INTENDED ONLY TO DEFINE THE GENERAL SCOPE OF DEMOLITION WORK AND TO ASSIST THE CONTRACTOR DURING BIDDING. THE DEMOLITION DRAWINGS MAY NOT SHOW EVERY ITEM WHICH MUST BE DISCONNECTED, REMOVED, OR RELOCATED IN ORDER TO FACILITATE NEW WORK. THE CONTRACTOR SHALL BE RESPONSIBLE FOR ALL DEMOLITION WORK REQUIRED WHETHER OR NOT SHOWN ON THE PLANS.
  - 3 - REMOVE AND/OR RELOCATE ALL EXISTING ELECTRICAL WORK AS NECESSARY FOR THE PERFORMANCE OF THE WORK OF THIS CONTRACT.
  - 4 - EXISTING ELECTRICAL EQUIPMENT, WIRING, AND RACEWAYS SHALL NOT BE REUSED UNLESS SPECIFICALLY NOTED OTHERWISE.
  - 5 - REMOVE ALL DEMOLITION MATERIAL FROM THE JOB SITE UNLESS NOTED DIFFERENTLY. MATERIAL REQUESTED BY THE OWNER FOR SQUARE SHALL BE DELIVERED TO THE OWNER'S DESIGNATED MATERIAL STORAGE AREA.

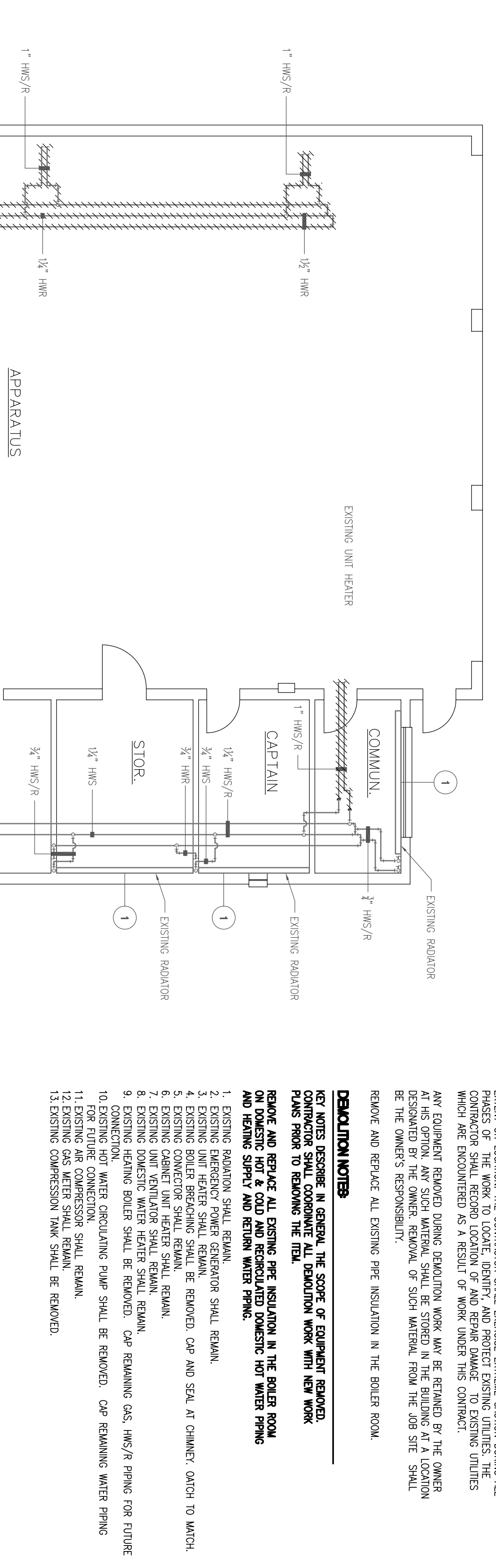

- GENERAL DEMOLITION NOTES:**
- THE CONTRACTOR SHALL BE RESPONSIBLE FOR THE LOCATION AND PROTECTION OF ALL EXISTING UTILITIES. THE CONTRACTOR SHALL VERIFY THE LOCATION AND DEPTH OF ALL UTILITIES. THE CONTRACTOR SHALL BE RESPONSIBLE FOR THE PROTECTION OF ALL UTILITIES. THE CONTRACTOR SHALL BE RESPONSIBLE FOR THE PROTECTION OF ALL UTILITIES. THE CONTRACTOR SHALL BE RESPONSIBLE FOR THE PROTECTION OF ALL UTILITIES.
- DEMOLITION NOTES:**
1. EXISTING RADIATOR SHALL REMAIN.
  2. EXISTING EMERGENCY POWER GENERATOR SHALL REMAIN.
  3. EXISTING UNIT HEATER SHALL REMAIN.
  4. EXISTING UNIT HEATER SHALL REMAIN.
  5. EXISTING CONNECTOR SHALL REMAIN.
  6. EXISTING UNIT HEATER SHALL REMAIN.
  7. EXISTING UNIT HEATER SHALL REMAIN.
  8. EXISTING UNIT HEATER SHALL REMAIN.
  9. EXISTING HEATING BOILER SHALL BE REMOVED. CAP REMAINING GAS, WMS/R PIPING FOR FUTURE CONNECTION.
  10. EXISTING HOT WATER CIRCULATING PUMP SHALL BE REMOVED. CAP REMAINING WATER PUMP.
  11. EXISTING AIR COMPRESSOR SHALL REMAIN.
  12. EXISTING GAS METER SHALL REMAIN.
  13. EXISTING COMPRESSION TANK SHALL BE REMOVED.

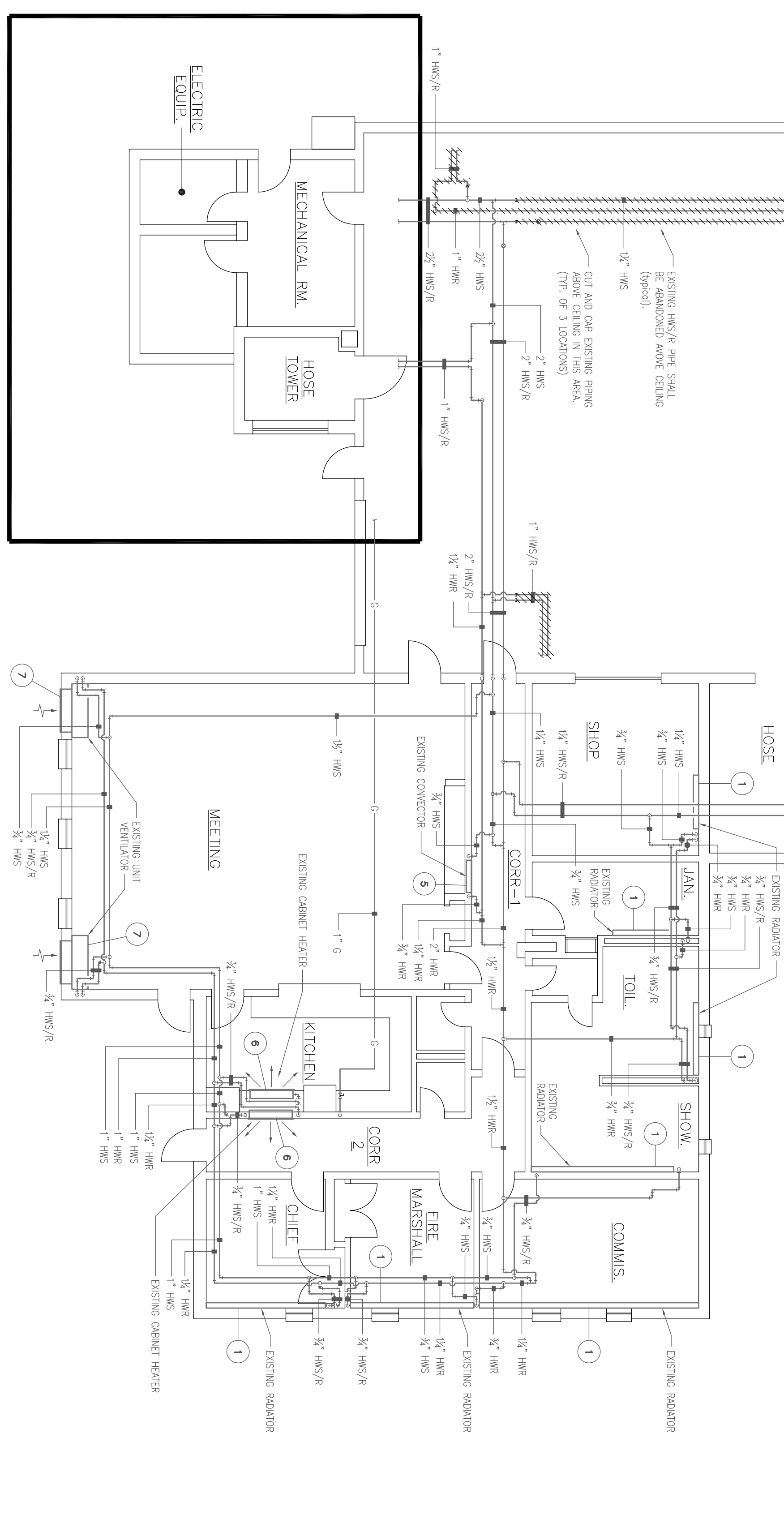

**FIRST FLOOR DEMOLITION PLAN - MECHANICAL**  
SCALE: 1/8"=1'-0"

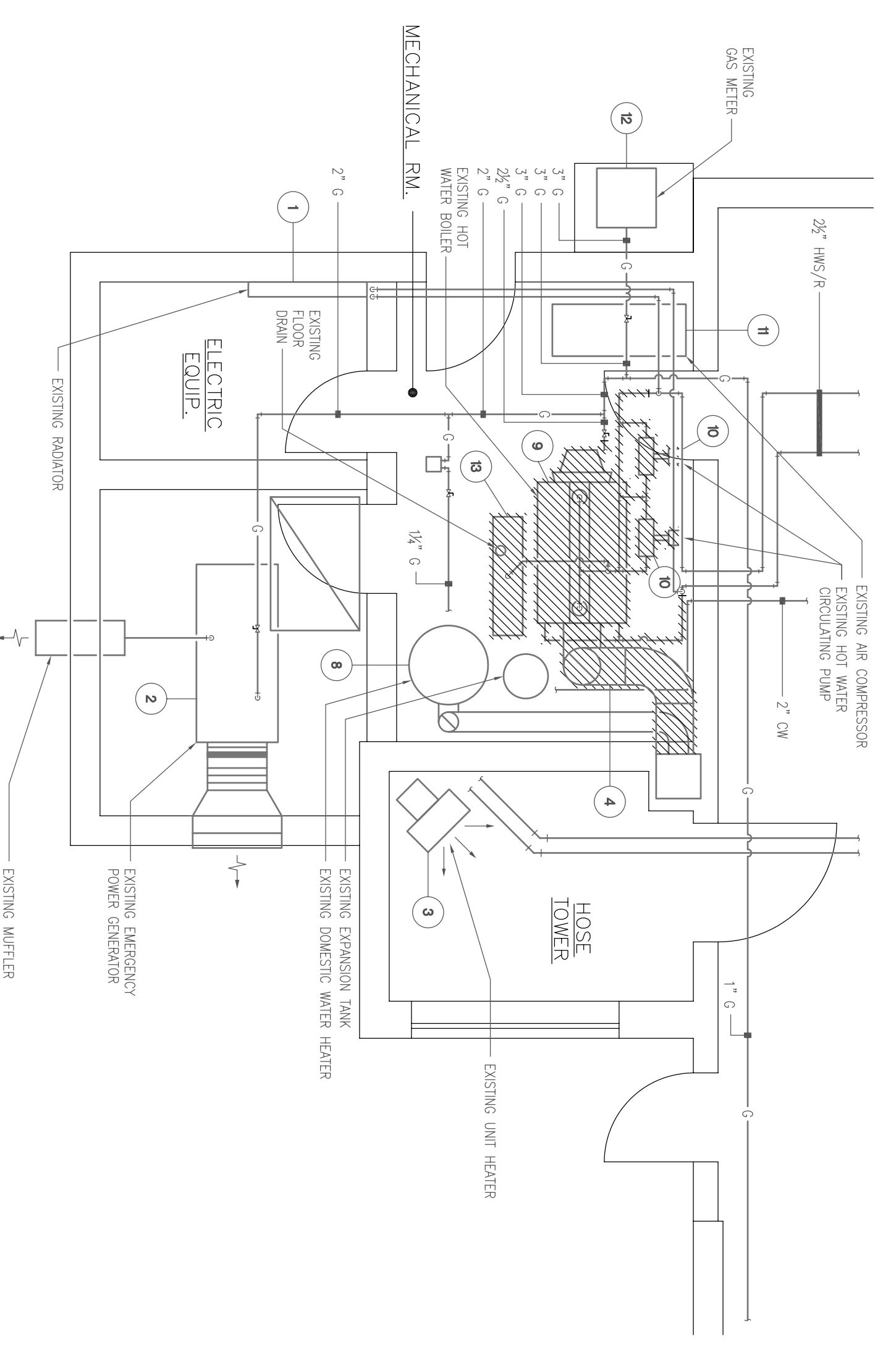

**BOILER ROOM DEMOLITION PART PLAN - MECHANICAL**  
SCALE: 1/4"=1'-0"

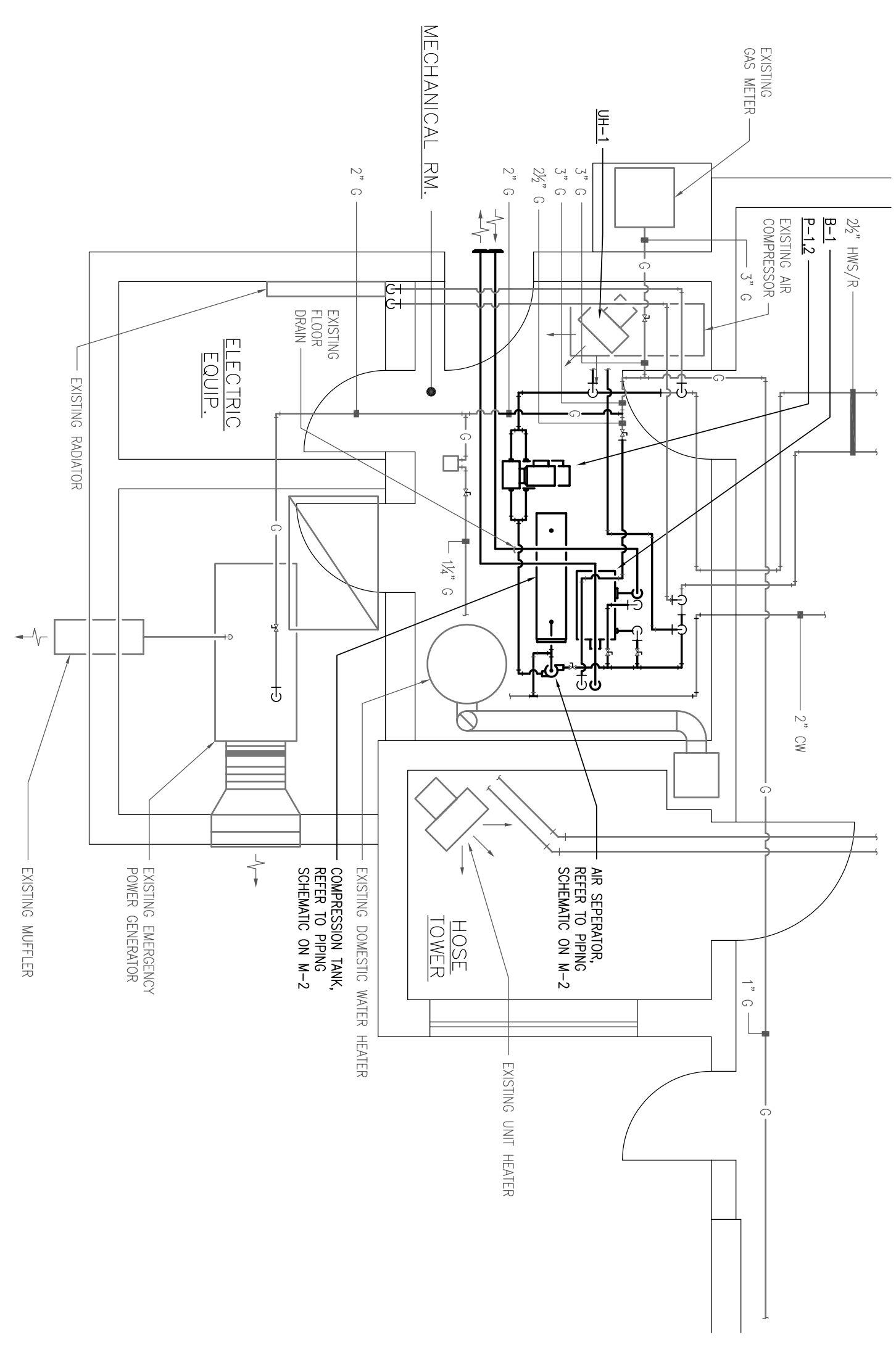

**BOILER ROOM PART PLAN - MECHANICAL**  
SCALE: 1/4"=1'-0"

AREA SERVED	TAG	LOCATION	MANUF.	SERIES	MODEL	MODULES	INPUT (MBH)	OUTPUT (MBH)	NET HEAT (BTU)	VENT DM. EFFICIENCY	THERMAL HEATER	WATER GAS HEATER	FUEL	REMARKS		
B-1		MECHANICAL RM.	LOCHINVAR	KNIGHT XL	KB9399	1	80	399	372	324	4"	4"	93.3%	1/2"	1"	1.2,3,4,5,6,7,8

- REMARKS:**
- REFER TO SPECIFICATIONS FOR ADDITIONAL INFORMATION.
  - POWER WIRING AND RACING BY DIVISION 16.
  - DISCONNECT MOTOR STARTERS AND CONTROLS BY DIVISION 15.
  - BOILER MANUFACTURER SHALL PROVIDE HI/LOW GAS PRESSURE RESET AND TEST CONDENSATE NEUTRALIZATION KIT, SIZE SHALL BE AS SPECIFIED BY MANUFACTURER'S RECOMMENDATION.
  - CONTROLS BY BOILER MANUFACTURER. INTERFACE WITH NEW DDC CONTROLS TO CONTROL NEW CIRCULATING PUMPS.
  - BOILER MANUFACTURER SHALL SELECT AND PROVIDE BOILER.
  - CIRCULATING PUMP BASED ON 3% TEMPERATURE RISE. BOILER MANUFACTURER SHALL PROVIDE 9" CONCRETE PAD.
  - CONTRACTOR SHALL PROVIDE 9" CONCRETE PAD.
  - INSTALL BOILER PER MANUFACTURER'S RECOMMENDATION.

PUMP No.	LOCATION	AREA SERVED	TYPE	MANUFACTURER	SERIES	MODEL	GPM	HEAD (FT)	HP	PH	POWER (KW)	VOLTS	PH	EFFICIENCY	STATION DRESSER	Triple Duty Value	REMARKS
P-1	MECHANICAL RM.	FIRE HOUSE #1	N/LINE	GRUNDOS	WASH	40-120 F	25	20	-	25-450	230	1	-	-	-	-	1.2
P-2	MECHANICAL RM.	FIRE HOUSE #1	N/LINE	GRUNDOS	WASH	40-120 F	25	20	-	25-450	230	1	-	-	-	-	1.3

- REMARKS:**
- UNIT SHALL BE SEISMICALLY SUPPORTED. INSTALLATION SHALL BE IN ACCORDANCE WITH MANUFACTURER'S RECOMMENDATIONS.
  - OPERATING.
  - SHALL BE 4" PUMP MOTOR SHALL BE PREMIUM EFFICIENCY.

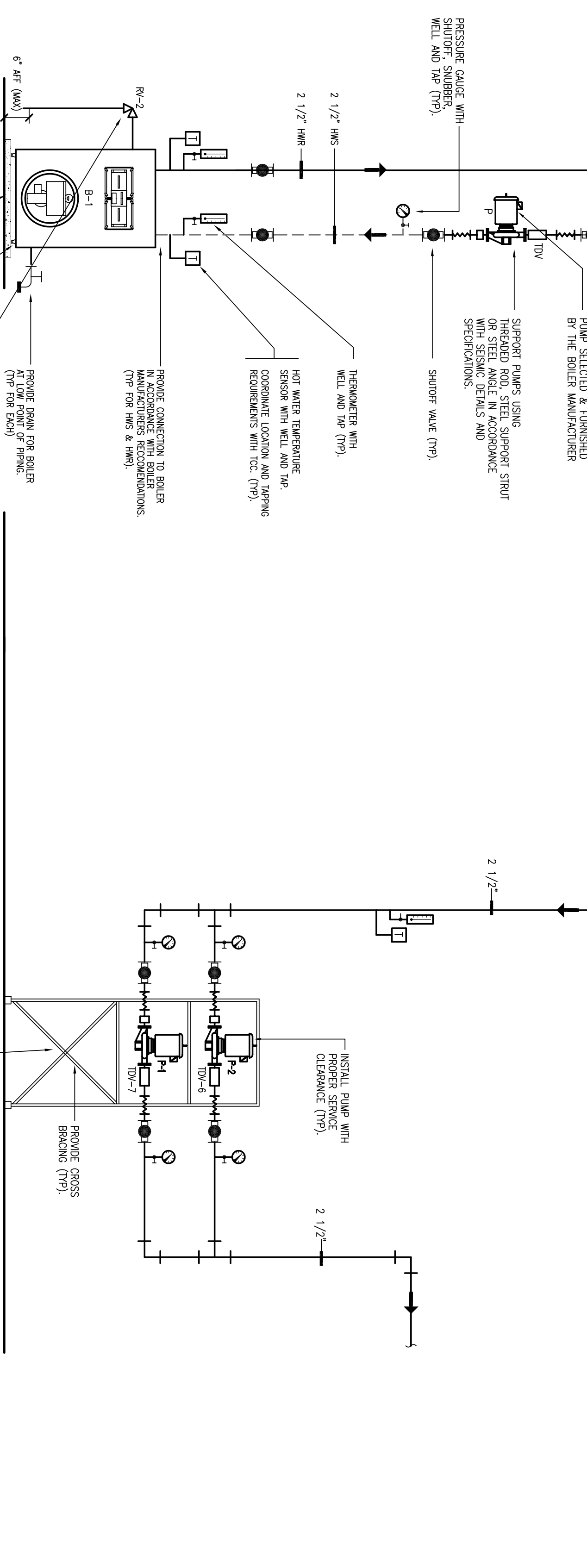
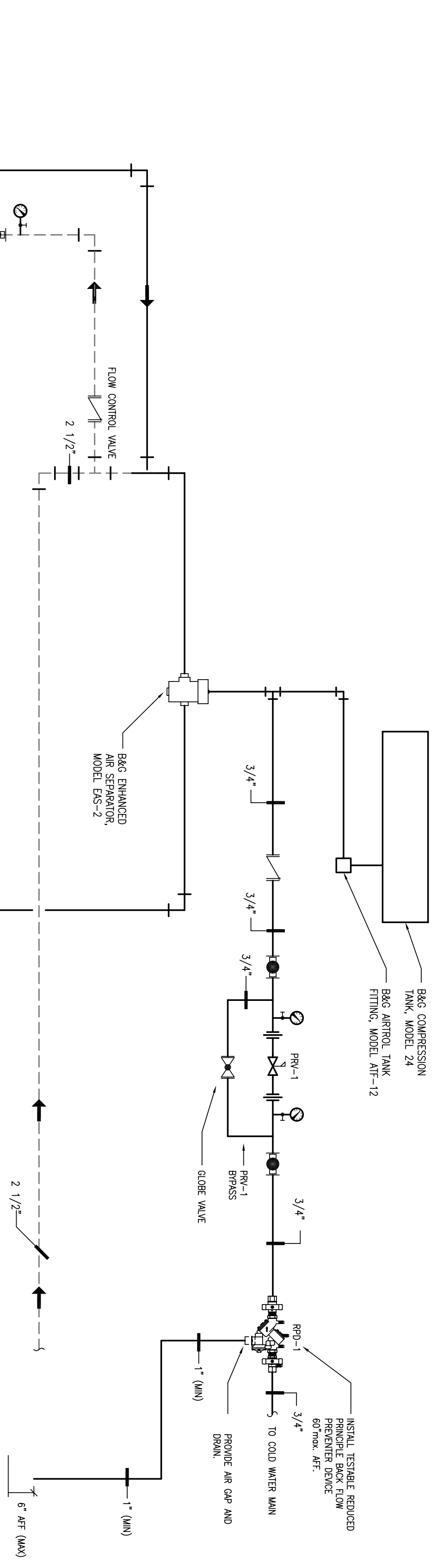

**BOILER ROOM PIPING SCHEMATIC**  
NO SCALE

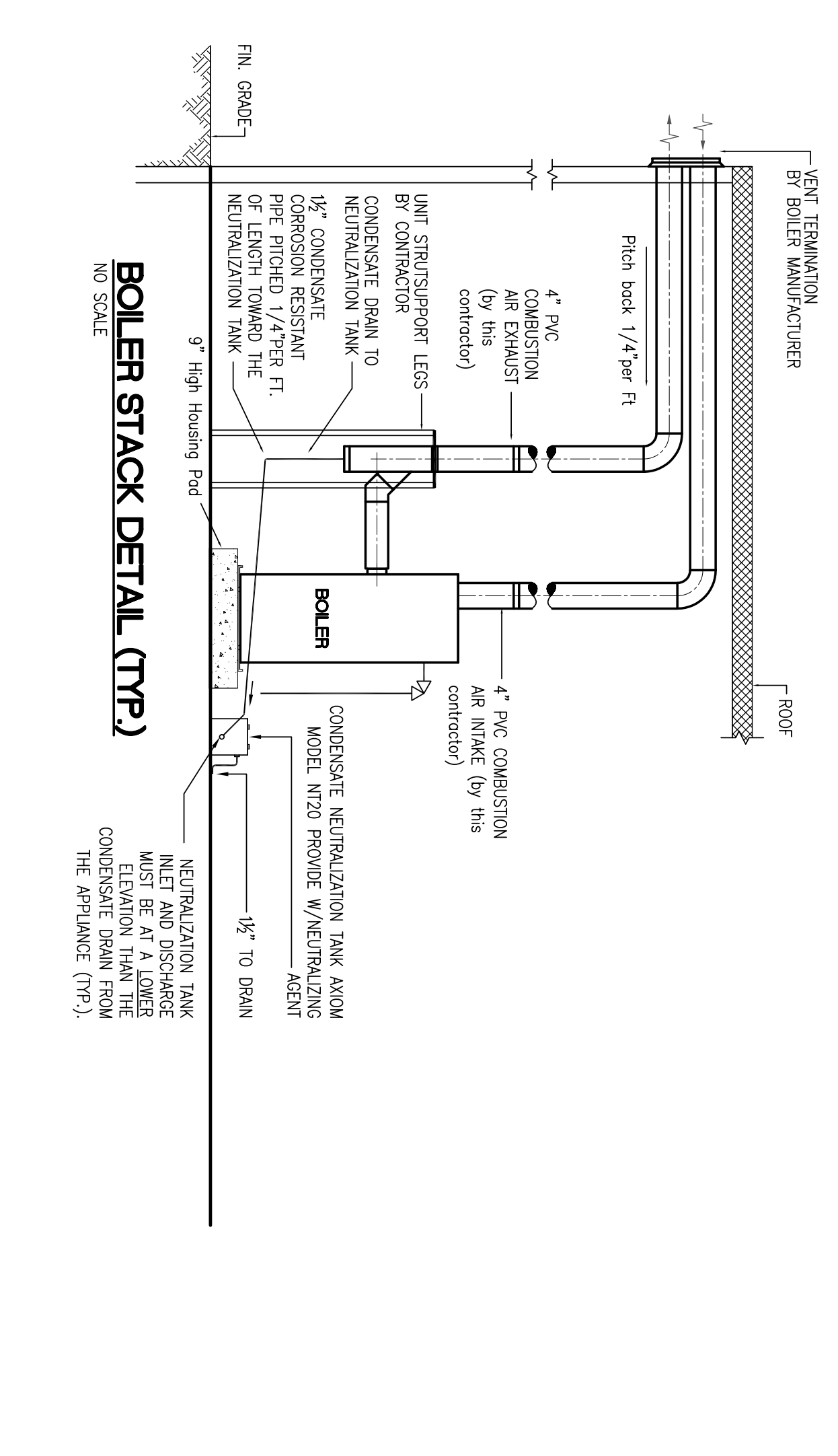

**BOILER STACK DETAIL (TYP)**  
NO SCALE

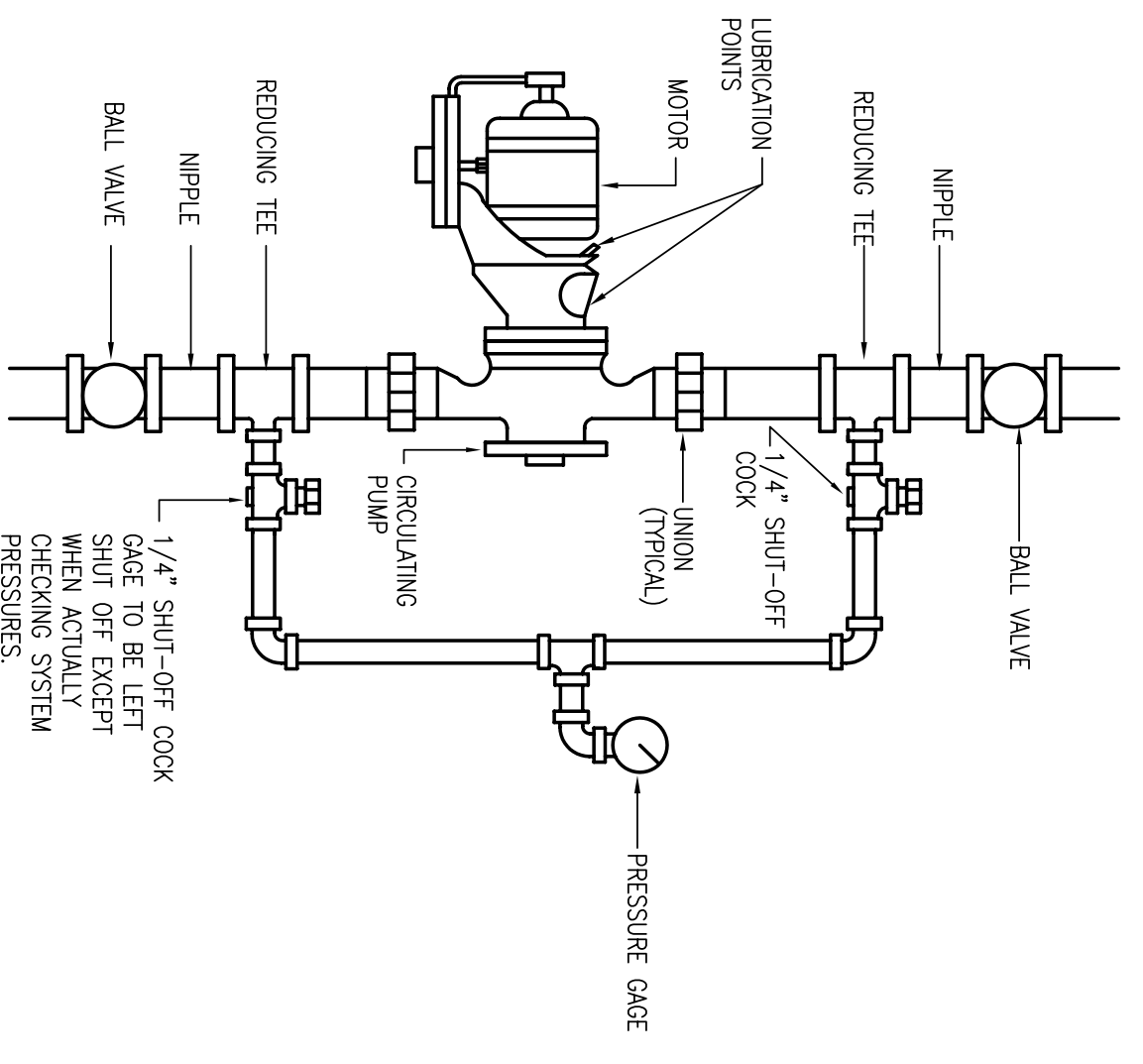

**INSTALLATION DETAILS OF IN-LINE CIRCULATING PUMP**  
NO SCALE

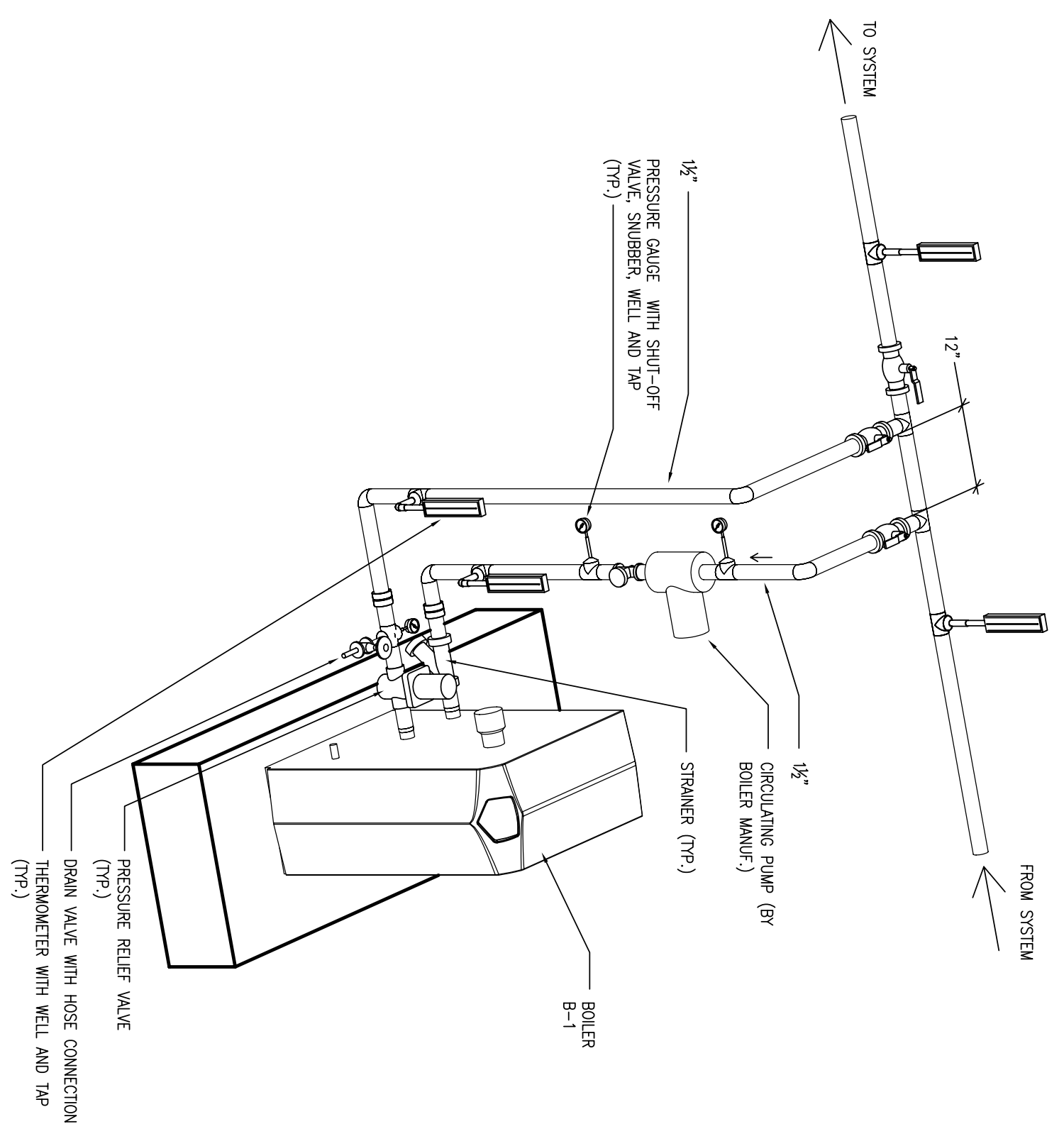

**BOILER PIPING DETAIL**  
NO SCALE

UNIT NO.	AREA SERVED	MANUF.	MODEL	CUA	LBH	GAH	ENT	WD	HP	LAT	HP	PH	PH	VOLTS	REMARKS		
UH-1	MECHANICAL RM.	VILCOX	HH-108A	210	6.8	0.8	200	20	0.8	60	91	9	WAT	1350	1	115	1.2

- REMARKS:**
- UNIT SHALL BE SEISMICALLY SUPPORTED.
  - UNIT SHALL BE SEISMICALLY SUPPORTED.

**SEQUENCE OF OPERATIONS**

- BOILER**
- THE BOILER WILL BE ENABLED TO RUN WHEN EITHER THE OUTSIDE AIR TEMPERATURE IS ABOVE 40 DEGREES F (ADJUSTABLE) OR THE OUTSIDE AIR TEMPERATURE DROPS TO 60 DEGREES F (ADJUSTABLE). IF THE LEAD PUMP SHOULD FAIL, AS DETERMINED BY A CURRENT SWITCH, THE LAG PUMP SHALL START AND AN ALARM INDICATED AT THE LEAD END. TO ENJOY WEAR BETWEEN THE PUMPS.
  - THE HOT WATER SUPPLY TEMPERATURE SHALL BE RESET BY OUTSIDE AIR TEMPERATURE ON A SCHEDULE AS DETERMINED BY THE ENGINEER BY MODULATING THE BOILER BURNERS.
- UNIT HEADERS**
- A LINE VOLTAGE SENSITIVELY SHALL MAINTAIN ITS SETPOINT BY CYCLING THE UNIT HEADERS.
  - A LINE VOLTAGE SENSITIVELY SHALL MAINTAIN ITS SETPOINT BY CYCLING THE UNIT HEADERS.

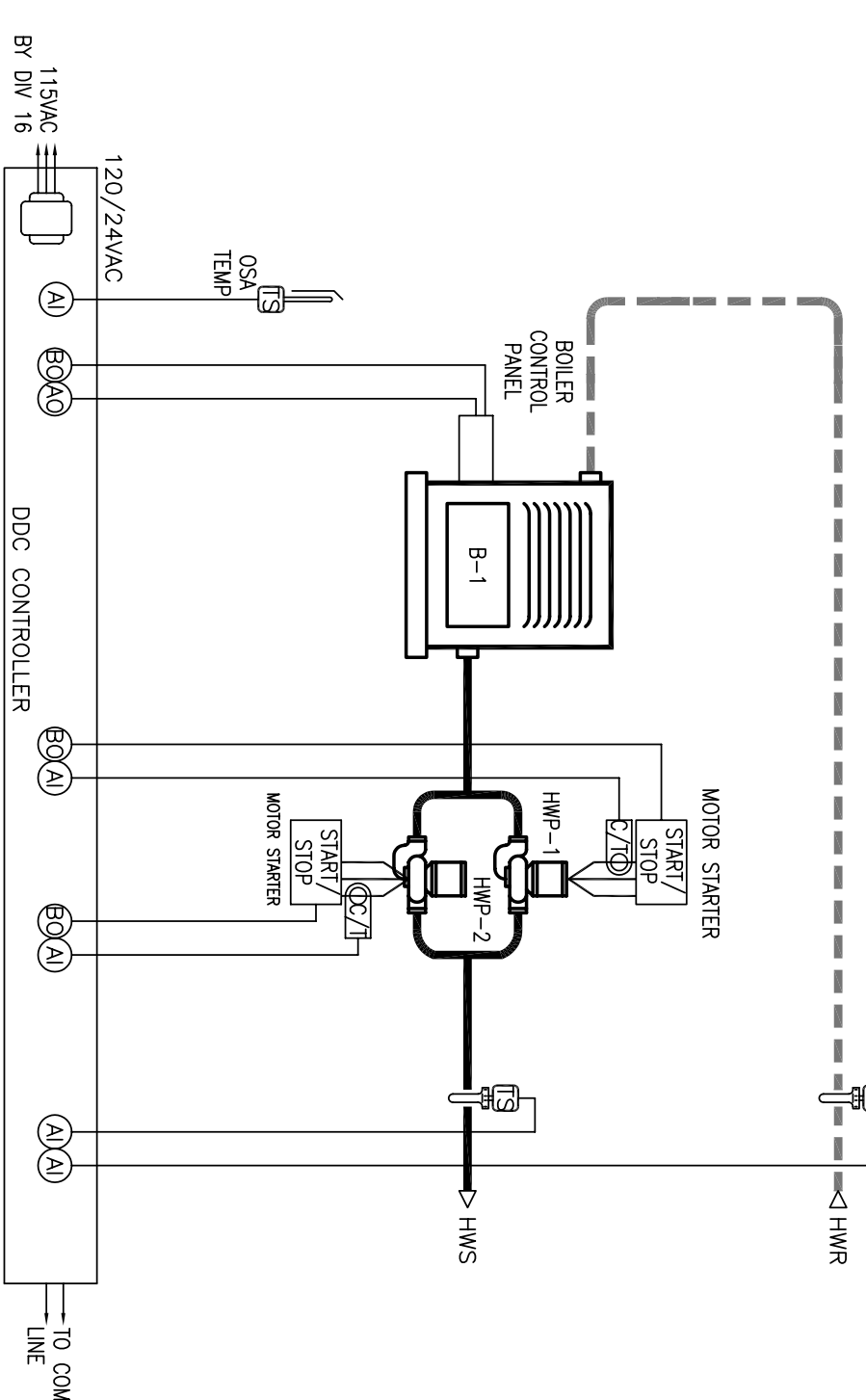

**BOILER CONTROLS DIAGRAM**  
NO SCALE

TITLE  
MECHANICAL  
SCHEDULES,  
DETAILS AND  
PIPING DIAGRAMS

PROJECT #  
GL-2010-42C01

DATE  
4/6/10

DWG. NO.  
M-2

**BEMIS ASSOCIATES, L.L.C.**  
Consulting Engineers

101 Fenn Road  
Newington, Ct 06111  
832-524-230 (999)  
Fax: (860) 667-3579  
www.bemisassociates.com

**GLASTONBURY FIRE HOUSE #1**

Boiler Replacement  
Glastonbury, Connecticut