

TOWN OF GLASTONBURY
ENGINEERING DIVISION
PW-E20 ANNUAL PAVING PROGRAM

CONTRACT DOCUMENTS

FOR

STORM DRAINAGE AND CATCH BASIN REHABILITATION
LOCATED ON VARIOUS TOWN ROADS
GL-2023-35

PROJECT STREETS:

CAVAN LANE, CRESTDALE ROAD, FAIRVIEW TERRACE, GLENWOOD ROAD, GRINDLE BROOK ROAD, ORCHARD STREET (HEBRON AVENUE TO CHASE HOLLOW LANE), STRICKLAND STREET (TREAT ROAD TO SAND HILL LANE), TARA DRIVE



ADVERTISED ON: MAY 10, 2023

BID DUE DATE: MAY 31, 2023

TOWN OF GLASTONBURY

INVITATION TO BID

<u>BID #</u>	<u>ITEM</u>	<u>DATE & TIME REQUIRED</u>
GL-2023-35	Storm Drainage and Catch Basin Rehabilitation	May 31, 2023 at 11:00 A.M.

The Town of Glastonbury will receive on-line bids to perform storm drainage and catch basin rehabilitation located on various town roads including Cavan Lane, Crestdale Road, Fairview Terrace, Glenwood Road, Grindle Brook Road, Orchard Street (Hebron Avenue to Chase Hollow Lane), Strickland Street (Treat Road to Sand Hill Lane), and Tara Drive in Glastonbury.

Bidders wishing to submit a bid proposal for this solicitation are directed to respond online through a secure e-Procurement portal. Responses can be submitted at the following link: <https://app.negometrix.com/buyer/2832>, under the bid title "**GL-2023-35 - Storm Drainage and Catch Basin Rehabilitation**". All bids will be publicly opened and read aloud. **No late bids will be accepted.**

This Invitation to Bid, Instructions to Bidders, Drawings, Specifications and other Bidding Documents (as defined in the Instruction to Bidders) are available for viewing and downloading on the Town of Glastonbury website www.glastonburyct.gov or the State's website at www.das.state.ct.us at no cost.

Each Bid must be accompanied by a bid security in the form of a Bid Bond, certified in an amount not less than 10% of the base bid except as otherwise expressly provided in the Instruction to Bidders. The successful bidder will be required to provide performance and labor and material payment bonds in the full amount of the agreed contract price.

Bidders are further advised that this project is subject to the prevailing wage requirements of Connecticut General Statutes Section 31-53.

Bidders are also hereby alerted to the schedule requirements as outlined in Special Conditions Section 11.00.

The Town of Glastonbury is An Affirmative Action/Equal Opportunity Employer. Minority/Women's Business Enterprises are encouraged to bid.

The Town reserves the right to amend or withdraw this Invitation to Bid for any reason, to accept or reject any or all Bids, to waive any informalities or non-material deficiencies in any Bid, and to make such award (or make no award) of a contract in connection with this Invitation to Bid all as determined by the Town, in its discretion, to be in the best interest of the Town. A Bid may be rejected for irregularities of any kind, including without limitation, alteration of form, additions not called for, conditional proposals, and incomplete Bids. A Bid may also be rejected if, in the opinion of the Town, the Bid does not meet the standard of quality established by the Bidding Documents. Any or all Bids may be rejected if there is any reason to believe that collusion exists among two or more Bidders. The foregoing provisions are for illustrative purposes and shall in no way limit the right of the Town to reject any and all Bids, in whole or in part.

Gina Consiglio
Purchasing Agent

**STORM DRAINAGE AND CATCH BASIN REHABILITATION
LOCATED ON VARIOUS TOWN ROADS
INFORMATION FOR BIDDERS**

BID #GL-2023-35

TABLE OF CONTENTS

SECTION

[INFORMATION FOR BIDDERS](#)

IB

[GENERAL CONSTRUCTION SPECIFICATIONS](#)

GCS

[SPECIAL CONDITIONS](#)

SC

[BID PROPOSAL](#)

BP

[SPECIAL PROVISIONS](#)

SP

[ATTACHMENT A: PREVAILING WAGE RATES](#)

**STORM DRAINAGE AND CATCH BASIN REHABILITATION
LOCATED ON VARIOUS TOWN ROADS
INFORMATION FOR BIDDERS**

BID #GL-2023-35

1. Bidders submitting a response for this solicitation are directed to respond online through a secure e-Procurement portal. Bids can be submitted at the following link: <https://app.negometrix.com/buyer/2832> under the bid title "**GL-2023-35 - Storm Drainage and Catch Basin Rehabilitation**". Bidders will be required to create a profile before submitting their bid. Step-by-step instructions on how to register as a vendor are available at this website:

<https://help.negometrix.com/en/support/solutions/articles/9000177626-register-on-negometrix4>

Bidders will be required to upload their bid response in **one consolidated pdf document** in the following file located in the bid portal:

- Bid Response & Related Documents
2. Whenever it is deemed to be in the best interest of the Town, the Town Manager, Purchasing Agent or designated representative shall waive informalities in any and all bids. The right is reserved to reject any bid when such action is deemed to be in the best interest of the Town of Glastonbury.
 3. The award will be on the basis of bid total cost of the lowest qualified, responsible, and responsive bidder, including any bid alternates selected by the Town, unless otherwise specified. The bid total cost shall be arrived at by the mathematical calculation of the unit price multiplied times the number of units specified for each line item, and the total sum of all line items in the bid. In the event that the Town finds computational errors in a respondent's bid proposal, the bid total cost shall be recalculated by the Town based on the unit prices contained in the bid proposal.
 4. Bids will be carefully evaluated as to conformance with stated specifications.
 5. Specifications must be submitted complete in every detail and, when requested, samples shall be provided. If a bid involves any exception from stated specifications, they must be clearly noted as exceptions, underlined, and attached to the bid.
 6. The Bid Documents contain the provisions required for the requested item. Information obtained from an officer, agent, or employee of the Town or any other person shall not affect the risks or obligations assumed by the Bidder or relieve him/her from fulfilling any of the conditions of the bid.
 7. Each Bidder is held responsible for the examination and/or to have acquainted themselves with any conditions at the job site which would affect their work before submitting a bid. Failure to meet this criteria shall not relieve the Bidder of the responsibility of completing the bid without extra cost to the Town of Glastonbury.
 8. Any bid may be withdrawn prior to the above-scheduled time for the opening of bids or authorized postponement thereof. Any bid received after the time and date specified shall not be considered. No Bidder may withdraw a bid within sixty (60) days after the actual date of the opening thereof. Should there be reasons why a bid cannot be awarded within the specified period, the time may be extended by mutual agreement between the Town and the Bidder.
 9. Each electronic bid submission must be accompanied by a COPY of the bid bond payable to the Town for ten percent (10%) of the total amount of the bid. Original bid bonds from all respondents must be mailed to the attention of the Purchasing Agent immediately (within 24 hours) following the virtual bid opening at the following address: Town of Glastonbury, PO Box 6523, Glastonbury, CT 06033-6523, Attn: Gina Consiglio, Purchasing Agent. The bid bond of the successful Bidder will be retained until the payment bond and performance bond have been executed and approved, after which it will be returned.

**STORM DRAINAGE AND CATCH BASIN REHABILITATION
LOCATED ON VARIOUS TOWN ROADS
INFORMATION FOR BIDDERS**

BID #GL-2023-35

10. A 100% Performance and a 100% Payment bond are required of the successful bidder. This bond shall cover all aspects of the specification and shall be delivered to the Purchasing Agent prior to the issuance of a purchase order. The Performance and Payment Bond will be returned upon the delivery and acceptance of the bid items.
11. The Bidder agrees and warrants that in the submission of this sealed Bid, they will not discriminate or permit discrimination against any person or group of persons on the grounds of race, color, religion, national origin, sex, or physical disability including, but not limited to blindness, unless it is shown by such Bidder that such disability prevents performance of that which must be done to successfully fulfill the terms of this sealed Bid or in any manner which is prohibited by the laws of the United States or the State of Connecticut: and further agrees to provide the Connecticut Human Relations Commission with such information requested by the Commission concerning the employment practices and procedures of the Bidder. An Affirmative Action Statement will be required by the successful Bidder.
12. Bidder agrees to comply with all of the latest Federal and State Safety Standards and Regulations and certifies that all work required in this bid will conform to and comply with said standards and regulations. Bidder further agrees to indemnify and hold harmless the Town for all damages assessed against the Town as a result of Bidder's failure to comply with said standards and/or regulations.
13. All correspondence regarding any purchase made by the Town of Glastonbury shall reference the Town's purchase order number. Each shipping container shall clearly indicate both Town purchase order number and item number.
14. Bidder is required to review the Town of Glastonbury Code of Ethics adopted July 8, 2003 and effective August 1, 2003 and revised October 29, 2013 and effective November 28, 2013. Bidder shall acknowledge that they have reviewed the document in the area provided on the bid/proposal response page (BP-1). The selected Bidder will also be required to complete and sign an Acknowledgement Form prior to award. The Code of Ethics and the Acknowledgement Form can be accessed at the Town of Glastonbury website at www.glastonburyct.gov. Upon entering the website scroll down to click on Bids & Proposals Icon which will bring you to the links for the Code of Ethics and the Acknowledgement Form.
15. **Non-Resident Contractors:** (if applicable)
Upon award the Town is required to report names of nonresident (out of state) Contractors to the State of Connecticut, Department of Revenue Services (DRS) to ensure that Employment Taxes and other applicable taxes are being paid by Contractors. **A single surety bond for 5% of the entire contract price is required to be filed with DRS by any unverified nonresident prime or general contractor (if awarded) where the contract price for the project is \$250,000 or more.** The contractor will be required to promptly furnish to the Town a copy of the **Form AU-968 - Certificate of Compliance** issued by the State of Connecticut, DRS. See State of Connecticut **Notice SN 2012 (2).**
16. Bidder shall include on a sheet(s) attached to its proposal a complete disclosure of all past and pending mediation, arbitration and litigation cases that the bidder or its principals (regardless of their place of employment) have been involved in for the most recent five years. Please include a statement of the issues in dispute and their resolution. Acceptability of Bidder based upon this disclosure shall lie solely with the Town.
17. Bidder or its principals, regardless of their place of employment, shall not have been convicted of, nor entered any plea of guilty, or nolo contendere, or otherwise have been found civilly liable or criminally responsible for any criminal offense or civil action. Bidder shall not be in violation of any State or local ethics standards or other offenses arising out of the submission of bids or proposals, or performance of work on public works projects or contracts.

**STORM DRAINAGE AND CATCH BASIN REHABILITATION
LOCATED ON VARIOUS TOWN ROADS
INFORMATION FOR BIDDERS**

BID #GL-2023-35

18. **State Prevailing Wage Rates:**

Respondents shall comply with State Statutes concerning Employment and Labor Practices, if applicable, and Section 31-53 of the Connecticut General Statutes, as amended (Prevailing Wages). Wage Rate Determination for this project from the State of Connecticut is included in the Bid Documents. Certified payrolls for site labor shall be submitted weekly to the Town's Representative or his designee on the correct State of Connecticut form (see RFP). The Town reserves the right to, without prior notice, audit payroll checks given to workers on site in order to ascertain that wages and fringe benefits are being paid as required by the State of Connecticut. Please make special note of the State requirement to adjust wage and fringe benefit rates on each July 1st following the original published rates.

NOTE that respondent is to include in its proposal all costs required by such annual increases in the PREVAILING RATES. NO escalation clauses are to be included in the respondent's proposal and NO escalation clauses will be in the Contract Agreement. Respondent is to anticipate any future increases and include these costs in the proposal response. Contractor's invoices will not be paid if certified payrolls are incomplete, incorrect or not received in a timely manner.

All Apprentices must be registered with the State of Connecticut and their number shall not exceed the number allowed by law. Otherwise, all workers must be paid at least the Journeyman rate listed including benefits.

OSHA SAFETY AND HEALTH CERTIFICATION

Effective July 1, 2009: Any Mechanic, Laborer, or Worker, who performs work in a classification listed on the prevailing wage rate schedule on any public works project covered under C.G.S. Section 31-53, both on site and on or in the public building, must have completed a federal OSHA Safety and Health course within the last 5 years.

19. Each bid shall also include a description of three similar (3) projects completed by the bidder with references to demonstrate successful experience with similar projects. Please provide project name, contact information and contract value.

20. **Compliance with Town Ordinance Prohibiting Natural Gas Waste & Oil Waste From Natural Gas Extraction Activities or Oil Extraction Activities:** If this bid is for the construction, repair or maintenance of Town owned and/or maintained roads or real property within the Town related to either (a) the purchase or acquisition of materials by the Town to be used to construct, repair or maintain any Town owned and/or maintained road or real property within the Town or (b) the performance of services for the Town to construct, repair or maintain any Town owned and/or maintained road or real property within the Town, the Bidder shall provide the following signed statement to the Town in its bid response, which shall be a certification under penalty of perjury by the Bidder:

"The undersigned Bidder, _____, hereby submits a bid for materials, equipment and/or services for the Town of Glastonbury. The bid is for bid documents titled "GL-2023-35 Storm Drainage and Catch Basin Rehabilitation".

The undersigned Bidder hereby certifies under penalty of perjury that in connection with the bid and, if it is awarded the purchase order or contract by the Town, in connection with any purchase order or contract: (1) no materials containing natural gas waste or oil waste from natural gas extraction activities or oil extraction activities shall be provided to the Town or shall be used in providing any services to the Town by the undersigned Bidder or any contractor, sub-contractor or agent of the undersigned Bidder; (b) nor will the undersigned Bidder or any contractor, subcontractor or agent of the undersigned Bidder apply any natural gas waste or oil waste from

**STORM DRAINAGE AND CATCH BASIN REHABILITATION
LOCATED ON VARIOUS TOWN ROADS
INFORMATION FOR BIDDERS**

BID #GL-2023-35

natural gas extraction activities or oil extraction activities to any publicly owned and/or maintained road or real property within the Town of Glastonbury in performing its obligations under the purchase order or contract.

The undersigned Bidder hereby agrees and acknowledges that this requirement shall be a term of the purchase order or contract, if it awarded the purchase order or contract by the Town, and any breach of this provision shall be a breach of the purchase order or contract.”

21. Any technical questions regarding this bid shall be made in writing (email acceptable) and directed to Stephen Braun, Assistant Town Engineer, 2155 Main Street, PO Box 6523, Glastonbury, CT 06033; stephen.braun@glastonbury-ct.gov. Telephone (860) 652-7743 between the hours of 8:00 a.m. – 4:30 p.m. For administrative questions concerning this bid/proposal, please contact Gina Consiglio, Purchasing Agent, by email to the Purchasing Department at purchasing@glastonbury-ct.gov. All questions, answers, and/or addenda, as applicable, will be posted on the Town’s website at www.glastonbury-ct.gov (Upon entering the website scroll down to click on Bids & Proposals Icon, then scroll down page to see the active bid table. You must click the Bid Title to view all bid details and document links). The request must be received at least five (5) business days prior to the advertised response deadline. **It is the respondent’s responsibility to check the website for addenda prior to submission of any bid/proposal.**

IMPORTANT:

- Failure to comply with general rules may result in disqualification of the Bidder.
- Municipal projects are exempt from Federal Excise Taxes, as well as, State of Connecticut Sales, Use and Service Taxes and should not be include in the Bidder’s proposal.

**STORM DRAINAGE AND CATCH BASIN REHABILITATION
LOCATED ON VARIOUS TOWN ROADS
GENERAL CONSTRUCTION SPECIFICATIONS**

BID #GL-2023-XX

01.00 WORKMANSHIP, MATERIALS AND EMPLOYEES

01.01 Wherever in this contract the word "Engineer" is used, it shall be understood as referring to the Town Engineer/Manager of Physical Services of the Town of Glastonbury acting personally or through any assistants duly authorized.

01.02 The entire work described herein shall be completed in accordance with the plans and specifications to the full intent and meaning of the same. Unless otherwise specified, all materials incorporated in the permanent work shall be new, and both workmanship and material shall be of good quality. The Contractor shall, if required, furnish satisfactory evidence as to the kind and quality of materials.

01.03 The wording "furnish", "install", "construct", "furnish and install", or any similar terms, unless specifically noted to the contrary, shall include all labor, materials, water, tools, equipment, light, power, transportation, and any other services required for the completion of the work.

01.04 The Contractor shall at all times enforce strict discipline and good order among his employees, and shall seek to avoid employing on the work any unfit person or anyone not skilled in the work assigned to him.

02.00 SUPERINTENDENT

02.01 The Contractor shall keep on the work during its progress, in the absence of the Contractor, a competent Superintendent. The Superintendent shall be acceptable to the Engineer and shall fully represent the Contractor. All directions given to the Superintendent shall be binding as if given to the Contractor.

03.00 PRECONSTRUCTION MEETING

03.01 A Preconstruction Meeting will be held with the Engineer, Contractor, and any private utility company prior to commencing any work. The Engineer shall arrange the meeting based on a mutually convenient time.

04.00 PERMITS

04.01 Other than local permits, all permits, licenses, and fees required for the performance of the Contract work shall be secured and paid for by the Contractor.

05.00 PROPERTY ACCESS

05.01 The Contractor shall take all proper precautions to protect from injury or unnecessary interference, and provide proper means of access to abutting property where the existing access is cut off by the Contractor.

05.02 The Contractor shall take all proper precautions to protect persons from injury or unnecessary inconvenience and leave an unobstructed way along the public and private places for travelers, vehicles, and access to hydrants.

05.03 The Contractor shall make arrangements with the adjacent property owners for such trespass as he may reasonably anticipate in the performance of the work. All such arrangements shall be reported, in writing, to the Engineer.

06.00 PROTECTION OF THE PUBLIC AND OF WORK AND PROPERTY

- 06.01 The Contractor shall continuously maintain adequate protection of all work from damage, and shall take all reasonable precautions to protect the Town from injury or loss arising in connection with the Contract. Such barriers including temporary construction fence as directed by the Engineer, shall not be measured for payment, but rather included in the general cost of the work. Temporary signage shall be measured for payment under the Construction Signs pay item.
- 06.02 The Contractor shall adequately protect adjacent private and public property as provided by law and the Contract Documents.
- 06.03 The Contractor shall make good any damage, injury, or loss of his work and to the property of the Town resulting from lack of reasonable protective precautions.

07.00 EXISTING IMPROVEMENTS

- 07.01 The Contractor shall conduct his work so as to minimize damage to existing improvements. Except where specifically stated otherwise in the specifications, drawings, or as directed by the Engineer, it will be the responsibility of the Contractor to restore to their original condition, as near as practical, all improvements on public or private property. This shall include:
- a. Property within and adjacent to the side of installation such as shrubs, walks, driveways, fences, etc.
 - b. Utility mains, ducts, poles, and services. The Contractor is hereby notified that utilities, if/where shown on the plans, are at approximate locations. These locations are subject to possible errors in the source of information and errors in transcription. The Contractor shall make certain of the exact location of all mains, ducts, poles, and services prior to excavation.

08.00 SEPARATE CONTRACTS

- 08.01 The Engineer reserves the right to let other contracts in connection with this work. The Contractor shall afford other contractors reasonable opportunity for the introduction and storage of their materials and the execution of their work, and shall properly connect and coordinate his work with theirs. Wherever work being done by the Town of Glastonbury forces or by other contractors is contiguous to work covered by this Contract, the respective rights of the various interests involved shall be established by the Engineer to secure the completion of the various portions of the work.

09.00 INSPECTION OF WORK

- 09.01 The Town shall provide sufficient personnel for the inspection of the work.
- 09.02 The Engineer shall at all times have access to the work whenever it is in preparation or progress, and the Contractor shall provide proper facilities for such access and for inspection.

**STORM DRAINAGE AND CATCH BASIN REHABILITATION
LOCATED ON VARIOUS TOWN ROADS
GENERAL CONSTRUCTION SPECIFICATIONS**

BID #GL-2023-XX

09.03 If the specifications or the Engineer's instructions require any work to be specially tested or approved, the Contractor shall give the Engineer timely notice of its readiness for inspection and, if the inspection is by another authority other than the Engineer, of the date fixed for such inspection. Inspections by the Engineer shall be made promptly. If any work should be covered up without approval or consent of the Engineer, it must, if required by the Engineer, be uncovered for examination and properly restored at the Contractor's expense.

09.04 Re-inspection of any work may be ordered by the Engineer. If such work is found to be in accordance with the Contract Documents, the Town shall pay the cost of re-inspection and replacement. If such work is not in accordance with the Contract Documents, the Contractor shall pay such cost.

10.00 RIGHT TO INCREASE OR DECREASE WORK

10.01 The Town shall have the right to increase or decrease the amount of work herein specified as may be required.

11.00 RIGHT OF ENGINEER TO STOP WORK FOR WEATHER CONDITIONS

11.01 Should the work, in the opinion of the Engineer, be in danger by reason of inclemency of weather, or could not be finished in time to prevent such danger, the Contractor shall cease operations upon order of the Engineer, and shall not resume them until ordered to do so by the Engineer when the weather conditions are favorable. The Contractor shall, upon such orders, discontinue work, remove all materials or appliances for or in use upon the work, and place the streets in proper condition for use by the public during the time the work is suspended as herein provided, without cost to the Town.

12.00 CONTRACTOR TO BE RESPONSIBLE FOR IMPERFECT WORK OR MATERIALS

12.01 Any faithful work or imperfect material that may be discovered before the acceptance and the payment of the work shall be corrected upon the order of the Engineer. The acceptance and payment of the work does not in any manner relieve the Contractor of his obligation to construct work in the proper manner and the use of materials herein specified.

13.00 TOWN MAY NOTIFY CONTRACTOR IF WORK IS NOT CARRIED ON SATISFACTORILY

13.01 If, in the opinion of the Engineer, the Contractor is not proceeding with the work at a sufficient rate of progress so as to finish in the time specified, or has abandoned said work, or is not complying with the terms and stipulations or the Contract and specifications, the Engineer may serve notice on the Contractor to adopt such methods as will ensure the completion of the work in the time specified.

13.02 If, within five days after the Engineer has notified the Contractor that his work is not being carried on satisfactorily as before mentioned, the Engineer shall have the right to annul the Contract and manage the work under the direction of the Engineer, or re-let, for the very best interest of the Town as a new contract, the work under said new Contract shall be considered the responsibility of the defaulting Contractor.

**STORM DRAINAGE AND CATCH BASIN REHABILITATION
LOCATED ON VARIOUS TOWN ROADS
GENERAL CONSTRUCTION SPECIFICATIONS**

BID #GL-2023-XX

13.03 Additional costs incurred over and above the original Contract shall be borne by the Contractor.

14.00 DEDUCTIONS FOR UNCORRECTED WORK

14.01 If the Engineer deems it inexpedient to correct work that has been damaged or that was not done in accordance with the Contract, an equitable deduction from the Contract price shall be made therefor.

14.02 The Contractor shall promptly remove from the premises all materials condemned by the Engineer as failing to meet Contract requirements, whether incorporated in the work or not, and the Contractor shall promptly replace and re-execute his own work in accordance with the Contract and without expense to the Town, and shall bear the expense of making good all work by other contractors destroyed or damaged by such removal or replacement.

14.03 If the Contractor does not remove such condemned work and materials as promptly as possible after written notice, the Engineer may remove them and store the materials at the expense of the Contractor.

15.00 CLEANING UP

15.01 The Contractor must remove all debris of every description as the work progresses and leave the surroundings in a neat and orderly condition to the satisfaction of the Engineer.

15.02 Upon completion, and before acceptance and final payment, the Contractor shall remove from the site all equipment, forms, surplus material, rubbish and miscellaneous debris and leave the site in a neat and presentable condition.

16.00 ROYALTIES AND PATENTS

16.01 The Contractor shall pay all royalties and license fees. He shall defend all suits or claims for infringement of any patent rights and shall save the Town of Glastonbury harmless from loss on account thereof, except that the Town of Glastonbury shall be responsible for all such loss when a particular manufacturer, product, or process is specified by the Town of Glastonbury.

**STORM DRAINAGE AND CATCH BASIN REHABILITATION
LOCATED ON VARIOUS TOWN ROADS
SPECIAL CONDITIONS**

BID #GL-2023-35

01.00 NOTICE TO CONTRACTOR

01.01 **Intent of Contract:** The intent of the Contract is to prescribe a complete work or improvement that the Contractor undertakes to do, in full compliance with the specifications, plans, special provisions, proposal, and Contract. The Contractor shall perform all work in close conformity with the lines, grades, typical cross-sections, dimensions, and other data shown on the plans or as modified by written orders, including the furnishing of all materials, implements, machinery, equipment, tools, supplies, transportation, labor, and all other things necessary to the satisfactory prosecution and completion of the project.

Much time and effort has gone into this project in an effort to minimize impact on trees and adjacent properties. Extreme care shall be taken by the Contractor to honor commitments made by the Town. Prior to doing any work, the Contractor should meet with the Engineer to become familiar with the conditions encountered and commitments made.

01.02 The Contractor is hereby alerted to the fact that the State of Connecticut Department of Transportation Standard Specifications for Roads, Bridges, Facilities and Incidental Construction, Form 818 (Form 818) 2020 latest edition including supplements thereto dated July 2022, are the governing specifications and are to be considered part of the Contract Documents. The Form 818 shall not be provided by the Town and any cost associated therewith shall be the responsibility of the Contractor. In case of any discrepancy between the Contract Drawings or Specifications and the Form 818, the matter shall immediately be submitted to the Engineer. The Engineer shall have sole authority in resolving any discrepancies.

01.03 This Contract includes storm drainage pipe replacement and catch basin rehabilitation work located on the list of roads below within the Town of Glastonbury.

Catch Basin Rehabilitation located on the following streets:

1. CAVAN LANE
2. CRESTDALE ROAD
3. FAIRVIEW TERRACE
4. GLENWOOD ROAD
5. GRINDLE BROOK ROAD
6. ORCHARD STREET (HEBRON AVENUE TO CHASE HOLLOW LANE)
7. STRICKLAND STREET (TREAT ROAD TO SAND HILL LANE)
8. TARA LANE

Storm Drainage Pipe Replacement locations on the following streets:

STREET	BEGIN CATCH BASIN LOCATION	END CATCH BASIN LOCATION	LENGTH OF PIPE	PIPE DIAMETER
CAVAN LANE	#210 CAVAN LANE	#213/#219 CAVAN LANE	24 L.F.	15"
CAVAN LANE	#240 CAVAN LANE	#237 CAVAN LANE	24 L.F.	15"
CAVAN LANE	#260 CAVAN LANE	#261 CAVAN LANE	24 L.F.	15"
CAVAN LANE	#291 CAVAN LANE	#279 CAVAN LANE	110 L.F.	24"
CAVAN LANE	#312 CAVAN LANE	#313 CAVAN LANE	24 L.F.	15"

**STORM DRAINAGE AND CATCH BASIN REHABILITATION
LOCATED ON VARIOUS TOWN ROADS
SPECIAL CONDITIONS**

BID #GL-2023-35

STREET	BEGIN CATCH BASIN LOCATION	END CATCH BASIN LOCATION	LENGTH OF PIPE	PIPE DIAMETER
CAVAN LANE	#306 CAVAN LANE	#312 CAVAN LANE	125 L.F.	24"
CRESTDALE ROAD	#37 CRESTDALE ROAD	#38 CRESTDALE ROAD	24 L.F.	15"
CRESTDALE ROAD	#62 CRESTADLE ROAD	#71 CRESTDALE ROAD	24 L.F.	15"
TARA DRIVE	#960 HEBRON AVENUE	#47 TARA DRIVE	120 L.F.	15"
TARA DRIVE	#19 TARA DRIVE	#27 TARA DRIVE	100 L.F.	15"

Storm drainage pipe replacement consists of the removal of the existing corrugated metal pipe (CMP) and replacement of the storm drainage pipe with reinforced concrete pipe (RCP) of the same size and installed to the existing lines and grades from the catch basin structure locations listed in the table above. Prior to construction, town forces will field verify the storm drainage pipe replacement limits and catch basin rehabilitation locations with the contractor.

The Town of Glastonbury reserves the right to increase or decrease the scope of work included in this bid as described in Special Conditions Section 14.00 based on the availability of Town crews to perform portions of this work and as required for the Town to meet schedule obligations and available funding. The additional contract time needed to support any increase in Scope of Work will be negotiated with the Contractor.

01.05

Storm drainage pipe replacement and catch basin rehabilitation improvements located on the various streets outlined within this contract are being performed in preparation for a town administered full depth pavement reclamation or milling and paving work to be completed by others under a separate contract. Completion date described under Special Conditions Section 11.00 is **required** in order to meet full depth pavement reclamation, milling and paving schedules obligated under these other contracts. Contractor shall be prepared to mobilize all resources necessary to comply with the completion date stipulated.

The Town also reserves the right to expand the scope of work to include additional storm drainage replacement and catch basin rehabilitation on other roads at the unit prices indicated in this contract. The required completion date for any such extra work would be determined based on mutual agreement with the contractor.

01.06

Reset Catch Basins: All catch basins identified for reset shall have the existing tops removed for re-use or disposal as determined by the Engineer. The structure shall be demolished to the limits of deteriorated concrete as determined in the field or as directed by the Engineer. New concrete brick and/or block shall then be installed as required to replace the deteriorated portion of the structure and the interior of the structure shall be repointed to repair all other interior defects. Reconstruction of demolished portions of catch basins utilizing pre-cast components is acceptable.

The new catch basin top, frame, and grate will be paid for separately at the contract unit price each for such "(Type) Catch Basin Top" complete in place.

01.07

Catch Basin Tops: All replacement catch basin tops within the project limits are for bituminous concrete lip curbing unless otherwise denoted on the plans. All replacement

**STORM DRAINAGE AND CATCH BASIN REHABILITATION
LOCATED ON VARIOUS TOWN ROADS
SPECIAL CONDITIONS**

BID #GL-2023-35

catch basin tops shall be reset to its original elevation. Vertical layout elevation control for each catch basin top replacement is the responsibility of the contractor. Re-use of an existing catch basin top shall be determined by the Engineer.

- 01.08 **Sawcutting of Bituminous Concrete:** Sawcutting of the bituminous pavement required for the replacement of the storm drainage pipes under this contract will not be measured for payment but the cost shall be considered included in the contract bid price for "Temporary Pavement".
- 01.09 Contractor is required to confine their work area to a single street unless otherwise approved by the Engineer. Catch Basin rehabilitation work area shall be confined to a single lane in the same direction progressing up one side and down the other to complete one street at a time.
- 01.10 At the end of each day, the contractor is required to have each work area location completely stabilized for safe passage of traffic. This includes securing the new catch basin frame and grate to the structure and installation of full depth bituminous patch installed to grade. Overnight plating of any open excavation(s) will not be allowed.
- 01.11 The Contractor shall ensure that suitable temporary access is provided to all residential and commercial driveways at all times as described in the Special Provision for Maintenance and Protection of Traffic.
- 01.12 Limitations on work hours are described in Special Conditions Section 17.00 and in the Special Provisions. The Contractor shall understand and strictly comply with these limitations.

02.00 COMMUNICATIONS

- 02.01 All notices, demands, requests, instructions, approvals, proposals, and claims must be in writing.
- 02.02 Any notice to, or demand upon, the Contractor shall be sufficiently given if delivered at the office of the Contractor stated on the signature page of the Agreement (or at such other office as the Contractor may, from time to time, designate) in a sealed, postage-prepaid envelope or delivered with charges prepaid to any telegraph company for transmission, in each case addressed to such office.
- 02.03 All papers required to be delivered to the Town shall, unless otherwise specified in writing to the Contractor, be delivered to the Town Engineer/Manager of Physical Services, 2155 Main Street, Glastonbury, CT 06033, and any notice to, or demand upon, the Town shall be delivered at the above address in a sealed, postage-prepaid envelope or delivered with charges prepaid to any telegraph company for transmission, in each case addressed to such office or to such other representatives of the Town, or to such other address as the Town may subsequently specify in writing to the Contractor for such purpose.
- 02.04 Any such notice shall be deemed to have been given as of the time of actual delivery or, in case of mailing, when the same should have been received in due course of post or, in the case of telegrams, at the time of actual receipt, as the case may be.

03.00 PARTIAL USE OF IMPROVEMENTS

03.01 The Town may, at its election, give notice to the Contractor and place in use those sections of the work that have been completed, inspected and can be accepted as complying with the Contractor Documents and if, in its opinion, each such section is reasonably safe and fit for the use and accommodation for which it was intended, provided:

- a. The use of such sections of the work shall not materially impede the completion of the remainder of the work by the Contractor.
- b. The Contractor shall not be responsible for any damages or maintenance costs due directly to the use of such sections.
- c. The use of such sections shall in no way relieve the Contractor of his liability due to having used defective materials or to poor workmanship.
- d. The period of guarantee shall not begin until the date of the final acceptance of all work required under this Contract.

04.00 INSURANCE

04.01 The Bidder shall, at its own expense and cost, obtain and keep in force during the entire duration of the Project or Work the following insurance coverage covering the Bidder and all of its agents, employees and sub-contractors and other providers of services and shall name the **Town of Glastonbury and the State of Connecticut and their employees and agents as an Additional Insured** on a primary and non-contributory basis to the Bidders Commercial General Liability and Automobile Liability policies. **These requirements shall be clearly stated in the remarks section on the Bidders Certificate of Insurance.** Insurance shall be written with insurance carriers approved in the State of Connecticut and with a minimum Best's Rating of A-VIII. In addition, all carriers are subject to approval by the Town. Minimum Limits and requirements are stated below:

- a. Worker's Compensation Insurance:
 - Statutory Coverage
 - Employer's Liability
 - \$1,000,000 each accident/\$1,000,000 disease-policy limit/\$1,000,000 each employee
 - A Waiver of Subrogation shall be provided in favor of the Town of Glastonbury and the State of Connecticut and their employees and agents
- b. Commercial General Liability:
 - Including Premises and Operations, Products and Completed Operations, Personal and Advertising Injury, Contractual Liability and Independent Contractors
 - Limits of Liability for Bodily Injury and Property Damage
Each Occurrence: \$1,000,000
Aggregate: \$2,000,000
(The Aggregate Limit shall apply separately to each job.)
 - A Waiver of Subrogation shall be provided in favor of the Town of Glastonbury and the State of Connecticut and their employees and agents
- c. Automobile Insurance:
 - Including all owned, hired, borrowed, and non-owned vehicle
 - Limit of Liability for Bodily Injury and Property Damage
Per Accident: \$1,000,000

**STORM DRAINAGE AND CATCH BASIN REHABILITATION
LOCATED ON VARIOUS TOWN ROADS
SPECIAL CONDITIONS**

BID #GL-2023-35

- A Waiver of Subrogation shall be provided in favor of the Town of Glastonbury and the State of Connecticut and their employees and agents

d. Umbrella of Excess Liability:

- State in the Remarks Section that coverage is follow form.
- Limit of Liability Each Occurrence \$1,000,000
Aggregate \$1,000,000

04.02 The Bidder shall direct its Insurer to provide a Certificate of Insurance to the Town before any work is performed. The Contractor shall be responsible to notify the Town **60 days** in advance with written notice of cancellation or non-renewal. The Certificate shall evidence all required coverage. The Bidder shall provide the Town copies of any such insurance policies upon request.

04.03 INDEMNIFICATION: To the fullest extent permitted by law, the Contractor shall indemnify and hold harmless the Town and the State of Connecticut and its consultants, agents, and employees from and against all claims, damages, losses and expenses, direct, indirect or consequential (including but not limited to fees and charges of engineers, attorneys and other professionals and court and arbitration costs) to the extent arising out of or resulting from the performance of the Contractor's work, provided that such claim, damage, loss or expense is caused in whole or in part by any negligent act or omission by the Contractor, or breach of its obligations herein or by any person or organization directly or indirectly employed or engaged by the Contractor to perform or furnish either of the services, or anyone for whose acts the Contractor may be liable.

05.00 WORK BY OTHERS

05.01 Private utilities, contractors, developers or other parties may be expected to be working within the Contract area during this Contract. It shall be the responsibility of the Contractor to coordinate his work with the work being done by others in order that the construction shall proceed in an efficient and logical manner. The Contractor shall have no claim or claims whatever against the Town, the Engineer, or other parties due to delays or other reasons caused by the work by others or his failure to coordinate such work.

06.00 CONTRACTOR'S WORK AND STORAGE AREA

06.01 The Contractor shall contact the Town to determine if any specific locations will be designated, or gain its approval prior to using any area for storage of equipment, materials and trailers during the period of this Contract. The Contractor shall confine his work/storage area to the limits as designated or approved and shall be responsible for the security of the work/storage area. Upon completion of the Contract, the Contractor shall remove all equipment and materials, except as otherwise specified, and restore the site to its original condition as approved by the Engineer and at no cost to the Town.

07.00 DISPOSAL AREA

07.01 The Tryon Street Bulky Waste Facility will be available to the Contractor, at no charge, for disposal of materials that are accepted at that facility. Prior to any disposal, the Contractor is required to register all vehicles being utilized for disposal and obtain a permit for each vehicle from the Sanitation Department. Waste disposal guidelines for the Bulky Waste facility are published on the Town web site at the addresses shown below. Each bidder shall have reviewed and understand these guidelines prior to submitting a bid for the project.

**STORM DRAINAGE AND CATCH BASIN REHABILITATION
LOCATED ON VARIOUS TOWN ROADS
SPECIAL CONDITIONS**

BID #GL-2023-35

[Bulky Waste Facility | Glastonbury, CT \(glastonburyct.gov\)](http://www.glastonburyct.gov)

[WASTE DISPOSAL GUIDELINES \(glastonburyct.gov\)](http://www.glastonburyct.gov)

[Refuse Disposal Permits | Glastonbury, CT \(glastonburyct.gov\)](http://www.glastonburyct.gov)

Holiday Schedule: <https://www.glastonburyct.gov/departments/department-directory-i-z/refuse-disposal-sanitation/bulky-waste-facility>

Acceptable materials generally include such materials as brush, stumps, demolition materials, and excess excavated earth materials. Unacceptable materials generally include such items as carpet, appliances, upholstered furniture; hazardous wastes such as pesticides, oil based paints and thinners; or other wastes as designated by the State Department of Energy and Environmental Protection. Demolition material cannot contain asbestos or other hazardous materials.

The Contractor shall obtain a disposal area for all other unsuitable or surplus materials at no cost to the Town.

08.00 DUST CONTROL

08.01 During the progress of the work, the Contractor shall conduct his operations and maintain the area of his activities so as to minimize the creation and dispersion of dust. If the Engineer decides that it is necessary to use water or calcium chloride for more effective dust control, the Contractor shall furnish and spread the material, as directed, without additional compensation.

09.00 MAINTENANCE / GUARANTEE PERIOD

09.01 The Contractor shall be held responsible to the Town for maintenance with respect to defects, settlements, etc. for a minimum period of one-year following the date of final acceptance of the project by the Town.

10.00 PROTECTION OF EXISTING UTILITIES

10.01 Prior to opening an excavation, effort shall be made to determine whether underground installations, (i.e., sewer, water, fuel, electric lines, etc.) will be encountered and, if so, where such underground installations are located. Before starting any excavation, the Contractor shall submit to the Engineer plans or details showing the proposed method the Contractor will use to support and protect all existing utilities during construction. The furnishing of such plans and details shall not serve to relieve the Contractor of any responsibility for the proper conduct of the work.

10.02 When the excavation approaches the estimated location of such an installation, the exact location shall be determined by careful probing or hand digging, and when it is uncovered, proper supports shall be provided for the existing installation. Utility companies shall be contacted and advised of proposed work prior to the start of actual excavation.

10.03 There will be no extra payment for submitting plans or details or for any work related to supporting and protecting all existing utilities during construction.

11.00 TIME FOR COMPLETION/NOTICE TO PROCEED

11.01 The work under this Contract shall commence on or around **July 1, 2023** or on the date ordered by the Engineer in the Notice to Proceed. All contract work shall be completed

**STORM DRAINAGE AND CATCH BASIN REHABILITATION
LOCATED ON VARIOUS TOWN ROADS
SPECIAL CONDITIONS**

BID #GL-2023-35

within 75 calendar days of the start date listed in the Notice to Proceed. Contract work on the streets listed below shall be completed sequentially on or before the dates specified in order to meet the Town of Glastonbury roadway paving schedule.

1. Cavan Lane, Crestdale Road, Tara Lane and Orchard Street (Hebron Avenue to Chase Hollow Lane) work shall be completed on or before **July 30, 2023**.
2. Fairview Terrace and Grindle Brook Road work shall be completed on or before **August 15, 2023**.
3. Glenwood Road and Strickland Street (Treat road to Sand Hill Lane) work shall be completed on or before **August 30, 2023**.

Within five (5) business days after the date of the Notice of Award, the Contractor must provide the appropriate bond and insurance certificates to the Town Purchasing Agent and must be issued a Notice to Proceed and Purchase Order for the Project prior to initiating any work.

11.02 When the Contract time is stated on a calendar-day basis, that time shall be the number of consecutive calendar days contained in the Contract period, excluding the time period from each December 1 through the following March 31 (the "winter shutdown period"). The time will be computed as herein provided on a consecutive-day basis, including all Saturdays, Sundays, holidays, and non-work days from April 1 through November 30 of each included year. Time will not be charged for days in the winter shutdown period. If the Engineer so approves, the Contractor may work on certain tasks of the Project during the winter shutdown period with no charge being made against the Contract time. **If work during winter shut down is approved by the Town, approval may be granted with the condition that work under the items Trafficperson (Municipal Police Officer) or Trafficperson (Uniformed Flagger) will not be measured for payment, at the discretion of the Town.**

12.00 LIQUIDATED DAMAGES

12.01 As actual damages for any delay in completion of the work that the Contractor is required to perform under this Contract are impossible to determine, the Contractor and the Sureties shall be liable for and shall pay to the Town the sum of \$500.00 as fixed, agreed and liquidated damages for each calendar day of delay from the above-stipulated completion, or completion as modified in writing by both parties, until such work is satisfactorily completed and accepted.

13.00 SCHEDULE OF DRAWINGS

13.01 No drawings are contained within this contract. All contract work locations and limits are identified in Special Conditions Section 01.03.

14.00 CHANGES IN THE WORK

14.01 The Town reserves the right to remove portions of the work indicated on the plans and specifications from the Contract or to self-perform portions of the work in order to meet schedule or funding obligations as may be required. The reduction in the scope work to be performed by the Contractor shall be made without invalidating the Contract or the unit prices there-in. Whenever work is done by the Town contiguous to other work covered by this Contract, the Contractor shall provide reasonable opportunity for the execution of the work and shall properly coordinate his work with that of the Town.

**STORM DRAINAGE AND CATCH BASIN REHABILITATION
LOCATED ON VARIOUS TOWN ROADS
SPECIAL CONDITIONS**

BID #GL-2023-35

15.00 LAYOUT OF WORK

15.01 The Contractor is responsible to provide stake-out of the work in accordance with the plans and specification under the item for "Construction Surveying".

16.00 REMOVAL AND STORAGE OF MATERIALS AND STRUCTURES FOUND ON THE WORK

16.01 All salvable materials, including traffic signal equipment, topsoil, gravel, fill materials, etc. and structures, including drainage pipes, catch basins and manhole frames and covers, guide railing, etc. that are not to remain in place or that are not designated for use in the work, shall be carefully removed by the Contractor and delivered to the Town Highway Garage located at 2380 New London Turnpike. All salvable materials removed and stored shall remain the property of the Town. The Engineer shall determine the materials or structures to be salvaged.

17.00 PROSECUTION AND PROGRESS

17.01 **ADVANCE NOTICE:** The Contractor shall give the Engineer a seven-day advance written notice of construction activities that will alter traffic patterns that result in lane shifts, detours, temporary closures of lane(s), permanent closure of lane(s), or lane reductions. This advance notification will allow the Town to publish news releases and/or provide public radio announcements to inform the public of revised traffic patterns or possible traffic delays. Failure of the Contractor to provide such timely notice shall be considered a breach of Contract and will subject the Contractor to stop work orders until such time as the seven-day notice has been satisfied.

17.02 Work hour limitations are described in the Special Provision for Section 1.08 Prosecution and Progress. Work on weekends or during time periods other than those described will not be permitted. No work will be allowed on designated Town Holidays unless permission is granted by the Town.

18.00 EXTRA WORK AND RETAINAGE

18.01 Extra and cost plus work shall be governed by Article 1.04.05 and Article 1.09.04 of the Form 818.

18.02 Article 1.09.06, Part A, Item 1 of the Form 818 is hereby modified as follows: Retainage shall be withheld in the amount of five (5) percent. Release of retainage shall be made upon final acceptance of the project by the Town.

19.00 SUBMITTALS AND MATERIALS TESTING

19.01 Contractor shall provide shop drawings, materials certificates, material samples, and other submittals for material testing in conformance with these specifications. A list of required submittals is located in Section 1.06- Control of Materials of these specifications.

**STORM DRAINAGE AND CATCH BASIN REHABILITATION
 LOCATED ON VARIOUS TOWN ROADS
 BID PROPOSAL**

BID #GL-2023-35

TOWN OF GLASTONBURY			
BID / PROPOSAL		GL # 2023-35	
DATE ADVERTISED	MAY 10, 2023	DATE / TIME DUE	MAY 31, 2023 at 11:00 A.M.
NAME OF PROJECT		STORM DRAINAGE AND CATCH BASIN REHABILITATION	

IT IS THE RESPONSIBILITY OF THE BIDDER TO CHECK THE TOWN'S WEBSITE BEFORE SUBMITTING BID FOR ADDENDA POSTED PRIOR TO BID OPENING.

THE BIDDER ACKNOWLEDGES RECEIPT OF THE FOLLOWING ADDENDA. AS REQUIRED:

Addendum #1 _____ (initial/date) Addendum #2 _____ (initial/date) Addendum #3 _____ (initial/date)

OTHER ITEMS REQUIRED WITH SUBMISSION OF BID PROPOSAL:

The following bid checklist describes items required for inclusion with the above-referenced bid proposal package. It is provided for the convenience of the bidders and, therefore, should not be assumed to be a complete list.

- _____ 1. Included a copy of the Bid Bond as per Section 9 of the Information for Bidders. Original Bond to be mailed as specified herein.
- _____ 2. Included Disclosure of Past and Pending Mediation, Arbitration, and Litigation cases against the Bidder or its Principals as per Section 16 of the Information for Bidders.
- _____ 3. Included Qualifications Statement as per Section 19 of the Information for Bidders.
- _____ 4. Provided certification for Compliance with Town Ordinance Prohibiting Natural Gas Waste & Oil Waste From Natural Gas Extraction Activities or Oil Extraction Activities as per Section 20 of the Information for Bidders
- _____ 5. Checked Town web site for Addenda and acknowledged Addenda on page BP-1.
- _____ 6. Acknowledged Code of Ethics on page BP-5.
- _____ 7. Prepared ONE consolidated pdf file for on-line bid submission.

BIDDER NAME: _____

**STORM DRAINAGE AND CATCH BASIN REHABILITATION
 BID PROPOSAL**

BID #GL-2023-35

BIDDER NAME: _____

<u>LINE NO.</u>	<u>ITEM NO.</u>	<u>ITEM DESCRIPTION</u>	<u>UNIT</u>	<u>QTY</u>	<u>UNIT PRICE</u>	<u>EXT</u>
1	0406002 A	Temporary Pavement	SY	238		
2	0586601	Reset Type "C" Catch Basin	EA	74		
3	0586603	Reset Type "C" Catch Basin Double Gate Type 1	EA	1		
4	0586620	Reset Type "C-L" Catch Basin	EA	10		
5	0586750	Type "C" Catch Basin Top	EA	74		
6	0586751	Type "C" Catch Basin Top Double Gate Type 1	EA	1		
7	0586760	Type "C-L" Catch Basin Top	EA	10		
8	0686000.15	15" R.C. Pipe- 0'-10' Deep	LF	364		
9	0686000.24	24" R.C. Pipe- 0'-10' Deep	LF	235		
10	0944000 A	Furnish and Placing Topsoil	SY	389		
11	0950005 A	Turf Establishment	SY	389		
12	0970007 A	Trafficperson (Uniformed Flagger)	HR	480		
13	0971001 A	Maintenance and Protection of Traffic	LS	1		
14	0975004	Mobilization and Project Closeout	LS	1		
15	0977001	Traffic Cone	EA	30		
16	0980020	Construction Surveying	LS	1		
17	1220013	Construction Signs- Bright Florescent Sheeting	SF	142		

**STORM DRAINAGE AND CATCH BASIN REHABILITATION
 BID PROPOSAL**

BID #GL-2023-35

BIDDER NAME: _____

LINE NO.	ITEM NO.	ITEM DESCRIPTION	<u>UNIT</u>	<u>QTY</u>	<u>UNIT PRICE</u>	<u>EXT</u>
TOTAL BID AMOUNT:					\$ _____	(Numeric)

WRITTEN TOTAL BID AMOUNT: _____

Note:

In the event that the Town finds computational errors in a respondent's bid proposal, the bid total cost shall be recalculated by the town based on the **unit prices** contained in the bid proposal

BID ALTERNATES:

	<u>ITEM DESCRIPTION</u>	<u>UNIT</u>	<u>QTY</u>	<u>UNIT PRICE</u>	<u>EXT.</u>
ALT. 1:	15" High Density Polyethylene Pipe- 0'-10' Deep	LF	364	_____	_____
ALT. 2:	24" High Density Polyethylene Pipe- 0'-10' Deep	LF	235	_____	_____

Note: Bid alternatives 1 and 2 will replace line items 8 and 9 respectively if selected by the Town

**STORM DRAINAGE AND CATCH BASIN REHABILITATION
BID PROPOSAL**

BID #GL-2023-35

BIDDER NAME: _____

CODE OF ETHICS:

I/We have reviewed a copy of the Town of Glastonbury's Code of Ethics and agree to submit a Consultant Acknowledgement Form if I/We are selected. Yes _____ No _____*

*Bidder is advised that effective August 1, 2003, the Town of Glastonbury cannot consider any bid or proposal where the Bidder has not agreed to the above statement.

NON-COLLUSION AFFIDAVIT:

By submission of this bid, the Bidder certifies, and in the case of a joint bid each party thereto certifies as to their own organization that this bid has been arrived at independently without consultation, communication, or agreement as to any matter relating to this bid with any other Bidder or with any competitor.

Respectfully submitted:

Type or Print Name of Individual

Doing Business as (Trade Name)

Signature of Individual

Street Address

Title

City, State, Zip Code

Date

Telephone Number/Fax Number

E-Mail Address

SS# or TIN#

(Seal – If bid is by a Corporation)

Attest

**STORM DRAINAGE AND CATCH BASIN REHABILITATION
LOCATED ON VARIOUS TOWN ROADS**

BID #GL-2023-35

SPECIAL PROVISIONS

INDEX TO SPECIAL PROVISIONS

This index has been prepared for the convenience of those using this contract with the sole express purpose of locating quickly the information contained herein; and no claims shall arise due to omissions, additions, deletions, etc., as this index shall not be considered part of the contract.

SECTION	DESCRIPTION	PAGE
	NOTICE TO CONTRACTOR - PROTECTION AND COORDINATION OF EXISTING UTILITIES	2
	NOTICE TO CONTRACTOR – UTILITY COMPANIES	2
	NOTICE TO CONTRACTOR – RESET CATCH BASINS	2
	NOTICE TO CONTRACTOR – CATCH BASIN TOPS	3
	NOTICE TO CONTRACTOR – SAWCUTTING OF BITUMINOUS PAVEMENT	3
	NOTICE TO CONTRACTOR – GENERAL PROJECT REQUIREMENTS	3
	SECTION 1.04 SCOPE OF WORK	4
	SECTION 1.05 CONTROL OF WORK	6
	SECTION 1.06 CONTROL OF MATERIALS	7
ITEM # 0406002A	TEMPORARY PAVEMENT	13
ITEM # 0944000A	FURNISHING AND PLACING TOPSOIL	15
ITEM # 0950005A	TURF ESTABLISHMENT	16
ITEM # 0970007A	TRAFFICPERSON (UNIFORMED FLAGGER)	19
ITEM # 0971001A	MAINTENANCE AND PROTECTION OF TRAFFIC	20

NOTICE TO CONTRACTOR - PROTECTION AND COORDINATION OF EXISTING UTILITIES

Existing utilities shall be maintained during construction except as specifically stated herein and/or noted on the plans and as coordinated with the utilities. The Contractor shall verify the location of underground, structure mounted and overhead utilities. Construction work within the vicinity of utilities shall be performed in accordance with current safety regulations.

The Contractor shall notify "Call Before You Dig", telephone: 8-1-1 or 1-800-922-4455 for the location of public utility, in accordance with Section 16-345 of the Regulations of the Department of Utility Control.

Representatives of the various utility companies shall be provided access to the work, by the Contractor.

Contractors are cautioned that it is their responsibility to verify locations, conditions, and field dimensions of all existing features, as actual conditions may differ from the information shown on the plans or contained elsewhere in the specifications.

The Contractor shall notify the Engineer prior to the start of work and shall be responsible for all coordination with the Town. The Contractor shall allow the Engineer complete access to the work.

The Contractor shall be liable for all damages or claims received or sustained by any persons, corporations or property in consequence of damage to the existing utilities, their appurtenances, or other facilities caused directly or indirectly by the operations of the Contractor.

Any damage to any existing private and public utility, as a result of the Contractors operations, shall be repaired to the utility's and Engineer's satisfaction at no cost to the Town or the Utilities, including ail materials, labor, etc., required to complete the repairs.

The Contractor's attention is directed to the requirements of Section 1.07.13 - "Contractor's Responsibilities for Adjacent Property and Services".

Prior to opening an excavation, effort shall be made to determine whether underground installations, i.e., water, sanitary, gas, electric ducts, communication ducts, etc., will be encountered and, if so, where such underground installations are located. When the excavation approaches the estimated location of such an installation, the exact location shall be determined by careful probing or hand digging, and when it is uncovered, proper supports shall be provided for the existing installation. Utility companies shall be contacted and advised of proposed work prior to the start of actual excavation, as noted above.

The Contractor shall coordinate all utility relocations with the respective utility company. The Contractor shall notify Connecticut Natural Gas two weeks in advance of the required gas valve box adjustments as shown on the plans.

NOTICE TO CONTRACTOR – UTILITY COMPANIES

It is understood that any references in the contract documents to Northeast Utilities, CL&P and/or Yankee Gas are meant to refer to Eversource.

It is understood that any references in the contract documents to AT&T is meant to refer to Frontier Communications.

NOTICE TO CONTRACTOR – RESET CATCH BASINS

All catch basins identified for reset shall have the existing tops removed for re-use or disposal as determined by the Engineer. The structure shall be demolished to the limits of deteriorated concrete as determined in the field or as directed by the Engineer. New concrete brick and/or block shall then be installed as required to

replace the deteriorated portion of the structure and the interior of the structure repointed. Reconstruction utilizing pre-cast component is also acceptable.

The new catch basin top, frame, and grate will be paid for separately at the contract unit price each for such "(Type) Catch Basin Top" complete in place

NOTICE TO CONTRACTOR – CATCH BASIN TOPS

All replacement catch basin tops within the project limits are for bituminous concrete lip curbing unless otherwise denoted on the plans. All replacement catch basin tops shall be reset to the original elevation. Vertical layout elevation control for each catch basin top replacement is the responsibility of the contractor. Re-use of an existing catch basin top shall be determined by the Engineer.

NOTICE TO CONTRACTOR – SAWCUTTING OF BITUMINOUS PAVEMENT

Sawcutting of the bituminous pavement required for the replacement of the storm drainage pipes under this contract will not be measured for payment but the cost shall be considered included in the contract bid price for "Temporary Pavement".

NOTICE TO CONTRACTOR – GENERAL PROJECT REQUIREMENTS

Contractor is required to confine their work area to a single street unless otherwise approved by the Engineer. Catch Basin rehabilitation work area shall be confined to a single lane in the same direction progressing up one side and down the other to complete one street at a time.

At the end of each day, the contractor is required to have each work area location completely stabilized for safe passage of traffic. This includes securing the new catch basin frame and grate to the structure and installation of full depth bituminous patch installed to grade. Overnight plating of any open excavation(s) will not be allowed.

Municipal police officers will be required for some work areas as directed by the Engineer: When Municipal Police Officers are required, the Contractor shall order such officers and submit any invoices for services to the Engineer for payment. Contractor will not be responsible for payment of police services unless work is not performed and services are not cancelled per the requirements of the police department. Contractor is required to submit Maintenance and Protection of Traffic Plans for review and approval of the Glastonbury Police Department.

The Contractor shall ensure that suitable temporary access is provided to all residential and commercial driveways at all times as described in the Special Provision for Maintenance and Protection of Traffic.

Limitations on work hours are described in Special Conditions Section 17.00. The Contractor shall understand and strictly comply with these limitations.

SECTION 1.04 SCOPE OF WORK

Article 1.04.01 – Intent of Contract is supplemented as follows:

The work under this contract consists of storm drainage pipe replacement of the existing corrugated metal pipe (CMP) and replacement of the storm drainage pipe with reinforced concrete pipe (RCP) of the same size and installed to the existing lines and grades from the catch basin structure locations listed in the table below. Additional work under this contract consists of the removal and replacement of existing catch basin frame and grates with new catch basin frames and grates of the type specified located on the list of roadways below. Prior to construction, town forces will field verify the storm drainage replacement limits and catch basin rehabilitation locations with the contractor.

The work under this contract is a portion of a town administered pavement rehabilitation program performed by a State of Connecticut Vendor In-Place Bid contractor and must be completed in advance of the commencement of any full depth reclamation or milling and paving operations. Coordination with the town project manager and scheduling will be essential.

Storm Drainage Pipe Replacement locations on the following streets:

STREET	BEGIN CATCH BASIN LOCATION	END CATCH BASIN LOCATION	LENGTH OF PIPE	PIPE DIAMETER
CAVAN LANE	#210 CAVAN LANE	#213/#219 CAVAN LANE	24 L.F.	15"
CAVAN LANE	#240 CAVAN LANE	#237 CAVAN LANE	24 L.F.	15"
CAVAN LANE	#260 CAVAN LANE	#261 CAVAN LANE	24 L.F.	15"
CAVAN LANE	#291 CAVAN LANE	#279 CAVAN LANE	110 L.F.	24"
CAVAN LANE	#312 CAVAN LANE	#313 CAVAN LANE	24 L.F.	15"
CAVAN LANE	#306 CAVAN LANE	#312 CAVAN LANE	125 L.F.	24"
CRESTDALE ROAD	#37 CRESTDALE ROAD	#38 CRESTDALE ROAD	24 L.F.	15"
CRESTDALE ROAD	#62 CRESTADLE ROAD	#71 CRESTDALE ROAD	24 L.F.	15"
TARA DRIVE	#960 HEBRON AVENUE	#47 TARA DRIVE	120 L.F.	15"
TARA DRIVE	#19 TARA DRIVE	#27 TARA DRIVE	100 L.F.	15"

List of Roadways:

Work at all of the following eight (8) locations listed below will include:

- Remove and dispose of existing catch basin tops
- Furnish and Install new catch basin tops
- Furnish and install temporary bituminous concrete patching

1. **Cavan Lane** – Orchard Street to Cul-de-sac
2. **Crestdale Road** – Cavan Lane to Cul-de-sac
3. **Fairview Terrace** – Foote Road to Cul-de-sac

4. **Glenwood Road** – Hebron Avenue to Cul-de-sac
5. **Grindle Brook Road** – Fairview Terrace to Cul-de-sac
6. **Orchard Street** – Hebron Avenue to Chase Hollow Lane
7. **Strickland Street** – Treat Road to Sand Hill Lane
8. **Tara Drive** – Hebron Avenue to Cavan Lane

SECTION 1.05 CONTROL OF WORK

Article 1.05.05 – Cooperation by Contractor

Add the following:

Agents of various public service agencies, municipal and State Departments, and private site contractors may be entering on the work site to remove existing utilities, to construct or place new facilities or to make alterations to existing facilities.

The Contractor shall perform the work in cooperation with the various agencies in a manner which causes the least interference with the operations of the aforementioned agencies and shall have no claim for delay which may be due to, or result from, said work of these agents.

Article 1.05.06 – Cooperation with Utilities

Add the following:

Written notice shall be given by the Contractor to all public service corporations or municipal and State Officials owning or having charge of publicly or privately-owned utilities 30 days in advance of the commencement of operations that will affect the utilities. The Contractor shall, at the same time, file a copy of such notice with the Engineer.

The utility company representatives listed in Section 1.07 shall be contacted by the Contractor to coordinate the protection of their utilities on this project 30 days prior to the start of any work on this project involving their utilities.

The Contractor shall make his/her own investigation to assure that no damage to existing structures, drainage lines, traffic signal conduits, and other utilities will occur as a result of construction operations. The Contractor shall notify "Call Before You Dig" at 1-800-922-4455, 72 hours prior to disturbing ground in any way.

SECTION 1.06 CONTROL OF MATERIALS

Article 1.06.01 - Source of Supply and Quality:

Add the following:

For the following items the contractor shall submit a complete description of the item, working drawings, catalog cuts and other descriptive literature which completely illustrates such items presented for formal approval. Such approval shall not change the requirements for a certified test report and materials certificate as may be called for. All shop drawings shall be submitted at one time, unless otherwise approved by the Engineer.

1. Temporary Pavement
2. Type "C" Catch Basin Top
3. Type "C" Catch Basin Top Double Grate Type 1
4. Type "C-L" Catch Basin Top
5. 15" R.C. Pipe
6. 24" R.C. Pipe

Article 1.07.07 – Safety and Public Convenience

Add the following:

The Contractor shall provide the necessary access for emergency vehicles through the work zones to abutting properties at all times.

Sweeping and cleaning of surfaces beyond the limits of construction required for dust control or to clean up material caused by spillage or vehicular tracking during various phases of the work shall be considered as incidental to the work being performed under the Contract and there will be no additional compensation.

The Contractor shall notify all public safety agencies at least 48 hours prior to beginning any construction operation which will provide less than a 12 foot travel lane along any project roadway.

Article 1.07.13 - Contractor's Responsibility for Adjacent Property, Facilities and Services

Supplemented as follows:

The Contractor, in constructing or installing facilities alongside or near sewers, drains, water or gas pipes, electric or telephone conduits, poles, sidewalks, walls, vaults, or other structures shall sustain them securely in place. The Contractor shall coordinate with the officers and agents of the various utility companies and municipal departments to assure that the services of these structures are maintained. The Contractor shall also be responsible for the repair or replacement, at no additional cost to the Town, of any damage to such structures caused by construction operations. The Contractor is responsible to leave them in the same condition as they existed prior to commencement of the work. In case of damage to utilities, the Contractor shall promptly notify the utility owner and shall, if requested by the Engineer, furnish labor and equipment to work temporarily under the utility owner's direction. Pipes or other structures damaged by the operation of the Contractor may be repaired by the utility owner which suffers the loss. The cost of such repairs shall be borne by the Contractor, without compensation from the Town.

If during construction there is an existing utility and/or structure found to be in conflict with the proposed work under this Contract, the Contractor shall protect and maintain the services to the utilities and structures and shall notify the Engineer of the conflict. The Engineer will, as soon as possible, identify the utilities to be relocated or other such activities deemed suitable for resolution.

If live service connections are to be interrupted by excavations of any kind, the Contractor shall not break the service until new services are provided. Abandoned services shall be plugged off or otherwise made secure.

Full compensation for furnishing all labor, materials, tools, equipment, and incidentals for doing all of the work involved in protecting or repairing property as specified in this Section shall be included in the price paid for the various Contract items of work, and no additional compensation will be allowed.

Prior to opening an excavation, effort shall be made to determine whether underground installations, (i.e. sewer, water, fuel, electric lines, etc.) will be encountered and, if so, where such underground installations are located. When the excavation approaches the estimated location of such an installation, the exact location shall be determined by careful probing or hand digging, and when it's uncovered, proper supports shall be provided for the existing installation. Utility companies shall be contacted and advised of proposed work prior to the start of actual excavation.

UTILITY COMPANIES WITHIN THE PROJECT AREA

The following company and representative shall be contacted by the Contractor to coordinate the protection of their utilities on this project 30 days prior to the start of any work on this project involving their utilities:

Connecticut Natural Gas Corporation, Engineering Department
Mr. Jonathan Gould,
Gas Engineer
76 Meadow Street, 2nd Floor
East Hartford, CT 06108
(860) 727-3044
jgould@ctgcorp.com

Algonquin Gas Transmission Company dba Enbridge
Mr. Kenneth Ruel,
Area Supervisor
252 Shunpike Road
Cromwell, CT 06416
Phone: (860) 894-1600 EXT: 1608
kenneth.ruel@enbridge.com

Frontier Communications
Ms. Lynne DeLucia,
Manager – Engineering & Construction
1441 North Colony Road
Meriden, CT 06450-4101
Phone: 203-238-5000
Mobile: 860-967-4389
Lynne.m.delucia@ftr.com

CoxCom, Inc.
Ms. Denise Mazzoli,
Project Planner
170 Utopia Road
Manchester, CT 06042
Phone: (860) 432-5041
denise.mazzoli@cox.com

Eversource Energy - Electric Distribution
Mr. Thomas Woronik
Supervisor - Construction Engineering
22 East High Street
East Hampton, CT 06424
Phone: (860) 267-3891
thomas.woronik@eversource.com

Lighttower Fiber Networks dba Crown Castle Fiber
Mr. Eric Clark,
Manager Fiber Construction
1781 Highland Avenue, Suite 102
Cheshire, CT 06410
Phone: (203) 649-3904
Mobile: 860-863-8311
Eric.clark@crowncastle.com

Metropolitan District Commission-(MDC)
Water Distribution
Mr. Richard Norris
Utility Coordinator/Project Manager
555 Main Street
P.O. Box 800
Hartford, CT. 06142
Phone: (860) 278-7850 Extension 3450
rnorris@themdc.com

Connecticut Natural Gas Corporation
Inspections
John Bonville
76 Meadow Street, 1st Floor
East Hartford, CT 06108
Phone: (860) 982-3815

TOWN OF GLASTONBURY

Engineering Division
2155 Main Street
Glastonbury, CT. 06033

Engineering Division
2155 Main Street
Glastonbury, CT. 06033

Glastonbury Police Department
2108 Main Street
Glastonbury, CT. 06033

Glastonbury Park & Recreation
2143 Main Street
Glastonbury, CT. 06033

Glastonbury Tree Warden
2143 Main Street
Glastonbury, CT. 06033

Glastonbury Highway Department
2380 New London Turnpike
Glastonbury, CT. 06033

Glastonbury Sanitation Department
2149 Main Street
Glastonbury, CT. 06033

Daniel A. Pennington, P.E.
Director of Physical Services/Town Engineer
Phone: (860) 652-7736
Email: Daniel.pennington@glastonbury-ct.gov

Stephen M. Braun, P.E.
Assistant Town Engineer
Phone: (860) 652-7743
Email: Stephen.braun@glastonbury-ct.gov

Watch Commander
Phone: (860) 633-8301

Lisa Zerio
Director of Parks & Recreation
Phone: (860) 652-7687
Email: lisa.zerio@glastonbury-ct.gov

Gregory Foran
Superintendent of Parks and Recreation/Tree
Warden
Phone: (860) 652-7686
Email: Gregory.foran@glastonbury-ct.gov

Charles Mahan
Physical Services Operations Manager
Phone: (860) 652-7750
Email: charles.mahan@glastonbury-ct.gov

Mike Manfre
Superintendent of Sanitation
Phone: (860) 652-7774
Email: mike.manfre@glastonbury-ct.gov

SECTION 1.08 PROSECUTION AND PROGRESS

Article 1.08.03 – Prosecution of Work

Add the following:

GENERAL: Before starting any work under this Contract, the Contractor shall prepare, and submit to the Engineer for approval, a minimum of 30 days in advance, a plan illustrating the Typical Traffic Management Plan for the roadway during construction. The Contractor will also be required to submit, and obtain approval from the Engineer, specific plans detailing the proposed Staging/Maintenance and Protection of Traffic Plans for the roadway in this Contract.

The Contractor must obtain approval of the Typical Traffic Management Plans and Staging/Maintenance and Protection of Traffic Plans from the Engineer prior to commencing work on the roadway.

All appropriate Maintenance and Protection of Traffic devices are to be installed prior to commencing construction operations.

Particular care shall be taken to establish and maintain methods and procedures that will not create unnecessary or unusual hazards to public safety. Traffic control devices required only during working hour operations shall be removed at the end of each working day.

Signs having messages that are irrelevant to normal traffic conditions shall be removed or properly covered at the end of each work period. Signs shall be kept clean at all times and legends shall be distinctive and unmarred.

The Contractor shall notify all public safety agencies at least 48 hours prior to beginning any construction operation which will provide less than a 12- foot travel lane along any project roadway.

ADVANCE NOTICE: The Contractor shall give the Engineer a seven-day advance written notice of construction activities that will alter traffic patterns that result in lane shifts, detours, temporary closures of lane(s), permanent closure of lane(s), or lane reductions. This advance notification will allow the Town to publish news releases and/or provide public radio announcements to inform the public of revised traffic patterns or possible traffic delays. Failure of the Contractor to provide such timely notice shall be considered a breach of Contract and will subject the Contractor to stop work orders until such time as the seven-day notice has been satisfied.

ALLOWABLE HOURS OF OPERATION (WORK PERIOD):

All work within this contract shall be performed Monday through Friday between the hours of 7:00AM and 5:00PM using appropriate shoulder closures or lane closure as deemed necessary for the work by the Engineer.

Work on weekends or during time periods other than those described above will not be permitted. No work will be allowed on designated Town Holidays unless permission is granted by the Town.

SEQUENCE OF CONSTRUCTION OPERATIONS: Work shall be sequenced as follows:

Contractor is required to confine their work area to a single street unless otherwise approved by the Engineer. Catch Basin rehabilitation work area shall be confined to a single lane in the same direction progressing up one side and down the other to complete one street at a time.

At the end of each day, the contractor is required to have each work area location completely stabilized for safe passage of traffic. This includes securing the new catch basin frame and grate to the structure and installation of full depth bituminous patch installed to grade. Overnight plating of any open excavation(s) will not be allowed.

Any open excavations left overnight related to the construction of concrete sidewalks and/or concrete sidewalk ramps shall have appropriate "Sidewalk Closed" signage installed at the limits along with the entire work area cordoned off with appropriate high visibility warning tape.

The Contractor shall ensure that suitable temporary access is provided to all residential and commercial driveways at all times as described in the Special Provision for Maintenance and Protection of Traffic.

Article 1.08.04 - Limitation of Operations - Add the following:

In order to provide for traffic operations as outlined in the Special Provision "Maintenance and Protection of Traffic," the Contractor will not be permitted to perform any work which will interfere with the described traffic operations on all project roadways as follows:

On the following State observed Legal Holidays:

New Year's Day
Good Friday, Easter*
Memorial Day
Independence Day
Labor Day
Thanksgiving Day**
Christmas Day

The following restrictions also apply:

On the day before and the day after any of the above Legal Holidays.

On the Friday, Saturday, and Sunday immediately preceding any of the above Holidays celebrated on a Monday.

On the Saturday, Sunday, and Monday immediately following any of the above Holidays celebrated on a Friday.

* From 6:00 a.m. the Thursday before the Holiday to 8:00 p.m. the Monday after the Holiday.

** From 6:00 a.m. the Wednesday before the Holiday to 8:00 p.m. the Monday after the Holiday.

ITEM # 0406002A TEMPORARY PAVEMENT

Description:

Work under this item shall be the installation of temporary pavement within the limits of trench excavation in the roadway as part of the required storm drainage replacement or where ordered by the Engineer.

Materials:

HMA Courses: Material for the surface course shall conform to the requirements of HMA S0.375", as per the requirements of Section 4.06 of the Standard Specifications Form 817.

Only if bituminous plants are closed and it is not possible to obtain hot mix asphalt may "cold patch" be used, with the approval of the Engineer.

Processed Stone Base: The material for this item shall be **crushed trap rock** conforming to the requirements of Article M.05.01 Processed Aggregate Base and Pavement of the Form 817, except that coarse aggregate shall be broken stone, and fine aggregate shall be stone sand, screenings, or a combination thereof. Gravel or reclaimed miscellaneous aggregate shall not be used.

Subbase: The requirements of Section M.02 Grading C Gravel shall apply except that reclaimed miscellaneous aggregate shall not be used.

Construction Methods:

Wherever sections of existing bituminous pavement are to be removed and new temporary pavement abutted, the Contractor shall make such removals to neat lines. At the line of delineation, the Contractor shall cut the bituminous pavement with a saw or asphalt cutting wheel so as to form a straight line where new pavement will be placed against old. Care shall be exercised in removing the existing pavement to avoid "break-backs" beyond the cut line.

Excavation shall consist of the removal and disposal of all excavated materials, the removal of which is necessary for the proper completion of the work, to a depth as required to make the temporary pavement repair as shown on the typical pavement repair detail or as directed by the Engineer.

No open excavations or partially completed patches shall be left open or uncompleted overnight.

Eighteen (18) inches of processed stone base shall be installed in 3 lifts of 6-inch depth and compacted as required to achieve 95% of maximum theoretical density.

Two (2) inches of HMA 0.375" shall be placed as the temporary pavement surface course in a single lift using approved methods and compacted to a minimum of 92% of the maximum theoretical specific gravity using power rollers or other mechanical methods to achieve satisfactory results.

Method of Measurement:

The work will be measured for payment by the accepted number of square yards of "Temporary Pavement", of the type specified, complete in place. Measurement limits shall be to the allowable trench repair width shown on the construction plans or as approved by the Engineer.

There will be no direct measurement for payment of saw cutting, excavation, disposal of surplus materials, subbase, processed stone base, compaction, or HMA. This work and material will be included in the unit price for "Temporary Pavement".

Basis of Payment:

The furnishing and installing of "Temporary Pavement" shall be paid for at the contract price per square yard. The unit price shall include saw cutting, excavation, disposal of surplus materials, subbase, processed stone base, compaction, and preparation of the HMA patch, in accordance with the specifications and as directed by the Engineer. Payment shall include all labor, materials, equipment, cleaning of pavement surface, material disposal and incidentals necessary to complete the work described.

<u>Item No.</u>	<u>Description</u>	<u>Unit</u>
0406002A	TEMPORARY PAVEMENT	S.Y.

ITEM # 0944000A FURNISHING AND PLACING TOPSOIL

Work under this item shall conform to the applicable provisions of Section 9.44 TOPSOIL of the Standard Specifications Form 818 amended as follows:

Basis of Payment:

This work will be measured for payment by the number of square yards of area on which the placing of the topsoil has been completed and the work accepted.

The limits of payment shall be to the slope limits as shown on the plans. In the absence of slope limits, the maximum area of measurement shall be the area extending two feet behind the sidewalk and the area between the sidewalk and edge of pavement. No payment shall be made outside of these limits unless the disturbance was directed or approved by the Engineer. No payment shall be made for areas disturbed for staging, storage of materials, or other area disturbed for the convenience of the Contractor.

This work will be paid for at the Contract unit price per square yard for "Furnishing and Placing Topsoil", which price shall include all materials, equipment, tools, labor, and work incidental thereto.

<u>Item No.</u>	<u>Description</u>	<u>Unit</u>
0944000A	FURNISHING AND PLACING TOPSOIL	S.Y.

ITEM # 0950005A TURF ESTABLISHMENT

Description:

The work included in this item shall consist of providing an accepted uniform stand of established perennial turf grasses by furnishing and placing fertilizer, seed, and mulch on all areas to be treated as shown on the plans or where designated by the Engineer.

Materials:

The materials for this work shall conform to the requirements of Section M.13 of the Form 818, except as noted below.

Seed mix for lawn areas shall consist of 30% Crest Kentucky Bluegrass, 30% Baron Kentucky Bluegrass, 20% Victory II Chewings Fescue, and 20% Perennial Rye Grass.

Seed mix for other roadside areas designated for turf establishment shall consist of 70% Red Fescue, 20% Kentucky Blue Grass, and 10% Perennial Rye Grass.

Erosion Control Matting shall be a product approved by the Connecticut Department of Transportation for the intended application as described in the "Qualified Products List" publication, latest edition.

Hydroseeding, when required by the Engineer, shall be performed using a homogenous slurry consisting of wood fiber mulch, fertilizer, live seed, and organic tackifiers conforming to Section M.13 of the Form 818.

Material certificates shall be provided for all materials supplied under this item.

Construction Methods:

Construction Methods shall be those established as agronomically acceptable and feasible and which are approved by the Engineer.

1. Preparation of the Seedbed:

(a) Level areas, medians, interchanges and lawns: These areas shall be made friable and receptive for seeding by disking or by other approved methods to the satisfaction of the Engineer. In all cases the final prepared and seeded soil surface shall meet the lines and grades for such surface as shown in the plans, or as directed by the Engineer.

(b) Slope and Embankment Areas: These areas shall be made friable and receptive to seeding by approved methods which will not disrupt the line and grade of the slope surface. In no event will seeding be permitted on hard or crusted soil surface.

(c) All areas to be seeded shall be reasonably free from weeds taller than 3 inches. Removal of weed growth from the slope areas shall be by approved methods, including hand-mowing, which do not rut or scar the slope surface, or cause excessive disruption of the slope line or grade. Seeding on level areas shall not be permitted until substantially all weed growth is removed. Seeding on slope areas shall not be permitted without removal or cutting of weed growth except by written permission of the Engineer.

2. Seeding Season: The calendar dates for seeding shall be:

Spring—March 15 to June 15

Fall—August 15 to October 15

All disturbed soil areas shall be treated during the seeding seasons as follows:

(a) Areas at final grade: Seeding will be accomplished.

(b) "Out-of-season" seedings shall be performed in the same manner as "in-season" seedings. Since acceptable turf establishment is less likely, the Contractor shall be responsible for "in-season" reseeding until the turf stand conforms to this specification.

(c) During "out-of-season" periods unseeded areas shall be treated in accordance with Section 2.10, Water Pollution Control.

3. Seeding Methods: The seed mixture shall be applied by any agronomically acceptable procedure. The rate of application shall be no less than 175 pounds per acre or according to manufacturer instructions. Fertilizer conforming to M.13.03 shall be initially applied at a rate of 320 pounds per acre during or preceding seeding. When wood fiber mulch is used, it shall be applied in a water slurry at a rate of 2,000 pounds per acre with or immediately after the application of seed, fertilizer and limestone.

When hydroseeding is required by the Engineer, it shall be performed by a qualified Contractor who has a minimum of three-year experience in the successful performance of this work and has been approved by the Engineer. Hydroseed mix shall be applied in a slurry consisting of wood fiber mulch, fertilizer, live seed, and organic tackifiers with each component applied at the rate described above. The slurry shall be hydraulically sprayed on the soil surface as required to form a blotter-like ground cover with a uniform coating. Contractor shall exercise special care as required to prevent slurry from being sprayed onto adjacent paved areas, sidewalks, buildings, or signs. All slurry sprayed onto adjacent surfaces shall be cleaned at the Contractor's expense.

When the grass seeding growth has attained a height of 6 inches, the specified areas designated herein shall be mowed to a height of 3 inches. Following mowing, all seeding grass areas (mowed and un-mowed) shall receive a uniform application of fertilizer hydraulically placed at the rate of 320 pounds per acre.

4. Compaction: The Contractor shall keep all equipment and vehicular and pedestrian traffic off areas that have been seeded to prevent excessive compaction and damage to young plants. Where such compaction has occurred, the Contractor shall rework the soil to make a suitable seedbed; then re-seed and mulch such areas with the full amounts of the specified materials, at no extra expense to the Town.

5. Stand of Perennial Turf Grasses: The Contractor shall provide and maintain a uniform stand of established turf grass or wetland vegetation having attained a height of 6 inches consisting of no less than 100 plants per square foot throughout the seeded areas until the entire project has been accepted.

6. Establishment: The Contractor shall keep all seeded areas free from weeds and debris, such as stones, cables, baling wire, and he shall mow at his own expense, on a one-time-only basis, all slopes 4:1 or less (flatter) and level turf established (seeded) areas to a height of 3 inches when the grass growth attains a height of 6 inches. Clean-up shall include, but not be limited to, the removal of all debris from the turf establishment operations on the shoulders, pavement, and/or elsewhere on adjacent properties publicly and privately owned.

7. Erosion Control Matting: Erosion control matting shall be installed following seeding where called for on the plans or as directed by the Engineer. Staples shall be installed as per Manufacturer's recommendations. Where two lengths of matting are joined, the end of the up-grade strip shall overlap the down-grade strip. The Contractor shall maintain and protect the areas with erosion control matting until such time as the turf grass is established. The Contractor shall replace or repair at his own expense any and all erosion control matting areas damaged by fire, water or other causes including the operation of construction equipment. No mowing will be required in the locations where erosion control matting is installed.

Method of Measurement:

This work will be measured for payment by the number of square yards of surface area of accepted established perennial turf grass or wetland vegetation as specified or by the number of square yards surface area of seeding actually covered and as specified.

Restoration of areas disturbed for staging, storage of materials, or other area disturbed for the convenience of the Contractor will not be measured for payment.

Basis of Payment:

This work will be paid for at the contract unit price per square yard for "Turf Establishment", which price shall include all materials, mowing, maintenance, equipment, tools, labor, and work incidental thereto. Partial payment of up to 60% may be made for work completed, but not accepted.

<u>Item No.</u>	<u>Description</u>	<u>Unit</u>
0950005A	TURF ESTABLISHMENT	S.Y.

ITEM # 0970007A TRAFFICPERSON (UNIFORMED FLAGGER)

Work under this item shall conform to the applicable provisions of Section 9.70 of the Standard Specifications Form 818 supplemented as follows:

Description: Add the following to the first paragraph of Section 9.70.01

“Trafficpersons shall consist of uniformed flaggers meeting acceptable criteria. The Contractor shall provide Uniformed Flaggers meeting the requirements of this specification as required for safe traffic operations in the project area. Extra-duty police officers will be used only when specifically required by the Police Chief, as the Local Traffic Authority, who will make this determination based on the Contractor’s proposed operations, traffic volumes, and traffic conditions.”

“All work under this item shall be paid only for the duration of the Contract as contained in the Special Conditions under ‘Time for Completion/Notice to Proceed’ and for any time extensions granted in writing by the Town. Payment for police officers required after the duration of the Contract and approved time extensions shall be made directly by the Town and such costs deducted from future payments due the Contractor.”

Basis of Payment: Replace Section 9.70.05 with the following:

“There will be no direct payment for safety garments or STOP/SLOW paddles. All costs associated with furnishing safety garments and STOP/SLOW paddles shall be considered included in the general cost of the item.

1. Trafficperson - Uniformed Flagger: Uniformed flaggers will be paid for at the contract unit price per hour for “Trafficperson (Uniformed Flagger)” as listed in the bid proposal, which price shall include all compensation, insurance benefits, and any other cost or liability incidental to the furnishing of the traffic persons ordered.”

<u>Item No.</u>	<u>Description</u>	<u>Unit</u>
0970007A	TRAFFICPERSON (UNIFORMED FLAGGER)	HOUR

ITEM # 0971001A MAINTENANCE AND PROTECTION OF TRAFFIC

Article 9.71.01 – Description is supplemented by the following:

The Contractor shall maintain and protect traffic as described by the following and as limited in the Special Provision "Prosecution and Progress":

The Town of Glastonbury CHIEF OF POLICE, acting in the capacity of the LOCAL TRAFFIC AUTHORITY, shall be the sole and final authority for the Maintenance and Protection of Traffic.

All Other Roadways

The Contractor shall maintain and protect a minimum of one lane of traffic in each direction, each lane on a travel path not less than 11 feet in width.

Excepted therefrom will be those periods, during the allowable periods, when the Contractor is actively working, at which time the Contractor shall maintain and protect at least an alternating one-way traffic operation, on a travel path not less than 11 feet in width. The length of the alternating one-way traffic operation shall not exceed 300 feet and there shall be no more than one alternating one-way traffic operation on Other Roadways within the project limits without prior approval of the Engineer.

Commercial and Residential Driveways

The Contractor shall maintain access to and egress from all commercial and residential driveways throughout the project limits. The Contractor will be allowed to close said driveways to perform the required work during those periods when the businesses are closed, unless permission is granted from the business owner to close the driveway during business hours. If a temporary closure of a residential driveway is necessary, the Contractor shall coordinate with the owner to determine the time period of the closure.

Article 9.71.03 - Construction Method is supplemented as follows:

General

The Contractor shall schedule operations such that all open excavations are backfilled or steel plated by the end of each active work period. The installation of steel plates shall be approved by the Town of Glastonbury Public Works Department prior to installation. Trenches and other excavations within the travel way that are backfilled shall be brought up to finished grade and paved with bituminous concrete pavement prior to reopening the roadway to vehicular traffic.

When the Contractor is excavating adjacent to the roadway, the Contractor shall provide a 3-foot shoulder between the work area and travel lanes, with traffic drums spaced every 20 feet. At the end of the workday, if the vertical drop-off exceeds 3 inches, the Contractor shall provide a temporary traversable slope of 4:1 or flatter that is acceptable to the Engineer.

The Contractor, during the course of active construction work on overhead signs and structures, shall close the lanes directly below the work area for the entire length of time overhead work is being undertaken. At no time shall an overhead sign be left partially removed or installed.

If applicable, when an existing sign is removed, it shall be either relocated or replaced by a new sign during the same working day.

The Contractor shall not store any material on-site which would present a safety hazard to motorists or pedestrians (e.g. fixed object or obstruct sight lines).

The field installation of a signing pattern shall constitute interference with existing traffic operations and shall not be allowed, except during the allowable periods.

Existing Signing

The Contractor shall maintain all existing overhead and side-mounted signs throughout the project limits during the duration of the project. The Contractor shall temporarily relocate signs and sign supports as many times as deemed necessary, and install temporary sign supports if necessary and as directed by the Engineer.

Signing Patterns

The Contractor shall provide such safety measures, pavement markings, traffic control devices, incidental flagmen, and signs deemed necessary to safeguard and guide the traveling public through the work zones as ordered by the Engineer, included in the approved maintenance scheme, or as shown on the plan. The Contractor shall erect, maintain, move, adjust, clean, relocate, store all signs, barricades, drums, traffic cones, and delineators when, where, and as directed by the Engineer. The use of unauthorized or unapproved signs, barricades, drums, traffic cones, or delineators will not be permitted.

All signs in any one signing pattern shall be mounted at the same height above the pavement. The Contractor shall keep all signs in proper position, clean and legible at all times. The Contractor shall maintain the site so that no weeds, shrubbery, construction materials, equipment or soil will obscure any sign, light, or barricade. Signs that no longer pertain to the project conditions shall be removed or adjusted from the view of traffic. Traffic drums shall be used in place of traffic cones in traffic control patterns that are in effect for more than a 72-hour duration. Traffic drums shall be used to delineate raised catch basins and other hazards.

Requirements for Winter

The Contractor shall schedule a meeting with representatives from the Town of Glastonbury to determine what interim traffic control measures the Contractor shall accomplish for the winter to provide safety to the motorists and permit adequate snow removal procedures. This meeting shall be held prior to October 31 of each year and will include, but not be limited to, discussion of the status and schedule of the following items: lane and shoulder widths, pavement restoration, traffic signal work, pavement markings, and signing.

Pavement Markings

During construction, the Contractor shall maintain all pavement markings on paved surfaces on all roadways throughout the limits of the project.

The Contractor should install painted pavement markings on the final course of bituminous concrete pavement by the end of the work day/night. If the painted pavement markings are not installed by the end of the work day/night, then Temporary Plastic Pavement Marking Tape shall be installed as described above and the painted pavement markings shall be installed by the end of the work day/night on Friday of that week.

If Temporary Plastic Pavement Marking Tape is installed, the Contractor shall remove and dispose of these markings when the painted pavement markings are installed. The cost of furnishing, installing and removing the Temporary Plastic Pavement Marking Tape shall be at the Contractor's expense.

NOTE: Painted pavement markings will not be allowed as a substitution for either the permanent pavement markings or the Temporary Plastic Pavement Marking Tape on the final course of bituminous concrete pavement.

Dust Control

The Contractor shall be responsible for taking all steps necessary to minimize dust emanating from the project and for keeping the street free of accumulations of sand or similar materials. When ordered by the Engineer, the Contractor shall remove snow and take care of ice on temporary, new and existing sidewalks within the limits of the project. No additional payment will be made for this work.

Pavement Markings -Non-Limited Access Multilane Roadways

Secondary and Local Roadways

During construction, the Contractor shall maintain all pavement markings on paved surfaces on all roadways throughout the limits of the project.

Interim Pavement Markings

The Contractor shall install painted pavement markings, which shall include centerlines, shoulder edge lines, lane lines (broken lines), lane-use arrows, and stop bars, on each intermediate course of bituminous concrete pavement and on any milled surface by the end of the work day/night. If the next course of bituminous concrete pavement will be placed within seven days, shoulder edge lines are not required. The painted pavement markings will be paid under the appropriate items.

If the Contractor will install another course of bituminous concrete pavement within 24 hours, the Contractor may install Temporary Plastic Pavement Marking Tape in place of the painted pavement markings by the end of the work day/night. These temporary pavement markings shall include centerlines, lane lines (broken lines) and stop bars; shoulder edge lines are not required. Centerlines shall consist of two 4 inch wide yellow markings, 2 feet in length, side by side, 4 to 6 inches apart, at 40-foot intervals. No passing zones should be posted with signs in those areas where the final centerlines have not been established on two-way roadways. Stop bars may consist of two 6 inch wide white markings or three 4 inch wide white markings placed side by side. The Contractor shall remove and dispose of the Temporary Plastic Pavement Marking Tape when another course of bituminous concrete pavement is installed. The cost of furnishing, installing and removing the Temporary Plastic Pavement Marking Tape shall be at the Contractor's expense.

If an intermediate course of bituminous concrete pavement will be exposed throughout the winter, then Epoxy Resin Pavement Markings should be installed unless directed otherwise by the Engineer.

Final Pavement Markings

The Contractor should install painted pavement markings on the final course of bituminous concrete pavement by the end of the work day/night. If the painted pavement markings are not installed by the end of the work day/night, then Temporary Plastic Pavement Marking Tape shall be installed as described above and the painted pavement markings shall be installed by the end of the work day/night on Friday of that week.

If Temporary Plastic Pavement Marking Tape is installed, the Contractor shall remove and dispose of these markings when the painted pavement markings are installed. The cost of furnishing, installing and removing the Temporary Plastic Pavement Marking Tape shall be at the Contractor's expense.

The Contractor shall install permanent Epoxy Resin Pavement Markings in accordance with Section 12.10 entitled "Epoxy Resin Pavement Markings, Symbols, and Legends" after such time as determined by the Engineer.

TRAFFIC CONTROL DURING CONSTRUCTION OPERATIONS

The following guidelines shall assist field personnel in determining when and what type of traffic control patterns to use for various situations. These guidelines shall provide for the safe and efficient movement of traffic through work zones and enhance the safety of work forces in the work area.

TRAFFIC CONTROL PATTERNS

Traffic control patterns shall be used when a work operation requires that all or part of any vehicle or work area protrudes onto any part of a travel lane or shoulder. For each situation, the installation of traffic control devices shall be based on the following:

- Speed and volume of traffic
- Duration of operation
- Exposure to hazards

Traffic control patterns shall be uniform, neat and orderly so as to command respect from the motorist.

In the case of a horizontal or vertical sight restriction in advance of the work area, the traffic control pattern shall be extended to provide adequate sight distance for approaching traffic.

If a lane reduction taper is required to shift traffic, the entire length of the taper should be installed on a tangent section of roadway so that the entire taper area can be seen by the motorist.

Any existing signs that are in conflict with the traffic control patterns shall be removed, covered, or turned so that they are not readable by oncoming traffic.

When installing a traffic control pattern, a Buffer Area should be provided and this area shall be free of equipment, workers, materials and parked vehicles.

Typical traffic control plans may be used for moving operations such as line striping, pot hole patching, mowing, or sweeping when it is necessary for equipment to occupy a travel lane.

Traffic control patterns will not be required when vehicles are on an emergency patrol type activity or when a short duration stop is made and the equipment can be contained within the shoulder. Flashing lights and appropriate trafficperson shall be used when required.

Although each situation must be dealt with individually, conformity with the typical traffic control plans contained herein is required. In a situation not adequately covered by the typical traffic control plans, the Contractor must contact the Engineer for assistance prior to setting up a traffic control pattern.

PLACEMENT OF SIGNS

Signs must be placed in such a position to allow motorists the opportunity to reduce their speed prior to the work area. Signs shall be installed on the same side of the roadway as the work area. On multi-lane divided highways, advance warning signs shall be installed on both sides of the highway. On directional roadways (on-ramps, off-ramps, one-way roads), where the sight distance to signs is restricted, these signs should be installed on both sides of the roadway.

ALLOWABLE ADJUSTMENT OF SIGNS AND DEVICES SHOWN ON THE TRAFFIC CONTROL PLANS

The traffic control plans contained herein show the location and spacing of signs and devices under ideal conditions. Signs and devices should be installed as shown on these plans whenever possible.

The proper application of the traffic control plans and installation of traffic control devices depends on actual field conditions.

Adjustments to the traffic control plans shall be made only at the direction of the Engineer to improve the visibility of the signs and devices and to better control traffic operations.

Adjustments to the traffic control plans shall be based on safety of work forces and motorists, abutting property requirements, driveways, side roads, and the vertical and horizontal curvature of the roadway.

The Engineer may require that the traffic control pattern be located significantly in advance of the work area to provide better sight line to the signing and safer traffic operations through the work zone.

Table I indicates the minimum taper length required for a lane closure based on the posted speed limit of the roadway. These taper lengths shall only be used when the recommended taper lengths shown on the traffic control plans cannot be achieved.

TABLE I – MINIMUM TAPER LENGTHS

POSTED SPEED LIMIT MILES PER HOUR	MINIMUM TAPER LENGTH IN FEET FOR A SINGLE LANE CLOSURE
30 OR LESS	180
35	250
40	320
45	540
50	600
55	660
65	780

SECTION 1. WORK ZONE SAFETY MEETINGS

- 1.a) Prior to the commencement of work, a work zone safety meeting will be conducted with representatives of the Engineer, Municipal Police, the Contractor (Project Superintendent) and the Traffic Control Subcontractor (if different than the prime Contractor) to review the traffic operations, lines of responsibility, and operating guidelines which will be used on the project. Other work zone safety meetings during the course of the project should be scheduled as needed.
- 1.b) A Work Zone Safety Meeting Agenda shall be developed and used at the meeting to outline the anticipated traffic control issues during the construction of this project. Any issues that can't be resolved at these meetings will be brought to the attention of the Engineer. The agenda should include:
- Review Project scope of work and time
 - Review Section 1.08, Prosecution and Progress
 - Review Section 9.70, Trafficpersons
 - Review Section 9.71, Maintenance and Protection of Traffic
 - Review Contractor's schedule and method of operations.
 - Review areas of special concern: ramps, turning roadways, medians, lane drops, etc.
 - Open discussion of work zone questions and issues
 - Discussion of review and approval process for changes in contract requirements as they relate to work zone areas

SECTION 2. GENERAL

- 2.a) If the required minimum number of signs and equipment (i.e. one High Mounted Internally Illuminated Flashing Arrow for each lane closed, two TMAs, Changeable Message Sign, etc.) are not available; the traffic control pattern shall not be installed.
- 2.b) The Contractor shall have back-up equipment (TMAs, High Mounted Internally Illuminated Flashing Arrow, Changeable Message Sign, construction signs, cones/drums, etc.) available at all times in case of mechanical failures, etc. The only exception to this is in the case of sudden equipment breakdowns in which the pattern may be installed but the Contractor must provide replacement equipment within 24 hours.
- 2.c) Failure of the Contractor to have the required minimum number of signs, personnel and equipment, which results in the pattern not being installed, shall not be a reason for a time extension or claim for loss time.
- 2.d) In cases of legitimate differences of opinion between the Contractor and the Inspection staff, the Inspection staff shall err on the side of safety. The matter shall be brought to the Engineer for resolution immediately or, in the case of work after regular business hours, on the next business day.

SECTION 3. INSTALLING AND REMOVING TRAFFIC CONTROL PATTERNS

- 3.a) Lane Closures shall be installed beginning with the advanced warning signs and proceeding forward toward the work area.

- 3.b) Lane Closures shall be removed in the reverse order, beginning at the work area, or end of the traffic control pattern, and proceeding back toward the advanced warning signs.
- 3.c) Stopping traffic may be allowed:
- As per the contract for such activities as blasting, steel erection, etc.
 - During paving, milling operations, etc. where, in the middle of the operation, it is necessary to flip the pattern to complete the operation on the other half of the roadway and traffic should not travel across the longitudinal joint or difference in roadway elevation.
 - To move slow moving equipment across live traffic lanes into the work area.
- 3.d) Under certain situations when the safety of the traveling public and/or that of the workers may be compromised due to conditions such as traffic volume, speed, roadside obstructions, or sight line deficiencies, as determined by the Engineer and/or State Police, traffic may be briefly impeded while installing and/or removing the advanced warning signs and the first ten traffic cones/drums only. Appropriate measures shall be taken to safely slow traffic. If required, traffic slowing techniques may be used and shall include the use of Truck Mounted Impact Attenuators (TMAs) as appropriate, for a minimum of one mile in advance of the pattern starting point. Once the advanced warning signs and the first ten traffic cones/drums are installed/removed, the TMAs and sign crew shall continue to install/remove the pattern as described in Section 4c and traffic shall be allowed to resume their normal travel.
- 3.e) The Contractor must adhere to using the proper signs, placing the signs correctly, and ensuring the proper spacing of signs.
- 3.f) Additional devices are required on entrance ramps, exit ramps, and intersecting roads to warn and/or move traffic into the proper travel path prior to merging/exiting with/from the main line traffic. This shall be completed before installing the mainline pattern past the ramp or intersecting roadway.
- 3.g) Prior to installing a pattern, any conflicting existing signs shall be covered with an opaque material. Once the pattern is removed, the existing signs shall be uncovered.
- 3.h) On limited access roadways, workers are prohibited from crossing the travel lanes to install and remove signs or other devices on the opposite side of the roadway. Any signs or devices on the opposite side of the roadway shall be installed and removed separately.

SECTION 6. USE OF TRAFFIC DRUMS AND TRAFFIC CONES

- 6.a) Traffic drums shall be used for taper channelization on limited-access roadways, ramps, and turning roadways and to delineate raised catch basins and other hazards.
- 6.b) Traffic drums shall be used in place of traffic cones in traffic control patterns that are in effect for more than a 36-hour duration.
- 6.c) Traffic Cones less than 42 inches in height shall not be used on limited-access roadways or on non-limited access roadways with a posted speed limit of 45 mph and above.
- 6.d) Typical spacing of traffic drums and/or cones shown on the Traffic Control Plans in the Contract are maximum spacings and may be reduced to meet actual field conditions as required.

SERIES 16 SIGNS

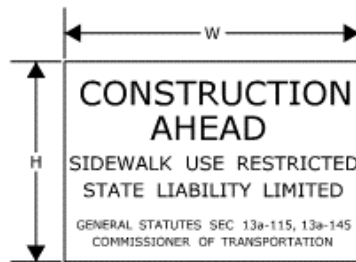
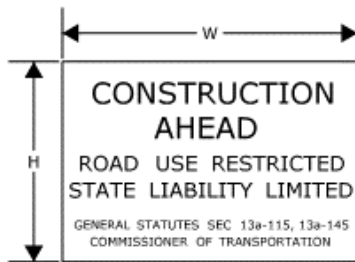

		W	H
16-E	80-1605	84" x 60"	
16-H	80-1608	60" x 42"	
16-M	80-1613	30" x 24"	

		W	H
16-S	80-1619	48" x 30"	

SIGN 16-S SHALL BE USED ON ALL PROJECTS THAT REQUIRE SIDEWALK RECONSTRUCTION OR RESTRICT PEDESTRIAN TRAVEL ON AN EXISTING SIDEWALK.

SERIES 16 SIGNS SHALL BE INSTALLED IN ADVANCE OF THE TRAFFIC CONTROL PATTERNS. SERIES 16 SIGNS SHOULD BE LOCATED TO ALLOW MOTORISTS THE OPPORTUNITY TO AVOID A WORK ZONE. SERIES 16 SIGNS SHOULD BE INSTALLED ON MAJOR INTERSECTING ROADWAYS THAT APPROACH THE WORK ZONE. ON LIMITED-ACCESS HIGHWAYS, THESE SIGNS SHOULD BE LOCATED IN ADVANCE OF THE NEAREST UPSTREAM EXIT RAMP AND ON ANY ENTRANCE RAMPS PRIOR TO OR WITHIN THE WORK ZONE LIMITS.

SIGNS 16-E AND 16-H SHALL BE POST-MOUNTED.

SIGN 16-E SHALL BE USED ON ALL FREEWAYS AND EXPRESSWAYS.

SIGN 16-H SHALL BE USED ON ALL RAMPS, OTHER STATE ROADWAYS AND MAJOR TOWN/CITY ROADWAYS.

SIGN 16-M SHALL BE USED ON OTHER TOWN ROADWAYS.

CONSTRUCTION TRAFFIC CONTROL PLAN
SERIES 16 SIGNS

SCALE: NONE

CONNECTICUT DEPARTMENT OF TRANSPORTATION
BUREAU OF ENGINEERING & CONSTRUCTION

APPROVED

Tracy L. Fogarty
PRINCIPAL ENGINEER

Tracy L. Fogarty, P.E.
2013.10.09 16:30:32-0402

REGULATORY SIGN "ROAD WORK AHEAD, FINES DOUBLED"

THE REGULATORY SIGN "ROAD WORK AHEAD FINES DOUBLED" SHALL BE INSTALLED FOR ALL WORK ZONES THAT OCCUR ON ANY STATE HIGHWAY AND MUNICIPAL ROAD IN CONNECTICUT WHERE THERE ARE WORKERS PRESENT ON THE HIGHWAY.

THE "ROAD WORK AHEAD FINES DOUBLED" REGULATORY SIGN SHALL BE PLACED AFTER THE SERIES 16 SIGN AND IN ADVANCE OF THE "ROAD WORK AHEAD" SIGN.

	W	H
31-1906	48"	42"
31-1907	60"	54"

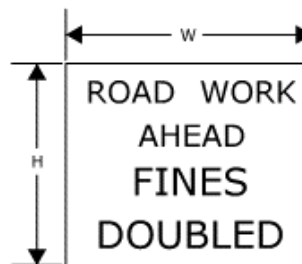

"END ROAD WORK" SIGN

THE LAST SIGN IN THE PATTERN SHALL BE THE "END ROAD WORK" SIGN.

	W	H
80-9606	36"	18"
80-9612	48"	24"

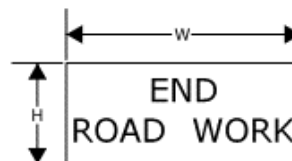

CONSTRUCTION TRAFFIC CONTROL PLAN
ROAD WORK AHEAD
SIGNS

SCALE: NONE

CONNECTICUT DEPARTMENT OF TRANSPORTATION
BUREAU OF ENGINEERING & CONSTRUCTION

APPROVED

Tracy L. Fogarty
PRINCIPAL ENGINEER

Tracy L. Fogarty, P.E.
2010.08.12 15:58:44 04/02

NOTES FOR TRAFFIC CONTROL PLANS

1. IF A TRAFFIC STOPPAGE OCCURS IN ADVANCE OF SIGN (A), THEN AN ADDITIONAL SIGN (A) SHALL BE INSTALLED IN ADVANCE OF THE STOPPAGE.
2. SIGNS (AA), (A), AND (D) SHOULD BE OMITTED WHEN THESE SIGNS HAVE ALREADY BEEN INSTALLED IN ADVANCE TO DESIGNATE A LARGER WORK ZONE THAN THE WORK ZONE THAT IS ENCOMPASSED ON THIS PLAN.
3. SEE TABLE 1 FOR ADJUSTMENT OF TAPERS IF NECESSARY.
4. TRAFFIC CONES AND PORTABLE CONSTRUCTION SIGNS SHALL NOT BE LEFT UNATTENDED.
5. ALL CONFLICTING SIGNS WITHIN THE LIMITS OF A ROADWAY / LANE CLOSURE AREA SHALL BE COVERED WITH AN OPAQUE MATERIAL WHILE THE CLOSURE IS IN EFFECT, AND UNCOVERED WHEN THE ROADWAY / LANE CLOSURE IS RE-OPENED TO ALL LANES OF TRAFFIC.
6. IF THIS PLAN REMAINS IN CONTINUOUS OPERATION FOR MORE THAN 48 HOURS, THEN ANY EXISTING CONFLICTING PAVEMENT MARKINGS SHALL BE ERADICATED OR COVERED, AND TEMPORARY PAVEMENT MARKINGS THAT DELINEATE THE PROPER TRAVELPATHS SHALL BE INSTALLED.
7. DISTANCES BETWEEN SIGNS IN THE ADVANCE WARNING AREA MAY BE REDUCED TO 100' ON LOW-SPEED URBAN ROADS (SPEED LIMIT \leq 40 MPH).
8. IF THIS PLAN IS TO REMAIN IN OPERATION FROM SUNSET TO SUNRISE, INSTALL BARRICADE WARNING LIGHTS - HIGH INTENSITY ON ALL POST-MOUNTED DIAMOND SIGNS IN THE ADVANCE WARNING AREA.
9. A PORTABLE CHANGEABLE MESSAGE SIGN SHALL BE INSTALLED ONE HALF MILE TO ONE MILE IN ADVANCE OF THE LANE CLOSURE TAPER.
10. SIGN (P) SHALL BE MOUNTED A MINIMUM OF 7 FEET FROM THE PAVEMENT SURFACE TO THE BOTTOM OF THE SIGN.

TABLE 1 - MINIMUM TAPER LENGTHS

POSTED SPEED LIMIT (MILES PER HOUR)	MINIMUM TAPER LENGTH FOR A SINGLE LANE CLOSURE
30 OR LESS	180'
35	245'
40	320'
45	540'
50	600'
55	660'
65	780'

CONSTRUCTION TRAFFIC CONTROL PLAN
NOTES

SCALE: NONE

CONNECTICUT DEPARTMENT OF TRANSPORTATION
BUREAU OF ENGINEERING & CONSTRUCTION

APPROVED

Tracy L. Fogarty
PRINCIPAL ENGINEER

Tracy L. Fogarty, P.E.
2019.05.13 08:47:47-04107

WORK IN TRAVEL LANE AND SHOULDER TWO LANE HIGHWAY ALTERNATING ONE-WAY TRAFFIC OPERATIONS

SIGN FACE
108 SQ. FT (MIN.)

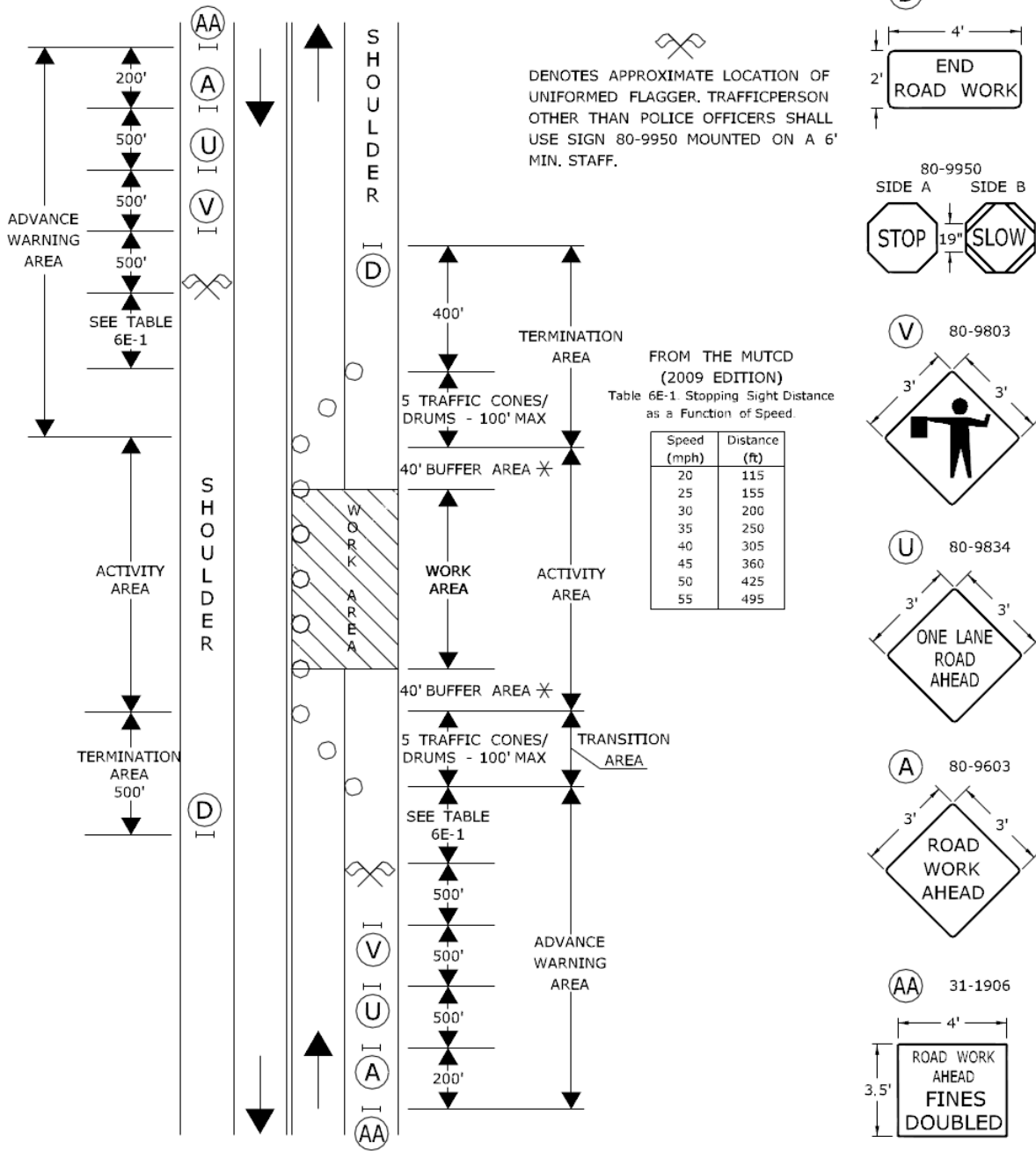

- TRAFFIC CONE **OR** TRAFFIC DRUM
- ✱ OPTIONAL ✕ TRAFFIC DRUM — PORTABLE SIGN SUPPORT
- ◀ HIGH MOUNTED INTERNALLY ILLUMINATED FLASHING ARROW



CONSTRUCTION TRAFFIC CONTROL PLAN
PLAN 13 - SHEET 1 OF 2
SEE NOTES 1, 2, 4, 6, 7, 8

CONNECTICUT DEPARTMENT OF TRANSPORTATION
BUREAU OF ENGINEERING & CONSTRUCTION

APPROVED *Charles S. Harlow* Charles S. Harlow
2012.06.05 15:55:23-04'00"
PRINCIPAL ENGINEER

WORK IN TRAVEL LANE AND SHOULDER TWO LANE HIGHWAY ALTERNATING ONE-WAY TRAFFIC OPERATIONS

SIGN FACE
108 SQ. FT (MIN.)

HAND SIGNAL METHODS TO BE USED BY UNIFORMED FLAGGERS

THE FOLLOWING METHODS FROM SECTION 6E.07, FLAGGER PROCEDURES, IN THE "MANUAL ON UNIFORM TRAFFIC CONTROL DEVICES," SHALL BE USED BY UNIFORMED FLAGGERS WHEN DIRECTING TRAFFIC THROUGH A WORK AREA. THE STOP/SLOW SIGN PADDLE (SIGN NO. 80-9950) SHOWN ON THE TRAFFIC STANDARD SHEET TR-1220 01 ENTITLED, "SIGNS FOR CONSTRUCTION AND PERMIT OPERATIONS" SHALL BE USED.

A. TO STOP TRAFFIC

TO STOP ROAD USERS, THE FLAGGER SHALL FACE ROAD USERS AND AIM THE STOP PADDLE FACE TOWARD ROAD USERS IN A STATIONARY POSITION WITH THE ARM EXTENDED HORIZONTALLY AWAY FROM THE BODY. THE FREE ARM SHALL BE HELD WITH THE PALM OF THE HAND ABOVE SHOULDER LEVEL TOWARD APPROACHING TRAFFIC.



B. TO DIRECT TRAFFIC TO PROCEED

TO DIRECT STOPPED ROAD USERS TO PROCEED, THE FLAGGER SHALL FACE ROAD USERS WITH THE SLOW PADDLE FACE AIMED TOWARD ROAD USERS IN A STATIONARY POSITION WITH THE ARM EXTENDED HORIZONTALLY AWAY FROM THE BODY. THE FLAGGER SHALL MOTION WITH THE FREE HAND FOR ROAD USERS TO PROCEED.



C. TO ALERT OR SLOW TRAFFIC

TO ALERT OR SLOW TRAFFIC, THE FLAGGER SHALL FACE ROAD USERS WITH THE SLOW PADDLE FACE AIMED TOWARD ROAD USERS IN A STATIONARY POSITION WITH THE ARM EXTENDED HORIZONTALLY AWAY FROM THE BODY. TO FURTHER ALERT OR SLOW TRAFFIC, THE FLAGGER HOLDING THE SLOW PADDLE FACE TOWARD ROAD USERS MAY MOTION UP AND DOWN WITH THE FREE HAND, PALM DOWN.



- TRAFFIC CONE **OR** TRAFFIC DRUM
- * OPTIONAL ⊗ TRAFFIC DRUM ⇨ PORTABLE SIGN SUPPORT
- ◀ HIGH MOUNTED INTERNALLY ILLUMINATED FLASHING ARROW



SCALE: NONE

CONSTRUCTION TRAFFIC CONTROL PLAN
PLAN 13 - SHEET 2 OF 2
SEE NOTES 1, 2, 4, 6, 7, 8

CONNECTICUT DEPARTMENT OF TRANSPORTATION
BUREAU OF ENGINEERING & CONSTRUCTION

APPROVED

Charles S. Harlow
PRINCIPAL ENGINEER

Charles S. Harlow
2012.06.05 15:55:45-04'00'

WORK IN SHOULDER - TWO LANE HIGHWAY

SIGN FACE
71 SQ. FT (MIN.)

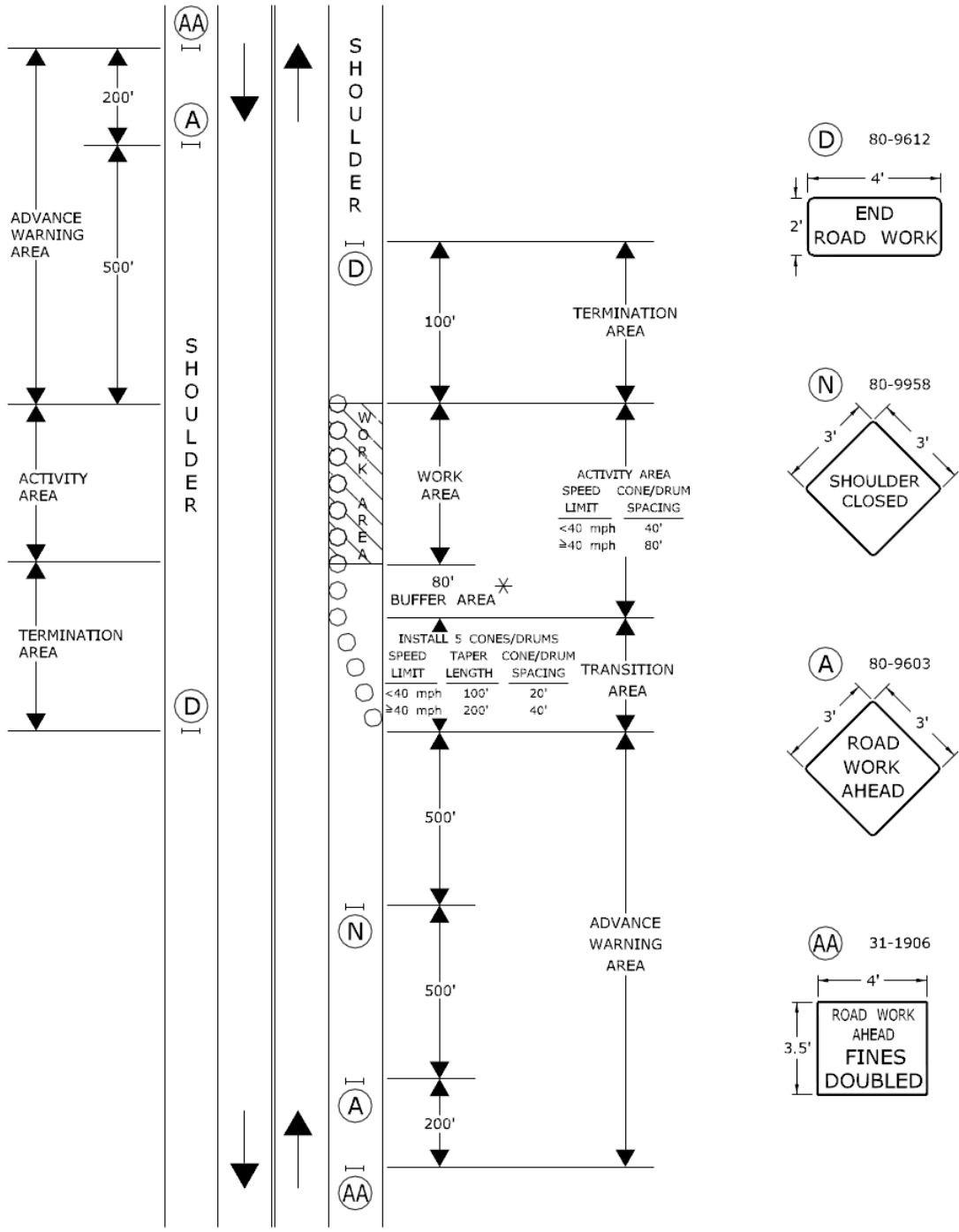

- TRAFFIC CONE **OR** TRAFFIC DRUM
- * OPTIONAL ⊗ TRAFFIC DRUM ⇄ PORTABLE SIGN SUPPORT
- ◀ HIGH MOUNTED INTERNALLY ILLUMINATED FLASHING ARROW



SCALE: NONE

CONSTRUCTION TRAFFIC CONTROL PLAN
PLAN 14
SEE NOTES 1, 2, 4, 7, 8

CONNECTICUT DEPARTMENT OF TRANSPORTATION
BUREAU OF ENGINEERING & CONSTRUCTION

APPROVED

Charles S. Harlow
Charles S. Harlow
2012.06.05 15:56:09-04'00"
PRINCIPAL ENGINEER

**WORK IN TRAVEL LANE AND SHOULDER
TWO LANE HIGHWAY
ALTERNATING ONE-WAY TRAFFIC OPERATIONS
STOP SIGN CONTROL**

SIGN FACE
125 SQ. FT (MIN.)

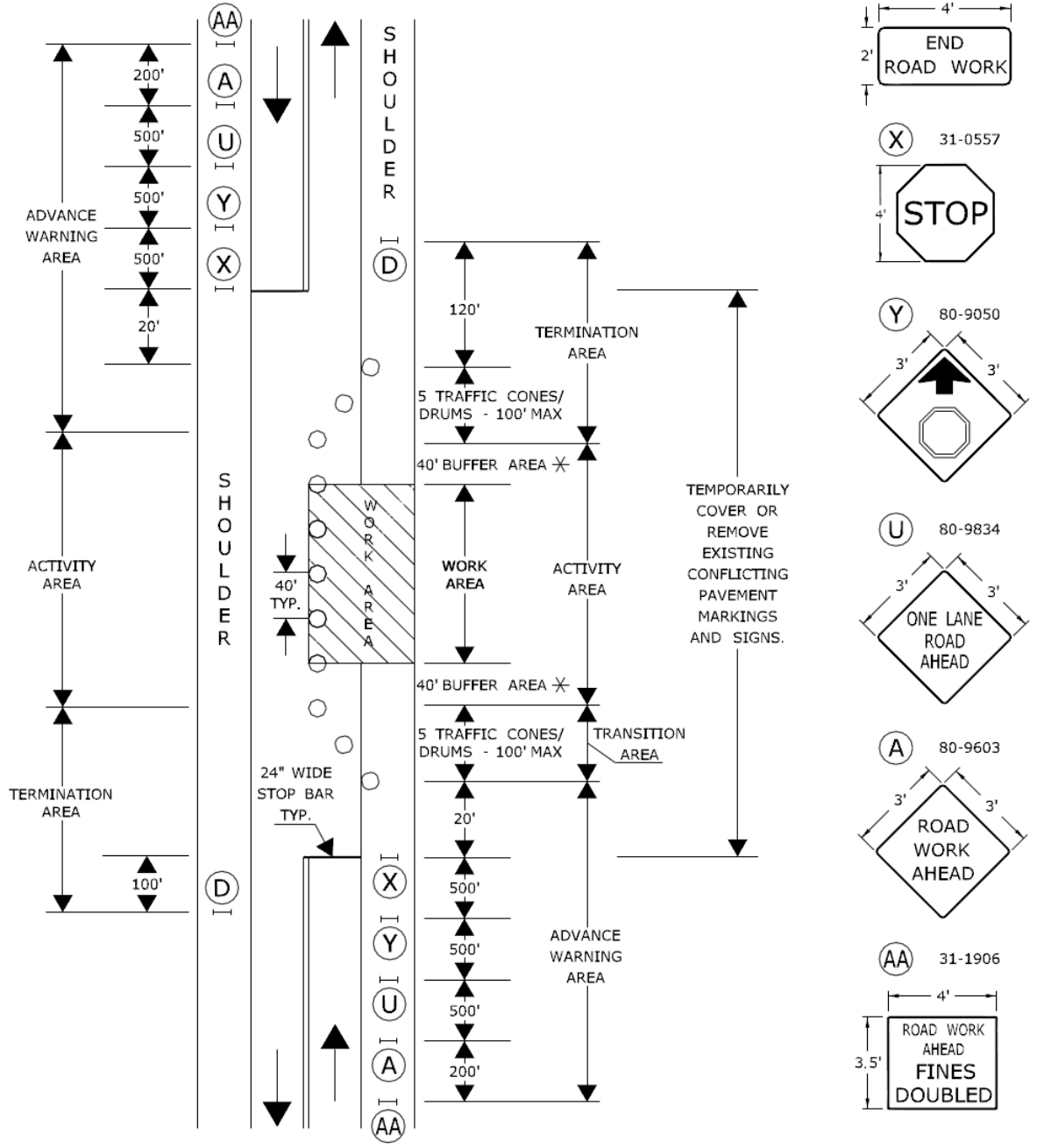

(D) 80-9612

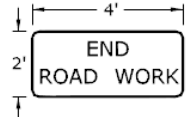

(X) 31-0557



(Y) 80-9050

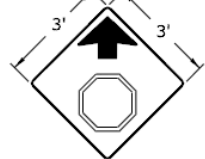

(U) 80-9834



(A) 80-9603



(AA) 31-1906

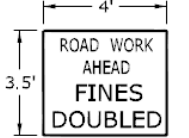

- TRAFFIC CONE OR TRAFFIC DRUM
- ✕ OPTIONAL ⊗ TRAFFIC DRUM — PORTABLE SIGN SUPPORT
- ◀ HIGH MOUNTED INTERNALLY ILLUMINATED FLASHING ARROW



CONSTRUCTION TRAFFIC CONTROL PLAN
PLAN 18
SEE NOTES 1, 2, 4, 7, 8

CONNECTICUT DEPARTMENT OF TRANSPORTATION
BUREAU OF ENGINEERING & CONSTRUCTION

APPROVED *Charles S. Harlow* Charles S. Harlow
PRINCIPAL ENGINEER 2012.06.05 15:57:37-0400'

Article 9.71.05 – Basis of Payment

When the item of "Maintenance and Protection of Traffic" appears in the contract, this work will be paid for at the contract lump sum price for "Maintenance and Protection of Traffic." This price shall include all material, equipment, tools, labor, transportation, operations and all work incidental thereto. The amount of the lump sum paid in any given period shall be proportional to the percentage of the total of all other work completed. All costs for labor, equipment and services involved in the erection, maintenance, moving, adjusting, cleaning, relocating and storing of signs, barricades, drums, traffic cones and delineators furnished by the Contractor as well as all costs of labor and equipment involved in the maintenance of traffic lanes and detours, except for pavement markings, ordered or included in the approved scheme for maintenance of traffic shall be included in the lump sum cost for this item.

Should the Contractor fail to perform any of the work required under this item, the Town may perform or arrange for others to perform such work. In those instances, the Town will deduct money due or money to become due to the contractor all expenses connected with the execution of this work. This money shall be deducted even if the Town expense exceeds the price bid for this work by the Contractor.

The contract lump sum price for "Maintenance and Protection of Traffic" shall also include temporarily relocating existing signs and sign supports as many times as deemed necessary and furnishing, installing, and removing temporary sign supports and foundations if necessary during construction of the project.

The contract lump sum price for "Maintenance and Protection of Traffic" shall also include the cost of all materials, tools, equipment and labor incidental thereto. No separate payments will be made for materials, excavation and disposal of materials, furnishing, placing, compacting the subbase, preparing the subgrade, or removal and disposal of the temporary bituminous curb and temporary walking paths and restoration of the disturbed areas.

**STORM DRAINAGE AND CATCH BASIN REHABILITATION
LOCATED ON VARIOUS TOWN ROADS**

BID #GL-2023-35

**ATTACHMENT A:
PREVAILING WAGE RATES**

**Minimum Rates and Classifications for
Heavy/Highway Construction**

ID#: 23-47947

**Connecticut Department of Labor
Wage and Workplace Standards Division**

By virtue of the authority vested in the Labor Commissioner under provisions of Section 31-53 of the General Statutes of Connecticut, as amended, the following are declared to be the prevailing rates and welfare payments and will apply only where the contract is advertised for bid within 20 days of the date on which the rates are established. Any contractor or subcontractor not obligated by agreement to pay to the welfare and pension fund shall pay this amount to each employee as part of his/her hourly wages.

Project Number: Project Town: Glastonbury
State#: FAP#:
Project: Storm Drainage and Catch Basin Rehabilitation

CLASSIFICATION	Hourly Rate	Benefits
1) Boilermaker	44.46	28.51
1a) Bricklayer, Cement Masons, Cement Finishers, Plasterers, Stone Masons	39.92	34.47
2) Carpenters, Piledrivermen	36.07	26.15
2a) Diver Tenders	36.07	26.15
3) Divers	44.53	26.15
03a) Millwrights	37.02	27.66
4) Painters: (Bridge Construction) Brush, Roller, Blasting (Sand, Water, etc.), Spray	55.0	23.75
4a) Painters: Brush and Roller	37.22	23.40
4b) Painters: Spray Only	40.22	23.40

4c) Painters: Steel Only	39.22	23.40
4d) Painters: Blast and Spray	40.22	23.40
4e) Painters: Tanks, Tower and Swing	39.22	23.40
4f) Elevated Tanks (60 feet and above)	46.22	23.40
5) Electrician (Trade License required: E-1,2 L-5,6 C-5,6 T-1,2 L-1,2 V-1,2,7,8,9)	41.75	31.47+3% of gross wage
6) Ironworkers: Ornamental, Reinforcing, Structural, and Precast Concrete Erection	39.7	38.77 + a
7) Plumbers (Trade License required: (P-1,2,6,7,8,9 J-1,2,3,4 SP-1,2) and Pipefitters (Including HVAC Work) (Trade License required: S-1,2,3,4,5,6,7,8 B-1,2,3,4 D-1,2,3,4 G-1, G-2, G-8, G-9)	47.03	34.05
----LABORERS----		
8) Group 1: General Laborers and concrete specialist	33.5	25.59
8) Group 1a: Acetylene Burners (Hours worked with a torch)	34.5	25.59
9) Group 2: Chain saw operators, fence and guard rail erectors, pneumatic tool operators, powdermen	33.75	25.59
10) Group 3: Pipelayers	34.0	25.59
11) Group 4: Jackhammer/Pavement breaker (handheld); mason tenders (cement/concrete), catch basin builders, asphalt rakers, air track operators, block paver, curb setter and forklift operators	34.0	25.59

As of: May 8, 2023

12) Group 5: Toxic waste removal (non-mechanical systems)	35.5	25.59
13) Group 6: Blasters	35.25	25.59
Group 7: Asbestos/lead removal, non-mechanical systems (does not include leaded joint pipe)	36.5	25.59
Group 8: Traffic control signalmen	20.1	25.59
Group 9: Hydraulic Drills	34.25	25.59
Group 10: Toxic Waste Removers A or B With PPE	36.5	25.59
----LABORERS (TUNNEL CONSTRUCTION, FREE AIR). Shield Drive and Liner Plate Tunnels in Free Air.----		
13a) Miners, Motormen, Mucking Machine Operators, Nozzle Men, Grout Men, Shaft & Tunnel Steel & Rodmen, Shield & Erector, Arm Operator, Cable Tenders	35.73	25.59 + a
13b) Brakemen, Trackmen, Miners' Helpers and all other men	34.76	25.59 + a
----CLEANING, CONCRETE AND CAULKING TUNNEL----		
14) Concrete Workers, Form Movers, and Strippers	34.76	25.59 + a
15) Form Erectors	35.09	25.59 + a
----ROCK SHAFT LINING, CONCRETE, LINING OF SAME AND TUNNEL IN FREE AIR:----		
16) Brakemen, Trackmen, Tunnel Laborers, Shaft Laborers, Miners Helpers	34.76	25.59 + a

As of: May 8, 2023

17) Laborers Topside, Cage Tenders, Bellman	34.65	25.59 + a
18) Miners	35.73	25.59 + a
----TUNNELS, CAISSON AND CYLINDER WORK IN COMPRESSED AIR: ----		
18a) Blaster	42.22	25.59 + a
19) Brakemen, Trackmen, Groutman, Laborers, Outside Lock Tender, Gauge Tenders	42.02	25.59 + a
20) Change House Attendants, Powder Watchmen, Top on Iron Bolts	40.04	25.59 + a
21) Mucking Machine Operator, Grout Boss, Track Boss	42.81	25.59 + a
----TRUCK DRIVERS----(*see note below)		
Two Axle Trucks, Helpers	32.16	30.51 + a
Three Axle Trucks; Two Axle Ready Mix	32.27	30.51 + a
Three Axle Ready Mix	32.33	30.51 + a
Four Axle Trucks	32.39	30.51 + a
Four Axle Ready-Mix	32.44	30.51 + a
Heavy Duty Trailer (40 tons and over)	34.66	30.51 + a

As of: May 8, 2023

Specialized earth moving equipment other than conventional type on-the road trucks and semi-trailer (including Euclids)	32.44	30.51 + a
Heavy Duty Trailer (up to 40 tons)	33.39	30.51 + a
Snorkle Truck	32.54	30.51 + a
----POWER EQUIPMENT OPERATORS----		
Group 1: Crane Handling or Erecting Structural Steel or Stone, Hoisting Engineer (2 drums or over). (Trade License Required)	52.78	27.80 + a
Group 1a: Front End Loader (7 cubic yards or over); Work Boat 26 ft. and over.	48.37	27.80 + a
Group 2: Cranes (100 ton rate capacity and over); Bauer Drill/Caisson. (Trade License Required)	52.41	27.80 + a
Group 2a: Cranes (under 100 ton rated capacity).	51.51	27.80 + a
Group 2b: Excavator over 2 cubic yards; Pile Driver (\$3.00 premium when operator controls hammer).	48.0	27.80 + a
Group 3: Excavator; Gradall; Master Mechanic; Hoisting Engineer (all types of equipment where a drum and cable are used to hoist or drag material regardless of motive power of operation), Rubber Tire Excavator (Drott-1085 or similar); Grader Operator; Bulldozer Fine Grade (slopes, shaping, laser or GPS, etc.). (Trade License Required)	47.1	27.80 + a
Group 4: Trenching Machines; Lighter Derrick; CMI Machine or Similar; Koehring Loader (Skooper).	46.64	27.80 + a
Group 5: Specialty Railroad Equipment; Asphalt Paver; Asphalt Spreader; Asphalt Reclaiming Machine; Line Grinder; Concrete Pumps; Drills with Self Contained Power Units; Boring Machine; Post Hole Digger; Auger; Pounder; Well Digger; Milling Machine (over 24" mandrel)	45.92	27.80 + a

Group 5 continued: Side Boom; Combination Hoe and Loader; Directional Driller.	45.92	27.80 + a
Group 6: Front End Loader (3 up to 7 cubic yards); Bulldozer (rough grade dozer).	45.55	27.80 + a
Group 7: Asphalt Roller; Concrete Saws and Cutters (ride on types); Vermeer Concrete Cutter; Stump Grinder; Scraper; Snooper; Skidder; Milling Machine (24" and under Mandrel)	45.14	27.80 + a
Group 8: Mechanic, Grease Truck Operator, Hydroblaster, Barrier Mover, Power Stone Spreader; Welder; Work Boat under 26 ft.; Transfer Machine.	44.67	27.80 + a
Group 9: Front End Loader (under 3 cubic yards), Skid Steer Loader regardless of attachments (Bobcat or Similar); Fork Lift, Power Chipper; Landscape Equipment (including hydroseeder), Vacuum Excavation Truck and Hydrovac Excavation Truck (27 HG pressure or greater).	44.14	27.80 + a
Group 10: Vibratory Hammer, Ice Machine, Diesel and Air Hammer, etc.	41.69	27.80 + a
Group 11: Conveyor, Earth Roller; Power Pavement Breaker (whiphammer), Robot Demolition Equipment.	41.69	27.80 + a
Group 12: Wellpoint Operator.	41.61	27.80 + a
Group 13: Compressor Battery Operator.	40.92	27.80 + a
Group 14: Elevator Operator; Tow Motor Operator (Solid Tire No Rough Terrain).	39.54	27.80 + a
Group 15: Generator Operator; Compressor Operator; Pump Operator; Welding Machine Operator; Heater Operator.	39.06	27.80 + a
Group 16: Maintenance Engineer.	38.28	27.80 + a

As of: May 8, 2023

Group 17: Portable Asphalt Plant Operator; Portable Crusher Plant Operator; Portable Concrete Plant Operator., Portable Grout Plant Operator, Portable Water Filtration Plant Operator.	43.46	27.80 + a
---	-------	-----------

Group 18: Power Safety Boat; Vacuum Truck; Zim Mixer; Sweeper; (minimum for any job requiring CDL license).	40.54	27.80 + a
---	-------	-----------

****NOTE: SEE BELOW**

----LINE CONSTRUCTION----(Railroad Construction and Maintenance)----

20) Lineman, Cable Splicer, Technician	48.19	6.5% + 22.00
--	-------	--------------

21) Heavy Equipment Operator	42.26	6.5% + 19.88
------------------------------	-------	--------------

22) Equipment Operator, Tractor Trailer Driver, Material Men	40.96	6.5% + 19.21
--	-------	--------------

23) Driver Groundmen	26.5	6.5% + 9.00
----------------------	------	-------------

23a) Truck Driver	40.96	6.5% + 17.76
-------------------	-------	--------------

----LINE CONSTRUCTION----

24) Driver Groundmen	30.92	6.5% + 9.70
----------------------	-------	-------------

25) Groundmen	22.67	6.5% + 6.20
---------------	-------	-------------

26) Heavy Equipment Operators	37.1	6.5% + 10.70
-------------------------------	------	--------------

27) Linemen, Cable Splicers, Dynamite Men	41.22	6.5% + 12.20
---	-------	--------------

As of: May 8, 2023

28) Material Men, Tractor Trailer Drivers, Equipment Operators

35.04 6.5% + 10.45

Welders: Rate for craft to which welding is incidental.

**Note: Hazardous waste removal work receives additional \$1.25 per hour for truck drivers.*

***Note: Hazardous waste premium \$3.00 per hour over classified rate*

Crane with 150 ft. boom (including jib) - \$1.50 extra

Crane with 200 ft. boom (including jib) - \$2.50 extra

Crane with 250 ft. boom (including jib) - \$5.00 extra

Crane with 300 ft. boom (including jib) - \$7.00 extra

Crane with 400 ft. boom (including jib) - \$10.00 extra

All classifications that indicate a percentage of the fringe benefits must be calculated at the percentage rate times the "base hourly rate".

Apprentices duly registered under the Commissioner of Labor's regulations on "Work Training Standards for Apprenticeship and Training Programs" Section 31-51-d-1 to 12, are allowed to be paid the appropriate percentage of the prevailing journeymen hourly base and the full fringe benefit rate, providing the work site ratio shall not be less than one full-time journeyman instructing and supervising the work of each apprentice in a specific trade.

--Connecticut General Statute Section 31-55a: Annual Adjustments to wage rates by contractors doing state work
--

The Prevailing wage rates applicable to this project are subject to annual adjustments each July 1st for the duration of the project.

Each contractor shall pay the annual adjusted prevailing wage rate that is in effect each July 1st, as posted by the Department of Labor.

It is the contractor's responsibility to obtain the annual adjusted prevailing wage rate increases directly from the Department of Labor's website.

The annual adjustments will be posted on the Department of Labor's Web page:

www.ct.gov/dol. For those without internet access, please contact the division listed below.

The Department of Labor will continue to issue the initial prevailing wage rate schedule to the Contracting Agency for the project.

All subsequent annual adjustments will be posted on our Web Site for contractor access.

Contracting Agencies are under no obligation pursuant to State labor law to pay any increase due to the annual adjustment provision.

Effective October 1, 2005 - Public Act 05-50: any person performing the work of any mechanic, laborer, or worker shall be paid prevailing wage

All Person who perform work ON SITE must be paid prevailing wage for the appropriate mechanic, laborer, or worker classification.

All certified payrolls must list the hours worked and wages paid to All Persons who perform work ON SITE regardless of their ownership i.e.: (Owners, Corporate Officers, LLC Members, Independent Contractors, et. al)

Reporting and payment of wages is required regardless of any contractual relationship alleged to exist between the contractor and such person.

As of: May 8, 2023

--Unlisted classifications needed for work not included within the scope of the classifications listed may be added after award only as provided in the labor standards contract clause (29 CFR 5.5 (a) (1) (ii)).

Please direct any questions which you may have pertaining to classification of work and payment of prevailing wages to the Wage and Workplace Standards Division, telephone (860)263-6790.

Important Information:

For use with Building, Heavy/Highway, and Residential

Welders: Rate for craft to which welding is incidental.

*Note: Hazardous waste removal work receives additional \$1.25 per hour for truck drivers.

**Note: Hazardous waste premium \$3.00 per hour over classified rate.

ALL Cranes: When crane operator is operating equipment that requires a fully licensed crane operator to operate he receives an extra \$4.00 premium in addition to the hourly wage rate and benefit contributions:

- 1) Crane handling or erecting structural steel or stone; hoisting engineer (2 drums or over)
- 2) Cranes (100 ton rate capacity and over) Bauer Drill/Caisson
- 3) Cranes (under 100 ton rated capacity)

Crane with boom including jib, 150 feet - \$1.50 extra.

Crane with boom including jib, 200 feet - \$2.50 extra.

Crane with boom including jib, 250 feet - \$5.00 extra.

Crane with boom including jib, 300 feet - \$7.00 extra.

Crane with boom including jib, 400 feet - \$10.00 extra.

All classifications that indicate a percentage of the fringe benefits must be calculated at the percentage rate times the "base hourly rate".

- Apprentices duly registered under the Commissioner of Labor's regulations on "Work Training Standards for Apprenticeship and Training Programs" Section 31-51-d-1 to 12, are allowed to be paid the appropriate percentage of the prevailing journeymen hourly base and the full fringe benefit rate, providing the work site ratio shall not be less than one full-time journeyman instructing and supervising the work of one apprentice in a specific trade.

Connecticut General Statute Section 31-55a: Annual Adjustments to wage rates by contractors doing state work

- The Prevailing wage rates applicable to this project are subject to annual adjustments each July 1st for the duration of the project.
- Each contractor shall pay the annual adjusted prevailing wage rate that is in effect each July 1st, as posted by the Department of Labor.
- It is the contractor's responsibility to obtain the annual adjusted prevailing wage rate increases directly from the Department of Labor's website.
- The annual adjustments will be posted on the Department of Labor's Web page: www.ctdol.state.ct.us.
- The Department of Labor will continue to issue the initial prevailing wage rate schedule to the Contracting Agency for the project.
- All subsequent annual adjustments will be posted on our Web Site for contractor access.

Effective October 1, 2005 - Public Act 05-50: any person performing the work of any mechanic, laborer, or worker shall be paid prevailing wage.

- All Persons who perform work ON SITE must be paid prevailing wage for the appropriate mechanic, laborer, or worker classification.
- All certified payrolls must list the hours worked and wages paid to All Persons who perform work ON SITE regardless of their ownership i.e.: (Owners, Corporate Officers, LLC Members, Independent Contractors, et. al)
- Reporting and payment of wages is required regardless of any contractual relationship alleged to exist between the contractor and such person.

Unlisted classifications needed for work not included within the scope of the classifications listed may be added after award only as provided in the labor standards contract clause (29 CFR 5.5 (a) (1) (ii)).

Please direct any questions which you may have pertaining to classification of work and payment of prevailing wages to the Wage and Workplace Standards Division, telephone (860)263-6790.

~NOTICE~

TO ALL CONTRACTING AGENCIES

Please be advised that Connecticut General Statutes Section 31-53, requires the contracting agency to certify to the Department of Labor, the total dollar amount of work to be done in connection with such public works project, regardless of whether such project consists of one or more contracts.

Please find the attached “Contracting Agency Certification Form” to be completed and returned to the Department of Labor, Wage and Workplace Standards Division, Public Contract Compliance Unit.

 Inquiries can be directed to (860)263-6543.

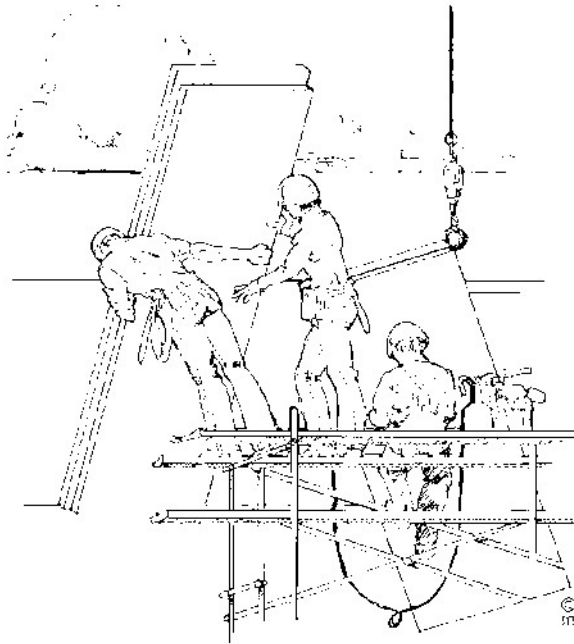

CONNECTICUT DEPARTMENT OF LABOR
WAGE AND WORKPLACE STANDARDS DIVISION
CONTRACT COMPLIANCE UNIT

CONTRACTING AGENCY CERTIFICATION FORM

I, _____, acting in my official capacity as _____,
authorized representative title

for _____, located at _____,
contracting agency address

do hereby certify that the total dollar amount of work to be done in connection with
_____, located at _____,
project name and number address

shall be \$_____, which includes all work, regardless of whether such project
consists of one or more contracts.

CONTRACTOR INFORMATION

Name: _____

Address: _____

Authorized Representative: _____

Approximate Starting Date: _____

Approximate Completion Date: _____

Signature

Date

Return To: Connecticut Department of Labor
Wage & Workplace Standards Division
Contract Compliance Unit
200 Folly Brook Blvd.
Wethersfield, CT 06109

Date Issued: _____

**Connecticut Department of Labor
Wage and Workplace Standards Division
FOOTNOTES**

⇒ Please Note: If the “Benefits” listed on the schedule for the following occupations includes a letter(s) (+ a or + a+b for instance), refer to the information below.

Benefits to be paid at the appropriate prevailing wage rate for the listed occupation.

If the “Benefits” section for the occupation lists only a dollar amount, disregard the information below.

Bricklayers, Cement Masons, Cement Finishers, Concrete Finishers, Stone Masons
(Building Construction) and
(Residential- Hartford, Middlesex, New Haven, New London and Tolland Counties)

- a. Paid Holiday: Employees shall receive 4 hours for Christmas Eve holiday provided the employee works the regularly scheduled day before and after the holiday. Employers may schedule work on Christmas Eve and employees shall receive pay for actual hours worked in addition to holiday pay.

Elevator Constructors: Mechanics

- a. Paid Holidays: New Year’s Day, Memorial Day, Independence Day, Labor Day, Veterans’ Day, Thanksgiving Day, Christmas Day, plus the Friday after Thanksgiving.
- b. Vacation: Employer contributes 8% of basic hourly rate for 5 years or more of service or 6% of basic hourly rate for 6 months to 5 years of service as vacation pay credit.

Glaziers

- a. Paid Holidays: Labor Day and Christmas Day.

Power Equipment Operators
(Heavy and Highway Construction & Building Construction)

- a. Paid Holidays: New Year’s Day, Good Friday, Memorial day, Independence Day, Labor Day, Thanksgiving Day and Christmas Day, provided the employee works 3 days during the week in which the holiday falls, if scheduled, and if scheduled, the working day before and the working day after the holiday. Holidays falling on Saturday may be observed on Saturday, or if the employer so elects, on the preceding Friday.

Ironworkers

- a. Paid Holiday: Labor Day provided employee has been on the payroll for the 5 consecutive work days prior to Labor Day.

Laborers (Tunnel Construction)

- a. Paid Holidays: New Year's Day, Memorial Day, Independence Day, Labor Day, Thanksgiving Day and Christmas Day. No employee shall be eligible for holiday pay when he fails, without cause, to work the regular work day preceding the holiday or the regular work day following the holiday.

Roofers

- a. Paid Holidays: July 4th, Labor Day, and Christmas Day provided the employee is employed 15 days prior to the holiday.

Sprinkler Fitters

- a. Paid Holidays: Memorial Day, July 4th, Labor Day, Thanksgiving Day and Christmas Day, provided the employee has been in the employment of a contractor 20 working days prior to any such paid holiday.

Truck Drivers

(Heavy and Highway Construction & Building Construction)

- a. Paid Holidays: New Year's Day, Memorial Day, Independence Day, Labor Day, Thanksgiving Day, Christmas day, and Good Friday, provided the employee has at least 31 calendar days of service and works the last scheduled day before and the first scheduled day after the holiday, unless excused.

Informational Bulletin

THE 10-HOUR OSHA CONSTRUCTION SAFETY AND HEALTH COURSE

(applicable to public building contracts entered into *on or after July 1, 2007*, where the total cost of all work to be performed is at least \$100,000)

- (1) This requirement was created by Public Act No. 06-175, which is codified in Section 31-53b of the Connecticut General Statutes (pertaining to the prevailing wage statutes);
- (2) The course is required for public building construction contracts (projects funded in whole or in part by the state or any political subdivision of the state) entered into on or after July 1, 2007;
- (3) It is required of private employees (not state or municipal employees) and apprentices who perform manual labor for a general contractor or subcontractor on a public building project where the total cost of all work to be performed is at least \$100,000;
- (4) The ten-hour construction course pertains to the ten-hour Outreach Course conducted in accordance with federal OSHA Training Institute standards, and, for telecommunications workers, a ten-hour training course conducted in accordance with federal OSHA standard, 29 CFR 1910.268;
- (5) The internet website for the federal OSHA Training Institute is http://www.osha.gov/fso/ote/training/edcenters/fact_sheet.html;
- (6) The statutory language leaves it to the contractor and its employees to determine who pays for the cost of the ten-hour Outreach Course;
- (7) Within 30 days of receiving a contract award, a general contractor must furnish proof to the Labor Commissioner that all employees and apprentices performing manual labor on the project will have completed such a course;
- (8) Proof of completion may be demonstrated through either: (a) the presentation of a *bona fide* student course completion card issued by the federal OSHA Training Institute; *or* (2) the presentation of documentation provided to an employee by a trainer certified by the Institute pending the actual issuance of the completion card;
- (9) Any card with an issuance date more than 5 years prior to the commencement date of the construction project shall not constitute proof of compliance;

- (10) Each employer shall affix a copy of the construction safety course completion card to the certified payroll submitted to the contracting agency in accordance with Conn. Gen. Stat. § 31-53(f) on which such employee's name first appears;
- (11) Any employee found to be in non-compliance shall be subject to removal from the worksite if such employee does not provide satisfactory proof of course completion to the Labor Commissioner by the fifteenth day after the date the employee is determined to be in noncompliance;
- (12) Any such employee who is determined to be in noncompliance may continue to work on a public building construction project for a maximum of fourteen consecutive calendar days while bringing his or her status into compliance;
- (13) The Labor Commissioner may make complaint to the prosecuting authorities regarding any employer or agent of the employer, or officer or agent of the corporation who files a false certified payroll with respect to the status of an employee who is performing manual labor on a public building construction project;
- (14) The statute provides the minimum standards required for the completion of a safety course by manual laborers on public construction contracts; any contractor can exceed these minimum requirements; and
- (15) Regulations clarifying the statute are currently in the regulatory process, and shall be posted on the CTDOL website as soon as they are adopted in final form.
- (16) Any questions regarding this statute may be directed to the Wage and Workplace Standards Division of the Connecticut Labor Department via the internet website of <http://www.ctdol.state.ct.us/wgwkstnd/wgemenu.htm>; or by telephone at (860)263-6790.

THE ABOVE INFORMATION IS PROVIDED EXCLUSIVELY AS AN EDUCATIONAL RESOURCE, AND IS NOT INTENDED AS A SUBSTITUTE FOR LEGAL INTERPRETATIONS WHICH MAY ULTIMATELY ARISE CONCERNING THE CONSTRUCTION OF THE STATUTE OR THE REGULATIONS.

November 29, 2006

Notice
To All Mason Contractors and Interested Parties
Regarding Construction Pursuant to Section 31-53 of the
Connecticut General Statutes (Prevailing Wage)

The Connecticut Labor Department Wage and Workplace Standards Division is empowered to enforce the prevailing wage rates on projects covered by the above referenced statute.

Over the past few years the Division has withheld enforcement of the rate in effect for workers who operate a forklift on a prevailing wage rate project due to a potential jurisdictional dispute.

The rate listed in the schedules and in our Occupational Bulletin (see enclosed) has been as follows:

Forklift Operator:

- **Laborers (Group 4) Mason Tenders** - operates forklift solely to assist a mason to a maximum height of nine feet only.
- **Power Equipment Operator (Group 9)** - operates forklift to assist any trade and to assist a mason to a height over nine feet.

The U.S. Labor Department conducted a survey of rates in Connecticut but it has not been published and the rate in effect remains as outlined in the above Occupational Bulletin.

Since this is a classification matter and not one of jurisdiction, effective January 1, 2007 the Connecticut Labor Department will enforce the rate on each schedule in accordance with our statutory authority.

Your cooperation in filing appropriate and accurate certified payrolls is appreciated.

Information Bulletin ***Occupational Classifications***

The Connecticut Department of Labor has the responsibility to properly determine "job classification" on prevailing wage projects covered under C.G.S. Section 31-53(d).

Note: This information is intended to provide a sample of some occupational classifications for guidance purposes only. It is not an all-inclusive list of each occupation's duties. This list is being provided only to highlight some areas where a contractor may be unclear regarding the proper classification. If unsure, the employer should seek guidelines for CTDOL.

Below are additional clarifications of specific job duties performed for certain classifications:

- **ASBESTOS WORKERS**

Applies all insulating materials, protective coverings, coatings and finishes to all types of mechanical systems.

- **ASBESTOS INSULATOR**

Handle, install apply, fabricate, distribute, prepare, alter, repair, dismantle, heat and frost insulation, including penetration and fire stopping work on all penetration fire stop systems.

- **BOILERMAKERS**

Erects hydro plants, incomplete vessels, steel stacks, storage tanks for water, fuel, etc. Builds incomplete boilers, repairs heat exchanges and steam generators.

- **BRICKLAYERS, CEMENT MASONS, CEMENT FINISHERS, MARBLE MASONS, PLASTERERS, STONE MASONS, PLASTERERS. STONE MASONS, TERRAZZO WORKERS, TILE SETTERS**

Lays building materials such as brick, structural tile and concrete cinder, glass, gypsum, terra cotta block. Cuts, tools and sets marble, sets stone, finishes concrete, applies decorative steel, aluminum and plastic tile, applies cements, sand, pigment and marble chips to floors, stairways, etc.

- **CARPENTERS, MILLWRIGHTS. PILEDRIVERMEN. LATHERS. RESILEINT FLOOR LAYERS, DOCK BUILDERS, DIKERS, DIVER TENDERS**

Constructs, erects, installs and repairs structures and fixtures of wood, plywood and wallboard. Installs, assembles, dismantles, moves industrial machinery. Drives piling into ground to provide foundations for structures such as buildings and bridges, retaining walls for earth embankments, such as cofferdams. Fastens wooden, metal or rockboard lath to walls, ceilings and partitions of buildings, acoustical tile layer, concrete form builder. Applies firestopping materials on fire resistive joint systems only. Installation of curtain/window walls only where attached to wood or metal studs. Installation of insulated material of all types whether blown, nailed or attached in other ways to walls, ceilings and floors of buildings. Assembly and installation of modular furniture/furniture systems. Free-standing furniture is not covered. This includes free standing: student chairs, study top desks, book box desks, computer furniture, dictionary stand, atlas stand, wood shelving, two-position information access station, file cabinets, storage cabinets, tables, etc.

- **LABORER, CLEANING**

- The clean up of any construction debris and the general (heavy/light) cleaning, including sweeping, wash down, mopping, wiping of the construction facility and its furniture, washing, polishing, and dusting.

- **DELIVERY PERSONNEL**

- If delivery of supplies/building materials is to one common point and stockpiled there, prevailing wages are not required. If the delivery personnel are involved in the distribution of the material to multiple locations within the construction site then they would have to be paid prevailing wages for the type of work performed: laborer, equipment operator, electrician, ironworker, plumber, etc.

- An example of this would be where delivery of drywall is made to a building and the delivery personnel distribute the drywall from one "stockpile" location to further sub-locations on each floor. Distribution of material around a construction site is the job of a laborer or tradesman, and not a delivery personnel.

- **ELECTRICIANS**

Install, erect, maintenance, alteration or repair of any wire, cable, conduit, etc., which generates, transforms, transmits or uses electrical energy for light, heat, power or other purposes, including the Installation or maintenance of telecommunication, LAN wiring or computer equipment, and low voltage wiring. ****License required per Connecticut General Statutes: E-1,2 L-5,6 C-5,6 T-1,2 L-1,2 V-1,2,7,8,9.***

- **ELEVATOR CONSTRUCTORS**

Install, erect, maintenance and repair of all types of elevators, escalators, dumb waiters and moving walks. **License required by Connecticut General Statutes: R-1,2,5,6.*

- **FORK LIFT OPERATOR**

Laborers Group 4) Mason Tenders - operates forklift solely to assist a mason to a maximum height of nine (9) feet only.

Power Equipment Operator Group 9 - operates forklift to assist any trade, and to assist a mason to a height over nine (9) feet.

- **GLAZIERS**

Glazing wood and metal sash, doors, partitions, and 2 story aluminum storefronts. Installs glass windows, skylights, store fronts and display cases or surfaces such as building fronts, interior walls, ceilings and table tops and metal store fronts. Installation of aluminum window walls and curtain walls is the "joint" work of glaziers and ironworkers, which require equal composite workforce.

- **IRONWORKERS**

Erection, installation and placement of structural steel, precast concrete, miscellaneous iron, ornamental iron, metal curtain wall, rigging and reinforcing steel. Handling, sorting, and installation of reinforcing steel (rebar). Metal bridge rail (traffic), metal bridge handrail, and decorative security fence installation. Installation of aluminum window walls and curtain walls is the "joint" work of glaziers and ironworkers which require equal composite workforce.

- **INSULATOR**

- Installing fire stopping systems/materials for "Penetration Firestop Systems": transit to cables, electrical conduits, insulated pipes, sprinkler pipe penetrations, ductwork behind radiation, electrical cable trays, fire rated pipe penetrations, natural polypropylene, HVAC ducts, plumbing bare metal, telephone and communication wires, and boiler room ceilings.

- **LABORERS**

Acetylene burners, asphalt rakers, chain saw operators, concrete and power buggy operator, concrete saw operator, fence and guard rail erector (except metal bridge rail (traffic), decorative security fence (non-metal).

installation.), hand operated concrete vibrator operator, mason tenders, pipelayers (installation of storm drainage or sewage lines on the street only), pneumatic drill operator, pneumatic gas and electric drill operator, powermen and wagon drill operator, air track operator, block paver, curb setters, blasters, concrete spreaders.

- **PAINTERS**

Maintenance, preparation, cleaning, blasting (water and sand, etc.), painting or application of any protective coatings of every description on all bridges and appurtenances of highways, roadways, and railroads. Painting, decorating, hardwood finishing, paper hanging, sign writing, scenic art work and drywall hhg for any and all types of building and residential work.

- **LEAD PAINT REMOVAL**

- Painter's Rate

1. Removal of lead paint from bridges.
2. Removal of lead paint as preparation of any surface to be repainted.
3. Where removal is on a Demolition project prior to reconstruction.

- Laborer's Rate

1. Removal of lead paint from any surface NOT to be repainted.
2. Where removal is on a *TOTAL* Demolition project only.

- **PLUMBERS AND PIPEFITTERS**

Installation, repair, replacement, alteration or maintenance of all plumbing, heating, cooling and piping. ****License required per Connecticut General Statutes: P-1,2,6,7,8,9 J-1,2,3,4 SP-1,2 S-1,2,3,4,5,6,7,8 B-1,2,3,4 D-1,2,3,4.***

- **POWER EQUIPMENT OPERATORS**

Operates several types of power construction equipment such as compressors, pumps, hoists, derricks, cranes, shovels, tractors, scrapers or motor graders, etc. Repairs and maintains equipment. ****License required, crane operators only, per Connecticut General Statutes.***

- **ROOFERS**

Covers roofs with composition shingles or sheets, wood shingles, slate or asphalt and gravel to waterproof roofs, including preparation of surface. (demolition or removal of any type of roofing and or clean-up of any and all areas where a roof is to be relaid.)

- **SHEETMETAL WORKERS**

Fabricate, assembles, installs and repairs sheetmetal products and equipment in such areas as ventilation, air-conditioning, warm air heating, restaurant equipment, architectural sheet metal work, sheetmetal roofing, and aluminum gutters. Fabrication, handling, assembling, erecting, altering, repairing, etc. of coated metal material panels and composite metal material panels when used on building exteriors and interiors as soffits, fascia, louvers, partitions, canopies, cornice, column covers, awnings, beam covers, cladding, sun shades, lighting troughs, spires, ornamental roofing, metal ceilings, mansards, copings, ornamental and ventilation hoods, vertical and horizontal siding panels, trim, etc. The sheet metal classification also applies to the vast variety of coated metal material panels and composite metal material panels that have evolved over the years as an alternative to conventional ferrous and non-ferrous metals like steel, iron, tin, copper, brass, bronze, aluminum, etc. Fabrication, handling, assembling, erecting, altering, repairing, etc. of architectural metal roof, standing seam roof, composite metal roof, metal and composite bathroom/toilet partitions, aluminum gutters, metal and composite lockers and shelving, kitchen equipment, and walk-in coolers. To include testing and air –balancing ancillary to installation and construction.

- **SPRINKLER FITTERS**

Installation, alteration, maintenance and repair of fire protection sprinkler systems.

****License required per Connecticut General Statutes: F-1,2,3,4.***

- **TILE MARBLE AND TERRAZZO FINISHERS**

Assists and tends the tile setter, marble mason and terrazzo worker in the performance of their duties.

- **TRUCK DRIVERS**

~How to pay truck drivers delivering asphalt is under REVISION~

Truck Drivers are requires to be paid prevailing wage for time spent "working" directly on the site. These drivers remain covered by the prevailing wage for any time spent transporting between the actual construction location and facilities (such as fabrication, plants, mobile factories, batch plant, borrow pits, job headquarters, tool yards, etc.) dedicated exclusively, or nearly so, to performance of the contract or project, which are so located in proximity to the actual construction location that it is reasonable to include them. ****License required, drivers only, per Connecticut General Statutes.***

For example:

- Material men and deliverymen are not covered under prevailing wage as long as they are not directly involved in the construction process. If, they unload the material, they would then be covered by prevailing wage for the classification they are performing work in: laborer, equipment operator, etc.
- Hauling material off site is not covered provided they are not dumping it at a location outlined above.
- Driving a truck on site and moving equipment or materials on site would be considered covered work, as this is part of the construction process.

➤ *Any questions regarding the proper classification should be directed to:*
Public Contract Compliance Unit
Wage and Workplace Standards Division
Connecticut Department of Labor
200 Folly Brook Blvd, Wethersfield, CT 06109
(860) 263-6790.

[New] In accordance with Section 31-53b(a) of the C.G.S. each contractor shall provide a copy of the OSHA 10 Hour Construction Safety and Health Card for each employee, to be attached to the first certified payroll on the project.

In accordance with Connecticut General Statutes, 31-53 Certified Payrolls with a statement of compliance shall be submitted monthly to the contracting agency.											PAYROLL CERTIFICATION FOR PUBLIC WORKS PROJECTS										Connecticut Department of Labor Wage and Workplace Standards Division 200 Folly Brook Blvd. Wethersfield, CT 06109				
CONTRACTOR NAME AND ADDRESS:											SUBCONTRACTOR NAME & ADDRESS						WORKER'S COMPENSATION INSURANCE CARRIER								
PAYROLL NUMBER		Week-Ending Date		PROJECT NAME & ADDRESS							Total ST Hours		BASE HOURLY RATE		TYPE OF FRINGE BENEFITS Per Hour 1 through 6 (see back)		GROSS PAY FOR ALL WORK PERFORMED THIS WEEK		TOTAL DEDUCTIONS				GROSS PAY FOR THIS PREVAILING RATE JOB		CHECK # AND NET PAY
PERSON/WORKER, ADDRESS and SECTION	APPR RATE %	MALE/FEMALE AND RACE*	WORK CLASSIFICATION	DAY AND DATE						Total O/T Hours	TOTAL FRINGE BENEFIT PLAN CASH	FICA	FEDERAL WITH-HOLDING	STATE WITH-HOLDING	LIST OTHER	GROSS PAY FOR THIS PREVAILING RATE JOB	CHECK # AND NET PAY								
				S	M	T	W	TH	F									S	HOURS WORKED EACH DAY						
Trade License Type & Number - OSHA 10 Certification Number																									

12/9/2013 *IF REQUIRED
WWS-CPI

*SEE REVERSE SIDE

PAGE NUMBER ____ OF

***FRINGE BENEFITS EXPLANATION (P):**

Bona fide benefits paid to approved plans, funds or programs, except those required by Federal or State Law (unemployment tax, worker’s compensation, income taxes, etc.).

Please specify the type of benefits provided:

- 1) Medical or hospital care _____ 4) Disability _____
- 2) Pension or retirement _____ 5) Vacation, holiday _____
- 3) Life Insurance _____ 6) Other (please specify) _____

CERTIFIED STATEMENT OF COMPLIANCE

For the week ending date of _____,

I, _____ of _____, (hereafter known as Employer) in my capacity as _____ (title) do hereby certify and state:

Section A:

1. All persons employed on said project have been paid the full weekly wages earned by them during the week in accordance with Connecticut General Statutes, section 31-53, as amended. Further, I hereby certify and state the following:

- a) The records submitted are true and accurate;
- b) The rate of wages paid to each mechanic, laborer or workman and the amount of payment or contributions paid or payable on behalf of each such person to any employee welfare fund, as defined in Connecticut General Statutes, section 31-53 (h), are not less than the prevailing rate of wages and the amount of payment or contributions paid or payable on behalf of each such person to any employee welfare fund, as determined by the Labor Commissioner pursuant to subsection Connecticut General Statutes, section 31-53 (d), and said wages and benefits are not less than those which may also be required by contract;
- c) The Employer has complied with all of the provisions in Connecticut General Statutes, section 31-53 (and Section 31-54 if applicable for state highway construction);
- d) Each such person is covered by a worker’s compensation insurance policy for the duration of his employment which proof of coverage has been provided to the contracting agency;
- e) The Employer does not receive kickbacks, which means any money, fee, commission, credit, gift, gratuity, thing of value, or compensation of any kind which is provided directly or indirectly, to any prime contractor, prime contractor employee, subcontractor, or subcontractor employee for the purpose of improperly obtaining or rewarding favorable treatment in connection with a prime contract or in connection with a prime contractor in connection with a subcontractor relating to a prime contractor; and
- f) The Employer is aware that filing a certified payroll which he knows to be false is a class D felony for which the employer may be fined up to five thousand dollars, imprisoned for up to five years or both.

2. OSHA~The employer shall affix a copy of the construction safety course, program or training completion document to the certified payroll required to be submitted to the contracting agency for this project on which such persons name first appears.

_____ Submitted on (Date)

(Signature) (Title)

Sec. 31-53b. Construction safety and health course. New miner training program. Proof of completion required for mechanics, laborers and workers on public works projects. Enforcement. Regulations. Exceptions. (a) Each contract for a public works project entered into on or after July 1, 2009, by the state or any of its agents, or by any political subdivision of the state or any of its agents, described in subsection (g) of section 31-53, shall contain a provision requiring that each contractor furnish proof with the weekly certified payroll form for the first week each employee begins work on such project that any person performing the work of a mechanic, laborer or worker pursuant to the classifications of labor under section 31-53 on such public works project, pursuant to such contract, has completed a course of at least ten hours in duration in construction safety and health approved by the federal Occupational Safety and Health Administration or, has completed a new miner training program approved by the Federal Mine Safety and Health Administration in accordance with 30 CFR 48 or, in the case of telecommunications employees, has completed at least ten hours of training in accordance with 29 CFR 1910.268.

(b) Any person required to complete a course or program under subsection (a) of this section who has not completed the course or program shall be subject to removal from the worksite if the person does not provide documentation of having completed such course or program by the fifteenth day after the date the person is found to be in noncompliance. The Labor Commissioner or said commissioner's designee shall enforce this section.

(c) Not later than January 1, 2009, the Labor Commissioner shall adopt regulations, in accordance with the provisions of chapter 54, to implement the provisions of subsections (a) and (b) of this section. Such regulations shall require that the ten-hour construction safety and health courses required under subsection (a) of this section be conducted in accordance with federal Occupational Safety and Health Administration Training Institute standards, or in accordance with Federal Mine Safety and Health Administration Standards or in accordance with 29 CFR 1910.268, as appropriate. The Labor Commissioner shall accept as sufficient proof of compliance with the provisions of subsection (a) or (b) of this section a student course completion card issued by the federal Occupational Safety and Health Administration Training Institute, or such other proof of compliance said commissioner deems appropriate, dated no earlier than five years before the commencement date of such public works project.

(d) This section shall not apply to employees of public service companies, as defined in section 16-1, or drivers of commercial motor vehicles driving the vehicle on the public works project and delivering or picking up cargo from public works projects provided they perform no labor relating to the project other than the loading and unloading of their cargo.

(P.A. 06-175, S. 1; P.A. 08-83, S. 1.)

History: P.A. 08-83 amended Subsec. (a) by making provisions applicable to public works project contracts entered into on or after July 1, 2009, replacing provision re total cost of work with reference to Sec. 31-53(g), requiring proof in certified payroll form that new mechanic, laborer or worker has completed a 10-hour or more construction safety course and adding provision re new miner training program, amended Subsec. (b) by substituting "person" for "employee" and adding "or program", amended Subsec. (c) by adding "or in accordance with Federal Mine Safety and Health Administration Standards" and setting new deadline of January 1, 2009, deleted former Subsec. (d) re "public building", added new Subsec. (d) re exemptions for public service company employees and delivery drivers who perform no labor other than delivery and made conforming and technical changes, effective January 1, 2009.