

OSQ Series

OSQ™ High Output LED Area/Flood Luminaire featuring Cree TrueWhite® Technology

Product Description

The OSQ™ High Output Area/Flood luminaire blends extreme optical control, advanced thermal management and modern, clean aesthetics. Built to last, the housing is rugged cast aluminum with an integral, weathertight LED driver compartment. Versatile mounting configurations offer simple installation. Its slim, low-profile design minimizes wind load requirements and blends seamlessly into the site providing even, quality illumination. The OSQ high output luminaire is a suitable upgrade for HID applications with one or even multiple 1000 Watt luminaires.

Applications: Auto dealerships, parking lots, campuses, facade lighting, high-mast and general site lighting applications

Performance Summary

Utilizes Cree TrueWhite® Technology on 5000K Luminaires

NanoOptic® Precision Delivery Grid™ optic

Assembled in the U.S.A. of U.S. and imported parts

Initial Delivered Lumens: Up to 68,691

Efficacy: Up to 125 LPW

CRI: Minimum 70 CRI (3000K, 4000K & 5700K); 90 CRI (5000K)

CCT: 3000K (+/- 300K), 4000K (+/- 300K), 5000K (+/- 300K), 5700K (+/- 500K)

Limited Warranty*: 10 years on luminaire/10 years on Colorfast DeltaGuard® finish

* See <http://lighting.cree.com/warranty> for warranty terms

Accessories

Field-Installed		
Backlight Shield (One pair) OSQ-HO-BLSF - Front Facing Optics OSQ-HO-BLSR - Rotated Optics	Bird Spikes OSQ-HO-BRDSPK	Hand-Held Remote XA-SENSREM - For successful implementation of the programmable multi-level option, a minimum of one hand-held remote is required

Ordering Information

Fully assembled luminaire is composed of two components that must be ordered separately:

Example: **Mount:** OSQ-HO-AA-SV + **Luminaire:** OSQ-HO-A-NM-2ME-40L-40K-UL-SV

Mount (Luminaire must be ordered separately)	
OSQ-HO-	
OSQ-HO-AA Adjustable Arm OSQ-HO-DA Direct Arm	Color Options: SV Silver BK Black BZ Bronze WH White

Luminaire (Mount must be ordered separately)									
OSQ-HO	A	NM	Optic		Lumen Package**	CCT	Voltage	Color Options	Options
OSQ-HO	A	NM No Mount	Asymmetric 2ME* Type II Medium 3ME* Type III Medium Symmetric 5ME Type V Medium 5SH Type V Short 15D 15° Flood 25D 25° Flood	4ME* Type IV Medium AF* Automotive FrontlineOptic™ 40D 40° Flood 60D 60° Flood 120D 120° Flood WSN Wide Sign	40L 50L 65L	30K 3000K - 70 CRI 40K 4000K - 70 CRI 50K 5000K - 90 CRI 57K 5700K - 70 CRI	UL Universal 120-277V - All lumen packages UH Universal 347-480V - 40L & 50L lumen packages only UM Universal 208-480V - 65L lumen package only	BK Black BZ Bronze SV Silver WH White	F Fuse - When code dictates fusing, use time delay fuse - Available for U.S. applications only PML Programmable Multi-Level, up to 40° Mounting Height - Refer to PML spec sheet for details - Not available with 65L - Intended for downlight applications at 0° tilt Q9/Q8/Q7/Q6/Q5/Q4/Q3/Q2/Q1 Field Adjustable Output - Must select Q9, Q8, Q7, Q6, Q5, Q4, Q3, Q2, or Q1 - Not available with 65L when ordered w/R option - Offers full range adjustability - Refer to pages 13-15 for power and lumen values R NEMA® 7-Pin Photocell Receptacle - 7-pin receptacle per ANSI C136.41 - Intended for downlight applications with maximum 45° tilt - Factory connected 0-10V dim leads - 12" [305mm] seven-conductor leads exit luminaire - Photocell and shorting cap by others - Not available with 65L when ordered w/Q option RL Rotate Left - LED and optic are rotated to the left - Refer to RR/RL configuration diagram on page 11 for optic directionality RR Rotate Right - LED and optic are rotated to the right - Refer to RR/RL configuration diagram on page 11 for optic directionality

* Available with Backlight Shield when ordered with field-installed accessory (see table above)

** Lumen Package selection codes identify approximate light output only. Actual lumen output levels vary depending on CCT and optic selection. Refer to Initial Delivered Lumen tables for specific lumen values

DA Mount

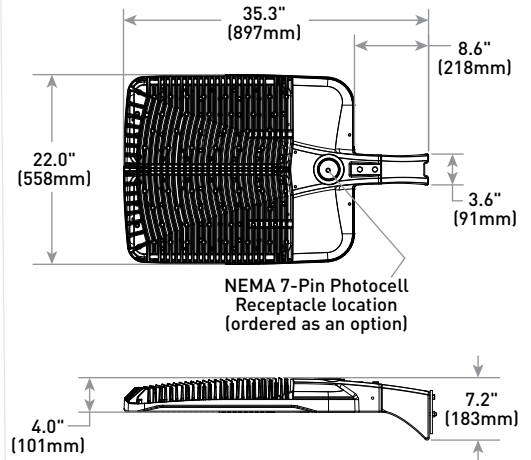

Lumen Package	Voltage	Weight
40/50L	120-480V	70.0 lbs. (31.8kg)
65L	120-480V	72.0 lbs. (32.7kg)



Rev. Date: V6 10/18/2018



Product Specifications

CREE TRUEWHITE® TECHNOLOGY

A revolutionary way to generate high-quality white light, Cree TrueWhite® Technology is a patented approach that delivers an exclusive combination of 90+ CRI, beautiful light characteristics and lifelong color consistency, all while maintaining high luminous efficacy – a true no compromise solution.

CONSTRUCTION & MATERIALS

- Slim, low profile design minimizes wind load requirements
- Luminaire housing is rugged die cast aluminum with an integral, weathertight LED driver compartment and high-performance heat sink
- Convenient interlocking mounting method on direct arm mount. Mounting adaptor is rugged die cast aluminum and mounts to 3-6" (76-152mm) square or round pole, secured by two 5/16-18 UNC bolts spaced on 2" (51mm) centers
- Adjustable arm that mounts to a horizontal or vertical 2" (51mm) IP, 2.375-2.50" (60-64mm) O.D. steel tenon. Tenon length must be a minimum of 3.75" (95mm)
- Adjustable arm mount can be adjusted 180° in 5.0° increments
- Includes 12" (305mm) 18/5 or 16/5 leads exiting the luminaire. When ordered with R option, 12" (305mm) 18/7 or 16/7 leads are provided
- Designed for uplight and downlight applications
- Exclusive Colorfast DeltaGuard® finish features an E-Coat epoxy primer with an ultra-durable powder topcoat, providing excellent resistance to corrosion, ultraviolet degradation and abrasion. Silver, bronze, black, and white are available
- **Weight:** See Dimension and Weight Chart on pages 1 and 12

ELECTRICAL SYSTEM

- **Input Voltage:** 120-277V, 208-480V or 347-480V, 50/60Hz, Class 1 drivers
- **Power Factor:** > 0.9 at full load
- **Total Harmonic Distortion:** < 20% at full load
- Integral 10kV surge suppression protection standard
- When code dictates fusing, a slow blow fuse or type C/D breaker should be used to address inrush current
- Designed with 0-10V dimming capabilities. For 65L SKUs with UL voltage, dimming control lines must be >1V when operated at 277V. Controls by others
- Refer to Dimming spec sheet for details
- **Maximum 10V Source Current:** 0.30mA
- **Operating Temperature Range:** -40°C to 40°C (-40° F to 104° F)

REGULATORY & VOLUNTARY QUALIFICATIONS

- cULus Listed
- Suitable for wet locations
- Consult factory for CE Certified products
- Certified to ANSI C136.31-2001, 3G bridge and overpass vibration standards
- 10kV surge suppression protection tested in accordance with IEEE/ANSI C62.41.2
- Meets FCC Part 15, Subpart B, Class A standards for conducted and radiated emissions
- Luminaire and finish endurance tested to withstand 5,000 hours of elevated ambient salt fog conditions as defined in ASTM Standard B 117
- Meets Buy American requirements within ARRA
- RoHS compliant. Consult factory for additional details
- DLC and DLC Premium qualified versions available. Some exceptions apply. Please refer to <https://www.designlights.org/search/> for most current information
- OSQ-HO luminaires are enclosure rated IP66 per IEC 60598-1 when ordered without the R option
- Dark Sky Friendly, IDA Approved when ordered with 30K CCT and DA mount. Please refer to <http://darksky.org/fsa/fsa-products/> for most current information

CA RESIDENTS WARNING: Cancer and Reproductive Harm –

 www.p65warnings.ca.gov

Electrical Data*							
Lumen Package	System Watts 120-480V	Total Current (A)					
		120V	208V	240V	277V	347V	480V
40L	341	2.93	1.65	1.43	1.23	1.00	0.71
50L	420	3.61	2.03	1.76	1.51	1.23	0.87
65L	550	4.73	2.66	2.30	1.98	1.59	1.15

* Electrical data at 25°C (77°F). Actual wattage may differ by +/- 10% when operating between 120-480V +/- 10%

OSQ Series Ambient Adjusted Lumen Maintenance ¹						
Ambient	Optic	Initial LMF	25K hr Projected ² LMF	50K hr Projected ² LMF	75K hr Projected ² / Calculated ³ LMF	100K hr Projected ² / Calculated ³ LMF
5°C (41°F)	Asymmetric	1.04	1.02	1.01	1.00 ³	0.99 ³
	Symmetric	1.05	1.04	1.03	1.03 ²	1.02 ²
10°C (50°F)	Asymmetric	1.03	1.01	1.00	0.99 ³	0.98 ³
	Symmetric	1.04	1.03	1.02	1.01 ²	1.00 ²
15°C (59°F)	Asymmetric	1.02	1.00	0.99	0.98 ³	0.97 ³
	Symmetric	1.02	1.02	1.01	1.00 ²	0.99 ²
20°C (68°F)	Asymmetric	1.01	0.99	0.98	0.97 ³	0.96 ³
	Symmetric	1.01	1.01	1.00	0.99 ²	0.98 ²
25°C (77°F)	Asymmetric	1.00	0.98	0.97	0.96 ³	0.95 ³
	Symmetric	1.00	0.99	0.98	0.98 ²	0.97 ²

¹ Lumen maintenance values at 25°C (77°F) are calculated per TM-21 based on LM-80 data and in-situ luminaire testing. Luminaire ambient temperature factors (LATF) have been applied to all lumen maintenance factors. Please refer to the [Temperature Zone Reference Document](#) for outdoor average nighttime ambient conditions.

² In accordance with IESNA TM-21-11, Projected Values represent interpolated value based on time durations that are within six times (6X) the IESNA LM-80-08 total test duration (in hours) for the device under testing (DUT) i.e. the packaged LED chip

³ In accordance with IESNA TM-21-11, Calculated Values represent time durations that exceed six times (6X) the IESNA LM-80-08 total test duration (in hours) for the device under testing (DUT) i.e. the packaged LED chip

OSQ™ High Output LED Area/Flood Luminaire featuring Cree TrueWhite® Technology

Photometry

All published luminaire photometric testing performed to IESNA LM-79-08 standards by a NVLAP accredited laboratory. To obtain an IES file specific to your project consult: <http://lighting.cree.com/products/outdoor/area/area-osq-high-output>

2ME

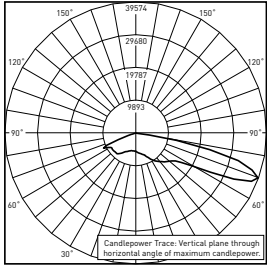

CESTL Test Report #: PL10951-001A
OSQ-HO-A--2ME-40L-40K-UL**
Initial Delivered Lumens: 45,012

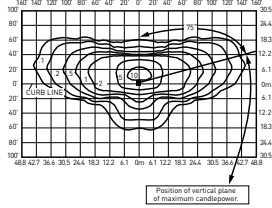

OSQ-HO-A--2ME-40L-40K-UL**
Mounting Height: 25' (7.6m) A.F.G.
Initial Delivered Lumens: 41,880
Initial FC at grade

Type II Medium Distribution								
Lumen Package	3000K/70 CRI		4000K/70 CRI		5000K/90 CRI		5700K/70 CRI	
	Initial Delivered Lumens*	BUG Ratings** Per TM-15-11	Initial Delivered Lumens*	BUG Ratings** Per TM-15-11	Initial Delivered Lumens*	BUG Ratings** Per TM-15-11	Initial Delivered Lumens*	BUG Ratings** Per TM-15-11
40L	39,751	B4 U0 G4	41,880	B4 U0 G5	33,920	B4 U0 G4	42,702	B4 U0 G5
50L	48,950	B4 U0 G5	51,571	B4 U0 G5	41,434	B4 U0 G5	52,583	B4 U0 G5
65L	63,945	B5 U0 G5	67,369	B5 U0 G5	53,848	B4 U0 G5	68,691	B5 U0 G5

* Initial delivered lumens at 25°C (77°F). Actual production yield may vary between -10 and +10% of initial delivered lumens
 ** For more information on the IES BUG (Backlight-Uplight-Glare) Rating visit: <https://www.ies.org/wp-content/uploads/2017/03/TM-15-11BUGRatingsAddendum.pdf>. Valid with no tilt

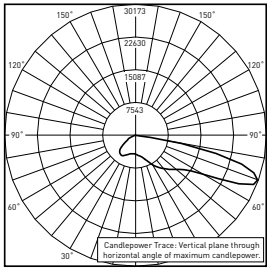

CESTL Test Report #: PL10952-001A
OSQ-HO-A--2ME-40L-40K-UL**
w/OSQ-HO-BLSF
Initial Delivered Lumens: 35,531

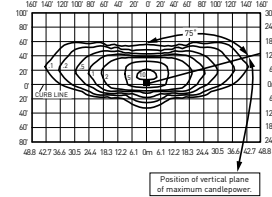

OSQ-HO-A--2ME-40L-40K-UL**
w/OSQ-HO-BLSF
Mounting Height: 25' (7.6m) A.F.G.
Initial Delivered Lumens: 33,504
Initial FC at grade

Type II Medium w/BLS Distribution								
Lumen Package	3000K/70 CRI		4000K/70 CRI		5000K/90 CRI		5700K/70 CRI	
	Initial Delivered Lumens*	BUG Ratings** Per TM-15-11	Initial Delivered Lumens*	BUG Ratings** Per TM-15-11	Initial Delivered Lumens*	BUG Ratings** Per TM-15-11	Initial Delivered Lumens*	BUG Ratings** Per TM-15-11
40L	31,801	B3 U0 G4	33,504	B3 U0 G4	27,136	B3 U0 G4	34,162	B3 U0 G4
50L	39,160	B3 U0 G4	41,257	B3 U0 G5	33,147	B3 U0 G4	42,066	B3 U0 G5
65L	51,156	B3 U0 G5	53,895	B3 U0 G5	43,078	B3 U0 G5	54,953	B3 U0 G5

* Initial delivered lumens at 25°C (77°F). Actual production yield may vary between -10 and +10% of initial delivered lumens
 ** For more information on the IES BUG (Backlight-Uplight-Glare) Rating visit: <https://www.ies.org/wp-content/uploads/2017/03/TM-15-11BUGRatingsAddendum.pdf>. Valid with no tilt

OSQ™ High Output LED Area/Flood Luminaire featuring Cree TrueWhite® Technology

Photometry

All published luminaire photometric testing performed to IESNA LM-79-08 standards by a NVLAP accredited laboratory. To obtain an IES file specific to your project consult: <http://lighting.cree.com/products/outdoor/area/area-osq-high-output>

3ME

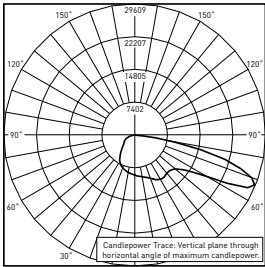

CESTL Test Report #: PL10953-001A
OSQ-HO-A-**-3ME-40L-40K-UL
Initial Delivered Lumens: 44,770

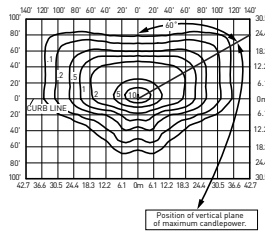

OSQ-HO-A-**-3ME-40L-40K-UL
Mounting Height: 25' (7.6m) A.F.G.
Initial Delivered Lumens: 41,880
Initial FC at grade

Type III Medium Distribution								
Lumen Package	3000K/70 CRI		4000K/70 CRI		5000K/90 CRI		5700K/70 CRI	
	Initial Delivered Lumens*	BUG Ratings** Per TM-15-11	Initial Delivered Lumens*	BUG Ratings** Per TM-15-11	Initial Delivered Lumens*	BUG Ratings** Per TM-15-11	Initial Delivered Lumens*	BUG Ratings** Per TM-15-11
40L	39,751	B4 U0 G5	41,880	B4 U0 G5	33,920	B4 U0 G4	42,702	B4 U0 G5
50L	48,950	B4 U0 G5	51,571	B4 U0 G5	41,434	B4 U0 G5	52,583	B4 U0 G5
65L	63,945	B4 U0 G5	67,369	B5 U0 G5	53,848	B4 U0 G5	68,691	B5 U0 G5

* Initial delivered lumens at 25°C (77°F). Actual production yield may vary between -10 and +10% of initial delivered lumens

** For more information on the IES BUG (Backlight-Uplight-Glare) Rating visit: <https://www.ies.org/wp-content/uploads/2017/03/TM-15-11BUGRatingsAddendum.pdf>. Valid with no tilt

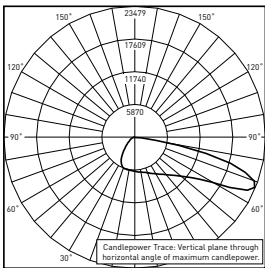

CESTL Test Report #: PL10954-001A
OSQ-HO-A-**-3ME-40L-40K-UL
w/OSQ-HO-BLSF
Initial Delivered Lumens: 32,977

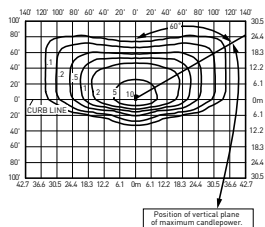

OSQ-HO-A-**-3ME-40L-40K-UL
w/OSQ-HO-BLSF
Mounting Height: 25' (7.6m) A.F.G.
Initial Delivered Lumens: 34,342
Initial FC at grade

Type III Medium w/BLS Distribution								
Lumen Package	3000K/70 CRI		4000K/70 CRI		5000K/90 CRI		5700K/70 CRI	
	Initial Delivered Lumens*	BUG Ratings** Per TM-15-11	Initial Delivered Lumens*	BUG Ratings** Per TM-15-11	Initial Delivered Lumens*	BUG Ratings** Per TM-15-11	Initial Delivered Lumens*	BUG Ratings** Per TM-15-11
40L	32,596	B3 U0 G4	34,342	B3 U0 G5	27,814	B3 U0 G4	35,016	B3 U0 G5
50L	40,139	B3 U0 G5	42,288	B4 U0 G5	33,976	B3 U0 G5	43,118	B4 U0 G5
65L	52,435	B4 U0 G5	55,243	B4 U0 G5	44,155	B4 U0 G5	56,327	B4 U0 G5

* Initial delivered lumens at 25°C (77°F). Actual production yield may vary between -10 and +10% of initial delivered lumens

** For more information on the IES BUG (Backlight-Uplight-Glare) Rating visit: <https://www.ies.org/wp-content/uploads/2017/03/TM-15-11BUGRatingsAddendum.pdf>. Valid with no tilt

OSQ™ High Output LED Area/Flood Luminaire featuring Cree TrueWhite® Technology

Photometry

All published luminaire photometric testing performed to IESNA LM-79-08 standards by a NVLAP accredited laboratory. To obtain an IES file specific to your project consult: <http://lighting.cree.com/products/outdoor/area/area-osq-high-output>

4ME

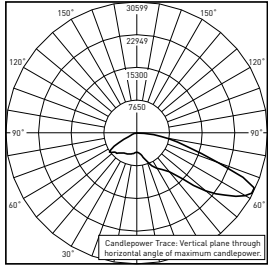

CESTL Test Report #: PL09256-001A
OSQ-HO-A--4ME-40L-40K-UL**
Initial Delivered Lumens: 44,936

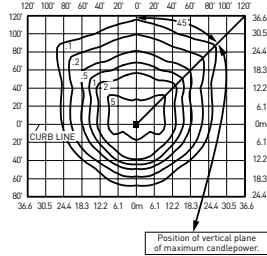

OSQ-HO-A--4ME-40L-40K-UL**
Mounting Height: 25' (7.6m) A.F.G.
Initial Delivered Lumens: 41,880
Initial FC at grade

Type IV Medium Distribution								
Lumen Package	3000K/70 CRI		4000K/70 CRI		5000K/90 CRI		5700K/70 CRI	
	Initial Delivered Lumens*	BUG Ratings** Per TM-15-11	Initial Delivered Lumens*	BUG Ratings** Per TM-15-11	Initial Delivered Lumens*	BUG Ratings** Per TM-15-11	Initial Delivered Lumens*	BUG Ratings** Per TM-15-11
40L	39,751	B4 U0 G4	41,880	B5 U0 G4	33,920	B4 U0 G4	42,702	B5 U0 G4
50L	48,950	B5 U0 G5	51,571	B5 U0 G5	41,434	B4 U0 G4	52,583	B5 U0 G5
65L	63,945	B5 U0 G5	67,369	B5 U0 G5	53,848	B5 U0 G5	68,691	B5 U0 G5

* Initial delivered lumens at 25°C (77°F). Actual production yield may vary between -10 and +10% of initial delivered lumens

** For more information on the IES BUG (Backlight-Uplight-Glare) Rating visit: <https://www.ies.org/wp-content/uploads/2017/03/TM-15-11BUGRatingsAddendum.pdf>. Valid with no tilt

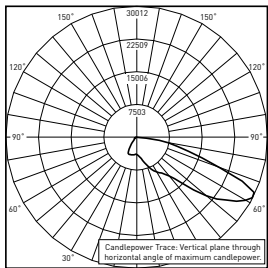

CESTL Test Report #: PL09256-002A
OSQ-HO-A--4ME-40L-40K-UL**
w/OSQ-HO-BLSF
Initial Delivered Lumens: 35,406

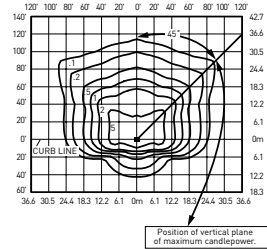

OSQ-HO-A--4ME-40L-40K-UL**
w/OSQ-HO-BLSF
Mounting Height: 25' (7.6m) A.F.G.
Initial Delivered Lumens: 33,085
Initial FC at grade

Type IV Medium w/BLS Distribution								
Lumen Package	3000K/70 CRI		4000K/70 CRI		5000K/90 CRI		5700K/70 CRI	
	Initial Delivered Lumens*	BUG Ratings** Per TM-15-11	Initial Delivered Lumens*	BUG Ratings** Per TM-15-11	Initial Delivered Lumens*	BUG Ratings** Per TM-15-11	Initial Delivered Lumens*	BUG Ratings** Per TM-15-11
40L	31,403	B3 U0 G4	33,085	B3 U0 G4	26,797	B3 U0 G4	33,735	B3 U0 G4
50L	38,671	B3 U0 G5	40,741	B3 U0 G5	32,733	B3 U0 G4	41,541	B3 U0 G5
65L	50,517	B4 U0 G5	53,222	B4 U0 G5	42,540	B3 U0 G5	54,266	B4 U0 G5

* Initial delivered lumens at 25°C (77°F). Actual production yield may vary between -10 and +10% of initial delivered lumens

** For more information on the IES BUG (Backlight-Uplight-Glare) Rating visit: <https://www.ies.org/wp-content/uploads/2017/03/TM-15-11BUGRatingsAddendum.pdf>. Valid with no tilt

OSQ™ High Output LED Area/Flood Luminaire featuring Cree TrueWhite® Technology

Photometry

All published luminaire photometric testing performed to IESNA LM-79-08 standards by a NVLAP accredited laboratory. To obtain an IES file specific to your project consult: <http://lighting.cree.com/products/outdoor/area/area-osq-high-output>

AF

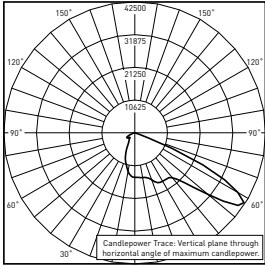

CESTL Test Report #: PL10910-001A
OSQ-HO-A--AF-40L-40K-UL**
Initial Delivered Lumens: 44,921

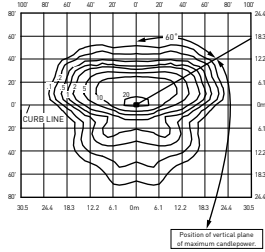

OSQ-HO-A--AF-40L-40K-UL**
Mounting Height: 25' (7.6m) A.F.G.
Initial Delivered Lumens: 41,880
Initial FC at grade

Automotive FrontLineOptic™ Distribution								
Lumen Package	3000K/70 CRI		4000K/70 CRI		5000K/90 CRI		5700K/70 CRI	
	Initial Delivered Lumens*	BUG Ratings** Per TM-15-11	Initial Delivered Lumens*	BUG Ratings** Per TM-15-11	Initial Delivered Lumens*	BUG Ratings** Per TM-15-11	Initial Delivered Lumens*	BUG Ratings** Per TM-15-11
40L	39,751	B4 U0 G3	41,880	B4 U0 G3	33,920	B3 U0 G3	42,702	B4 U0 G3
50L	48,950	B4 U0 G3	51,571	B4 U0 G3	41,434	B4 U0 G3	52,583	B4 U0 G3
65L	63,945	B4 U0 G4	67,369	B4 U0 G4	53,848	B4 U0 G3	68,691	B4 U0 G4

* Initial delivered lumens at 25°C (77°F). Actual production yield may vary between -10 and +10% of initial delivered lumens

** For more information on the IES BUG (Backlight-Uplight-Glare) Rating visit: <https://www.ies.org/wp-content/uploads/2017/03/TM-15-11BUGRatingsAddendum.pdf>. Valid with no tilt

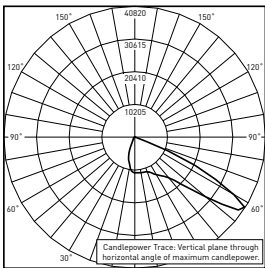

CESTL Test Report #: PL10911-001A
OSQ-HO-A--AF-40L-40K-UL**
w/OSQ-HO-BLSF
Initial Delivered Lumens: 35,558

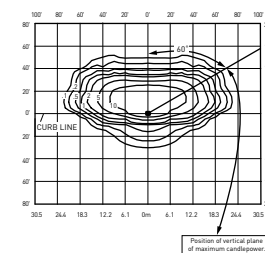

OSQ-HO-A--AF-40L-40K-UL**
w/OSQ-HO-BLSF
Mounting Height: 25' (7.6m) A.F.G.
Initial Delivered Lumens: 33,151
Initial FC at grade

Automotive FrontLineOptic™ w/BLS Distribution								
Lumen Package	3000K/70 CRI		4000K/70 CRI		5000K/90 CRI		5700K/70 CRI	
	Initial Delivered Lumens*	BUG Ratings** Per TM-15-11	Initial Delivered Lumens*	BUG Ratings** Per TM-15-11	Initial Delivered Lumens*	BUG Ratings** Per TM-15-11	Initial Delivered Lumens*	BUG Ratings** Per TM-15-11
40L	31,466	B3 U0 G2	33,151	B3 U0 G2	26,850	B3 U0 G2	33,802	B3 U0 G2
50L	38,747	B3 U0 G2	40,822	B3 U0 G3	32,798	B3 U0 G2	41,623	B3 U0 G3
65L	50,617	B4 U0 G3	53,327	B4 U0 G3	42,625	B3 U0 G3	54,374	B4 U0 G3

* Initial delivered lumens at 25°C (77°F). Actual production yield may vary between -10 and +10% of initial delivered lumens

** For more information on the IES BUG (Backlight-Uplight-Glare) Rating visit: <https://www.ies.org/wp-content/uploads/2017/03/TM-15-11BUGRatingsAddendum.pdf>. Valid with no tilt

OSQ™ High Output LED Area/Flood Luminaire featuring Cree TrueWhite® Technology

Photometry

All published luminaire photometric testing performed to IESNA LM-79-08 standards by a NVLAP accredited laboratory. To obtain an IES file specific to your project consult: <http://lighting.cree.com/products/outdoor/area/area-osq-high-output>

5ME

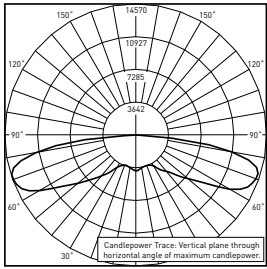

CESTL Test Report #: PL09257-001A
OSQ-HO-A--5ME-40L-40K-UL**
Initial Delivered Lumens: 35,159

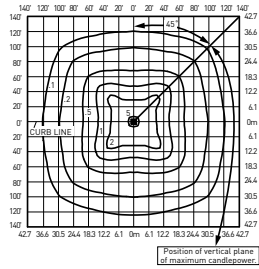

OSQ-HO-A--5ME-40L-40K-UL**
Mounting Height: 25' (7.6m) A.F.G.
Initial Delivered Lumens: 39,332
Initial FC at grade

Type V Medium Distribution								
Lumen Package	3000K/70 CRI		4000K/70 CRI		5000K/90 CRI		5700K/70 CRI	
	Initial Delivered Lumens*	BUG Ratings** Per TM-15-11	Initial Delivered Lumens*	BUG Ratings** Per TM-15-11	Initial Delivered Lumens*	BUG Ratings** Per TM-15-11	Initial Delivered Lumens*	BUG Ratings** Per TM-15-11
40L	37,169	B5 U0 G5	39,332	B5 U0 G5	31,689	B5 U0 G5	40,155	B5 U0 G5
50L	45,389	B5 U0 G5	48,031	B5 U0 G5	38,871	B5 U0 G5	49,035	B5 U0 G5
65L	59,011	B5 U0 G5	62,445	B5 U0 G5	49,959	B5 U0 G5	63,751	B5 U0 G5

* Initial delivered lumens at 25°C (77°F). Actual production yield may vary between -10 and +10% of initial delivered lumens

** For more information on the IES BUG (Backlight-Uplight-Glare) Rating visit: <https://www.ies.org/wp-content/uploads/2017/03/TM-15-11BUGRatingsAddendum.pdf>. Valid with no tilt

5SH

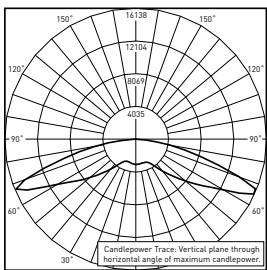

CESTL Test Report #: PL09258-001A
OSQ-HO-A--5SH-40L-40K-UL**
Initial Delivered Lumens: 42,362

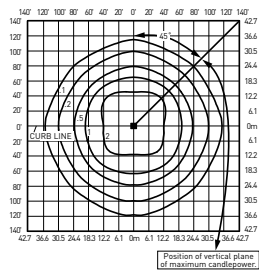

OSQ-HO-A--5SH-40L-40K-UL**
Mounting Height: 25' (7.6m) A.F.G.
Initial Delivered Lumens: 41,542
Initial FC at grade

Type V Short Distribution								
Lumen Package	3000K/70 CRI		4000K/70 CRI		5000K/90 CRI		5700K/70 CRI	
	Initial Delivered Lumens*	BUG Ratings** Per TM-15-11	Initial Delivered Lumens*	BUG Ratings** Per TM-15-11	Initial Delivered Lumens*	BUG Ratings** Per TM-15-11	Initial Delivered Lumens*	BUG Ratings** Per TM-15-11
40L	39,258	B5 U0 G5	41,542	B5 U0 G5	33,469	B5 U0 G5	42,411	B5 U0 G5
50L	47,939	B5 U0 G5	50,729	B5 U0 G5	41,055	B5 U0 G5	51,790	B5 U0 G5
65L	62,326	B5 U0 G5	65,953	B5 U0 G5	52,766	B5 U0 G5	67,332	B5 U0 G5

* Initial delivered lumens at 25°C (77°F). Actual production yield may vary between -10 and +10% of initial delivered lumens

** For more information on the IES BUG (Backlight-Uplight-Glare) Rating visit: <https://www.ies.org/wp-content/uploads/2017/03/TM-15-11BUGRatingsAddendum.pdf>. Valid with no tilt

OSQ™ High Output LED Area/Flood Luminaire featuring Cree TrueWhite® Technology

Photometry

All published luminaire photometric testing performed to IESNA LM-79-08 standards by a NVLAP accredited laboratory. To obtain an IES file specific to your project consult: <http://lighting.cree.com/products/outdoor/area/area-osq-high-output>

15D

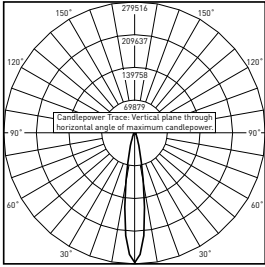

CESTL Test Report #: PL09259-001A
OSQ-HO-A**-15D-40L-40K-UL
Initial Delivered Lumens: 43,172

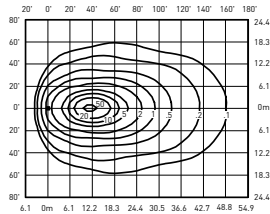

OSQ-HO-A**-15D-40L-40K-UL
Mounting Height: 25' (7.6m) A.F.G., 60° Tilt
Initial Delivered Lumens: 41,542
Initial FC at grade

15° Flood Distribution				
Lumen Package	3000K/70 CRI	4000K/70 CRI	5000K/90 CRI	5700K/70 CRI
	Initial Delivered Lumens*	Initial Delivered Lumens*	Initial Delivered Lumens*	Initial Delivered Lumens*
40L	39,258	41,542	33,469	42,411
50L	47,939	50,729	41,055	51,790
65L	62,326	65,953	52,766	67,332

* Initial delivered lumens at 25°C (77°F). Actual production yield may vary between -10 and +10% of initial delivered lumens

25D

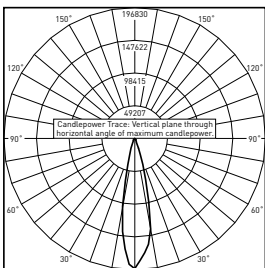

CESTL Test Report #: PL09260-001A
OSQ-HO-A**-25D-40L-40K-UL
Initial Delivered Lumens: 43,263

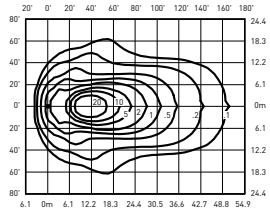

OSQ-HO-A**-25D-40L-40K-UL
Mounting Height: 25' (7.6m) A.F.G., 60° Tilt
Initial Delivered Lumens: 41,542
Initial FC at grade

25° Flood Distribution				
Lumen Package	3000K/70 CRI	4000K/70 CRI	5000K/90 CRI	5700K/70 CRI
	Initial Delivered Lumens*	Initial Delivered Lumens*	Initial Delivered Lumens*	Initial Delivered Lumens*
40L	39,258	41,542	33,469	42,411
50L	47,939	50,729	41,055	51,790
65L	62,326	65,953	52,766	67,332

* Initial delivered lumens at 25°C (77°F). Actual production yield may vary between -10 and +10% of initial delivered lumens

Photometry

All published luminaire photometric testing performed to IESNA LM-79-08 standards by a NVLAP accredited laboratory. To obtain an IES file specific to your project consult: <http://lighting.cree.com/products/outdoor/area/area-osq-high-output>

40D

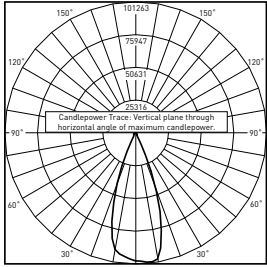

CESTL Test Report #: PL09261-001A
OSQ-HO-A-**-40D-40L-40K-UL
Initial Delivered Lumens: 43,698

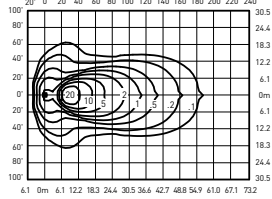

OSQ-HO-A-**-40D-40L-40K-UL
Mounting Height: 25' (7.6m) A.F.G., 60° Tilt
Initial Delivered Lumens: 41,542
Initial FC at grade

40° Flood Distribution				
Lumen Package	3000K/70 CRI	4000K/70 CRI	5000K/90 CRI	5700K/70 CRI
	Initial Delivered Lumens*	Initial Delivered Lumens*	Initial Delivered Lumens*	Initial Delivered Lumens*
40L	39,258	41,542	33,469	42,411
50L	47,939	50,729	41,055	51,790
65L	62,326	65,953	52,766	67,332

* Initial delivered lumens at 25°C (77°F). Actual production yield may vary between -10 and +10% of initial delivered lumens

60D

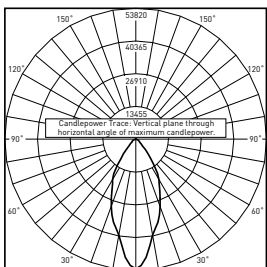

CESTL Test Report #: PL09262-001A
OSQ-HO-A-**-60D-40L-40K-UL
Initial Delivered Lumens: 42,715

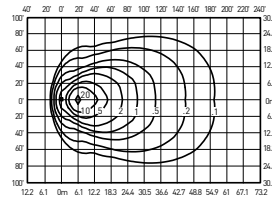

OSQ-HO-A-**-60D-40L-40K-UL
Mounting Height: 25' (7.6m) A.F.G., 60° Tilt
Initial Delivered Lumens: 41,542
Initial FC at grade

60° Flood Distribution				
Lumen Package	3000K/70 CRI	4000K/70 CRI	5000K/90 CRI	5700K/70 CRI
	Initial Delivered Lumens*	Initial Delivered Lumens*	Initial Delivered Lumens*	Initial Delivered Lumens*
40L	39,258	41,542	33,469	42,411
50L	47,939	50,729	41,055	51,790
65L	62,326	65,953	52,766	67,332

* Initial delivered lumens at 25°C (77°F). Actual production yield may vary between -10 and +10% of initial delivered lumens

Photometry

All published luminaire photometric testing performed to IESNA LM-79-08 standards by a NVLAP accredited laboratory. To obtain an IES file specific to your project consult: <http://lighting.cree.com/products/outdoor/area/area-osq-high-output>

120D

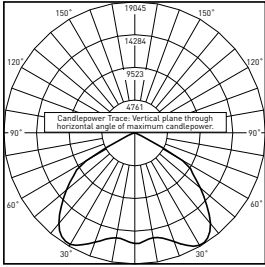

CESTL Test Report #: PL09725-001A
OSQ-HO-A**-120D-40L-40K-UL
Initial Delivered Lumens: 43,044

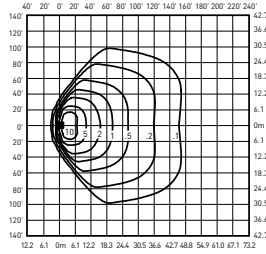

OSQ-HO-A**-120D-40L-40K-UL
Mounting Height: 25' (7.6m) A.F.G., 60° Tilt
Initial Delivered Lumens: 41,542
Initial FC at grade

120° Flood Distribution				
Lumen Package	3000K/70 CRI	4000K/70 CRI	5000K/90 CRI	5700K/70 CRI
	Initial Delivered Lumens*	Initial Delivered Lumens*	Initial Delivered Lumens*	Initial Delivered Lumens*
40L	39,258	41,542	33,469	42,411
50L	47,939	50,729	41,055	51,790
65L	62,326	65,953	52,766	67,332

* Initial delivered lumens at 25°C (77°F). Actual production yield may vary between -10 and +10% of initial delivered lumens

WSN

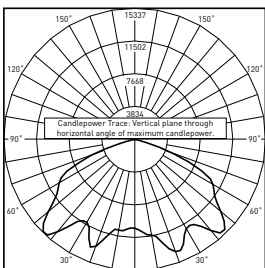

CESTL Test Report #: PL07695-001A
OSQ-A**-WSN-U-30K-UL
Initial Delivered Lumens: 23,116

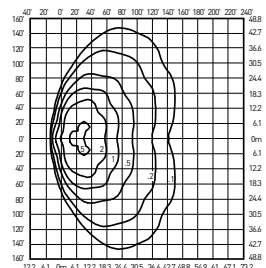

OSQ-HO-A**-WSN-40L-40K-UL
Mounting Height: 25' (7.6m) A.F.G., 60° tilt
Initial Delivered Lumens: 41,542
Initial FC at grade

Wide Sign Distribution				
Lumen Package	3000K/70 CRI	4000K/70 CRI	5000K/90 CRI	5700K/70 CRI
	Initial Delivered Lumens*	Initial Delivered Lumens*	Initial Delivered Lumens*	Initial Delivered Lumens*
40L	39,258	41,542	33,469	42,411
50L	47,939	50,729	41,055	51,790
65L	62,326	65,953	52,766	67,332

* Initial delivered lumens at 25°C (77°F). Actual production yield may vary between -10 and +10% of initial delivered lumens

Luminaire EPA

Adjustable Arm Mount – OSQ-HO-AA Weight: 40L/50L, 120-480V: 73.0 lbs. (33.1kg); 65L, 120-480V: 75.0 lbs. (34.0kg)							
Single	2 @ 180°	2 @ 90°	3 @ 90°	3 @ 120°	3 @ 180°	4 @ 180°	4 @ 90°
Tenon Configuration [0° - 90° Tilt]; If used with Cree tenons, please add tenon EPA with Luminaire EPA							
PB-1A*; PW-1A3**	PB-2A*; PB-2R2.375; PW-2A3**	PB-2A*; PB-2R2.375; PW-2A3**	PB-3A*; PB-3R2.375	PB-3A*; PB-3R2.375	PB-3A*; PB-3R2.375	PB-4A*(180); PB-4R2.375	PB-4A*(90); PB-4R2.3(90)
0° Tilt							
1.16	2.03	2.03	2.90	2.63	2.90	3.77	3.77
10° Tilt							
1.67	3.06	3.06	4.45	4.27	4.45	5.83	5.83
20° Tilt							
2.35	4.41	4.41	6.48	6.34	6.48	8.54	8.54
30° Tilt							
2.99	5.70	5.70	8.41	8.29	8.41	11.12	11.12
45° Tilt							
3.85	7.41	7.41	10.98	10.89	10.98	14.54	14.54
60° Tilt							
4.51	8.73	8.73	12.95	12.91	12.95	17.18	17.18
70° Tilt							
4.83	9.37	9.37	13.91	13.88	13.91	18.45	18.45
80° Tilt							
5.02	9.76	9.76	14.50	14.44	14.50	19.24	19.24
90° Tilt							
5.02	9.76	9.76	14.50	14.44	14.50	19.24	19.24

Fixed Arm Mount – OSQ-HO-DA Weight: 40L/50L, 120-480V: 70.0 lbs. (31.8kg); 65L, 120-480V: 72.0 lbs. (32.7kg)					
Single	2 @ 180°	2 @ 90°	3 @ 90°	3 @ 120°	4 @ 90°
1.06	1.93	1.93	2.80	2.53	3.67

* Specify pole size: 3 [3"], 4 [4"], 5 [5"], or 6 [6"] for single, double or triple luminaire orientation or 4 [4"], 5 [5"], or 6 [6"] for quad luminaire orientation
 ** These EPA values must be multiplied by the following ratio: Fixture Mounting Height/Total Pole Height. Specify pole size: 3 [3"], 4 [4"], 5 [5"], or 6 [6"]

AA Mount



Lumen Package	Voltage	Weight
40/50L	120-480V	73.0 lbs. (33.1kg)
65L	120-480V	75.0 lbs. (34.0kg)

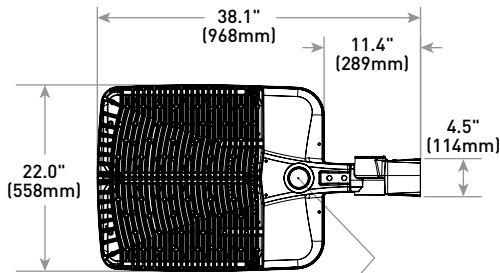

NEMA Photocell Receptacle location (ordered as an option)

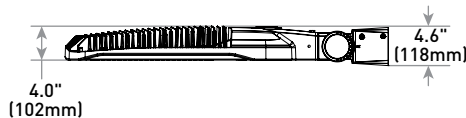

RR/RL Configuration

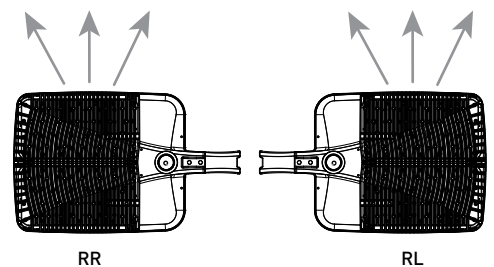

Tenon EPA

Part Number	EPA
PB-1A*	None
PB-2A*	0.82
PB-3A*	1.52
PB-4A*[180]	2.22
PB-4A*[90]	1.11
PB-2R2.375	0.92
PB-3R2.375	1.62
PB-4R2.375	2.32
PW-1A3**	0.47
PW-2A3**	0.94
WM-2	0.08
WM-4	0.25
WM-DM	None

* Specify pole size: 3 {3"}, 4 {4"}, 5 {5"}, or 6 {6"} for single, double or triple luminaire orientation or 4 {4"}, 5 {5"}, or 6 {6"} for quad luminaire orientation
 ** These EPA values must be multiplied by the following ratio: Fixture Mounting Height/Total Pole Height. Specify pole size: 3 {3"}, 4 {4"}, 5 {5"}, or 6 {6"}

Tenons and Brackets* (must specify color)			
Square Internal Mount Vertical Tenons (Steel) - Mounts to 3-6" (76-152mm) square aluminum or steel poles		Round External Mount Vertical Tenons (Steel) - Mounts to 2.375" (60mm) O.D. round aluminum or steel poles or tenons	
PB-1A* – Single	PB-4A*[90] – 90° Quad	PB-2R2.375 – Twin	PB-4R2.375 – Quad
PB-2A* – 180° Twin	PB-4A*[180] – 180° Quad	PB-3R2.375 – Triple	
PB-3A* – 180° Triple			
Wall Mount Brackets - Mounts to wall or roof		Mid-Pole Bracket - Mounts to square pole	
WM-2 – Horizontal for OSQ-HO-AA mount		PW-1A3** – Single	PW-2A3** – Double
WM-4 – L-Shape for OSQ-HO-AA mount			
WM-DM – Plate for OSQ-HO-DA mount			

* Refer to the [Bracket and Tenons spec sheet](#) for more details

Direct Mount Configurations

Compatibility with OSQ-HO-DA Direct Arm Mount					
Input Delivered Lumens	2 @ 90°	2 @ 180°	3 @ 90°	3 @ 120°	4 @ 90°
3" Square					
40L/50L/65L	N/A	✓	N/A	N/A	N/A
3" Round					
40L/50L/65L	N/A	✓	N/A	✓	N/A
4" Square					
40L/50L/65L	✓	✓	✓	N/A	✓
4" Round*					
40L/50L/65L	✓	✓	✓	✓	✓
5" Square					
40L/50L/65L	✓	✓	✓	N/A	✓
5" Round					
40L/50L/65L	✓	✓	✓	✓	✓
6" Square					
40L/50L/65L	✓	✓	✓	N/A	✓
6" Round					
40L/50L/65L	✓	✓	✓	✓	✓

* Note: only 0.10" clearance between mounts on 4 @ 90°

Field Adjustable Output (Q9/Q8/Q7/Q6/Q5/Q4/Q3/Q2/Q1) Option Description:

The Field Adjustable Output option enables the OSQ High Output area luminaires to be tuned to the exact needs of a particular application through multiple levels of adjustment. When ordered with the Q option, the luminaire will be shipped from the factory at the selected Q setting and will be fully adjustable between the nine settings.

Q Option Power & Lumen Data – 40L

Q Option Setting	CCT	System Watts 120-480V	Lumen Values							Optics Qualified on DLC QPL	
			Asymmetric	5ME	5SH & Floods	2ME w/BLS	3ME w/BLS	4ME w/BLS	AF w/BLS	Standard	Premium
Q9 (Full Power)	30K	341	39,751	37,169	39,258	31,801	32,596	31,403	31,466	5ME, 5SH, 15D, 25D, 40D, 60D, 120D, WSN	2ME, 3ME, 4ME, AF
	40K		41,880	39,332	41,542	33,504	34,342	33,085	33,151	5ME	2ME, 3ME, 4ME, AF, 5SH, 15D, 25D, 40D, 60D, 120D, WSN
	50K		33,920	31,689	33,469	27,136	27,814	26,797	26,850	2ME, 3ME, 4ME, AF, 5SH, 15D, 25D, 40D, 60D, 120D, WSN	N/A
	57K		42,702	40,155	42,411	34,162	35,016	33,735	33,802	5ME	2ME, 3ME, 4ME, AF, 5SH, 15D, 25D, 40D, 60D, 120D, WSN
Q8	30K	324	38,273	35,787	37,799	30,619	31,384	30,236	30,296	5ME, 5SH, 15D, 25D, 40D, 60D, 120D, WSN	2ME, 3ME, 4ME, AF
	40K		40,323	37,870	39,998	32,259	33,065	31,855	31,919	5ME	2ME, 3ME, 4ME, AF, 5SH, 15D, 25D, 40D, 60D, 120D, WSN
	50K		32,659	30,511	32,225	26,127	26,780	25,801	25,852	2ME, 3ME, 4ME, AF, 5SH, 15D, 25D, 40D, 60D, 120D, WSN	N/A
	57K		41,115	38,662	40,834	32,892	33,714	32,481	32,545	5ME	2ME, 3ME, 4ME, AF, 5SH, 15D, 25D, 40D, 60D, 120D, WSN
Q7	30K	306	36,375	34,012	35,923	29,100	29,827	28,736	28,793	5ME, 5SH, 15D, 25D, 40D, 60D, 120D, WSN	2ME, 3ME, 4ME, AF
	40K		38,323	35,991	38,013	30,658	31,425	30,275	30,335	5ME	2ME, 3ME, 4ME, AF, 5SH, 15D, 25D, 40D, 60D, 120D, WSN
	50K		31,039	28,997	30,626	24,831	25,451	24,521	24,569	2ME, 3ME, 4ME, AF, 5SH, 15D, 25D, 40D, 60D, 120D, WSN	N/A
	57K		39,075	36,744	38,809	31,260	32,042	30,870	30,931	5ME	2ME, 3ME, 4ME, AF, 5SH, 15D, 25D, 40D, 60D, 120D, WSN
Q6	30K	289	35,206	32,919	34,770	28,165	28,869	27,813	27,868	5ME, 5SH, 15D, 25D, 40D, 60D, 120D, WSN	2ME, 3ME, 4ME, AF
	40K		37,092	34,835	36,793	29,673	30,416	29,302	29,361	5ME	2ME, 3ME, 4ME, AF, 5SH, 15D, 25D, 40D, 60D, 120D, WSN
	50K		30,042	28,066	29,642	24,034	24,634	23,733	23,780	2ME, 3ME, 4ME, AF, 5SH, 15D, 25D, 40D, 60D, 120D, WSN	N/A
	57K		37,820	35,564	37,562	30,256	31,013	29,878	29,937	5ME	2ME, 3ME, 4ME, AF, 5SH, 15D, 25D, 40D, 60D, 120D, WSN
Q5	30K	263	32,241	30,146	31,841	25,793	26,437	25,470	25,521	5ME, 5SH, 15D, 25D, 40D, 60D, 120D, WSN	2ME, 3ME, 4ME, AF
	40K		33,967	31,901	33,693	27,174	27,854	26,834	26,888	5ME	2ME, 3ME, 4ME, AF, 5SH, 15D, 25D, 40D, 60D, 120D, WSN
	50K		27,511	25,702	27,146	22,009	22,559	21,734	21,777	2ME, 3ME, 4ME, AF, 5SH, 15D, 25D, 40D, 60D, 120D, WSN	N/A
	57K		34,634	32,568	34,398	27,708	28,400	27,361	27,415	5ME	2ME, 3ME, 4ME, AF, 5SH, 15D, 25D, 40D, 60D, 120D, WSN
Q4	30K	238	30,029	28,078	29,656	24,023	24,624	23,722	23,770	5ME, 5SH, 15D, 25D, 40D, 60D, 120D, WSN	2ME, 3ME, 4ME, AF
	40K		31,637	29,712	31,381	25,309	25,943	24,993	25,043	5ME	2ME, 3ME, 4ME, AF, 5SH, 15D, 25D, 40D, 60D, 120D, WSN
	50K		25,624	23,938	25,283	20,499	21,011	20,243	20,283	2ME, 3ME, 4ME, AF, 5SH, 15D, 25D, 40D, 60D, 120D, WSN	N/A
	57K		32,258	30,334	32,038	25,807	26,452	25,484	25,534	5ME	2ME, 3ME, 4ME, AF, 5SH, 15D, 25D, 40D, 60D, 120D, WSN
Q3	30K	212	26,969	25,217	26,634	21,575	22,115	21,305	21,348	5ME, 5SH, 15D, 25D, 40D, 60D, 120D, WSN	2ME, 3ME, 4ME, AF
	40K		28,413	26,685	28,184	22,731	23,299	22,446	22,491	5ME	2ME, 3ME, 4ME, AF, 5SH, 15D, 25D, 40D, 60D, 120D, WSN
	50K		23,013	21,499	22,707	18,410	18,870	18,180	18,216	2ME, 3ME, 4ME, AF, 5SH, 15D, 25D, 40D, 60D, 120D, WSN	N/A
	57K		28,971	27,243	28,774	23,177	23,756	22,887	22,933	5ME	2ME, 3ME, 4ME, AF, 5SH, 15D, 25D, 40D, 60D, 120D, WSN
Q2	30K	189	24,420	22,834	24,117	19,536	20,025	19,292	19,330	5ME, 5SH, 15D, 25D, 40D, 60D, 120D, WSN	2ME, 3ME, 4ME, AF
	40K		25,728	24,163	25,520	20,582	21,097	20,325	20,366	5ME	2ME, 3ME, 4ME, AF, 5SH, 15D, 25D, 40D, 60D, 120D, WSN
	50K		20,838	19,467	20,561	16,670	17,087	16,462	16,495	2ME, 3ME, 4ME, AF, 5SH, 15D, 25D, 40D, 60D, 120D, WSN	N/A
	57K		26,233	24,668	26,054	20,987	21,511	20,724	20,765	5ME	2ME, 3ME, 4ME, AF, 5SH, 15D, 25D, 40D, 60D, 120D, WSN
Q1	30K	169	22,108	20,672	21,834	17,687	18,129	17,465	17,500	5ME, 5SH, 15D, 25D, 40D, 60D, 120D, WSN	2ME, 3ME, 4ME, AF
	40K		23,292	21,875	23,105	18,634	19,100	18,401	18,438	5ME	2ME, 3ME, 4ME, AF, 5SH, 15D, 25D, 40D, 60D, 120D, WSN
	50K		18,865	17,625	18,615	15,092	15,469	14,904	14,933	2ME, 3ME, 4ME, AF, 5SH, 15D, 25D, 40D, 60D, 120D, WSN	N/A
	57K		23,750	22,333	23,588	19,000	19,475	18,762	18,800	5ME	2ME, 3ME, 4ME, AF, 5SH, 15D, 25D, 40D, 60D, 120D, WSN

Field Adjustable Output (Q9/Q8/Q7/Q6/Q5/Q4/Q3/Q2/Q1) Option Description:

The Field Adjustable Output option enables the OSQ High Output area luminaires to be tuned to the exact needs of a particular application through multiple levels of adjustment. When ordered with the Q option, the luminaire will be shipped from the factory at the selected Q setting and will be fully adjustable between the nine settings.

Q Option Power & Lumen Data – 50L

Q Option Setting	CCT	System Watts 120-480V	Lumen Values							Optics Qualified on DLC QPL	
			Asymmetric	5ME	5SH & Floods	2ME w/BLS	3ME w/BLS	4ME w/BLS	AF w/BLS	Standard	Premium
Q9 (Full Power)	30K	420	48,950	45,389	47,939	39,160	40,139	38,671	38,747	5ME, 5SH, 15D, 25D, 40D, 60D, 120D, WSN	2ME, 3ME, 4ME, AF
	40K		51,571	48,031	50,729	41,257	42,288	40,741	40,822	5ME	2ME, 3ME, 4ME, AF, 5SH, 15D, 25D, 40D, 60D, 120D, WSN
	50K		41,434	38,871	41,055	33,147	33,976	32,733	32,798	2ME, 3ME, 4ME, AF, 5SH, 15D, 25D, 40D, 60D, 120D, WSN	N/A
	57K		52,583	49,035	51,790	42,066	43,118	41,541	41,623	5ME	2ME, 3ME, 4ME, AF, 5SH, 15D, 25D, 40D, 60D, 120D, WSN
Q8	30K	398	47,130	43,702	46,157	37,704	38,647	37,233	37,307	5ME, 5SH, 15D, 25D, 40D, 60D, 120D, WSN	2ME, 3ME, 4ME, AF
	40K		49,654	46,245	48,843	39,723	40,716	39,227	39,305	5ME	2ME, 3ME, 4ME, AF, 5SH, 15D, 25D, 40D, 60D, 120D, WSN
	50K		39,894	37,426	39,529	31,915	32,713	31,516	31,579	2ME, 3ME, 4ME, AF, 5SH, 15D, 25D, 40D, 60D, 120D, WSN	N/A
	57K		50,628	47,212	49,865	40,503	41,515	39,996	40,076	5ME	2ME, 3ME, 4ME, AF, 5SH, 15D, 25D, 40D, 60D, 120D, WSN
Q7	30K	377	44,792	41,534	43,867	35,834	36,730	35,386	35,456	5ME, 5SH, 15D, 25D, 40D, 60D, 120D, WSN	2ME, 3ME, 4ME, AF
	40K		47,191	43,951	46,420	37,752	38,696	37,281	37,355	5ME	2ME, 3ME, 4ME, AF, 5SH, 15D, 25D, 40D, 60D, 120D, WSN
	50K		37,915	35,569	37,568	30,332	31,090	29,953	30,012	2ME, 3ME, 4ME, AF, 5SH, 15D, 25D, 40D, 60D, 120D, WSN	N/A
	57K		48,117	44,870	47,391	38,493	39,456	38,012	38,088	5ME	2ME, 3ME, 4ME, AF, 5SH, 15D, 25D, 40D, 60D, 120D, WSN
Q6	30K	355	43,354	40,200	42,458	34,683	35,550	34,249	34,317	5ME, 5SH, 15D, 25D, 40D, 60D, 120D, WSN	2ME, 3ME, 4ME, AF
	40K		45,675	42,540	44,929	36,540	37,453	36,083	36,155	5ME	2ME, 3ME, 4ME, AF, 5SH, 15D, 25D, 40D, 60D, 120D, WSN
	50K		36,697	34,427	36,361	29,357	30,091	28,991	29,048	2ME, 3ME, 4ME, AF, 5SH, 15D, 25D, 40D, 60D, 120D, WSN	N/A
	57K		46,571	43,429	45,869	37,257	38,188	36,791	36,864	5ME	2ME, 3ME, 4ME, AF, 5SH, 15D, 25D, 40D, 60D, 120D, WSN
Q5	30K	324	39,702	36,813	38,882	31,761	32,555	31,364	31,427	5ME, 5SH, 15D, 25D, 40D, 60D, 120D, WSN	2ME, 3ME, 4ME, AF
	40K		41,827	38,956	41,145	33,462	34,298	33,044	33,109	5ME	2ME, 3ME, 4ME, AF, 5SH, 15D, 25D, 40D, 60D, 120D, WSN
	50K		33,606	31,527	33,298	26,885	27,557	26,548	26,601	2ME, 3ME, 4ME, AF, 5SH, 15D, 25D, 40D, 60D, 120D, WSN	N/A
	57K		42,648	39,771	42,005	34,119	34,972	33,692	33,759	5ME	2ME, 3ME, 4ME, AF, 5SH, 15D, 25D, 40D, 60D, 120D, WSN
Q4	30K	292	36,978	34,288	36,214	29,582	30,322	29,212	29,270	5ME, 5SH, 15D, 25D, 40D, 60D, 120D, WSN	2ME, 3ME, 4ME, AF
	40K		38,958	36,283	38,322	31,166	31,945	30,776	30,838	5ME	2ME, 3ME, 4ME, AF, 5SH, 15D, 25D, 40D, 60D, 120D, WSN
	50K		31,300	29,364	31,014	25,040	25,666	24,727	24,776	2ME, 3ME, 4ME, AF, 5SH, 15D, 25D, 40D, 60D, 120D, WSN	N/A
	57K		39,722	37,042	39,123	31,778	32,572	31,380	31,443	5ME	2ME, 3ME, 4ME, AF, 5SH, 15D, 25D, 40D, 60D, 120D, WSN
Q3	30K	261	33,210	30,794	32,524	26,568	27,232	26,236	26,288	5ME, 5SH, 15D, 25D, 40D, 60D, 120D, WSN	2ME, 3ME, 4ME, AF
	40K		34,988	32,586	34,417	27,991	28,690	27,641	27,696	5ME	2ME, 3ME, 4ME, AF, 5SH, 15D, 25D, 40D, 60D, 120D, WSN
	50K		28,111	26,372	27,854	22,489	23,051	22,207	22,252	2ME, 3ME, 4ME, AF, 5SH, 15D, 25D, 40D, 60D, 120D, WSN	N/A
	57K		35,675	33,268	35,137	28,540	29,253	28,183	28,239	5ME	2ME, 3ME, 4ME, AF, 5SH, 15D, 25D, 40D, 60D, 120D, WSN
Q2	30K	233	30,071	27,884	29,450	24,057	24,658	23,756	23,804	5ME, 5SH, 15D, 25D, 40D, 60D, 120D, WSN	2ME, 3ME, 4ME, AF
	40K		31,700	29,500	31,200	25,300	26,000	25,000	25,100	5ME	2ME, 3ME, 4ME, AF, 5SH, 15D, 25D, 40D, 60D, 120D, WSN
	50K		25,500	23,900	25,200	20,400	20,900	20,100	20,100	2ME, 3ME, 4ME, AF, 5SH, 15D, 25D, 40D, 60D, 120D, WSN	N/A
	57K		32,300	30,100	31,800	25,800	26,500	25,500	25,600	5ME	2ME, 3ME, 4ME, AF, 5SH, 15D, 25D, 40D, 60D, 120D, WSN
Q1	30K	208	27,225	25,244	26,662	21,780	22,324	21,507	21,550	5ME, 5SH, 15D, 25D, 40D, 60D, 120D, WSN	2ME, 3ME, 4ME, AF
	40K		28,682	26,714	28,214	22,946	23,520	22,659	22,704	5ME	2ME, 3ME, 4ME, AF, 5SH, 15D, 25D, 40D, 60D, 120D, WSN
	50K		23,044	21,619	22,834	18,436	18,896	18,205	18,241	2ME, 3ME, 4ME, AF, 5SH, 15D, 25D, 40D, 60D, 120D, WSN	N/A
	57K		29,245	27,272	28,804	23,396	23,981	23,104	23,150	5ME	2ME, 3ME, 4ME, AF, 5SH, 15D, 25D, 40D, 60D, 120D, WSN



Field Adjustable Output (Q9/Q8/Q7/Q6/Q5/Q4/Q3/Q2/Q1) Option Description:

The Field Adjustable Output option enables the OSQ High Output area luminaires to be tuned to the exact needs of a particular application through multiple levels of adjustment. When ordered with the Q option, the luminaire will be shipped from the factory at the selected Q setting and will be fully adjustable between the nine settings.

Q Option Power & Lumen Data – 65L

Q Option Setting	CCT	System Watts 120-480V	Lumen Values							Optics Qualified on DLC QPL	
			Asymmetric	5ME	5SH & Floods	2ME w/BLS	3ME w/BLS	4ME w/BLS	AF w/BLS	Standard	Premium
Q9 [Full Power]	30K	550	63,945	59,011	62,326	51,156	52,435	50,517	50,617	2ME, 3ME, 4ME, AF, 5ME, 5SH, 15D, 25D, 40D, 60D, 120D, WSN	N/A
	40K		67,369	62,445	65,953	53,895	55,243	53,222	53,327	5ME	2ME, 3ME, 4ME, AF, 5SH, 15D, 25D, 40D, 60D, 120D, WSN
	50K		53,848	49,959	52,766	43,078	44,155	42,540	42,625	2ME, 3ME, 4ME, AF, 5SH, 15D, 25D, 40D, 60D, 120D, WSN	N/A
	57K		68,691	63,751	67,332	54,953	56,327	54,266	54,374	5ME	2ME, 3ME, 4ME, AF, 5SH, 15D, 25D, 40D, 60D, 120D, WSN
Q8	30K	521	61,568	56,817	60,009	49,254	50,486	48,639	48,735	2ME, 3ME, 4ME, AF, 5ME, 5SH, 15D, 25D, 40D, 60D, 120D, WSN	N/A
	40K		64,865	60,124	63,501	51,892	53,189	51,243	51,345	5ME	2ME, 3ME, 4ME, AF, 5SH, 15D, 25D, 40D, 60D, 120D, WSN
	50K		51,846	48,102	50,804	41,477	42,514	40,959	41,040	2ME, 3ME, 4ME, AF, 5SH, 15D, 25D, 40D, 60D, 120D, WSN	N/A
	57K		66,137	61,381	64,829	52,910	54,233	52,249	52,353	5ME	2ME, 3ME, 4ME, AF, 5SH, 15D, 25D, 40D, 60D, 120D, WSN
Q7	30K	493	58,513	53,999	57,032	46,811	47,981	46,226	46,318	2ME, 3ME, 4ME, AF, 5ME, 5SH, 15D, 25D, 40D, 60D, 120D, WSN	N/A
	40K		61,647	57,141	60,351	49,317	50,550	48,701	48,798	5ME	2ME, 3ME, 4ME, AF, 5SH, 15D, 25D, 40D, 60D, 120D, WSN
	50K		49,274	45,715	48,284	39,419	40,405	38,927	39,004	2ME, 3ME, 4ME, AF, 5SH, 15D, 25D, 40D, 60D, 120D, WSN	N/A
	57K		62,856	58,336	61,613	50,285	51,542	49,657	49,755	5ME	2ME, 3ME, 4ME, AF, 5SH, 15D, 25D, 40D, 60D, 120D, WSN
Q6	30K	465	56,634	52,264	55,200	45,307	46,440	44,741	44,830	2ME, 3ME, 4ME, AF, 5ME, 5SH, 15D, 25D, 40D, 60D, 120D, WSN	N/A
	40K		59,667	55,306	58,413	47,733	48,927	47,137	47,231	5ME	2ME, 3ME, 4ME, AF, 5SH, 15D, 25D, 40D, 60D, 120D, WSN
	50K		47,692	44,247	46,733	38,153	39,107	37,676	37,751	2ME, 3ME, 4ME, AF, 5SH, 15D, 25D, 40D, 60D, 120D, WSN	N/A
	57K		60,838	56,462	59,634	48,670	49,887	48,062	48,157	5ME	2ME, 3ME, 4ME, AF, 5SH, 15D, 25D, 40D, 60D, 120D, WSN
Q5	30K	424	51,864	47,862	50,550	41,491	42,528	40,972	41,054	2ME, 3ME, 4ME, AF, 5ME, 5SH, 15D, 25D, 40D, 60D, 120D, WSN	N/A
	40K		54,641	50,647	53,492	43,713	44,805	43,166	43,252	5ME	2ME, 3ME, 4ME, AF, 5SH, 15D, 25D, 40D, 60D, 120D, WSN
	50K		43,674	40,520	42,797	34,939	35,813	34,503	34,571	2ME, 3ME, 4ME, AF, 5SH, 15D, 25D, 40D, 60D, 120D, WSN	N/A
	57K		55,713	51,706	54,611	44,570	45,685	44,013	44,101	5ME	2ME, 3ME, 4ME, AF, 5SH, 15D, 25D, 40D, 60D, 120D, WSN
Q4	30K	383	48,305	44,578	47,082	38,644	39,610	38,161	38,237	2ME, 3ME, 4ME, AF, 5ME, 5SH, 15D, 25D, 40D, 60D, 120D, WSN	N/A
	40K		50,892	47,172	49,822	40,713	41,731	40,204	40,284	5ME	2ME, 3ME, 4ME, AF, 5SH, 15D, 25D, 40D, 60D, 120D, WSN
	50K		40,678	37,740	39,860	32,542	33,356	32,135	32,199	2ME, 3ME, 4ME, AF, 5SH, 15D, 25D, 40D, 60D, 120D, WSN	N/A
	57K		51,890	48,159	50,864	41,512	42,550	40,993	41,075	5ME	2ME, 3ME, 4ME, AF, 5SH, 15D, 25D, 40D, 60D, 120D, WSN
Q3	30K	344	43,383	40,036	42,285	34,707	35,574	34,273	34,341	2ME, 3ME, 4ME, AF, 5ME, 5SH, 15D, 25D, 40D, 60D, 120D, WSN	N/A
	40K		45,706	42,366	44,746	36,565	37,479	36,108	36,180	5ME	2ME, 3ME, 4ME, AF, 5SH, 15D, 25D, 40D, 60D, 120D, WSN
	50K		36,533	33,895	35,799	29,226	29,957	28,861	28,919	2ME, 3ME, 4ME, AF, 5SH, 15D, 25D, 40D, 60D, 120D, WSN	N/A
	57K		46,603	43,252	45,681	37,283	38,215	36,817	36,890	5ME	2ME, 3ME, 4ME, AF, 5SH, 15D, 25D, 40D, 60D, 120D, WSN
Q2	30K	304	39,283	36,252	38,288	31,426	32,212	31,034	31,095	2ME, 3ME, 4ME, AF, 5ME, 5SH, 15D, 25D, 40D, 60D, 120D, WSN	N/A
	40K		41,387	38,362	40,517	33,109	33,937	32,695	32,760	5ME	2ME, 3ME, 4ME, AF, 5SH, 15D, 25D, 40D, 60D, 120D, WSN
	50K		33,080	30,691	32,416	26,464	27,126	26,133	26,185	2ME, 3ME, 4ME, AF, 5SH, 15D, 25D, 40D, 60D, 120D, WSN	N/A
	57K		42,199	39,164	41,364	33,759	34,603	33,337	33,403	5ME	2ME, 3ME, 4ME, AF, 5SH, 15D, 25D, 40D, 60D, 120D, WSN
Q1	30K	269	35,564	32,820	34,664	28,452	29,163	28,096	28,152	2ME, 3ME, 4ME, AF, 5ME, 5SH, 15D, 25D, 40D, 60D, 120D, WSN	N/A
	40K		37,469	34,730	36,681	29,975	30,724	29,600	29,659	5ME	2ME, 3ME, 4ME, AF, 5SH, 15D, 25D, 40D, 60D, 120D, WSN
	50K		29,949	27,786	29,347	23,959	24,558	23,660	23,707	2ME, 3ME, 4ME, AF, 5SH, 15D, 25D, 40D, 60D, 120D, WSN	N/A
	57K		38,204	35,457	37,448	30,563	31,327	30,181	30,241	5ME	2ME, 3ME, 4ME, AF, 5SH, 15D, 25D, 40D, 60D, 120D, WSN

© 2018 Cree, Inc. and/or one of its subsidiaries. All rights reserved. For informational purposes only. Content is subject to change. Patent www.cree.com/patents. Cree®, the Cree logo, NanoOptic®, TrueWhite®, Cree TrueWhite®, and Colorfast DeltaGuard® are registered trademarks, and the Cree TrueWhite Technology logo, Automotive FrontlineOptic™, Precision Delivery Grid™ and OSQ™ are trademarks of Cree, Inc. The UL logo is a registered trademark of UL LLC. NEMA® is a registered trademark of the National Electrical Manufacturers Association. The DLC QPL logo and the DLC QPL Premium logo are registered trademarks of Efficiency Forward, Inc.

