

STANDARD UNDERDRAIN

NOTES:

1. PERFORATIONS TO BE PLACED UP OR DOWN AS SPECIFIED BY THE ENGINEER
2. HOLES ARE TO BE 1/2" DIA. OR 5/8" DIA.
3. PIPE SHALL BE MIN. 6" DIA.
4. SLOTTED REINFORCED CONC. PIPE (SRCP) CAN BE USED AS A COMBINED STORM AND UNDERDRAIN SYSTEM.
5. ALL UNDERDRAIN TO BE OUTLETTED DIRECTLY INTO A CATCH BASIN. THE TOP OF THE UNDERDRAIN PIPE IS TO MATCH THE TOP OF THE OUTLET PIPE.
6. INCLUDE CLEANOUTS AT SPACING NOT TO EXCEED 150 FEET.

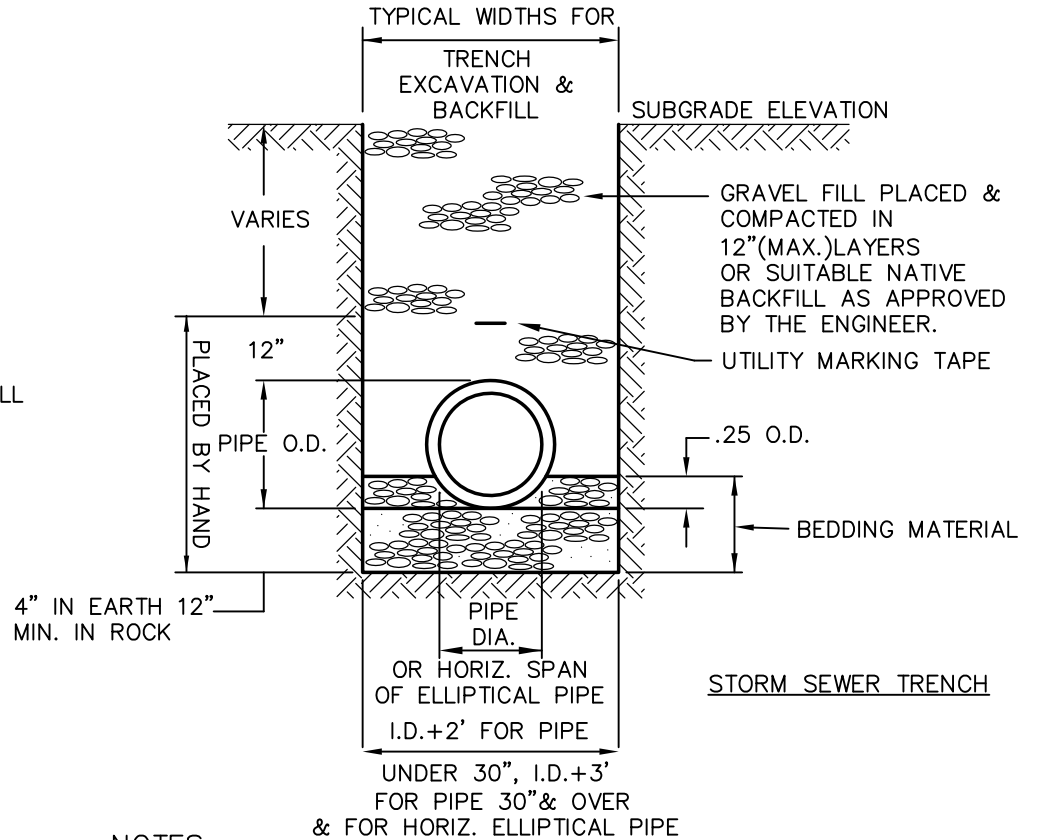

STORM SEWER TRENCH

NOTES:

1. ALL STORM DRAIN INSTALLED WITHIN TOWN RIGHT-OF-WAY SHALL BE CONCRETE PIPE. ALL CONCRETE PIPE SHALL BE MINIMUM CLASS IV UNLESS OTHERWISE SPECIFIED.
2. USE WATERTIGHT RUBBER GASKETS IN ALL PIPE JOINTS.
3. PIPE BEDDING MATERIALS SHALL BE SAND OR SANDY SOIL, ALL OF WHICH PASSES 3/8" SIEVE AND <10% PASSING NO. 200 SIEVE.
4. WHEN GROUND WATER IS ENCOUNTERED, 3/4" STONE SHALL BE SUBSTITUTED FOR PIPE BEDDING, AND BACKFILLED TO 12" ABOVE THE TOP OF PIPE.



SCALE : NONE
DRAWN BY: SR
CHECKED BY: SMB
APPROVED BY: DAP
LAST REVISED: 9/1/2016



TOWN OF GLASTONBURY
DEPARTMENT OF PHYSICAL SERVICES
ENGINEERING DIVISION

TRENCH FOR STORM DRAIN
AND UNDER DRAIN

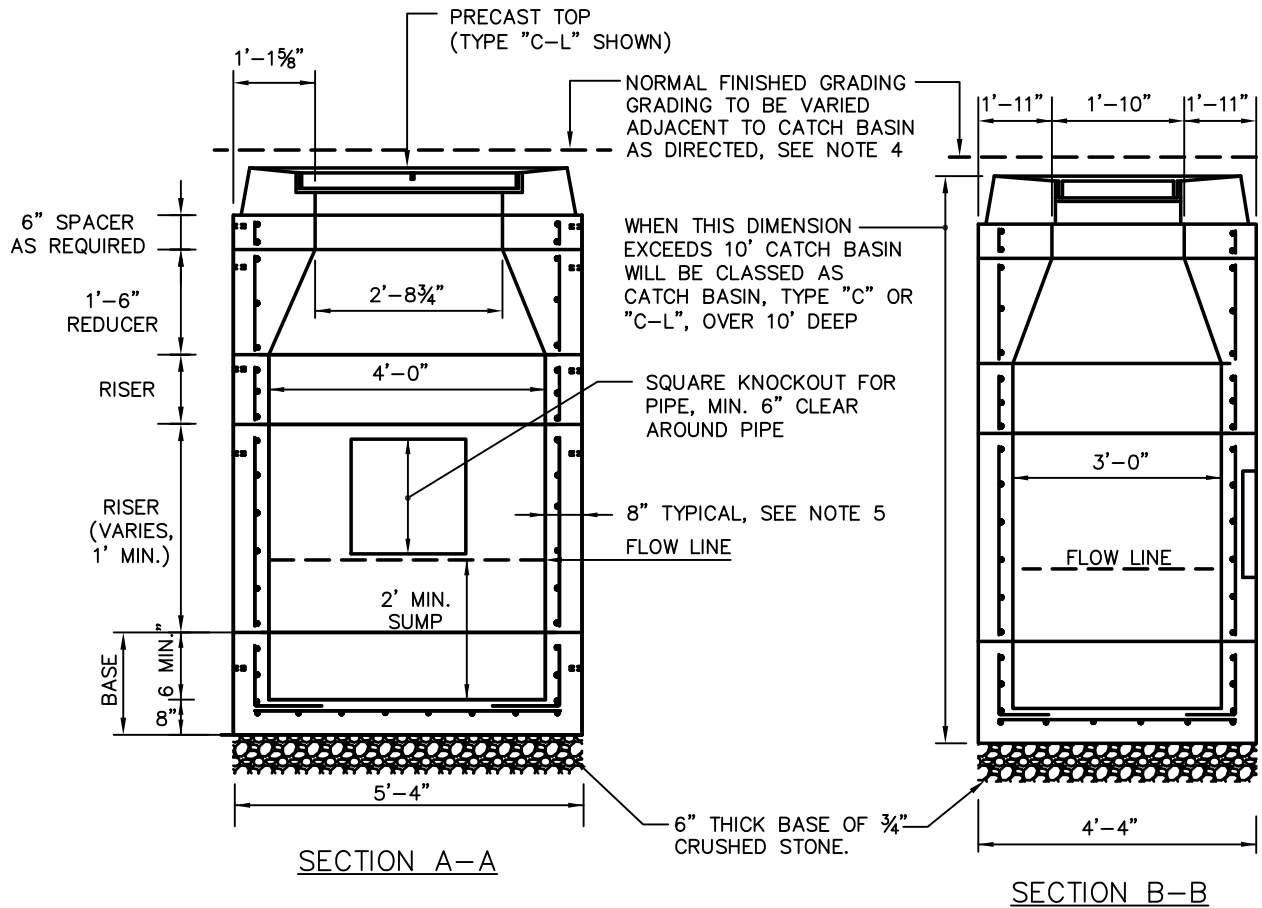

NOTES

- ALL CATCH BASINS SHALL CONFORM TO CONNDOT STANDARD DETAIL SHEETS HW-507_1 AND HW-507_04 EXCEPT AS OTHERWISE NOTED ON THIS DETAIL. DOUBLE GRATE CATCH BASINS SHALL CONFORM TO CONNDOT STANDARD SHEETS HW-507_05 AND HW-507_06.
- PRECAST CATCH BASIN TOPS MUST BE PROPERLY ALIGNED AS SHOWN AND SHALL CONFORM TO CONNDOT STANDARD DETAIL SHEETS HW-507_07. CAPE COD CATCH BASIN TOPS SHALL HAVE AN OPEN THROAT.
- ALL FRAMES AND GRATES SHALL BE GALVANIZED. FOR DETAILS OF FRAMES AND GRATES, SEE CONNDOT STANDARD DETAIL SHEET HW-507_08.
- WHEN TYPE 'C' CATCH BASINS ARE CONSTRUCTED IN PAVEMENT, THE NORMAL GUTTER OF THE ROADWAY SHALL BE VARIED TO PROVIDE AN ADDITIONAL 2-INCH DEPRESSED GUTTER AT THE CATCH BASIN.
- WALL THICKNESS TO BE 12 INCHES WHEN HEIGHT OF STRUCTURE EXCEEDS 10 FEET FROM TOP OF FRAME TO BOTTOM OF BASE. THICKER WALLS APPLY ONLY TO PORTION OF STRUCTURE BELOW 10' DEEP.
- PRECAST RISER SECTIONS SHALL NEVER HAVE CORNER PIPE ENTRIES. WHEN PIPE ALIGNMENT CANNOT BE CHANGED, A ROUND STRUCTURE SHALL BE USED PER CONNDOT DETAIL HW-507_04.
- CATCH BASINS LEFT ABOVE THE FINISHED GUTTER GRADE FOR THE WINTER MUST BE PROPERLY SHIMMED FOR PLOWING AS SHOWN IN PLATE 4.
- MORTAR MIX SHALL NOT CONTAIN LIME.
- ENDS OF PIPE SHALL BE SAWCUT FLUSH WITH INSIDE WALLS.
- IF CONCRETE MASONRY UNITS ARE USED THE FOLLOWING ADDITIONAL REQUIREMENTS SHALL BE MET:
 - MAXIMUM CORBEL SHALL NOT EXCEED 2 INCHES;
 - WHERE NECESSARY, BLOCKS MAY BE CUT OR CONCRETE BRICK USED (NO RED BRICK PERMITTED);
 - CORNERS SHALL BE SQUARE, COURSES LEVEL, AND JOINTS PROPERLY STAGGERED;
 - VOIDS IN EXTERIOR WALLS SHALL BE GROUTED, AND CORBELS SHALL BE WEDGED.

SCALE : NONE
DRAWN BY: SR
CHECKED BY: SMB
APPROVED BY: DAP
LAST REVISED: 9/1/2016

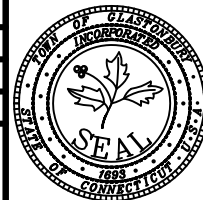

TOWN OF GLASTONBURY
DEPARTMENT OF PHYSICAL SERVICES
ENGINEERING DIVISION

CATCH BASIN

H:\DWG\Details\TOG\Standard Detail Plates\Plate22-Sedstructure.dwg

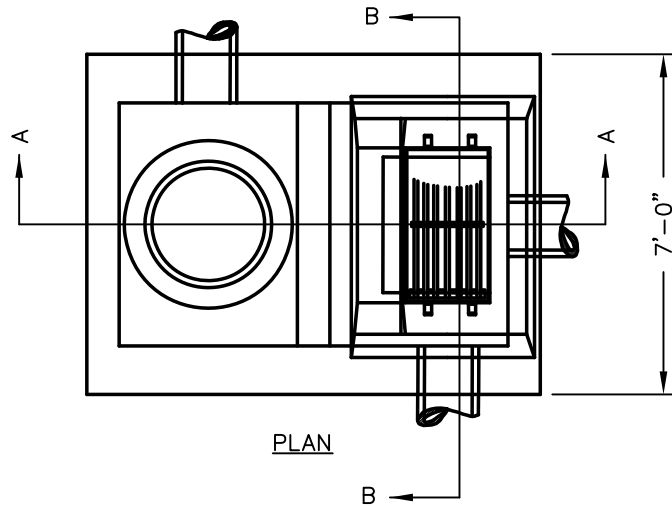

NOTES:

1. BAFFLE CONSTRUCTION TO BE OF CAST MATERIAL WITH THRU HOLES ABOVE OUTLET FLOW LINE OR MORTARED CEMENT BLOCKS WITH WEEP HOLES ABOVE OUTLET FLOW LINE.
2. ADJUST M.H. FRAME TO SUIT REQUIRED FIELD HEIGHT.
3. CONSTRUCTION JOINT - SEALED WITH 1" DIA. BUTYL RUBBER OR ACCEPTABLE EQUIVALENT
4. DESIGN LOADING - AASHTO HS20-44.
5. STEEL REINFORCEMENT - ASTM A-615-75, GRADE 60, 2" MIN. COVER.
6. CONCRETE MINIMUM STRENGTH - 5,000 P.S.I. @ 28 DAYS.
7. MAXIMUM HEIGHT OF EACH ADDITIONAL PIECE 4'-0".
8. MAXIMUM INSIDE HEIGHT FOR 2 PIECE CHAMBER 8'-0".
9. ROOF AND SIDE WALL OPENINGS AS SPECIFIED.
10. STRUCTURE TO BE INSTALLED IN AN "OFFLINE" CONFIGURATION WITH DIVERSION MANHOLES AS PER TOWN PUBLIC IMPROVEMENT STANDARDS.

HEAVY DUTY M.H. COVER EMBOSSED WITH "STORM" OR "DRAIN", SEE PLATE 33

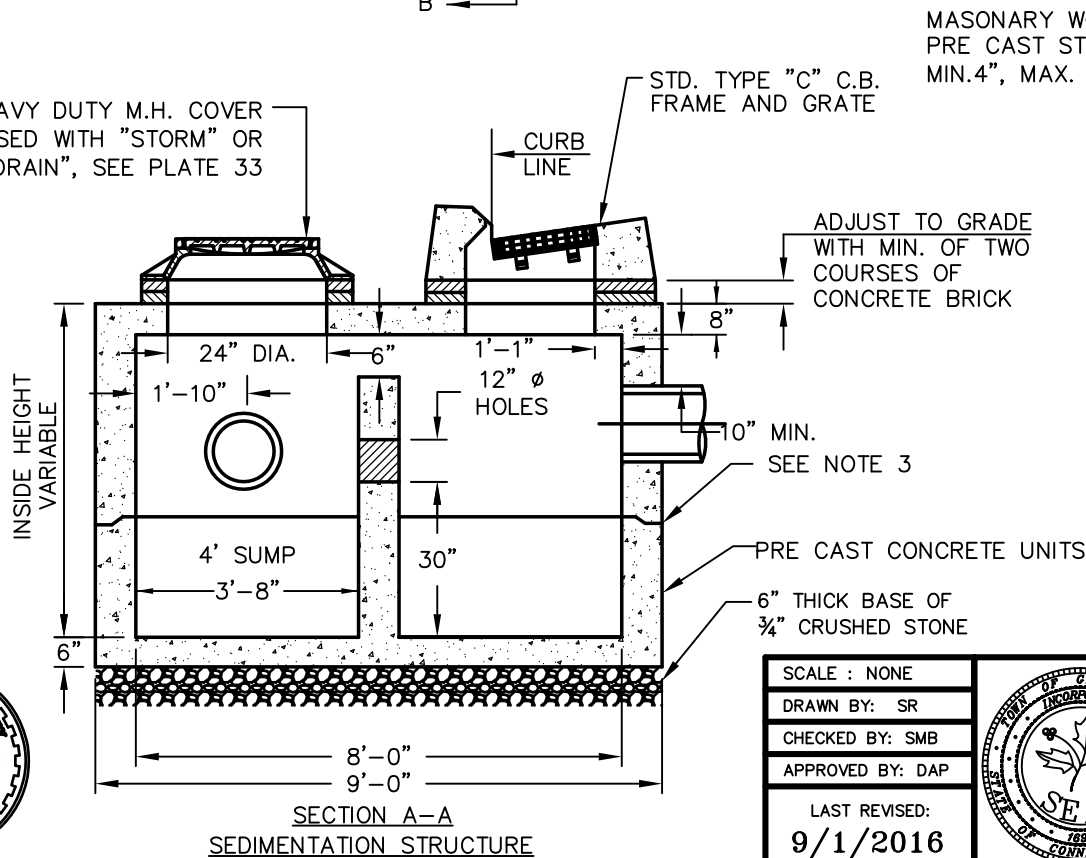

MASONRY WORK ABOVE PRE CAST STRUCTURE TOP MIN. 4", MAX. 18"

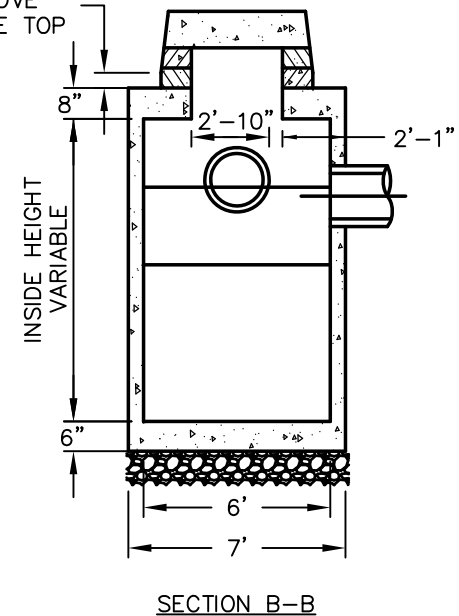

SCALE : NONE
DRAWN BY: SR
CHECKED BY: SMB
APPROVED BY: DAP
LAST REVISED: 9/1/2016



TOWN OF GLASTONBURY
DEPARTMENT OF PHYSICAL SERVICES
ENGINEERING DIVISION

**SEDIMENTATION
STRUCTURE**

PLATE NO. 22

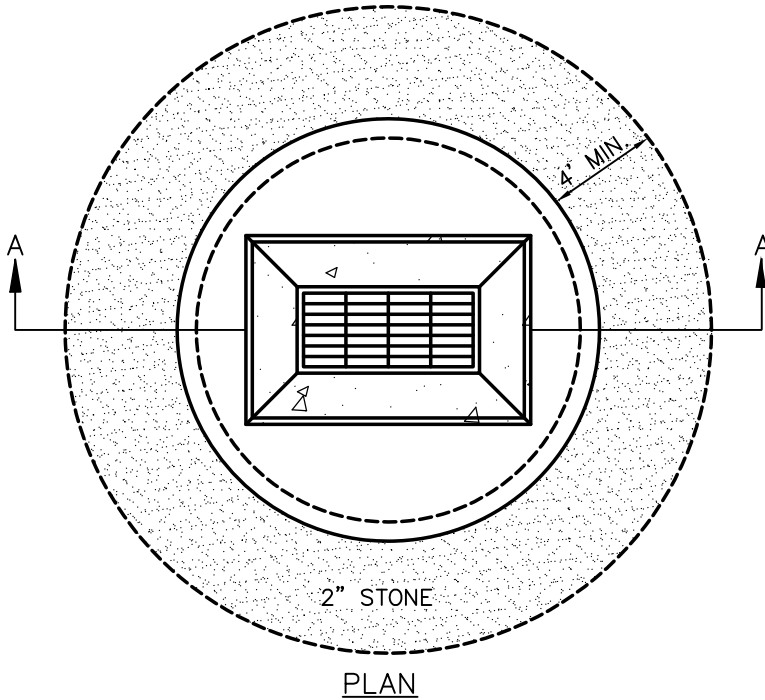

NOTES:

1. DRYWELLS SHALL BE CONSTRUCTED WITH AN OVERFLOW SYSTEM CONNECTED TO A STORM DRAIN SYSTEM.
2. THE DRYWELL WILL BE SIZED BY THE DESIGN ENGINEER TO PROVIDE THE REQUIRED VOLUME OF STORAGE.
3. PERC. TESTS ARE REQUIRED AT LOCATIONS OF PROPOSED DRY WELLS, TO DETERMINE SOIL PERMEABILITY AND WATER TABLE ELEVATION.

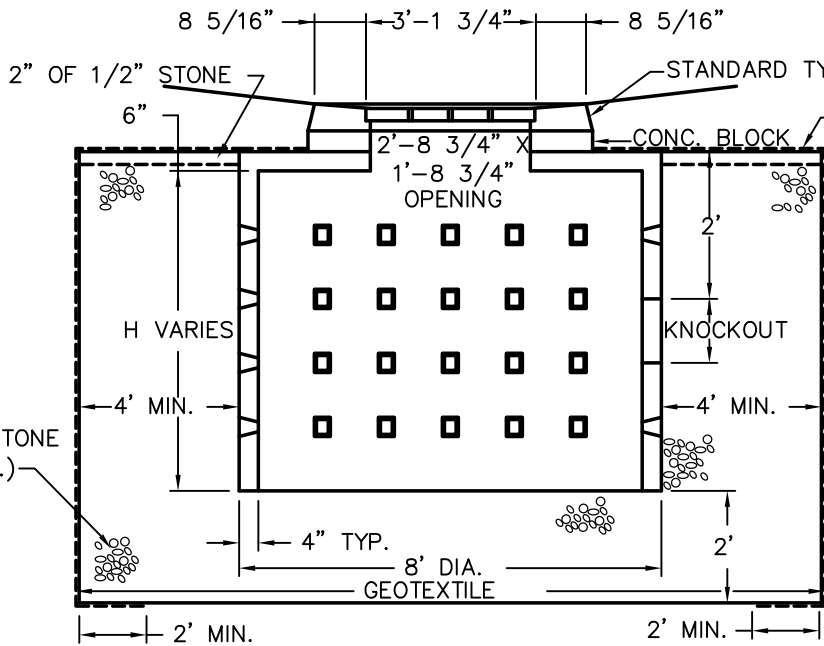

GEOTEXTILE (SUBSURFACE DRAINAGE CLASS A) TO BE WRAPPED AROUND ENTIRE DRY WELL

H	STORAGE CAPACITY CU. FT.	VOLUME DRY WELL CU. FT.
6' - 0"	645	253
8' - 0"	821	338
10' - 0"	995	422

NOTES:

1. CONC. MIN. STRENGTH-5000 P.S.I. AT 28 DAYS.
2. STEEL REINF. ASTM-A-615-68 GRADE 60, 1" MIN. COVER.
3. DESIGN LOADING-STANDARD UNITS: AASHTO-HS20-44.
4. VOIDS IN STONE ASSUMED TO BE 0.3 OF TOTAL VOLUME OF STONE.
5. KNOCKOUT SHALL BE PROPERLY SIZED FOR INLET PIPE.

SECTION A - A

H:\DWG\Details\TOG\Standard Detail Plates\Plate23-Drywell.dwg



SCALE : NONE
DRAWN BY: SR
CHECKED BY: SMB
APPROVED BY: DAP
LAST REVISED: 9/1/2016



**TOWN OF GLASTONBURY
DEPARTMENT OF PHYSICAL SERVICES
ENGINEERING DIVISION**

**PRECAST CONCRETE
DRYWELL**

NOTES:

1. FOOTING BASE MAY BE CONSTRUCTED OF POURED IN PLACE CONCRETE OR PRECAST C.B. BLOCKS SET LEVEL WITH FULL MORTARED JOINTS.
2. THE FOOTING SHALL BE USED ON BOTH INLET AND OUTLET SECTIONS, THE PRIME FUNCTION IS TO PREVENT EROSION AND SETTLEMENT.

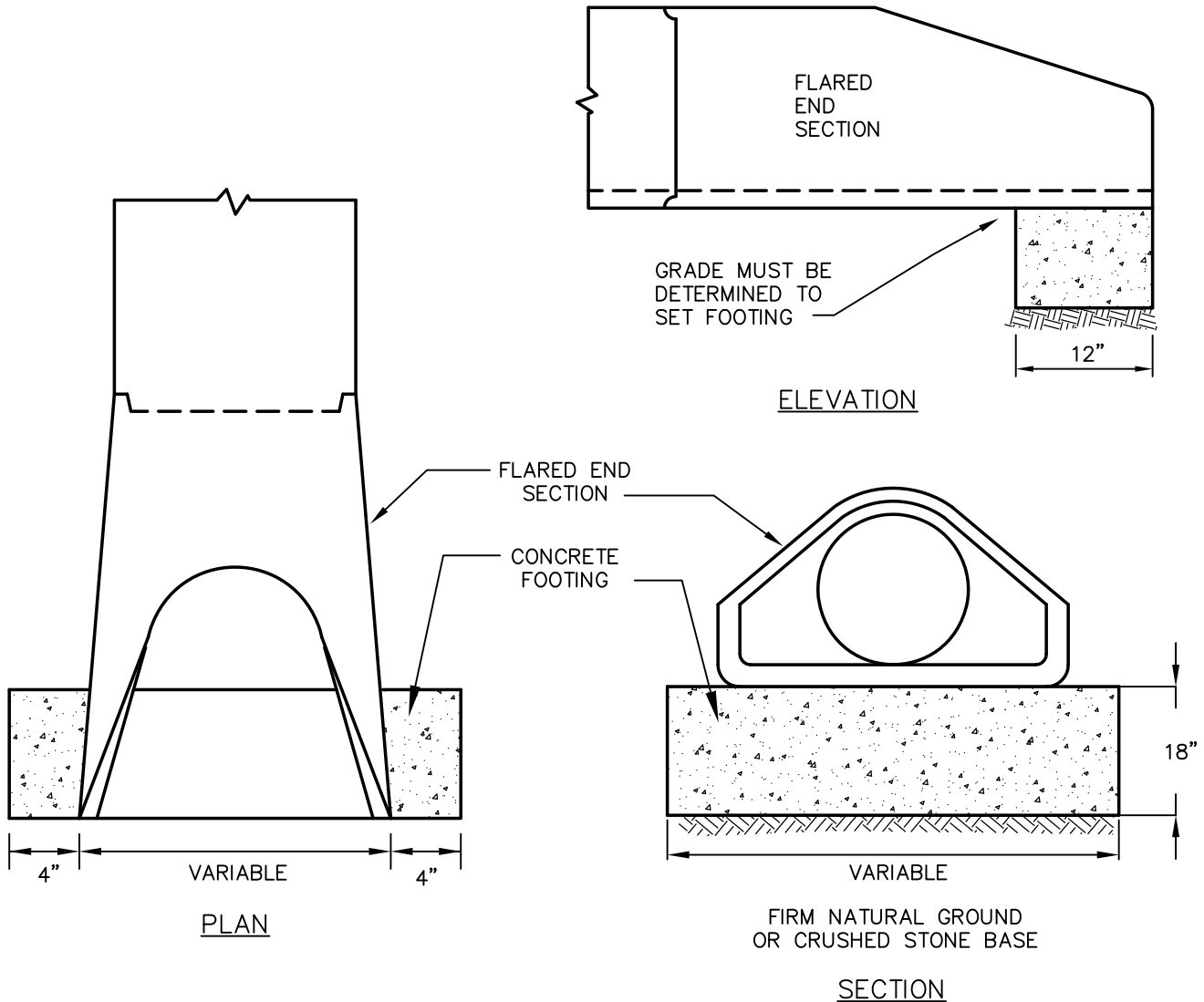

H:\DWG\Details\TOG\Standard Detail Plates\Plate24--FootingsForFlaredEnd.dwg



SCALE : NONE
DRAWN BY: SR
CHECKED BY: SMB
APPROVED BY: DAP
LAST REVISED: 4/29/2008



TOWN OF GLASTONBURY
DEPARTMENT OF PHYSICAL SERVICES
ENGINEERING DIVISION

**CONCRETE FOOTING FOR
FLARED END SECTION**

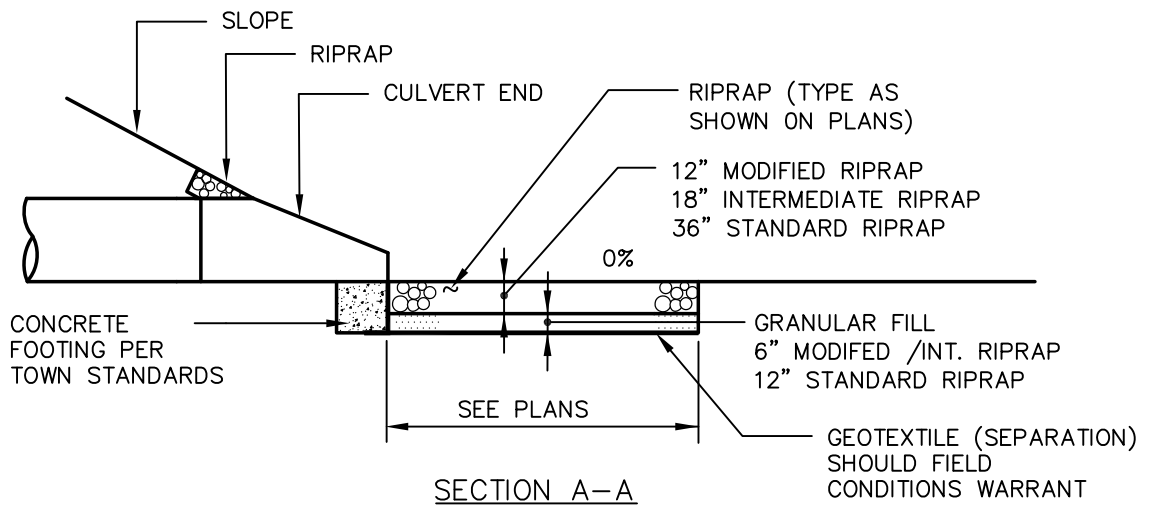
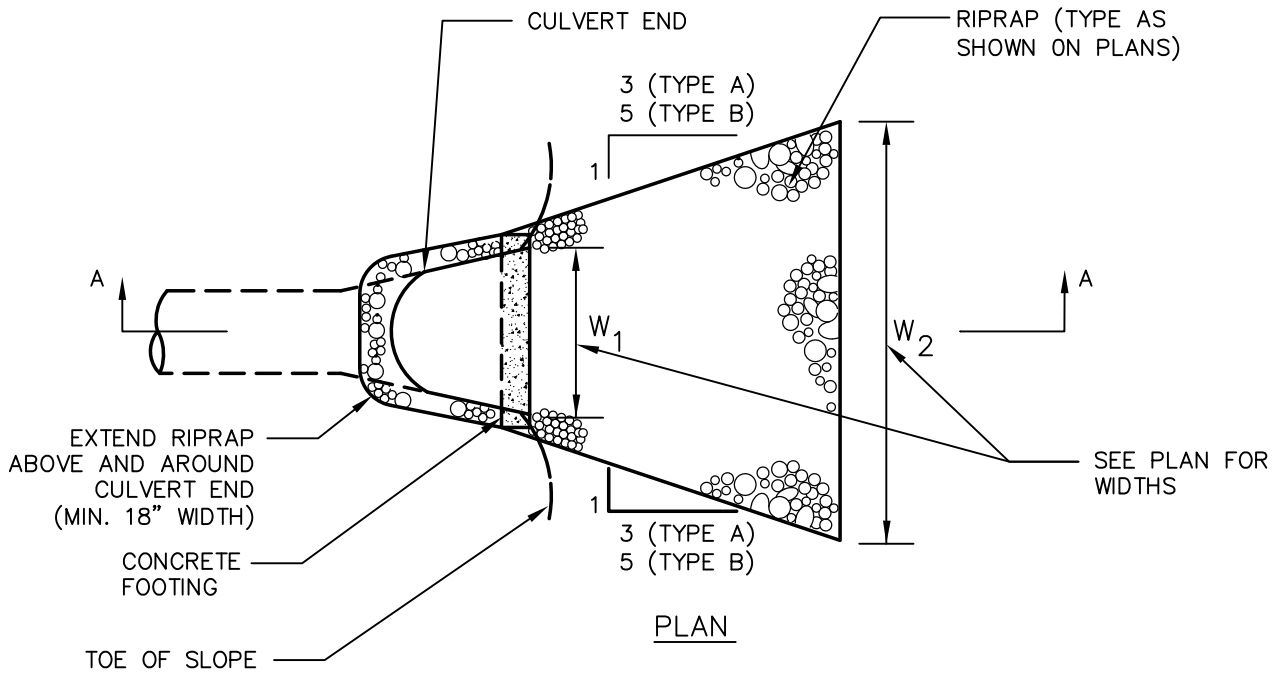

RIPRAP SPECIFICATION

OUTLET VELOCITY	RIPRAP TYPE
0-8 FPS	MODIFIED
8-10 FPS	INTERMEDIATE
10-14 FPS	STANDARD

NOTES:

1. DETAIL TO BE USED FOR OUTFALLS WHERE NO WELL DEFINED CHANNEL EXISTS.
2. APRON DIMENSIONS TO BE COMPUTED PER SECTION 11.13 OF CONNDOT DRAINAGE MANUAL.
3. TYPE B SHALL BE USED FOR LOCATIONS WHERE TAILWATER > 1/2 PIPE DIAMETER.

H:\DWG\Details\TOG\Standard Detail Plates\Plate25-RipRapApronTypeA&B.dwg



SCALE : NONE
DRAWN BY: SR
CHECKED BY: SMB
APPROVED BY: DAP
LAST REVISED: 9/1/2016



**TOWN OF GLASTONBURY
DEPARTMENT OF PHYSICAL SERVICES
ENGINEERING DIVISION**

**RIPRAP APRON
TYPE A AND TYPE B**

H:\DWG\Details\TOG\Standard Detail Plates\RipRapApronTypeC.dwg

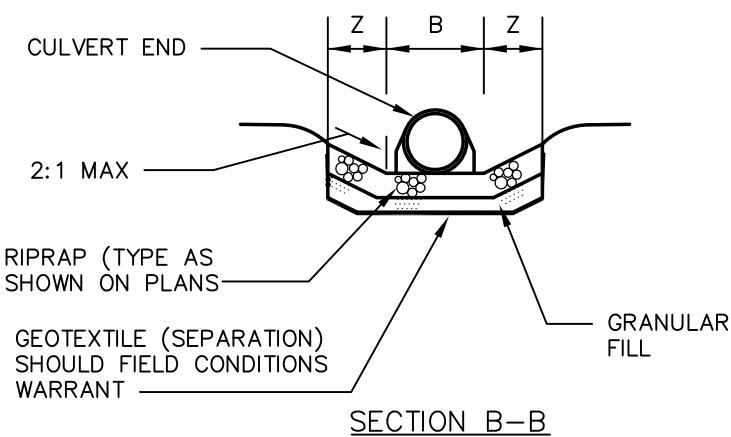
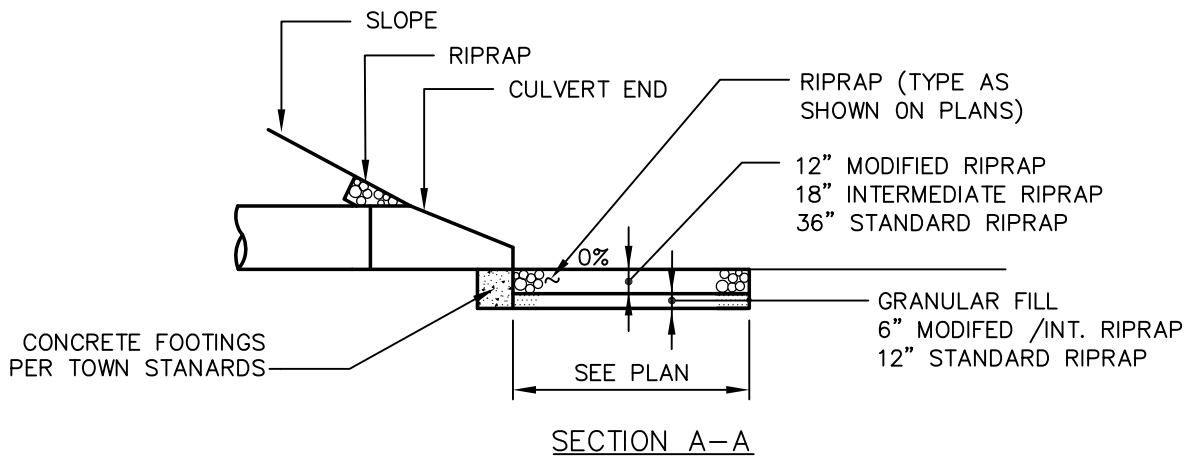
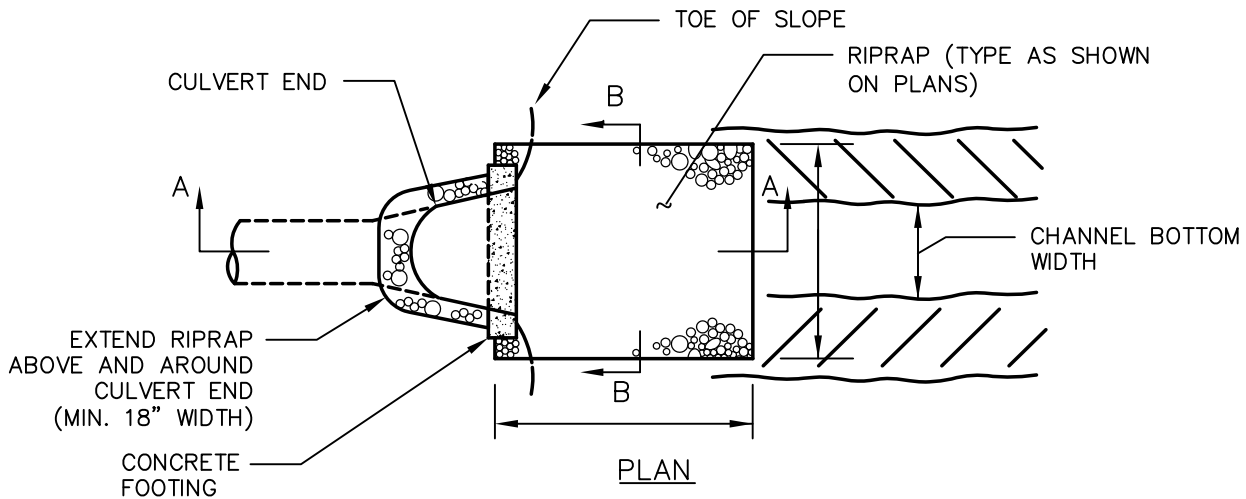

TYPE C RIPRAP APRON

NOTES:

1. DETAIL TO BE USED FOR OUTFALL LOCATIONS WITH A WELL DEFINED CHANNEL DOWNSTREAM OF THE OUTFALL.
2. APRON DIMENSIONS SHALL BE COMPUTED PER SECTION 11.13 OF THE CONDOT DRAINAGE MANUAL.

RIPRAP SPECIFICATION

OUTLET VELOCITY	RIPRAP TYPE
0-8 FPS	MODIFIED
8-10 FPS	INTERMEDIATE
10-14 FPS	STANDARD



SCALE : NONE
 DRAWN BY: SR
 CHECKED BY: SMB
 APPROVED BY: DAP
 LAST REVISED:
9/1/2016



**TOWN OF GLASTONBURY
 DEPARTMENT OF PHYSICAL SERVICES
 ENGINEERING DIVISION**

**RIPRAP APRON
 TYPE C**

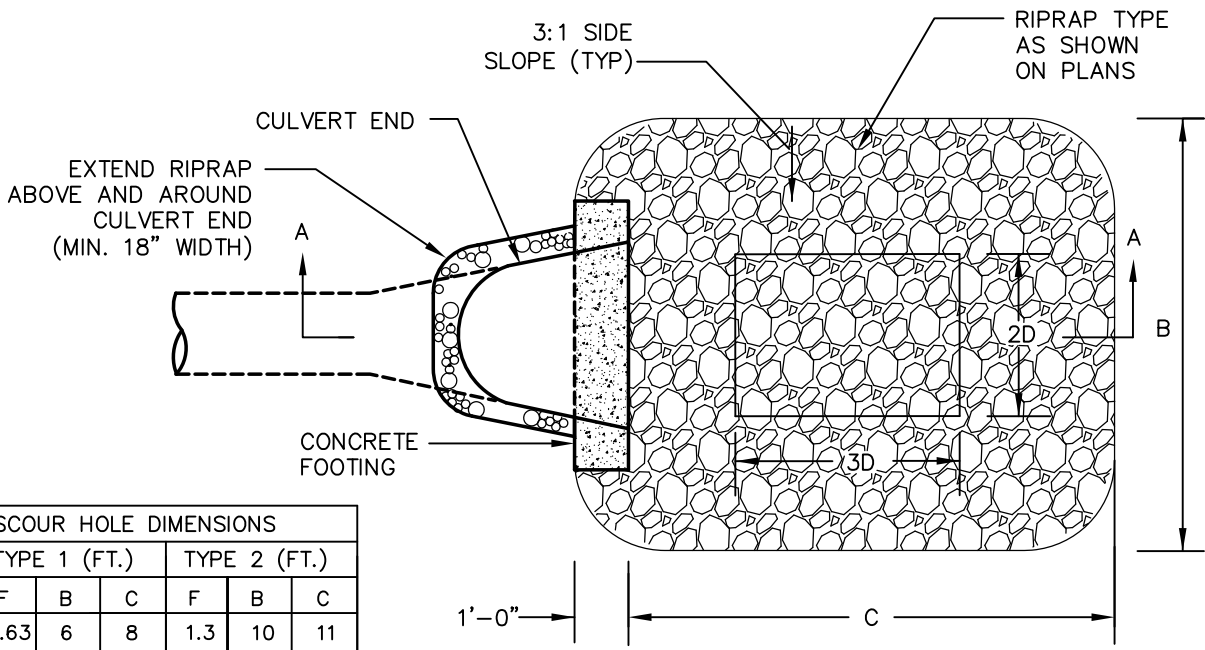

SCOUR HOLE DIMENSIONS						
(IN.)	TYPE 1 (FT.)			TYPE 2 (FT.)		
D	F	B	C	F	B	C
15	0.63	6	8	1.3	10	11
18	0.75	8	9	1.5	12	14
24	1.00	10	12	2.0	16	18
30	1.25	13	15	2.5	20	23
36	1.50	15	18	3.0	24	27
42	1.75	18	21	3.5	28	32
48	2.00	20	24	4.0	32	36
54	2.25	23	27	4.5	36	41
60	2.50	25	30	5.0	40	45

PLAN VIEW

NOTES:

1. DETAIL TO BE USED IN LOCATIONS WHERE FLOWS EXCEED CAPACITY OF RIPRAP APRONS AS PER CONNDOT DRAINAGE MANUAL.
2. RIPRAP SIZE SHALL BE COMPUTED ACCORDING TO CONNDOT DRAINAGE MANUAL SECTION 11.13.

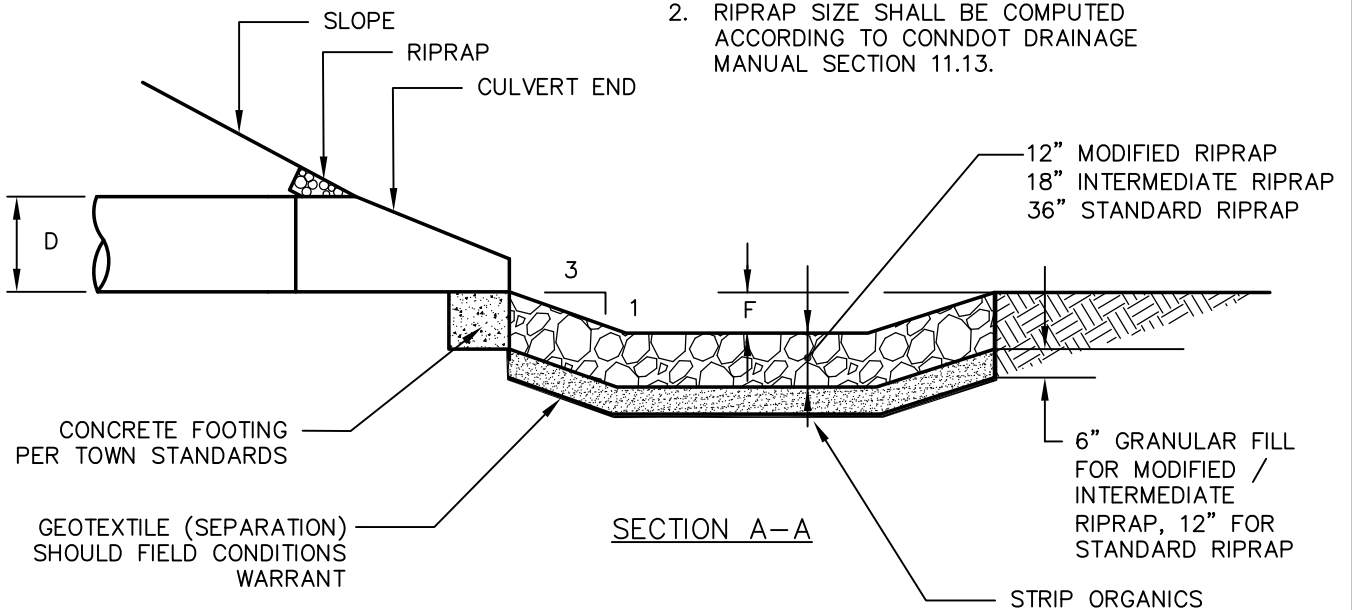

H:\DWG\Details\TOG\Standard Detail Plates\Plate27-ScourHole.dwg



SCALE : NONE
DRAWN BY: SR
CHECKED BY: SMB
APPROVED BY: DAP
LAST REVISED: 9/1/2016



TOWN OF GLASTONBURY
DEPARTMENT OF PHYSICAL SERVICES
ENGINEERING DIVISION

PREFORMED SCOUR HOLE
TYPE 1 & TYPE 2