

TOWN OF GLASTONBURY

INVITATION TO BID

<u>BID #</u>	<u>ITEM</u>	<u>DATE &amp; TIME REQUIRED</u>
GL-2014-28	Hebron Avenue and New London Turnpike Intersection Improvements	April 8, 2014 at 11:00 A.M.

The Town of Glastonbury is currently seeking bids for the installation of a new traffic control signal and other related roadway improvements at the intersection of Hebron Avenue and New London Turnpike.

Bid Forms, Plans, and Specifications may be obtained from the Town's website at [www.glastonbury-ct.gov](http://www.glastonbury-ct.gov) at no cost or at the Office of the Purchasing Agent, Town Hall, 2155 Main Street, Glastonbury, Connecticut 06033, (second level) for a non-refundable fee of \$100.

Prevailing Wages: The contractor must comply with Section 31-53 of the Connecticut General Statutes as amended, including annual adjustments in prevailing wages.

The Town reserves the right to waive informalities or reject any part of, or the entire bid, when said action is deemed to be in the best interests of the Town. All Sealed Bids must be submitted to the Office of the Purchasing Agent no later than the time and date indicated. All bids will be publicly opened and read.

The Town of Glastonbury is an Affirmative Action/Equal Opportunity Employer. Minority / Women / Disadvantaged Business Enterprises are encouraged to bid.

Mary F. Visone  
Purchasing Agent

**TABLE OF CONTENTS**

**SECTION**

[INFORMATION FOR BIDDERS](#)

IB

[GENERAL CONSTRUCTION SPECIFICATIONS](#)

GCS

[SPECIAL CONDITIONS](#)

SC

[BID PROPOSAL](#)

BP

[SPECIAL PROVISIONS](#)

SP

[ATTACHMENT A: PREVAILING WAGE INFORMATION](#)

[ATTACHMENT B: CONSTRUCTION PLANS](#)

1. Sealed bids (**one original and one copy**) on the attached Bid Forms will be received at the Office of the Purchasing Agent, Town Hall, 2155 Main Street, Glastonbury, Connecticut 06033 (second level). At the designated time of opening, they will be publicly opened, read, recorded and placed on file.
2. Whenever it is deemed to be in the best interest of the Town, the Town Manager, Purchasing Agent or designated representative shall waive informalities in any and all bids. The right is reserved to reject any bid, or any part of any bid, when such action is deemed to be in the best interest of the Town of Glastonbury.
3. The award will be on the basis of base bid total cost plus the sum of any alternates accepted by the Owner. Bidders shall submit a Bid for all of the items included in the Base Bid, and shall include a separate price of each alternate item described in the Bidding Documents as provided for in the Bid Proposal. The price for each alternate will be the amount added to or deleted from the Base Bid if the Owner selects the alternate.  
  
The bid total cost shall be arrived at by the mathematical calculation of the unit price multiplied times the number of units specified for each line item, and the total sum of all line items in the bid. In the event that the Town finds computational errors in a respondent's bid proposal, the bid total cost shall be recalculated by the Town based on the unit prices contained in the bid proposal.
4. Bids will be carefully evaluated as to conformance with stated specifications.
5. The envelope enclosing your bid should be clearly marked by bid number, time of bid opening, and date.
6. If a bid involves any exception from stated specifications, they must be clearly noted as exceptions, underlined, and attached to the bid.
7. The Bid Documents contain the provisions required for the requested item. Information obtained from an officer, agent, or employee of the Town or any other person shall not affect the risks or obligations assumed by the Bidder or relieve him/her from fulfilling any of the conditions of the bid.
8. Each Bidder is held responsible for the examination and/or to have acquainted themselves with any conditions at the job site which would affect their work before submitting a bid. Failure to meet this criteria shall not relieve the Bidder of the responsibility of completing the bid without extra cost to the Town of Glastonbury.
9. Any bid may be withdrawn prior to the above-scheduled time for the opening of bids or authorized postponement thereof. Any bid received after the time and date specified shall not be considered. No Bidder may withdraw a bid within sixty (60) days after the actual date of the opening thereof. Should there be reasons why a bid cannot be awarded within the specified period, the time may be extended by mutual agreement between the Town and the Bidder.
10. Each bid must be accompanied by a bid bond payable to the Town for ten percent (10%) of the total amount of the bid. The bid bond of the successful Bidder will be retained until the payment bond and performance bond have been executed and approved, after which it will be returned. A certified check may be used in lieu of a bid bond. The Town of Glastonbury will not be liable for the accrual of any interest on any certified check submitted. Cashier's checks will not be accepted.
11. A 100% Performance and Payment bond are required of the successful bidder. This bond shall cover all aspects of the specification and shall be delivered to the Purchasing Agent prior to the

issuance of a purchase order. The Performance and Payment Bond will be returned upon the delivery and acceptance of the bid items.

12. The Bidder agrees and warrants that in the submission of this sealed Bid, they will not discriminate or permit discrimination against any person or group of persons on the grounds of race, color, religion, national origin, sex, or physical disability including, but not limited to blindness, unless it is shown by such Bidder that such disability prevents performance of that which must be done to successfully fulfill the terms of this sealed Bid or in any manner which is prohibited by the laws of the United States or the State of Connecticut: and further agrees to provide the Human Relations Commission with such information requested by the Commission concerning the employment practices and procedures of the Bidder. An Affirmative Action Statement will be required by the successful Bidder.
13. Bidder agrees to comply with all of the latest Federal and State Safety Standards and Regulations and certifies that all work required in this bid will conform to and comply with said standards and regulations. Bidder further agrees to indemnify and hold harmless the Town for all damages assessed against the Town as a result of Bidder's failure to comply with said standards and/or regulations.
14. All correspondence regarding any purchase made by the Town of Glastonbury shall reference the Town's purchase order number. Each shipping container shall clearly indicate both Town purchase order number and item number.
15. Bidder is required to review the Town of Glastonbury Code of Ethics adopted July 8, 2003 and effective August 1, 2003. Bidder shall acknowledge that they have reviewed the document in the area provided on the bid/proposal response page (BP). The selected Bidder will also be required to complete and sign an Acknowledgement Form prior to award. The Code of Ethics and the Consultant Acknowledgement Form can be accessed at the Town of Glastonbury website at [www.glastonbury-ct.gov](http://www.glastonbury-ct.gov). Upon entering the website click on **Bids & RFPs** which will bring you to the links for the **Code of Ethics** and the **Consultant Acknowledgement Form**. If the Bidder does not have access to the internet, a copy of these documents can be obtained through the Purchasing Department at the address listed within this bid/proposal.
16. **Non-Resident Contractors:**  
  
Upon award the Town is required to report names of nonresident (out of state) Contractors to the State of Connecticut, Department of Revenue Services (DRS) to ensure that Employment Taxes and other applicable taxes are being paid by Contractors.  
  
**A single surety bond for 5% of the entire contract price is required to be filed with DRS by any unverified nonresident prime or general contractor (if awarded) where the contract price for the project is \$250,000 or more.** The contractor will be required to promptly furnish to the Town a copy of the **Form AU-968 - Certificate of Compliance** issued by the State of Connecticut, DRS. See State of Connecticut **Notice SN 2012 (2).**
17. Bidder shall include on a sheet(s) attached to its proposal a complete disclosure of all past and pending mediation, arbitration and litigation cases that the bidder or its principals (regardless of their place of employment) have been involved in for the most recent five years. Please include a statement of the issues in dispute and their resolution. Acceptability of Bidder based upon this disclosure shall lie solely with the Town.
18. Bidder or its principals, regardless of their place of employment, shall not have been convicted of, nor entered any plea of guilty, or nolo contendere, or otherwise have been found civilly liable or criminally responsible for any criminal offense or civil action. Bidder shall not be in violation of

any State or local ethics standards or other offenses arising out of the submission of bids or proposals, or performance of work on public works projects or contracts.

19. It is the responsibility of the bidder to check the Town's website before submitting bid for addendums posted prior to bid opening.

20. **Prevailing Wage Rates:**

Respondents shall comply with State Statutes concerning Employment and Labor Practices, if applicable, and Section 31-53 of the Connecticut General Statutes, as amended (Prevailing Wages). Wage Rate Determination for this project from the State of Connecticut is included in the Bid Documents. Certified payrolls for site labor shall be submitted weekly to the Town's Representative or his designee on the correct State of Connecticut form (see RFP). The Town reserves the right to, without prior notice, audit payroll checks given to workers on site in order to ascertain that wages and fringe benefits are being paid as required by the State of Connecticut. Please make special note of the State requirement to adjust wage and fringe benefit rates on each July 1st following the original published rates.

NOTE that respondent is to include in its proposal all costs required by such annual increases in the PREVAILING RATES. NO escalation clauses are to be included in the respondent's proposal and NO escalation clauses will be in the Contract Agreement. Respondent is to anticipate any future increases and include these costs in the proposal response.

Contractor's invoices will not be paid if certified payrolls are incomplete, incorrect or not received in a timely manner.

All Apprentices must be registered with the State of Connecticut and their number shall not exceed the number allowed by law. Otherwise, all workers must be paid at least the Journeyman rate listed including benefits.

OSHA SAFETY AND HEALTH CERTIFICATION

Effective July 1, 2009: Any Mechanic, Laborer, or Worker, who performs work in a classification listed on the prevailing wage rate schedule on any public works project covered under C.G.S. Section 31-53, both on site and on or in the public building, must have completed a federal OSHA Safety and Health course within the last 5 years.

21. Each bid shall also include a description of three (3) projects completed by the bidder with references to demonstrate successful experience with similar projects.

**IMPORTANT: Failure to comply with general rules may result in disqualification of the Bidder.**

**NOTE:** Any technical questions regarding this bid shall be made in writing (email acceptable) and directed to Stephen Braun, Assistant Town Engineer, 2155 Main Street, PO Box 6523, Glastonbury, CT 06033; [stephen.braun@glastonbury-ct.gov](mailto:stephen.braun@glastonbury-ct.gov). Telephone (860) 652-7743 between the hours of 8:00 a.m. – 4:30 p.m. For administrative questions concerning this bid/proposal, please contact Mary F. Visone, Purchasing Agent, at (860) 652-7588 or email the Purchasing Department at [purchasing@glastonbury-ct.gov](mailto:purchasing@glastonbury-ct.gov). All questions, answers, and/or addenda, as applicable will be posted on the Town's website at [www.glastonbury-ct.gov](http://www.glastonbury-ct.gov). (Upon entering the website click on Bids & RFP's). The request must be received at least five (5) business days prior to the advertised response deadline. **It is the respondent's responsibility to check the website for addenda prior to submission of any bid/proposal.**

**01.00 WORKMANSHIP, MATERIALS AND EMPLOYEES**

01.01 Wherever in this contract the word "Engineer" is used, it shall be understood as referring to the Town Engineer/Manager of Physical Services of the Town of Glastonbury acting personally or through any assistants duly authorized.

01.02 The entire work described herein shall be completed in accordance with the plans and specifications to the full intent and meaning of the same. Unless otherwise specified, all materials incorporated in the permanent work shall be new, and both workmanship and material shall be of good quality. The Contractor shall, if required, furnish satisfactory evidence as to the kind and quality of materials.

01.03 The wording "furnish", "install", "construct", "furnish and install", or any similar terms, unless specifically noted to the contrary, shall include all labor, materials, water, tools, equipment, light, power, transportation, and any other services required for the completion of the work.

01.04 The Contractor shall at all times enforce strict discipline and good order among his employees, and shall seek to avoid employing on the work any unfit person or anyone not skilled in the work assigned to him.

**02.00 SUPERINTENDENT**

02.01 The Contractor shall keep on the work during its progress, in the absence of the Contractor, a competent Superintendent. The Superintendent shall be acceptable to the Engineer and shall fully represent the Contractor. All directions given to the Superintendent shall be binding as if given to the Contractor.

**03.00 PRECONSTRUCTION MEETING**

03.01 A Preconstruction Meeting will be held with the Engineer, Contractor, and any private utility company prior to commencing any work. The Engineer shall arrange the meeting based on a mutually convenient time.

**04.00 PERMITS**

04.01 Other than local permits, all permits, licenses, and fees required for the performance of the Contract work shall be secured and paid for by the Contractor.

**05.00 PROPERTY ACCESS**

05.01 The Contractor shall take all proper precautions to protect from injury or unnecessary interference, and provide proper means of access to abutting property where the existing access is cut off by the Contractor.

05.02 The Contractor shall take all proper precautions to protect persons from injury or unnecessary inconvenience and leave an unobstructed way along the public and private places for travelers, vehicles, and access to hydrants.

05.03 The Contractor shall make arrangements with the adjacent property owners for such trespass as he may reasonably anticipate in the performance of the work. All such arrangements shall be reported, in writing, to the Engineer.

**06.00 PROTECTION OF THE PUBLIC AND OF WORK AND PROPERTY**

06.01 The Contractor shall continuously maintain adequate protection of all work from damage, and shall take all reasonable precautions to protect the Town from injury or loss arising in connection with the Contract.

06.02 The Contractor shall adequately protect adjacent private and public property as provided by law and the Contract Documents.

06.03 The Contractor shall make good any damage, injury, or loss of his work and to the property of the Town resulting from lack of reasonable protective precautions.

**07.00 EXISTING IMPROVEMENTS**

07.01 The Contractor shall conduct his work so as to minimize damage to existing improvements. Except where specifically stated otherwise in the specifications, drawings, or as directed by the Engineer, it will be the responsibility of the Contractor to restore to their original condition, as near as practical, all improvements on public or private property. This shall include:

- a. Property within and adjacent to the side of installation such as shrubs, walks, driveways, fences, etc.
- b. Utility mains, ducts, poles, and services. The Contractor is hereby notified that utilities, if/where shown on the plans, are at approximate locations. These locations are subject to possible errors in the source of information and errors in transcription. The Contractor shall make certain of the exact location of all mains, ducts, poles, and services prior to excavation.

**08.00 SEPARATE CONTRACTS**

08.01 The Engineer reserves the right to let other contracts in connection with this work. The Contractor shall afford other contractors reasonable opportunity for the introduction and storage of their materials and the execution of their work, and shall properly connect and coordinate his work with theirs. Wherever work being done by the Town of Glastonbury forces or by other contractors is contiguous to work covered by this Contract, the respective rights of the various interests involved shall be established by the Engineer to secure the completion of the various portions of the work.

**09.00 INSPECTION OF WORK**

09.01 The Town shall provide sufficient personnel for the inspection of the work.

09.02 The Engineer shall at all times have access to the work whenever it is in preparation or progress, and the Contractor shall provide proper facilities for such access and for inspection.

09.03 If the specifications or the Engineer's instructions require any work to be specially tested or approved, the Contractor shall give the Engineer timely notice of its readiness for inspection and, if the inspection is by another authority other than the Engineer, of the date fixed for such inspection. Inspections by the Engineer shall be made promptly. If any work should be covered up without approval or consent of the Engineer, it must, if required by the Engineer, be uncovered for examination and properly restored at the Contractor's expense.

09.04 Reinspection of any work may be ordered by the Engineer. If such work is found to be in accordance with the Contract Documents, the Town shall pay the cost of reinspection and replacement. If such work is not in accordance with the Contract Documents, the Contractor shall pay such cost.

**10.00 RIGHT TO INCREASE OR DECREASE WORK**

10.01 The Town shall have the right to increase or decrease the amount of work herein specified as may be required.

**11.00 RIGHT OF ENGINEER TO STOP WORK FOR WEATHER CONDITIONS**

11.01 Should the work, in the opinion of the Engineer, be in danger by reason of inclemency of weather, or could not be finished in time to prevent such danger, the Contractor shall cease operations upon order of the Engineer, and shall not resume them until ordered to do so by the Engineer when the weather conditions are favorable. The Contractor shall, upon such orders, discontinue work, remove all materials or appliances for or in use upon the work, and place the streets in proper condition for use by the public during the time the work is suspended as herein provided, without cost to the Town.

**12.00 CONTRACTOR TO BE RESPONSIBLE FOR IMPERFECT WORK OR MATERIALS**

12.01 Any faithful work or imperfect material that may be discovered before the acceptance and the payment of the work shall be corrected upon the order of the Engineer. The acceptance and payment of the work does not in any manner relieve the Contractor of his obligation to construct work in the proper manner and the use of materials herein specified.

**13.00 TOWN MAY NOTIFY CONTRACTOR IF WORK IS NOT CARRIED ON SATISFACTORILY**

13.01 If, in the opinion of the Engineer, the Contractor is not proceeding with the work at a sufficient rate of progress so as to finish in the time specified, or has abandoned said work, or is not complying with the terms and stipulations or the Contract and specifications, the Engineer may serve notice on the Contractor to adopt such methods as will ensure the completion of the work in the time specified.

13.02 If, within five days after the Engineer has notified the Contractor that his work is not being carried on satisfactorily as before mentioned, the Engineer shall have the right to annul the Contract and manage the work under the direction of the Engineer, or re-let, for the very best interest of the Town as a new contract, the work under said new Contract shall be considered the responsibility of the defaulting Contractor.



13.03 Additional costs incurred over and above the original Contract shall be borne by the Performance Bond.

**14.00 DEDUCTIONS FOR UNCORRECTED WORK**

14.01 If the Engineer deems it inexpedient to correct work that has been damaged or that was not done in accordance with the Contract, an equitable deduction from the Contract price shall be made therefor.

14.02 The Contractor shall promptly remove from the premises all materials condemned by the Engineer as failing to meet Contract requirements, whether incorporated in the work or not, and the Contractor shall promptly replace and re-execute his own work in accordance with the Contract and without expense to the Town, and shall bear the expense of making good all work by other contractors destroyed or damaged by such removal or replacement.

14.03 If the Contractor does not remove such condemned work and materials as promptly as possible after written notice, the Engineer may remove them and store the materials at the expense of the Contractor.

**15.00 CLEANING UP**

15.01 The Contractor must remove all debris of every description as the work progresses and leave the surroundings in a neat and orderly condition to the satisfaction of the Engineer.

15.02 Upon completion, and before acceptance and final payment, the Contractor shall remove from the site all equipment, forms, surplus material, rubbish and miscellaneous debris and leave the site in a neat and presentable condition.

**16.00 ROYALTIES AND PATENTS**

16.01 The Contractor shall pay all royalties and license fees. He shall defend all suits or claims for infringement of any patent rights and shall save the Town of Glastonbury harmless from loss on account thereof, except that the Town of Glastonbury shall be responsible for all such loss when a particular manufacturer, product, or process is specified by the Town of Glastonbury.

**01.00 NOTICE TO CONTRACTOR**

- 01.01 Intent of Contract: The intent of the Contract is to prescribe a complete work or improvement that the Contractor undertakes to do, in full compliance with the specifications, plans, special provisions, proposal, and Contract. The Contractor shall perform all work in close conformity with the lines, grades, typical cross-sections, dimensions, and other data shown on the plans or as modified by written orders, including the furnishing of all materials, implements, machinery, equipment, tools, supplies, transportation, labor, and all other things necessary to the satisfactory prosecution and completion of the project.
- 01.02 The Contractor is hereby alerted to the fact that the State of Connecticut Department of Transportation Standard Specifications for Roads, Bridges and Incidental Construction, Form 816 (Form 816) and supplements thereto are to be considered part of the Contract Documents. The Form 816 shall not be provided by the Town and any cost associated therewith shall be the responsibility of the Contractor. In case of any discrepancy between the Contract Drawings or Specifications and the Form 816, the matter shall immediately be submitted to the Engineer. The Engineer shall have sole authority in resolving any discrepancies.
- 01.03 Much time and effort has gone into this project in an effort to minimize impact on trees and adjacent properties. Extreme care shall be taken by the Contractor to honor commitments made by the Town. Prior to doing any work, the Contractor should meet with the Engineer to become familiar with the conditions encountered and commitments made.
- 01.04 Limitations on work hours are described in Special Conditions Section 17.02. The Contractor shall understand and strictly comply with these limitations.

**02.00 COMMUNICATIONS**

- 02.01 All notices, demands, requests, instructions, approvals, proposals, and claims must be in writing.
- 02.02 Any notice to, or demand upon, the Contractor shall be sufficiently given if delivered at the office of the Contractor stated on the signature page of the Agreement (or at such other office as the Contractor may, from time to time, designate) in a sealed, postage-prepaid envelope or delivered with charges prepaid to any telegraph company for transmission, in each case addressed to such office.
- 02.03 All papers required to be delivered to the Town shall, unless otherwise specified in writing to the Contractor, be delivered to the Town Engineer/Manager of Physical Services, 2155 Main Street, Glastonbury, CT 06033, and any notice to, or demand upon, the Town shall be delivered at the above address in a sealed, postage-prepaid envelope or delivered with charges prepaid to any telegraph company for transmission, in each case addressed to such office or to such other representatives of the Town, or to such other address as the Town may subsequently specify in writing to the Contractor for such purpose.
- 02.04 Any such notice shall be deemed to have been given as of the time of actual delivery or, in case of mailing, when the same should have been received in due course of post or, in the case of telegrams, at the time of actual receipt, as the case may be.

**03.00 PARTIAL USE OF IMPROVEMENTS**

03.01 The Town may, at its election, give notice to the Contractor and place in use those sections of the work that have been completed, inspected and can be accepted as complying with the Contractor Documents and if, in its opinion, each such section is reasonably safe and fit for the use and accommodation for which it was intended, provided:

- a. The use of such sections of the work shall not materially impede the completion of the remainder of the work by the Contractor.
- b. The Contractor shall not be responsible for any damages or maintenance costs due directly to the use of such sections.
- c. The use of such sections shall in no way relieve the Contractor of his liability due to having used defective materials or to poor workmanship.
- d. The period of guarantee shall not begin until the date of the final acceptance of all work required under this Contract.

**04.00 INSURANCE**

04.01 The Contractor shall, at its own expense and cost, obtain and keep in force during the entire duration of the Project or Work the following insurance coverage covering the Contractor and all of its agents, employees and sub-contractors and other providers of services and shall name the **Town and the Board of Education, its employees and agents as an Additional Insured** on a primary and non-contributory basis to the Bidders Commercial General Liability and Automobile Liability policies. **These requirements shall be clearly stated in the remarks section on the Contractors Certificate of Insurance.** Insurance shall be written with Insurance Carriers approved in the State of Connecticut and with a minimum Best's Rating of A-. In addition, all carriers are subject to approval by the Town. Minimum limits and requirements are stated below:

- a. Worker's Compensation Insurance:
  - Statutory Coverage
  - Employer's Liability
  - \$100,000 each accident/\$500,000 disease-policy limit/\$100,000 disease each employee
- b. Commercial General Liability:
  - Including Premises and Operations, Products and Completed Operations, Personal and Advertising Injury, Contractual Liability and Independent Contractors
  - Limits of Liability for Bodily Injury and Property Damage  
Each Occurrence: \$1,000,000  
Aggregate: \$2,000,000  
(The Aggregate Limit shall apply separately to each job.)
  - A Waiver of Subrogation shall be provided.

c. Automobile Insurance:

- Including all owned, hired, borrowed, and non-owned vehicles
- Limit of Liability for Bodily Injury and Property Damage  
Per Accident: \$1,000,000

04.02 The Bidder shall direct its Insurer to provide a Certificate of Insurance to the Town before any work is performed. The Contractor shall be responsible to notify the Town 30 days in advance with written notice of cancellation or non-renewal. The Certificate shall evidence all required coverage on the General Liability and Auto Liability policies including the Additional Insured and Waiver of Subrogation on the General Liability policy. The Bidder shall provide the Town copies of any such insurance policies upon request.

04.03 INDEMNIFICATION: To the fullest extent permitted by law, the Contractor shall indemnify and hold harmless the Town and the Board of Education and its consultants, agents, and employees from and against all claims, damages, losses and expenses, direct, indirect or consequential (including but not limited to fees and charges of engineers, attorneys and other professionals and court and arbitration costs) to the extent arising out of or resulting from the performance of the Contractor's work, provided that such claim, damage, loss or expense is caused in whole or in part by any negligent act or omission by the Contractor, or breach of its obligations herein or by any person or organization directly or indirectly employed or engaged by the Contractor to perform or furnish either of the services, or anyone for whose acts the Contractor may be liable.

**05.00 WORK BY OTHERS**

05.01 Private utilities, contractors, developers or other parties may be expected to be working within the Contract area during this Contract. It shall be the responsibility of the Contractor to coordinate his work with the work being done by others in order that the construction shall proceed in an efficient and logical manner. The Contractor shall have no claim or claims whatever against the Town, the Engineer, or other parties due to delays or other reasons caused by the work by others or his failure to coordinate such work.

**06.00 CONTRACTOR'S WORK AND STORAGE AREA**

06.01 The Contractor shall contact the Town to determine if any specific locations will be designated, or gain its approval prior to using any area for storage of equipment, materials and trailers during the period of this Contract. The Contractor shall confine his work/storage area to the limits as designated or approved and shall be responsible for the security of the work/storage area. Upon completion of the Contract, the Contractor shall remove all equipment and materials, except as otherwise specified, and restore the site to its original condition as approved by the Engineer and at no cost to the Town.

**07.00 DISPOSAL AREA**

07.01 The Tryon Street Bulky Waste Facility will be available to the Contractor, at no charge, for disposal of materials that are accepted at that facility. Waste disposal guidelines for the Bulky Waste facility are published on the Town web site at the address shown below. Each bidder shall have reviewed and understand these guidelines prior to submitting a bid for the project.

<http://www.glastonbury-ct.gov/Modules/ShowDocument.aspx?documentid=699>

Acceptable materials generally include such materials as brush, stumps, demolition materials, and excess excavated earth materials. Unacceptable materials generally include such items as carpet, appliances, upholstered furniture; hazardous wastes such as pesticides, oil based paints and thinners; or other wastes as designated by the State Department of Environmental Protection. Demolition material cannot contain asbestos or other hazardous materials.

The Contractor shall obtain a disposal area for all other unsuitable or surplus materials at no cost to the Town.

**08.00 DUST CONTROL**

08.01 During the progress of the work, the Contractor shall conduct his operations and maintain the area of his activities so as to minimize the creation and dispersion of dust. If the Engineer decides that it is necessary to use water or calcium chloride for more effective dust control, the Contractor shall furnish and spread the material, as directed, without additional compensation.

**09.00 MAINTENANCE / GUARANTEE PERIOD**

09.01 The Contractor shall be held responsible to the Town for maintenance for a minimum of one-year following completion of all work under this Contract with respect to defects, settlements, etc.

**10.00 PROTECTION OF EXISTING UTILITIES**

10.01 Prior to opening an excavation, effort shall be made to determine whether underground installations, (i.e., sewer, water, fuel, electric lines, etc.) will be encountered and, if so, where such underground installations are located. Before starting any excavation, the Contractor shall submit to the Engineer plans or details showing the proposed method the Contractor will use to support and protect all existing utilities during construction. The furnishing of such plans and details shall not serve to relieve the Contractor of any responsibility for the proper conduct of the work.

10.02 When the excavation approaches the estimated location of such an installation, the exact location shall be determined by careful probing or hand digging, and when it is uncovered, proper supports shall be provided for the existing installation. Utility companies shall be contacted and advised of proposed work prior to the start of actual excavation.

10.03 There will be no extra payment for submitting plans or details for supporting and protecting all existing utilities during construction.

**11.00 TIME FOR COMPLETION/NOTICE TO PROCEED**

11.01 Within ten (10) calendar days after the date of the Notice of Award, the Contractor must provide the appropriate bond and insurance certificates to the Town Purchasing Agent and must be issued a Notice to Proceed and Purchase Order for the Project prior to initiating any work.

11.02 The Contractor is hereby notified that it is the Town's intent to issue a Notice to Proceed immediately following the award of this contract to allow for contract work to be completed in the 2014 calendar year.

11.03 Work shall continue in an orderly fashion such that all contract work is completed within one-hundred ninety five (195) calendar days from the date indicated in the Notice to Proceed.

11.04 When the Contract time is stated on a calendar-day basis, that time shall be the number of consecutive calendar days contained in the Contract period, excluding the time period from each December 1 through the following March 31 (the "winter shutdown period"). The time will be computed as herein provided on a consecutive-day basis, including all Saturdays, Sundays, holidays, and non-work days from April 1 through November 30 of each included year. Time will not be charged for days in the winter shutdown period. If the Engineer so approves, the Contractor may work on certain tasks of the Project during the winter shutdown period with no charge being made against the Contract time.

**12.00 LIQUIDATED DAMAGES**

12.01 As actual damages for any delay in completion of the work that the Contractor is required to perform under this Contract are impossible to determine, the Contractor and the Sureties shall be liable for and shall pay to the Town the sum of \$500.00 as fixed, agreed and liquidated damages for each calendar day of delay from the above-stipulated completion, or completion as modified in writing by both parties, until such work is satisfactorily completed and accepted.

**13.00 SCHEDULE OF DRAWINGS**

13.01 The Contractor is hereby alerted that the plan set entitled "Hebron Avenue and New London Turnpike Intersection Improvements", including twenty-two (22) plan sheets prepared by the Town of Glastonbury Engineering Division and Fuss & O'Neill Inc. is to be considered part of these specifications.

**14.00 CHANGES IN THE WORK**

14.01 The Town reserves the right to perform portions of the work in connection with these plans and specifications. The reduction in the work to be performed by the Contractor shall be made without invalidating the Contract. Whenever work is done by the Town contiguous to other work covered by this Contract, the Contractor shall provide reasonable opportunity for the execution of the work and shall properly coordinate his work with that of the Town.

**15.00 LAYOUT OF WORK**

15.01 The Town shall provide stake-out of the work in accordance with the plans or as directed by the Engineer. The Contractor shall protect all stakes from damage or destruction and shall be responsible to assure that the grade stakes have not been altered prior to actual construction. The Town shall replace grade stakes that have been removed, at no cost to the Contractor, if their removal was caused by reasons beyond reasonable care and protection by the Contractor. If it is determined by the Engineer that the Contractor did not provide reasonable protection, the cost of restaking will be deducted from any amounts due the Contractor in the performance of the work.

**16.00 REMOVAL AND STORAGE OF MATERIALS AND STRUCTURES FOUND ON THE WORK**

16.01 All salvable materials, including traffic signal equipment, topsoil, gravel, fill materials, etc. and structures, including drainage pipes, catch basins and manhole frames and covers, guide railing, etc. that are not to remain in place or that are not designated for use in the work, shall be carefully removed by the Contractor and delivered to the Town Highway Garage located at 2380 New London Turnpike. All salvable materials removed and stored shall remain the property of the Town. The Engineer shall determine the materials or structures to be salvaged.

**17.00 PROSECUTION AND PROGRESS**

17.01 **ADVANCE NOTICE:** The Contractor shall give the Engineer a seven-day advance written notice of construction activities that will alter traffic patterns that result in lane shifts, detours, temporary closures of lane(s), permanent closure of lane(s), or lane reductions. This advance notification will allow the Town to publish news releases and/or provide public radio announcements to inform the public of revised traffic patterns or possible traffic delays. Failure of the Contractor to provide such timely notice shall be considered a breach of Contract and will subject the Contractor to stop work orders until such time as the seven-day notice has been satisfied.

17.02 **ALLOWABLE HOURS OF OPERATION (WORK PERIOD):**

All contract work shall be performed Monday through Friday during daylight hours.

Work on weekends or during other time periods will not be permitted. No work will be allowed on designated Town Holidays unless permission is granted by the Town.

All contract work along the frontage of #195 Hebron Avenue (The Diamond Bar and Grill) shall be performed prior to June 1, 2014 or after September 1, 2014. During the months of May and September, the allowable hours of work in front of this property are 6:00 AM to 11:00 AM. During other months work can proceed unrestricted along this property frontage.

17.03 **CONSTRUCTION PHASING:** Roadway construction may proceed in a single phase, subject to the limitations described in Section 17.04.

- 17.04 SEQUENCE OF CONSTRUCTION OPERATIONS: Work shall be sequenced as follows:
- Bituminous concrete driveway aprons removed during any given work period shall be replaced within that same work period. Curb replacement and topsoiling work behind the curb may take place during a separate work period as required.
- Permanent epoxy resin pavement markings shall be installed 14 days after the placement of the final surface course of pavement to avoid bleeding of asphalt through the epoxy paint. Temporary pavement marking tape shall be installed where necessary on the surface course of pavement as indicated in the Maintenance and Protection of Traffic Special Provision.
- 17.05 OTHER LIMITATIONS: The field installation of a signing pattern shall constitute interference with existing traffic operations and shall not be allowed except during the allowable periods.
- The Contractor shall temporarily provide a 4H:1V traversable slope of suitable material in those areas where a longitudinal dropdown exists. The cost of furnishing, installing and removing this material shall be included in the contract lump sum for "Maintenance and Protection of Traffic."
- The Contractor shall ensure that suitable temporary access is provided to all residential and commercial driveways at all times as described in the Special Provision for Maintenance and Protection of Traffic.
- 18.00 EXTRA WORK AND RETAINAGE**
- 18.01 Extra and cost plus work shall be governed by Article 1.04.05 and Article 1.09.04 of the Form 816.
- 18.02 Retainage shall be governed by Article 1.09.06 of the Form 816, except that the retainage amount shall be equal to five (5) percent.
- 19.00 SUBMITTALS AND MATERIALS TESTING**
- 19.01 The Contractor shall provide source and supply information, sieve analysis, and material samples for gravel subbase, process stone base, modified riprap, and other granular materials to the Town for review and approval. The Town shall retain a lab for testing of these materials as required and shall perform in place compaction testing at no expense to the Contractor.
- 19.02 Shop drawings / catalog cuts shall be provided by the Contractor for all pre-cast concrete structures, pipes and fittings, erosion control products, seed mixes, and other items to be supplied for review and approval by the Engineer as described in the specifications and the Form 816.
- 19.03 Mix designs for all bituminous and portland cement concrete materials shall be provided by the Contractor to the Engineer for review and approval.
- 19.04 Certified Materials Test Reports and Materials Certificates shall be provided for all products and materials to be provided under this contract as described in these specifications and the Form 816.



Proposal of \_\_\_\_\_  
(hereinafter called "Bidder"), organized and existing under the laws of the State of \_\_\_\_\_  
\_\_\_\_\_, doing business as \_\_\_\_\_  
\_\_\_\_\_.

To the Town of Glastonbury (hereinafter called "Town").

In compliance with your Invitation to Bid, the Bidder hereby proposed to furnish materials and/or services as per Bid Number GL-2014-28 in strict accordance with the Bid Documents, within the time set forth therein, and at the prices stated below.

By submission of this bid, the Bidder certifies, and in the case of a joint bid each party thereto certifies as to their own organization that this bid has been arrived at independently without consultation, communication, or agreement as to any matter relating to this bid with any other Bidder or with any competitor.

The Bidder acknowledges receipt of the following:

Addendum #1 \_\_\_\_\_

Addendum #2 \_\_\_\_\_

Addendum #3 \_\_\_\_\_

It is the responsibility of the Bidder to check the Town's website for any Addendum before submitting the bid.

TOWN OF GLASTONBURY

BID / PROPOSAL

GL # or RPGL #

2014-28

DATE ADVERTISED

3/19/2014

DATE / TIME DUE

4/8/2014 at  
11:00 A.M.

NAME OF PROJECT

Hebron Avenue and New London Turnpike  
Intersection Improvements

It is the responsibility of the Bidder to clearly mark the outside of the bid envelope with the Bid Number, Date and Time of Bid Opening, and it also THE RESPONSIBILITY OF THE BIDDER TO CHECK THE TOWN'S WEBSITE BEFORE SUBMITTING BID FOR ADDENDUMS POSTED PRIOR TO BID OPENING.

**OTHER ITEMS REQUIRED WITH SUBMISSION OF BID PROPOSAL:**

The following bid checklist describes items required for inclusion with the above-referenced bid proposal package. It is provided for the convenience of the bidders and, therefore, should not be assumed to be a complete list.

- \_\_\_\_\_ 1. Included Bid Bond as per Section 10 of the Information for Bidders.
- \_\_\_\_\_ 2. Included Disclosure of Past and Pending Mediation, Arbitration, and Litigation cases against the Bidder or its Principals as per Section 17 of the Information for Bidders.
- \_\_\_\_\_ 3. Included Qualifications Statement as per Section 21 of the Information for Bidders.
- \_\_\_\_\_ 4. Checked Town web site for Addendums and acknowledged Addendums on page BP-1.
- \_\_\_\_\_ 5. Acknowledged Code of Ethics on page BP-8.
- \_\_\_\_\_ 6. Clearly marked envelope with Bid Number, Date, and Time of opening.

**HEBRON AVENUE AND NEW LONDON TURNPIKE INTERSECTION  
 BID PROPOSAL**

**BID #GL-2014-28**

BIDDER NAME: \_\_\_\_\_

<u>LINE NO.</u>	<u>ITEM NO.</u>	<u>ITEM DESCRIPTION</u>	<u>UNIT</u>	<u>QTY</u>	<u>UNIT PRICE</u>	<u>EXT</u>
-----------------	-----------------	-------------------------	-------------	------------	-------------------	------------

1	0000151A	Clearing and Grubbing	LS	1		
2	0202000A	Earth Excavation	CY	300		
3	0202451A	Test Pit Excavation	CY	5		
4	0202513A	Removal of Concrete Sidewalk	SY	425		
5	0202529	Cut Bituminous Concrete Pavement	LF	1,250		
6	0202553A	Set Monument in Sidewalk	EA	8		
7	0209001	Formation of Subgrade	SY	540		
8	0212000A	Subbase	CY	150		
9	0219001A	Sediment Control Sack	EA	10		
10	0406010-1	Bituminous Concrete Class I	TN	100		
11	0406010-4	Bituminous Concrete Class IV	TN	165		
12	0406236	Material for Tackcoat	Gal	60		
13	0507001A	Type "C" Catch Basin	EA	4		
14	0507003A	Remove Existing Catch Basin	EA	4		
15	0507006A	Replace Catch Basin Top	EA	2		
16	0507781A	Reset Manhole Top	EA	6		
17	0507821A	Convert Catchbasin to Type C-L Catch Basin	EA	1		
18	0507831A	Convert Catchbasin to Manhole	EA	1		
19	0651012A	15" R.C. Pipe	LF	63		

**HEBRON AVENUE AND NEW LONDON TURNPIKE INTERSECTION  
 BID PROPOSAL**

**BID #GL-2014-28**

BIDDER NAME: \_\_\_\_\_

<u>LINE NO.</u>	<u>ITEM NO.</u>	<u>ITEM DESCRIPTION</u>	<u>UNIT</u>	<u>QTY</u>	<u>UNIT PRICE</u>	<u>EXT</u>
20	0815001	Bit Conc Lip Curb	LF	800		
21	0921001A	Concrete Sidewalk	SF	3,520		
22	0921002A	Concrete Sidewalk - 8" Thick	SF	300		
23	0921005A	Concrete Sidewalk Ramp	EA	10		
24	0922001A	Bituminous Concrete Sidewalk	SY	40		
25	0922501A	Bituminous Concrete Driveway	SY	400		
26	0944000A	Grading and Topsoiling	SY	1,200		
27	0950005A	Turf Establishment	SY	1,200		
28	0970006A	Trafficperson (Municipal Police Officer)	EST	1	\$ 20,000.00	\$ 20,000.00
29	0970007A	Trafficperson (Uniformed Flagger)	HR	400		
30	0971001A	Maintenance and Protection of Traffic	LS	1		
31	0979001	Traffic Cones	EA	40		
32	0979002	Traff Drums	EA	20		
33	0979003A	Construction Barricade Type III	EA	10		
34	1001001	Trenching And Backfilling	LF	925		
35	1002015	Rock In Foundation Excavation	VF	5		
36	1002202	Traffic Control Foundation- Mast Arm	EA	4		
37	1002203	Traffic Control Foundation-Pedestal- Type I	EA	4		
38	1002208	Traffic Control Foundation - Controller - Type IV	EA	1		

**HEBRON AVENUE AND NEW LONDON TURNPIKE INTERSECTION  
 BID PROPOSAL**

**BID #GL-2014-28**

BIDDER NAME: \_\_\_\_\_

<u>LINE NO.</u>	<u>ITEM NO.</u>	<u>ITEM DESCRIPTION</u>	<u>UNIT</u>	<u>QTY</u>	<u>UNIT PRICE</u>	<u>EXT</u>
39	1008115	2" Rigid Metal Conduit In Trench	LF	425		
40	1008117	3" Rigid Metal Conduit In Trench	LF	25		
41	1008215	2" Rigid Metal Conduit Under Roadway	LF	415		
42	1008217	3" Rigid Metal Conduit Under Roadway	LF	65		
43	1010001	Concrete Handhole	EA	5		
44	1010052A	Cast Iron Handhole Cover	EA	5		
45	1017032A	Service (Metered)	EA	1		
46	1102002A	8' Aluminum Pedestal	EA	4		
47	1104028A	30' Steel Mast Arm Assembly	EA	1		
48	1104031A	35' Steel Mast Arm Assembly	EA	2		
49	1104037A	45' Steel Mast Arm Assembly	EA	1		
50	1105101A	1 Way, 1 Section Mast Arm Traffic Signal	EA	10		
51	1105103A	1 Way, 3 Section Mast Arm Traffic Signal	EA	8		
52	1106001A	1 Way Pedestrian Signal Pole Mounted	EA	4		
53	1106003A	1 Way Pedestrian Signal Pedestal Mounted	EA	4		
54	1107011A	Accessible Pedestrian Signal Detector Type A	EA	8		
55	1108115A	Full Actuated Controller 8 Phase	EA	1		
56	1108722A	Vehicle Emitter	EA	1		
57	1108724A	Phase Selector	EA	1		

**HEBRON AVENUE AND NEW LONDON TURNPIKE INTERSECTION  
 BID PROPOSAL**

**BID #GL-2014-28**

BIDDER NAME: \_\_\_\_\_

<u>LINE NO.</u>	<u>ITEM NO.</u>	<u>ITEM DESCRIPTION</u>	<u>UNIT</u>	<u>QTY</u>	<u>UNIT PRICE</u>	<u>EXT</u>
58	1111407A	Camera Video Detection System	EA	1		
59	1112410A	Detector (Type A)	EA	4		
60	1112470A	Pre-Emption System Chassis	EA	1		
61	1113014	3 Conductor No. 8 AWG Type SE Style THW	LF	215		
62	1113101	3 Conductor No. 14 Cable	LF	945		
63	1113102	5 Conductor No. 14 Cable	LF	695		
64	1113103	7 Conductor No. 14 Cable	LF	945		
65	1113104	9 Conductor No. 14 Cable	LF	655		
66	1113550A	Detector Cable (Optical)	LF	695		
67	1113812A	Uninterruptible Power Supply (UPS)	EA	1		
68	1113901	Camera Cable	LF	660		
69	1118012A	Removal And/Or Relocation of Traffic Signal Equip.	LS	1		
70	1118051A	Temporary Signalization (Site No. 1)	LS	1		
71	1206023A	Removal and Relocation of Existing Signs	LS	1		
72	1208928A	Sign Face Sheet Aluminum (Type III Refl. Sheeting)	SF	98		
73	1210101A	4" White Epoxy Resin Pavement Markings	LF	1,850		
74	1210102A	4" Yellow Epoxy Resin Pavement Marking	LF	1,800		
75	1210105A	Epoxy Resin Pavement Marking Sym. & Leg.	SF	1,600		
76	1211001	Removal of Pavement Markings	SF	2,800		

**HEBRON AVENUE AND NEW LONDON TURNPIKE INTERSECTION  
 BID PROPOSAL**

**BID #GL-2014-28**

BIDDER NAME: \_\_\_\_\_

<u>LINE NO.</u>	<u>ITEM NO.</u>	<u>ITEM DESCRIPTION</u>	<u>UNIT</u>	<u>QTY</u>	<u>UNIT PRICE</u>	<u>EXT</u>
77	1220013A	Construction Signs Bright Flourescent Sheeting	SF	200		
78	1302060A	Adjust Gate Box (Gas)	EA	5		
79	1302061A	Adjust Gate Box (Water)	EA	7		
80	0975002	Mobilization	LS	1		

TOTAL BID BASE BID AMOUNT: \$ \_\_\_\_\_

WRITTEN TOTAL BASE BID AMOUNT: \_\_\_\_\_

ADD ALTERNATE ITEMS:

<u>LINE NO.</u>	<u>ITEM NO.</u>	<u>ITEM DESCRIPTION</u>	<u>UNIT</u>	<u>QTY</u>	<u>UNIT PRICE</u>	<u>EXT</u>
81	0813012	5" x 17" Granite Stone Curb (ALT 1)	LF	30		
82	0813013	5" x 17" Curved Granite Stone Curb (ALT 2)	LF	250		

TOTAL BID AMOUNT INCLUDING ADD ALTERNATE ITEMS: \$ \_\_\_\_\_

WRITTEN TOTAL BID AMOUNT INCLUDING ADD ALTERNATE ITEMS: \_\_\_\_\_

**CODE OF ETHICS:**

I/We have reviewed a copy of the Town of Glastonbury's Code of Ethics and agree to submit a Consultant Acknowledgement Form if I/We are selected. Yes \_\_\_\_\_ No \_\_\_\_\_\*

\*Bidder is advised that effective August 1, 2003, the Town of Glastonbury cannot consider any bid or proposal where the Bidder has not agreed to the above statement.

Respectfully submitted:

\_\_\_\_\_  
Type or Print Name of Individual

\_\_\_\_\_  
Doing Business as (Trade Name)

\_\_\_\_\_  
Signature of Individual

\_\_\_\_\_  
Street Address

\_\_\_\_\_  
Title

\_\_\_\_\_  
City, State, Zip Code

\_\_\_\_\_  
Date

\_\_\_\_\_  
Telephone Number/Fax Number

\_\_\_\_\_  
E-Mail Address

\_\_\_\_\_  
SS# or TIN#

(Seal – If bid is by a Corporation)

Attest



**SPECIAL PROVISIONS**

**INDEX OF SPECIAL PROVISIONS**

NOTICE TO CONTRACTOR - TRAFFIC SIGNALS ..... 3  
SECTION 1.05 - CONTROL OF THE WORK..... 5  
SECTION 1.06 CONTROL OF MATERIALS..... 6  
SECTION 1.07 - LEGAL RELATIONS AND RESPONSIBILITIES ..... 8  
SECTION 1.08 - PROSECUTION AND PROGRESS..... 9  
ITEM # 0000151A CLEARING AND GRUBBING ..... 10  
ITEM # 0202000A EARTH EXCAVATION ..... 12  
ITEM # 0202513A REMOVAL OF CONCRETE SIDEWALK ..... 12  
ITEM # 0202100A ROCK EXCAVATION AND DISPOSAL..... 13  
ITEM # 0202451A TEST PIT EXCAVATION..... 17  
ITEM # 0202553A SET MONUMENT IN CONCRETE SIDEWALK..... 18  
ITEM # 0204503A TRENCH DEWATERING ..... 19  
ITEM # 0205001A EARTH TRENCH EXCAVATION..... 20  
ITEM # 0212000A SUBBASE ..... 28  
ITEM # 0212300A PROCESSED STONE BASE ..... 29  
ITEM # 0219001A SEDIMENT CONTROL SACK ..... 30  
ITEM # 406010-1 BITUMINOUS CONCRETE CLASS 1 ..... 31  
ITEM # 406010-4 BITUMINOUS CONCRETE CLASS 4 ..... 31  
ITEM # 0507001A TYPE "C" CATCH BASIN ..... 47  
ITEM # 0507003A REMOVE EXISTING CATCH BASIN ..... 47  
ITEM # 0507821A CONVERT CATCH BASIN TO TYPE "C-L" CATCH BASIN ..... 47  
ITEM # 0507831A CONVERT CATCH BASIN TO MANHOLE ..... 47  
ITEM # 0507006A REPLACE CATCH BASIN TOP ..... 48  
ITEM # 0507781A RESET MANHOLE TOP ..... 49  
ITEM # 0651012A 15" R.C. PIPE ..... 50  
ITEM # 0921001A CONCRETE SIDEWALKS ..... 51  
ITEM # 0921002A CONCRETE SIDEWALKS – 8" THICK..... 51  
ITEM # 0921005A CONCRETE SIDEWALK RAMPS..... 51  
ITEM # 0922001A BITUMINOUS CONCRETE SIDEWALK ..... 54  
ITEM # 0922501A BITUMINOUS CONCRETE DRIVEWAY ..... 54  
ITEM # 0944000A GRADING AND TOPSOILING ..... 56  
ITEM # 0950005A TURF ESTABLISHMENT ..... 57  
ITEM # 0970006A TRAFFICPERSON (MUNICIPAL POLICE OFFICER)..... 60  
ITEM # 0970007A TRAFFICPERSON (UNIFORMED FLAGGER)..... 60  
ITEM # 0971001A MAINTENANCE AND PROTECTION OF TRAFFIC..... 61  
ITEM # 0979003A CONSTRUCTION BARRICADE TYPE III ..... 79  
ITEM # 1010052A CAST IRON HANDHOLE COVER..... 80  
ITEM # 1017032A SERVICE (METERED)..... 81  
ITEM # 1102002A 8' ALUMINUM PEDESTAL..... 83  
ITEM # 1104028A 30' STEEL MAST ARM ASSEMBLY ..... 84  
ITEM # 1104031A 35' STEEL MAST ARM ASSEMBLY ..... 84  
ITEM # 1104037A 45' STEEL MAST ARM ASSEMBLY ..... 84  
ITEM # 1105101A 1 WAY, 1 SECTION MAST ARM TRAFFIC SIGNAL..... 95  
ITEM # 1105103A 1 WAY, 3 SECTION MAST ARM TRAFFIC SIGNAL..... 95  
ITEM # 1106001A 1 WAY PEDESTRIAN SIGNAL POLE MOUNTED ..... 98  
ITEM # 1106003A 1 WAY PEDESTRIAN SIGNAL PEDESTAL MOUNTED..... 98  
ITEM # 1107011A ACCESSIBLE PEDESTRIAN SIGNAL & DETECTOR (TYPE A) ..... 99  
ITEM # 1108115A FULL ACTUATED CONTROLLER 8 PHASE..... 102  
ITEM # 1108722A VEHICLE EMITTER..... 122  
ITEM # 1108724A PHASE SELECTOR ..... 122

HEBRON AVENUE AND NEW LONDON TURNPIKE INTERSECTION  
SPECIAL PROVISIONS

BID #GL-2014-28

ITEM # 1112410A	DETECTOR (TYPE A).....	122
ITEM # 1112470A	PRE-EMPTION SYSTEM CHASSIS .....	122
ITEM # 1113550A	DETECTOR CABLE (OPTICAL).....	122
ITEM # 1111407A	CAMERA VIDEO DETECTION SYSTEM.....	127
ITEM # 1113812A	UNINTERRUPTIBLE POWER SUPPLY (UPS) .....	134
ITEM # 1118012A	REMOVAL AND/OR RELOCATION OF TRAFFIC SIGNAL EQUIPMENT .....	138
ITEM # 1118051A	TEMPORARY SIGNALIZATION (SITE NO. 1).....	141
ITEM # 1206023A	REMOVAL AND RELOCATION OF EXISTING SIGNS.....	144
ITEM # 1208928A	SIGN FACE SHEET ALUMINUM (TYPE III REFLECTIVE SHEETING) .....	145
ITEM # 1210101A	4" WHITE EPOXY RESIN PAVEMENT MARKINGS .....	147
ITEM # 1210102A	4" YELLOW EPOXY RESIN PAVEMENT MARKINGS .....	147
ITEM # 1210105A	EPOXY RESIN PAVEMENT MARKINGS, SYMBOLS AND LEGENDS.....	147
ITEM # 1220013A	CONSTRUCTION SIGNS – BRIGHT FLUORESCENT SHEETING .....	148
ITEM # 1302060A	ADJUST GATE BOX (GAS).....	151
ITEM # 1302061A	ADJUST GATE BOX (WATER).....	152

**NOTICE TO CONTRACTOR - TRAFFIC SIGNALS**

The Contractor is hereby notified that certain conditions pertaining to the installation of new signals and maintenance of traffic signal operations are required when relevant, as part of this contract.

Qualified/Unqualified Workers

U.S. Department of Labor  
Occupational Safety & Health Administration (OSHA) [www.osha.gov](http://www.osha.gov)  
Part Number 1910  
Part Title Occupational Safety & Health Administration  
Subpart S  
Subpart Title Electrical  
Standard Number 1910.333  
Title Selection and use of work practices

Completion of this project will require Contractor employees to be near overhead utility lines. All workers and their activities when near utility lines shall comply with the above OSHA regulations. In general, unqualified workers are not allowed within 10 feet of overhead, energized lines. It is the contractor's responsibility to ensure that workers in this area are qualified in accordance with OSHA regulations.

The electric distribution company is responsible to provide and install all necessary anchors and guy strands on utility poles. It is the Contractor's responsibility to coordinate with the utility company to ensure proper placement of the anchor. The Contractor will also reimburse the utility company the full cost for the installation of the anchor and guy.

This project includes countdown pedestrian signals. The countdown display is allowed only during the flashing don't walk time of the pedestrian movement.

The Controller Unit (CU) shall conform to the 2012-2015 Functional Specifications for Traffic Control Equipment. The Functional Specifications require the CU meet NEMA Standard Publication No. TS2-1992 Type 2. The Functional Specifications are available on the Departments' web site, [www.ct.gov/dot/](http://www.ct.gov/dot/).

Under Maintenance and Protection of Traffic (M&PT) and Temporary Signalization the Contractor is required to keep in operation the following: all vehicle and pedestrian signals including necessary support structures; all vehicle and pedestrian detection; the pre-emption system; and coordination to the master, if in a system.

Existing or new span poles or utility poles cannot be double loaded without proper guying.

The contractor will be held liable for all damage to existing equipment resulting from his or his subcontractor's actions.

A credit will be deducted from monies due the Contractor for all maintenance calls responded to by Town of Glastonbury personnel.

All existing traffic appurtenances, in particular steel span poles, controller cabinets and pedestals shall be removed from the proposed roadway prior to excavation. The Contractor shall work with the utility companies to either relocate or install all traffic signal appurtenances prior to the roadway reconstruction.

The Contractor must install permanent or temporary spans in conjunction with utility company relocations. He then must either install the new signal equipment and controller or relocate the existing equipment.

The following notes apply to projects which include Optical or Siren Pre-emption:

- Pre-emption is to operate through the internal pre-emption of the signal controller.
- If not present in a controller cabinet the contractor shall install the following items:
  - Pre-emption disconnect switch.
  - Pre-emption termination panel with "D" harness.
  - Pre-emption test pushbuttons.
- Contractor must provide a chart, or print out of the program steps and settings.
- Detector locations are for illustration only. Exact locations shall be determined by the Manufacturer or his designated representative. Detector cables are to be installed continuous between each detector and the auxiliary equipment cabinet.

Mast arm assemblies and foundations have new specifications and are to be designed based on The AASHTO 2009 Standards. Refer to new Specifications and Typical Detail Sheets.

All Mast Arm mounted signs are to be fixed mounted. Method of mounting must be submitted to the Division of Traffic for approval prior to installation unless otherwise noted.

Prior to the start of fabrication of steel mast arm assemblies, the contractor shall, in the field, verify the location of the foundations, and establish and verify all elevations, dimensions, and longitudinal grades. The contractor shall submit a cross section for each mast arm assembly in accordance with the special provisions of Article 1.05.02, prior to the submission of the shop drawings.

The contractor is advised that signal appurtenances (mast arms, span poles, pedestals and controllers) when in or adjacent to sidewalks, shall be field located to provide a free path of not less than 3 ft. (0.9 meters).

**SECTION 1.05 - CONTROL OF THE WORK**

**Article 1.05.02 - Plans, Working Drawings and Shop Drawings is supplemented as follows:**

**Subarticle 1.05.02 - (2) is supplemented by the following:**

When required by the contract documents or when ordered by the Town of Glastonbury or the Engineer, The Contractor shall prepare and submit five (5) sets of catalog cuts and/or shop drawings for all traffic signal items to Fuss & O'Neill, Inc. for approval before fabrication.

Mark G. Vertucci, PE, PTOE  
Senior Project Manager  
Fuss & O'Neill  
146 Hartford Road  
Manchester, CT 06040

and one (1) set to the Town of Glastonbury Engineering Division.

Please forward to:

Stephen Braun  
Assistant Town Engineer  
2155 Main Street, P.O. Box 6523  
Glastonbury, CT 06033-6523

Following approval of the shop drawings, the Engineer will provide one hard copy or PDF document of the approved submittal to the Connecticut Department of Transportation Consultant Design Unit, one to the Town of Glastonbury, and two hard copies or one PDF document to the contractor. Engineer will retain one hard copy of the approved shop drawings.

**SECTION 1.06 CONTROL OF MATERIALS**

**Article 1.06.01 - Source of Supply and Quality:**

Add the following:

For the following traffic signal items the contractor shall submit a complete description of the item, working drawings, catalog cuts and other descriptive literature which completely illustrates such items presented for formal approval. Such approval shall not change the requirements for a certified test report and materials certificate as may be called for. All shop drawings shall be submitted at one time, unless otherwise approved by the engineer.

Steel Mast Arm Assembly	Phase Selector
Traffic Signals	Pre-Emption System Chassis
LED Traffic Signal Lamp Unit	Detector Cable (Optical)
Pedestrian Signals	Confirmation Light
Pedestrian Pushbuttons and Signs	Video Detection
Pre-Emption Button	Camera Assembly
Accessible Pedestrian Signal	Camera Extension Bracket
Controller	Video Detector Processor
Solid State Time Switch	Camera Cable
Solid State Load Switch	Concrete Handholes and Covers
Conflict Monitor	Mast Arm and Pedestal Foundations
Solid State Flasher	Uninterruptible Power Source (UPS)
Pre-Emption Equipment	
Vehicle Emitter	

**Article 1.06.07 - Certified Test Reports and Materials Certificate.**

Add the following:

1) For the materials in the following items, a Certified Test Report will be required confirming their conformance to the requirements set forth in these plans or specifications or both. Should the consignee noted on a Certified Test Report be other than the Prime Contractor, then Materials Certificates shall be required to identify the shipment.

Steel Mast Arm Anchor Bolts  
Steel Mast Arm Assembly

2) For the materials in the following items, a Materials Certificate will be required confirming their conformance to the requirements set forth in these plans or specifications or both.

- Steel Mast Arm Assembly
- Traffic Signals
- Flasher Cabinet
- LED Traffic Signal Lamp Unit
- Pedestrian Signals
- Pedestrian Pushbuttons and Signs
- Pre-Emption Button
- Audible Pedestrian Signal
- Controller
  - Solid State Time Switch
  - Solid State Load Switch
  - Conflict Monitor
  - Solid State Flasher
- Pre-Emption Equipment
  - Vehicle Emitter
  - Phase Selector
  - Pre-Emption System Chassis
  - Detector Cable (Optical)
  - Confirmation Light
- Video Detection
  - Camera Assembly
  - Camera Extension Bracket
  - Video Detector Processor
  - Camera Cable
- Concrete Handholes and Covers
- Mast Arm and Pedestal Foundations
- Uninterruptible Power Source (UPS)



**SECTION 1.07 - LEGAL RELATIONS AND RESPONSIBILITIES**

**Article 1.07.13** - Contractor's Responsibility for Adjacent Property, Facilities and Services is supplemented as follows:

The following company and representative shall be contacted by the Contractor to coordinate the protection of their utilities on this project 30 days prior to the start of any work on this project involving their utilities:

Town of Glastonbury  
Daniel A. Pennington, PE  
Manager of Physical Services/Town Engineer  
2155 Main Street  
Glastonbury, CT 06033-6523

Fiber Technologies Networks, LLC  
Mr. Mark Schnauber,  
Controller  
300 Meridian Center  
Rochester, New York 14624  
(585) 697-5107

Connecticut Natural Gas Corporation, Engineering  
Department  
Mr. Vasant C. Patel,  
Manager - Utility Coordination  
76 Meadow Street, 1st Floor  
East Hartford, CT 06108  
(860) 727-3114  
vpatel@ctgcorp.com

Spectra Energy Operating Company, LLC (formerly:  
Algonquin Gas  
Transmission Company)  
Mr. Bradley E. Franzese,  
Area Manager  
252 Shunpike Road  
Cromwell, CT 06416  
(860) 635-0800 EXT: FAX: (860) 635-2632  
befranzese@spectraenergy.com

AT&T Connecticut (The Southern New England  
Telephone Company)  
Mr. Eric Clark,  
Manager OSP Engineering  
1441 North Colony Road  
Meriden, CT 06450-4101  
(203) 238-7407 EXT: FAX: (203) 237 8902  
[ec9795@att.com](mailto:ec9795@att.com)

CoxCom, Inc.  
Mr. Thomas Derway,  
Capital/Utility Coordinator  
801 Parker Street  
Manchester, CT 06045  
(860) 432-5040 FAX: (860) 512-5115  
thomas.derway@cox.com

Northeast Utilities Service Company  
Mr. Wayne D. Gagnon,  
Engineering Manager System Projects  
107 Selden Street  
Berlin, CT 06037  
(860) 665-2473, FAX (860) 665-2002  
[gagnowd@nu.com](mailto:gagnowd@nu.com)

## **SECTION 1.08 - PROSECUTION AND PROGRESS**

### **Article 1.08.03 - Prosecution of Work:**

Add the following:

The project will be constructed in various phases as described herein.

#### **Phase 1 – Organization Phase up to (150) Calendar Days.**

The first phase is to afford the Contractor time for the administrative/engineering/procurement function required for the project. This would include such items as performing construction staking, digging test pits, submitting catalog cuts or shop drawings and purchasing materials. Actual construction is not permitted during the period. The Contractor is to use this time to fully prepare for the successive phases so that construction can proceed quickly and efficiently. During the phase, after the construction staking is complete and underground utilities are marked out the Contractor, the designer, the Town of Glastonbury and the Engineer will walk the project to determine if there are test pits necessary or if there are any apparent conflicts with private property, utilities, or other roadside appurtenances such as obstructions, rocks, large trees, etc. Those conflicts will be resolved prior to ordering equipment for the specific area where the conflict exists.

#### **Phase 2 – Construction Phase – (45) Calendar Days**

When all apparent conflicts have been identified and resolved, and written commitments have been received from suppliers that all equipment and materials will be received within 30 days, the Contractor may request that the construction phase begin. Once commencement of construction begins, as and when approved by the Engineer, the Contractor will have (45) consecutive calendar days to complete the work, including cleanup. That work, once started, must be completed within the time established for the original construction phase, and liquidated damages, as specified elsewhere in the Contract, will be assessed against the Contractor per calendar day from that day until the date on which the work is complete. If unforeseen situations arise, the Contractor may request an extension of time for an individual location and, if justified, the Engineer may grant an extension of time for that location. Granting an extension of time for one location will not entitle the Contractor to extensions of time for other locations in the project.

Phase 2 will not start prior to the conclusion of Phase 1. If Phase 1 is completed during the winter period Phase 2 will begin on the following April 1. The Contractor may begin Phase 2 only with prior written permission from the Engineer to do so, unless all the work allotted for this phase can be completed prior to the winter period. If the project will not be completed in the one construction season, the contractor shall complete all work started at or between intersections, including cleanup, prior to the winter shutdown.

#### **New Work**

Additional work, including work at a separate location, may be added to the contract in accordance with Article 1.04.05 of the Standard Specifications. This work may result in a contract extension, which would require an organization phase and a construction phase for the new location. If a contract extension is granted for the additional work, liquidated damages for this portion of the work will be negotiated with the Contractor. Such an extension of time would not affect the time allowed for the original work in the contract. Original work, once started must be completed within the original construction phase, and liquidated damages will be assessed for any days beyond that phase which the Contractor takes to complete the original work.

**ITEM # 0000151A**                      **CLEARING AND GRUBBING**

General: The Contractor shall furnish all labor, materials, tools, and equipment necessary and shall do all work to prepare the site as indicated on the drawings and as herein specified.

Construction Methods:

Tree Removal: Removal of trees as indicated on the plans shall be performed by workman skilled in the area of tree removal under the supervision of a Connecticut Licensed Arborist. The Contractor shall mark all trees, shrubs, and plants to be removed in accordance with the plans and these specifications. The Engineer shall have 7 days to field review the markings and make any adjustments prior to the start of the clearing operation.

Trees and shrubs within the right-of-way or within any property owned by the Town of Glastonbury that are designated for removal must be posted as such by the Glastonbury Tree Warden (Mr. Greg Foran of the Parks and Recreation Department, 652-7686) for a period of 10 days prior to removal. **No trees or shrubs within the Town of Glastonbury right-of-way shall be cut or removed until such posting has been completed and subsequent approval given by the Tree Warden.**

In general, no trees, etc. in public streets and highways are to be cut or damaged in any way except as noted on the plans. Trees, bushes, and growing crops on other lands may be cut, removed, or trimmed only to the extent provided in the terms of the rights-of-way or access rights possessed by the Town, and also only within the limits and in the manner, if any, indicated by the Engineer or by the drawings or Special Conditions.

Tree Trimming: Trimming of trees by a Connecticut Licensed Arborist is included under this item as required for clearance of construction equipment and pedestrians below the tree canopy. When the canopy of a tree must be elevated for clearance above the proposed improvements, trimming shall be done around the entire circumference of the tree.

Tree Protection and Care of Property: The Contractor shall install high visibility construction fence at the drip line of the tree canopy as shown on the plans and as directed by the Engineer to protect existing trees that are not to be cut from damage during construction. The Engineer, at his sole discretion, may also direct the Contractor to enclose the trunks of trees adjacent to his work that are not to be cut with substantial wooden boxes of such height as may be necessary to protect them from injury from piled material, from equipment, from his operations, or otherwise due to his work. Excavating machinery and cranes shall be of suitable type and be operated with care to prevent injury to trees not to be cut, and particularly to overhanging branches and limbs.

Branches, limbs, and roots shall not be cut except by permission of the Engineer. All cutting shall be smoothly and neatly done without splitting or crushing. In case of cutting or unavoidable injury to branches, limbs, and trunks of trees, the cut or injured portions shall be neatly trimmed and covered with an application of grafting wax or tree-healing paint, as directed.

Cultivated hedges, shrubs, and plant that might be injured by the Contractor's operations shall be protected by suitable means or shall be dug up and temporarily replanted and maintained. After the construction operations have been substantially completed, they shall be replanted in their original positions and cared for until growth is re-established. If cultivated hedges, shrubs, and plants are injured to such a degree as to affect their growth or diminish their beauty or usefulness, they shall be replaced by items of kind and quality at least equal to the kind and quality existing at the start of the work.

On paved surfaces, the Contractor shall not use or operate tractors, bulldozers, or other power-operated equipment, the treads of wheels that are so shaped as to cut or otherwise injure such surfaces.

Clearing: From areas to be cleared, the Contractor shall cut or otherwise remove all trees, saplings, brush, vines, and other vegetable matter such as snags, sawdust, bark, etc., and refuse. The area to be cleared shall be confined to the width shown on the plans or as stipulated in the Proposal. Vines, brush, and similar undergrowth shall be cut as close to the ground as practicable. Trees may be cut leaving a longer stump to facilitate their removal by power-operated equipment. No trees shall be cut or trimmed unless they are so indicated on the drawings.

Clearing shall also include removal and disposal of all items shown on the plans to be removed, or directed by the Engineer to be removed as part of the project, including, but not limited to, removal and disposal of existing concrete sidewalk, concrete steps, drainage structures, fences, and any and all other structures or materials not specifically listed in the Bid Proposal but required to be removed to accomplish the work.

All road signs, mail boxes, etc., shall be removed and reset as directed.

Grubbing: Grubbing shall consist of the complete removal of all tree stumps and roots larger than two inches in diameter to a minimum depth of 12-inches below the subgrade surface. All excavations made below the finished surface by the removal of trees, stumps, etc. shall be filled with suitable material and thoroughly compacted in such a manner that its surface will conform to the surrounding surface.

Stump grinding shall be used for stump removal where the potential for damage to adjacent improvements or underground utilities exists due to the excavation of stumps, or as directed by the Engineer. The requirements for grubbing noted above shall also apply to stump grinding operations.

Disposal: All materials removed during trimming, tree removal, and clearing and grubbing operations shall be disposed of by the Contractor in a manner satisfactory to the Engineer.

Measurement and Payment: Except as provided otherwise in the Bid Proposal or Special Conditions, this work shall be paid for at the Contract Lump Sum Price for "Clearing and Grubbing", which price shall include protection of existing trees and vegetation, tree removal and tree trimming under the supervision of a Connecticut Licensed Arborist, clearing and grubbing within the limits of the work, stump grinding, removal and disposal of trees, roots, stumps, brush, concrete steps, and other objects, leveling of areas to accommodate the work, and all labor, materials, tools, and equipment necessary thereto.

**ITEM # 0202000A                      EARTH EXCAVATION**

**ITEM # 0202513A                      REMOVAL OF CONCRETE SIDEWALK**

General: This item shall conform to Section 2.02 ROADWAY EXCAVATION, FORMATION OF EMBANKMENT AND DISPOSAL OF SURPLUS MATERIAL, of the Form 816 amended as follows:

Section 2.02.05 of the Form 816 shall be amended as follows:

Basis of Payment:

Removal and disposal of existing drainage structures shall be paid for at the contract unit price as listed in the bid proposal for "Remove Existing Drainage Structure" as described elsewhere in these specifications.

Removal and disposal of existing concrete sidewalk slabs shall be paid for at the contract unit price per square yard for the item "Removal of Concrete Sidewalk." Sawcutting of concrete sidewalks shall not be measured for payment, but rather included in the contract unit price per square yard for "Removal of Concrete Sidewalk".

Other earth excavation necessary for sidewalk and driveway construction will not be measured for payment, but rather included in the unit cost for sidewalk or driveway construction as described elsewhere in these specifications.

Earth Excavation within the limits of full depth road construction shown on the plans shall be paid for at the contract unit price per cubic yard as listed in the bid proposal. The contract price for earth excavation shall include all labor equipment, materials, transportation, fuel, disposal, etc., for excavation of earth, on site relocation of earth products and transportation and/or disposal of surplus earth materials. All surplus earth materials shall be hauled off-site by the contractor and shall become property of the contractor. There shall be no separate payment for transportation or disposal of any surplus materials.

**ITEM # 0202100A                      ROCK EXCAVATION AND DISPOSAL**

General: The Contractor shall excavate rock (as defined below), if encountered, to the lines and grades indicated on the drawings or as directed, shall dispose of the excavated material, and shall furnish acceptable material for backfill in place of the excavated rock.

In general, rock in pipe trenches shall be excavated so as to be not less than 6 inches from the pipe after it has been laid. Before the pipe is laid, the trench shall be backfilled to the correct subgrade with thoroughly compacted, suitable material or, when so specified or indicated on the drawings, with the same material as that required for bedding the pipe, furnished and placed at the expense of the Contractor.

Definition of Rock: The work "rock", whenever used as the name of an excavated material or material to be excavated, shall mean only boulders and pieces of concrete or masonry exceeding one-half (½) cubic yard in volume, or solid ledge which, in the opinion of the Engineer, requires for its removal drilling, and blasting, wedging, sledging, barring, or breaking up with a power-operated tool. No soft or disintegrated rock that can be removed with a hand pick or power-operated excavator or shovel, no loose, shaken, or previously blasted rock or broken stone in rock filings or elsewhere, and no rock exterior to the maximum limits of measurement allowed that may fall into the excavation will be measured or allowed as "rock".

Construction Methods:

Excess Rock Excavation: If rock is excavated beyond the limits of payment indicated on the drawings, specified, or authorized in writing by the Engineer, the excess excavation, whether resulting from overbreakage or other causes, shall be backfilled by and at the expense of the Contractor as specified before in this Section.

In pipe trenches, excess excavation below the elevation of the top of the bedding cradle or envelope shall be filled with material of the same type, placed and compacted in the same manner as specified for the bedding, cradle, or envelope.

In excavations for structures, excess excavation in the rock beneath foundations shall be filled with concrete which shall be Class A or Class B, at the option of the Contractor. Other excess excavation shall be filled with earth as specified in the Section entitled "Backfilling Around Structures" under BACKFILLING AND CONSOLIDATION.

Blasting: If explosives are used, all requirements for transportation, use and storage of Local, State, and Federal laws and regulations must be complied with and all necessary permits and licenses obtained by the Contractor at his expense. Permits and licenses must be shown to the Engineer upon request. Permits are issued through the Town of Glastonbury Fire Marshalls Office, and may require a pre / post blast survey.

Explosives must be carefully transported, stored, handled, and used. The Contractor will keep on the job only such quantities of explosives as may be needed for the work underway and only during such time as they are being used. Explosives shall be stored in a secure manner in locked containers and separate from all tools. Caps and detonators shall be stored separately from other explosives. When the need for explosives is ended, all such material remaining on the job shall be promptly removed from the premises. Care must be taken that no explosives, caps, or detonators are stolen or get into the hands of unauthorized persons, or left unguarded where they may cause accidents.

Explosives shall be of such power and placed and used in such quantities as will not make the excavation unduly large or shatter unnecessarily the rock upon or against which the main or structure is to be built, or

injure adjacent persons or property, those portions of the new work or structure as may already be in place, or other adjacent pipes, ducts, or other structures. The quantity of explosives fired at one blast must be small enough and the tie for blasting selected to avoid undue annoyance to persons owning or occupying the premises near the work.

The rock must be completely matted when blasts are fired to prevent damage or injury to persons or property or the scattering of broken fragments on the adjacent ground. Adequate warning shall be given to all persons in the vicinity before any blast is discharged.

When blasting is required, the operation shall be conducted with such care as not to cause damage to any of the existing underground utilities. Should such occur, the cost of repairs shall be the sole responsibility of the Contractor.

The Contractor shall notify each public utility or others having structures in proximity to the site, and others who may be affected, of his intention to use explosives. Said notice shall be given in accordance with the applicable regulations therefore, and sufficiently in advance to enable the involved agencies/companies/persons and the Contractor to take such steps as may be necessary to protect life and property. Such notice shall not, in any way, relieve the Contractor of responsibility for any damage resulting from his blasting operations.

When in sufficiently close proximity to existing gas, water, sanitary, storm, or other utilities and structures, and all services connected thereto, the Contractor shall remove the rock by methods other than blasting, if necessary, in order to protect said utilities and their services from damage. Approved methods other than blasting are barring and wedging, jackhammer, drilling, rock jacks, or other such hand or machinery methods that will not damage the adjacent utility.

No explosives shall be brought into, stored, or used on the site of any job by the Contractor unless and until he shall have furnished the Engineer with a satisfactory Certificate of Insurance showing that the risks arising from the presence of and use of explosives, and from blasting, are included within the insurance provided by the Contractor to secure his obligations to the Town. Insurance should also cover damage to underground utilities or other underground facilities.

When blasting for trench excavation, each shot sequence shall begin sufficiently ahead of completed work to prevent damage to the completed work, which must be properly protected prior to each shot.

The provisions herein shall apply where soil formation resembles rock, whether in trench, structure, or general excavation, even if it is of such nature that it is not classified and paid for as rock excavation and, if so ordered by the Engineer, will apply to openings cut through masonry, nested boulders, or other materials not herein classified as rock.

Blasting Records: An accurate blasting log must be maintained continuously for the duration of the Contract. The log shall record, for each shot, the location, amount of holes, depth, spacing, exact date and time of the blast, amount of explosives per hole, and the number of caps used. In addition, a sketch showing displacement of direct and delay caps for each shot shall be recorded.

Test Blasting and Monitoring Program: The Contractor shall employ an acceptable, independent vibration/blasting consultant to conduct test blasting prior to production blasting to devise suitable blasting procedures for production blasting, and to monitor production blasting. The vibration/blasting consultant shall be a Registered Professional Engineer in the State of Connecticut and shall have a minimum of ten years experience as a vibration/blasting consultant. The Contractor shall submit the name of the vibration/blasting consultant to the Engineer prior to starting the work.

The purpose of the test blasting is to develop control procedures for production blasting so that no disturbance or damage shall be done to utilities, equipment, buildings, structures, groundwater wells, or the aquifer.

Based on the results of the test blasting, the vibration/blasting consultant shall develop a suitable blasting program and distance-quantity of explosive tables of the production blasting. The blasting program and the distance-quantity tables shall be submitted to the Engineer 21 days prior to the commencement of production blasting. All production blasting operations shall be in accordance with the blasting program.

The vibration/blasting consultant shall also perform continuous monitoring of all initial blasting operations and intermittent monitoring of subsequent blasting, as deemed necessary by the vibration/blasting consultant. Blasts shall be monitored with a minimum of two 3-component seismometers that record the entire particle velocity wave train and not just peak velocities. Accurate, legible seismometer records of all monitored blasts shall be obtained, and one copy of all blast records shall be submitted to the Engineer within seven days after blasting.

Wells: The Contractor's attention is directed to the existence of active groundwater supply wells near the area of construction. The Contractor shall locate all wells within or near the project area that could be affected by his operations.

The Contractor shall conduct his operations so that no disturbance or damage shall be done to the groundwater supply wells or to the aquifer from which they draw water. The aquifer is herein defined as underlying soil and rock formations within a distance of 1,500 feet from the wells and the groundwater within those formations.

The Contractor shall be fully responsible for determining the methods and controls necessary so that his construction operations do not disturb groundwater wells or the aquifer, and do not change the quality or quantity of water reaching the well.

If evidence of a change in well water quality or well yield, or disturbance or damage to any utility, equipment, building, or structure is observed or reported to the Contractor, he shall immediately notify the Engineer and all blasting operations shall be discontinued and the Contractor's vibration/blasting consultant shall recommend revised blasting procedures. The Contractor shall initiate the revised procedures, once approved by the Engineer, before blasting is continued.

The Contractor shall furnish potable water to any home where the well is disrupted or the water is declared unfit for human consumption. The water shall be supplied in such quantity as necessary to allow the homeowner to function on a normal day-to-day basis without any significant inconvenience or expense. The water shall be delivered as frequently as necessary to assure its freshness. The Contractor shall continue to furnish water until the problem is resolved.

The Contractor shall be fully responsible for the restoration or replacement of all water supply wells, utilities, equipment, buildings, or structures damaged by his operations at no cost to the Town.

Shattered Rock: If the rock below normal depth is shattered due to drilling or blasting operations of the Contractor and the Engineer considers such shattered rock to be unfit for foundations, the shattered rock shall be removed and the excavation shall be backfilled with concrete as required, except that in pipe trenches, screened gravel may be used for backfill, if approved. All such removal and backfilling shall be done by and at the expense of the Contractor.

Preparation of Rock Surfaces: Whenever so directed during the progress of the work, the Contractor shall remove all dirt and loose rock from designated areas and shall clean the surface of the rock thoroughly using steam to melt snow and ice, if necessary. Water in depressions shall then be removed, as required,



so that the whole surface of the designated area can be inspected to determine whether seams or other defects exist.

The surfaces of rock foundations shall be left sufficiently rough to bond well with the masonry and embankments to be built thereon and, if required, shall be cut to rough benches or steps.

Before any masonry or embankment is built on or against the rock, the rock shall be scrupulously freed from all vegetation, fragments, ice, snow, and other objectionable substances. Picking, barring, wedging, streams of water under sufficient pressure, stiff brushes, hammers, steam jets, and other effective means shall be used to accomplish this cleaning. All free water left on the surface of the rock shall be removed.

Removal of Boulders: Piles of boulders or loose rock encountered within the limits of earth embankments shall be removed to a suitable place of disposal.

Disposal of Excavated Rock: Excavated rock may be used in backfilling trenches subject to the following limitations:

Pieces of rock larger than permitted under the section entitled "Backfilling Pipe Trenches" shall not be used for this purpose.

The quantity of rock used as backfill in any location shall not be so great as to result in the formation of voids.

Rock backfill shall not be placed within 18 inches of the surface of the finished grade.

Surplus excavated rock shall be disposed of as specified for surplus excavated earth.

Backfilling Rock Excavations: Where the rock has been excavated and the excavation is to be backfilled, the backfilling above normal depth shall be done as specified L. If material suitable for backfilling is not available in sufficient quantity from other excavations, the Contractor shall, at his own expense, furnish suitable material from outside sources.

Compaction of Backfill Material: Consolidation of backfill material in a trench where rock has been blasted shall be obtained through the use of a water-jetting method, or as approved by the Engineer.

Measurement and Payment: Where rock (as defined in this Section) is encountered, it shall be stripped of the overlying material and the Engineer will measure the same. All rock excavated before the Engineer shall have examined it shall be estimated by the Engineer based on obvious evidence of rock.

This work shall be paid for at the contract unit price for "Rock Excavation" as listed in the bid proposal. The quantity of rock excavation to be paid for shall be the number of cubic yards of rock in place, as if measured before excavation, that would have been removed if the excavation had been made everywhere exactly to the lines of payment shown in the table entitled "Maximum Trench Widths for Various Pipe Sizes" as described in the Special Provision for Earth Trench Excavation.

At manholes, catch basins, or other structures, rock excavation will be paid for on lines 12 inches beyond the outermost dimension of the structure.

**ITEM # 0202451A**                      **TEST PIT EXCAVATION**

Description: Excavate and backfill a designated area to determine the exact location of utility facilities which are near a proposed foundation.

Materials:

Compacted Granular Fill: Article M.02.02  
Bituminous Concrete Materials: Article M.04

Construction Methods:

Keep affected utility owner apprised of proposed test pit excavation.

Excavate only as authorized and as directed by the Engineer. The size, depth and location will be as authorized by the Engineer.

If rock greater than 0.5 c.y. is encountered, the Engineer will determine if it must be removed and the method. Do not use explosives. See the pertinent construction methods of Section 2.02.03. When concrete must be removed, reinforced or not, it shall be considered, measured, and paid for as rock in foundation excavation.

If unsuitable backfill material is excavated, dispose as directed by the Engineer. Replace with suitable backfill and compact in accordance with Section 2.14.

Repair all damaged bituminous pavement in accordance with Section 4.06.03. Sawcut the edges to neat lines if there will be no subsequent excavation at the test pit for a foundation.

Method of Measurement:

Test pit excavation will be measured at the contract unit price per cubic yard (cubic meter) for the material actually removed from within the limits specified as directed by the engineer.

When necessary, rock in foundation excavation will be measured at the contract price per vertical foot (vertical meter) for the rock actually removed in accordance with Article 10.02.04.

Basis of Payment:

This work will be paid for at the contract unit price per cubic yard for "Test Pit Excavation", which price shall include excavation, unsuitable material disposal, compacted backfill, bituminous pavement, sawcut, pavement repair, all utility costs, all equipment, tools, labor and work incidental thereto. The volume excludes the volume of material that is measured as Rock In Foundation Excavation.

**ITEM # 0202553A                      SET MONUMENT IN CONCRETE SIDEWALK**

Description: This item shall consist of the installation of a Town-provided concrete survey monument into a new concrete sidewalk at the precise location indicated by the Town. The Town survey crew will provide offset staking for the purposes of locating the street line monument within the proposed concrete sidewalk.

Materials: Materials for this work shall conform to the following requirements:

Concrete survey monuments shall be provided by the Town.

Expansion joint material shall conform to the requirements described in the Special Provision for Concrete Sidewalks.

Construction Methods:

The Contractor shall excavate as required to accommodate the proposed concrete monument. Formwork for the proposed concrete sidewalk shall be modified as required to accommodate the survey monument at the location indicated by the Town. The survey monument shall be set to be flush with the surface of the proposed sidewalk. The concrete sidewalk shall then be poured around the concrete monument while the surface of the monument is protected.

Basis of Payment: This work will be paid for at the contract unit price for each "Set Monument in Sidewalk" complete in place, which price shall include all excavation as specified above, backfill, disposal of surplus material, modification of sidewalk formwork, and all equipment, tools, labor and materials incidental thereto.

**ITEM # 0204503A                      TRENCH DEWATERING**

General: To ensure proper conditions at all time during construction, the Contractor shall provide and maintain ample means and devices (including spare units kept ready for immediate use in case of breakdown) with which to intercept and/or remove promptly and dispose properly of all water entering trenches and other excavations. Such excavations shall be kept dry until the structures, pipes, and appurtenances to be built therein have been completed to such extent that they will not be floated or otherwise damaged.

All water pumped or drained from the work shall be disposed of in a suitable manner without undue interference with other work, damage to pavements, other surfaces, or property. Suitable temporary pipes, flumes, or channels shall be provided for water that may flow along or across the site of the work.

Construction Methods:

Temporary Underdrains: Temporary Underdrains, if used, shall be laid in trenches beneath the grade of the structure. Trenches shall be of suitable dimensions to provide room for the chosen size of underdrain and its surrounding gravel. Underdrain pipe shall be acceptable PVC or ADS pipe of standard thickness. Sewer pipe of the quality known as "seconds" will be acceptable.

Underdrains, if used, shall be laid at an approved distance below the bottom of the normal excavation wrapped in Mirafi 140 or equal as outlined in Section 409.05 of these specifications, and entirely surrounded by graded gravel or crushed stone to prevent the admission of sand or other soil into the underdrains. The distance between the top of the bell of the underdrain pipe shall be at least three (3) inches unless otherwise permitted. The space between the underdrain and the pipe or structure shall be filled and crushed stone which shall be rammed, if necessary, and left with a surface suitable for laying the pipe or building the structure.

Drainage Wellpoint System: If required, the Contractor shall dewater the excavations by means of an efficient drainage system which will drain the soil and prevent saturated soil from flowing into the excavation. The wellpoints shall be designed especially for this type of service. The pumping unit shall be designed for use with the wellpoints and shall be capable of maintaining a high vacuum and of handling large volumes of air and water at the same time.

If required, the installation of the wellpoints and pump shall be done under the supervision of a competent representative of the manufacturer. The Contractor shall do all special work such as surrounding the wellpoints with sand or gravel or other work which is necessary for the wellpoint system to operate for the successful dewatering of the excavations.

Payment: This item will not be paid for separately. Rather, payment for trench dewatering shall be included in the unit price of the item associated therewith.

**ITEM # 0205001A                      EARTH TRENCH EXCAVATION**

General: The Contractor shall make excavations of normal depth in earth for trenches and structures; shall backfill such excavations to the extent necessary; shall furnish the necessary material and construct embankments and fills; and shall make miscellaneous earth excavations and do miscellaneous grading. All such work shall be done as indicated on the drawings and as herein specified.

The program of excavation, dewatering, sheeting and bracing shall be carried out in such manner as to eliminate all possibility of undermining or disturbing the foundations of existing structures or of work previously completed under this contract.

Excavation in general shall be in open trenches. Tunneling shall be done only to pass under obstructions such as pipes or duct or only as indicated on contract drawings, or in Special Provisions, or on written permission of the Engineer, and then only in accordance with those sections hereof which describe tunnel excavation, and subject to such further conditions as may have been described by drawings, Special Provisions, or as the Engineer may specify.

The Contractor shall make excavations in such manner and to such widths as will give suitable room for building the structures or laying and jointing the piping; shall furnish and place all sheeting, bracing, and supports; shall do all coffer damming, pumping and draining; and shall render the bottom of the excavations firm and dry and acceptable in all respects.

Construction Methods:

Trench Excavation: Where pipe is to be laid in gravel bedding or concrete cradle, the trench may be excavated by machinery to or to just below, the designated subgrade, provided that the material remaining at the bottom of the trench is no more than slightly disturbed.

Where pipe is to be laid directly on the trench bottom, the lower part of trenches in earth shall not be excavated to subgrade by machinery, but, just before the pipe is to be placed, the last of the material to be excavated shall be removed by means of hand tools to form a flat or shaped bottom, true to grade, so that the pipe will have a uniform and continuous bearing and support on firm and undisturbed material between joints except for limited areas where the use of pipe slings may have disturbed the bottom.

Depth of Trench: Trenches shall be excavated to such depths as will permit the pipe to be laid at the elevations, slopes or depths of cover indicated on the drawings, and at uniform slopes between indicated elevations.

Width of Trench: The methods and equipment used for excavation must be adapted to the conditions at the site and the dimensions of the required trench. The width of ground or street surfaces cut or disturbed shall, in general, be kept as small as practicable to accommodate the work and shall not be widened by scraping or loosening materials from the sides. Every effort shall be made to keep the sides of the trenches firm and undisturbed until backfilling has been completed and consolidated.

Width of pipe trenches shall be wide enough to provide sufficient space for shoring, for foundations, for drainage, for laying, jointing, inspecting, and backfilling of sides of pipe, or for building the required structures, and as near as feasible to the above described minimums, in order to reduce the load of backfill upon the top of the sewer; to provide lateral support for the fill and haunching on the sides of the pipe, and to insure that the pipe will not be pushed out of line while placing backfill.

The maximum permissible trench width to be paid by the Town varies with the diameter of the pipe (see table 403-1). Where the Contractor chooses not to use trench supports, the Contractor will still be paid as per maximum trench widths or actual trench width, whichever is the least.

Excavation for Special Foundations: Where concrete, stone or underdrain is required or ordered, excavation shall be carried down to the depth and lines required for such foundation or underdrain. If required by contract drawings or Special Provisions as part of the structure and included in the price, no additional payment for this additional excavation, as excavation, will be made. If the foundation is paid by the cubic yard or other specific item of proposal, such price for foundation shall include excavation therefore. Excavation for underdrain is included in price for underdrain.

Where the plans, Proposal or Special Provisions indicate certain foundations, they will be constructed and paid for as indicated.

Where the soil in subgrade is found to be soft, loose or freshly-filled earth, or unstable or unsuitable as a base for the proposed sewer or structure, the Engineer may, in his discretion, order it excavated to such depth and width as he may deem proper and replaced with gravel, crushed stone, concrete, plank or similar materials as he may direct.

If the excavation for foundation is made wider or deeper than required or ordered, or if excavation for concrete on sides of pipe is made wider than required or ordered, then no additional payment for the additional quantities of excavation or for additional foundation or side filling materials will be made, if being assumed that the added space was excavated for the convenience of, or by error of, the contractor.

Length of Trench and Space Occupied: Trenches must be constructed with a minimum of inconvenience and danger to the public and all other parties. To that end, the length of trench opened at any time, from point where ground is being broken to completed backfill and temporary surfacing, and also the amount of space in streets or public and private lands occupied by trench soil banks, equipment and supplies, shall to exceed the space or spaces considered reasonably necessary and expedient by the Engineer. In determining the length of open trench, the space for equipment, materials, supplies, etc. needed, the Engineer will consider the nature of the street or land where work is being done, depth and width of trench, types and methods of construction and equipment being used, inconvenience to the public or to private parties, possible dangers, limits or rights-of-way and other proper matters.

The Contractor must keep streets and premises near the work free from unnecessary obstructions, debris, etc. The Engineer may, at any time order all equipment, materials, surplus from excavations, debris, etc., lying outside reasonable limits of space, promptly removed; and should the Contractor fail to remove such materials within three days after notice to remove same, the Engineer may cause any part or all of such materials to be removed by such persons as he may employ, at the Contractor's expense, and may deduct the costs thereof from payment which may be or may become due to the contractor under this Contract. In any cases when public safety urgently demands it, the Engineer may cause such materials to be removed without prior notice.

Trenches shall be excavated with approximately vertical sides between the elevation of the center of the pipe and an elevation one foot above the top of the pipe.

Dimensions of Trenches: Trenches shall be excavated to the lines indicated on contract drawings or as described for any particular structure by any contract document. In general, room shall be allowed for installing the pipe or other structure, for making and inspecting joints in pipe, for placing and compacting fill around and on both sides of pipe, for draining and pumping as needed, for removal of unsuitable materials, and for any other purpose incidental to the fulfillment of the Contract and these specifications.

Care must be taken to excavate to correct line, grade and width at all points.

In general, sides of trenches must be not less than four inches from outside of barrel of all pipe eight inches or less in size, six inches from outside of barrel of pipe ten inches or larger in size, or as shown by contract drawings. Except as otherwise provided, excavation shall conform closely to the form and grade of the bottom of the pipe or foundation required. To accomplish this, the Engineer may require that no earth shall be excavated by machinery nearer than six inches to the finished subgrade, and the last six inches of excavation in earth shall be carefully removed by hand labor to the exact lines and grade required, immediately prior to laying pipe or underdrain or building bottom of structure.

Maximum trench width for various pipe sizes are described below. Where the Contractor chooses not to use trench supports the Contractor will still be paid for any restoration work specified elsewhere in the contract as per maximum trench widths described below.

MAXIMUM TRENCH WIDTHS FOR VARIOUS PIPE SIZES

Size Pipe Nominal Inside Diameter	Maximum Width of Trench
6"	2.5 Feet
8"	4.0 Feet
10"	4.0 Feet
12"	4.0 Feet
15"	4.0 Feet
18"	4.0 Feet
21"	4.3 Feet
24"	4.5 Feet
27"	4.8 Feet
30"	5.1 Feet
33"	5.4 Feet
36"	5.7 Feet
39"	5.9 Feet
42"	6.3 Feet

Extent of Open Excavation: The extent of excavation open at any one time will be controlled by the conditions, but shall always be confined to the limits prescribed by the Engineer. At no time shall the extend of the open excavation go beyond two structures.

Trench Excavation in Fill: If pipe is to be laid in embankments or other recently filled material, the material shall first be placed to the top of the fill or to a height of at least one foot above the top of the pipe, whichever is the lesser. Particular care shall be taken to ensure maximum consolidation of material under the pipe location. The pipe trench shall be excavated as though in undisturbed material.

Unauthorized Excavation: If the bottom of any excavation is taken out beyond the limits indicated or prescribed, the resulting void shall be backfilled at the Contractor's expense with 3/4" crushed stone if the excavation was for a pipeline not having a concrete cradle or encasement, or with Class B concrete if the excavation was for a masonry structure.

Cutting of Pavement: When the trench lies within a paved area, the trench shall be cut with an approved tool. All cuts shall be made to straight lines and shall be parallel and/or perpendicular to the center line of the trench.

Bridging Trenches: The Contractor shall, at no cost, provide suitable and safe bridges and other crossings where required for the accommodation of travel, and to provide access to private property during construction, and shall remove said structures thereafter.

Obstacles: Some obstructions, obstacles, or difficulties in the path of the work anticipated, or in the performance of the work, may have been indicated by drawings, Special Provisions, or in other contract documents. The omission of any indication or mention of any obstruction, obstacle or difficulty which a reasonable and careful contractor, bidder, or estimator might have anticipated, or any question as to adequacy of such indication as given, shall not entitle the Contractor to any extra or additional compensation for any loss or expense occasioned directly or indirectly by such obstruction, etc., not to any extension of time or waiver of any requirement of the Contract and Specifications. The Contractor shall be understood to have entered into the Contract with full knowledge that in any work involving excavation, operation in public highways or adjacent to other developments, some unforeseen obstacle, difficulties, unforeseen soil or ground water conditions, etc., may be encountered, and that the Contractor has included in the bid and contract obligations the assumptions of the risks and cost to which such obstacles, etc. may subject the bid.

The Town will make arrangements for clearance or avoidance of permanent obstruction by pipes and structures of public utilities and of public bodies, except as otherwise indicated on drawings or contract documents, where such obstruction is found in the space to be occupied by the pipe or structure to be built under the Contract. The Town will not assume the cost of temporary removal, support, protection, etc. of pipes, poles, and other structures which do not occupy the space to be occupied by the pipe or structure to be built for the Town, where removal, support, protection, etc. of such pipes, poles or structures is desired for the convenience of, or to save expense to, or to accommodate the equipment of the Contractor.

Ends of Certain Pipes to be Sealed: If any pipe, drain, culvert, connection or similar conduit is encountered and cut off or cut through incidental to the construction of the work, and if the said drain, etc. is not to continue to function or be used, the open end or ends of such pipes shall be securely and tightly closed by an adequate cover or bulkhead as directed by the Engineer. Except as a specific price for such closings was fixed in the Proposal, the cost of such covers, bulkheads, and the setting of them shall have been included in the price of prices bid for various other portions of the work in the Proposal and no additional payment will be made therefore.

In removing existing pipes or other structures, the Contractor shall use care to avoid damage to materials, and the Engineer shall include for payment only those new materials which are necessary to replace those unavoidably damaged.

The structures to which the provisions of the preceding three paragraphs shall apply include pipes, wires, and other structures which (a) are not indicated on the drawings or otherwise provided for, (b) encroach upon or are encountered near the substantially parallel to the edge of the excavation, and (c) in the opinion of the Engineer will impede progress to such an extent that satisfactory construction cannot proceed until they have been changed in location, removed (to be later restored), or replaced.

When fences interfere with the Contractor's operations, the Contractor shall remove and (unless otherwise specified) later restore them to at least as good condition as that in which they were found immediately before the work was begun, all without additional compensation. The restoration of fences shall be done as promptly as possible and not left until the end of the construction period.

Excavation Near Existing Structures: Attention is directed to the fact that there are pipes, drains, and other utilities in certain locations. Some of these have been indicated on the drawings, but no attempt has been made to show all of the services, and the completeness or accuracy of the information given is not guaranteed.



As the excavation approaches pipes, conduits, or other underground structures, digging by machinery shall be discontinued and the excavation shall be done by means of hand tools, as directed. Such manual excavation, when incidental to normal excavation, shall be included in the work to be done under items involving normal excavation.

Where determination of the exact location of a pipe or other underground structure is necessary for doing the work properly, the Contractor may be required to excavate test pits to determine such locations. When such test pits may be properly considered as incidental to other excavation, the Contractor shall receive no additional compensation, the work being understood to be included as a part of the excavation. When the Engineer orders test pits beyond the limits of excavation considered as part of the work, such test pits shall be paid for as specified under MEASUREMENT AND PAYMENT.

Protection of Existing Structures: All existing pipes, poles, wires, fences, curbing, property-line markers, and other structures which the Engineer decides must be preserved in place without being temporarily or permanently relocated shall be carefully supported and protected from injury by the Contractor. Should such items be injured, they shall be restored by the Contractor, without compensation therefore, to at least as good condition as that in which they were found immediately before the work was begun.

Relocation and Replacement of Existing Structures: Whenever the Contractor encounters certain existing structures as described below and is so ordered in writing, the Contractor shall do the whole or such portions of the work as he may be directed, to change the location of, remove and later restore, replace such structures, or to assist the owner thereof in so doing. For all such work, the Contractor shall be paid under such items of work as may be applicable, otherwise as Extra Work.

Backfilling and Consolidation: In general, and unless other material is indicated on the drawings or specified, material used for backfilling trenches and excavations around structures shall be suitable material which was removed in the course of making the construction excavations.

Frozen materials shall not be placed in the backfill nor shall backfill be placed upon frozen material. Previously frozen material shall be removed, or shall be otherwise treated as required before new backfill is placed.

Backfilling around Structures: The Contractor shall not place backfill against or on structures until they have attained sufficient strength to support the loads (including construction loads) to which they will be subjected without distortion, cracking, or other damage. As soon as practical after the structures are structurally adequate and other necessary work has been done, special leakage tests, if required, shall be made. Promptly after the completion of such tests, the backfilling shall be started and then shall proceed until its completion. The best of the excavated materials shall be used in backfilling within two feet of the structure. Unequal soil pressures shall be avoided by depositing the material evenly around the structure.

Backfilling Pipe Trenches: As soon as practicable after the pipes have been laid and the joints have acquired a suitable degree of hardness, if applicable, or the structures have been built and are structurally adequate to support the loads, including construction loads to which they will be subjected, the backfilling shall be started, and thereafter it shall proceed until its completion in accordance with pipe manufacturer recommendations.

With the exception mentioned below in this paragraph, trenches shall not be backfilled at pipe joints until after that section of the pipeline has successfully passed any specified tests required. Should the contractor wish to minimize the maintenance of lights and barricades and the obstruction of traffic, the contractor may, at his own risk, backfill the entire trench, omitting or including backfill at joints as soon as practicable after the joints have acquired a suitable degree of hardness, if applicable, and the related structures have acquired a suitable degree of strength. The contractor shall, however, be responsible for removing and later

replacing such backfill at no cost should the contractor be ordered to do so in order to locate and repair or replace leaking or defective joints or pipe.

Materials: The nature of the materials will govern both their acceptability for backfill and the methods best suited for their placement and compaction in the backfill. The materials and methods shall both be subject to the approval and direction of the Engineer. No stone or rock fragment larger than 12 inches in greatest dimension shall be placed in the backfill nor shall large masses of backfill material be dropped into the trench in such a manner as to endanger the pipeline. If necessary, a timber grillage shall be used to break the fall of material dropped from a height of more than five feet. Pieces of bituminous pavement shall be excluded from the backfill unless their use is expressly permitted, in which case they shall be broken up as directed.

Ho Pac Trench Consolidation: Where the trench backfill is consolidated by the "Ho Pac" method and the depth of the trench from the road or ground surface to the top of the pipe exceeds ten feet, the trench backfill shall be placed and consolidated in two lifts of equal depth.

The approved backfill material shall be placed and compacted at a moisture content between four and eight percent (based on dry density, by weight), or with two percent of the optimum moisture content as determined by the moisture density relationship test specified in ASTM D 1557, at the option of the Engineer. Compaction shall be by a "Ho Pac" vibratory compactor or approved equal, operating at a frequency between ten and 40 Hertz, placed directly on the backfill surface, and applied with the maximum practical force applicable by the backhoe to which it is attached. Compaction effort shall be continued until no further visible settlement occurs.

Miscellaneous Requirements: Whatever method of compacting backfill is used, care shall be taken that stones and lumps shall not become nested and that all voids between stones shall be completely filled with fine material. Only approved quantities of stone and rock fragments shall be used in the backfill. The Contractor shall, as part of the work done under the items involving earth excavation and rock excavation as appropriate, furnish and place all other necessary backfill material.

All voids left by the removal of sheeting shall be completely backfilled with suitable materials, thoroughly compacted.

Where required, excavated material which is acceptable to the Engineer for surfacing or pavement sub base shall be placed at the top of the backfill to such depths as may be specified elsewhere or as directed. The surface shall be brought to the required grade and stones raked out and removed.

Embankments Over Pipe: Where the top of the pipe is less than three feet below the surface of the ground, additional fill shall be placed to form an embankment to cover and protect the pipe. The top of such embankment shall not be less than three feet above the top of the pipe and not less than one foot wider than the outside diameter of the pipe, with side slopes no steeper than one and one half horizontal to vertical, or of such section as may have been indicated by drawings. Such embankments shall be made of suitable dry earth, well compacted. Embankments must be maintained to the full required dimensions during the maintenance period of the Contract, and any settlement, washout, or deficiency occurring or found during that time shall be rectified and embankments brought up to the required height, width and slopes.

In general, such embankments may be made with materials excavated on the job and not used for backfill elsewhere. Should there not be sufficient surplus material for embankments, or should it be unsuitable or inconveniently located, the Contractor shall secure and provide sufficient suitable material. In any case, where the Town has provided borrow pits from which the Contractor may obtain filling material, the Contractor must conform to the conditions for excavating and moving such material as established by acts of the Town in obtaining such rights, and by indications on drawings or in other contract documents.

Openings through embankments for the passage of water and other purposes will be provided as indicated on drawings or elsewhere, or as ordered.

Grass shall be seeded or turf placed on embankments if, where, and as provided in contract documents. In general, if grassing is not required, the Contractor may, at his option, grass embankments to facilitate his maintenance. The Engineer may order grassing where not otherwise required under the general provisions for additional work if he deems proper.

Care shall be taken that sewer and appurtenances are not damaged by equipment or methods used for making and maintaining embankments.

Except as specific provisions may have been made in the Proposal for a particular contract, no payment other than prices bid for pipe will be paid for building and maintaining embankments or securing material therefore.

If, however, a price per cubic yard was established by the Proposal for filling material placed in embankments and/or in fills at side of embankment to avoid the formation of depressions there, the quantity of such filling material will be estimated and paid as the actual quantity placed, up to, but not exceeding the lines or sections required, measured after the embankment or fill has been made.

Material for Filling and Embankments: Approved selected materials available from the excavations and not required for backfill around pipes or against structures may be used for filling and building embankments, except as otherwise specified. Material needed in addition to that available from construction operations shall be obtained from approved gravel banks or other approved deposits. The Contractor shall furnish, at no cost, all borrowed material needed on the work.

All material, whether from the excavations or from borrow, shall be of such nature that after it has been placed and properly compacted it will make a dense, stable fill. It shall not contain vegetation, masses of roots, individual roots more than 18 inches long or more than one half inch in diameter, stones over six inches in diameter, or porous matter. Organic matter shall not exceed minor quantities and shall be well distributed.

Preparation of Subgrade: The Contractor shall remove loam and topsoil, loose vegetable matter, stumps, large roots, etc. from areas upon which embankments will be built or material will be placed for grading. The subgrade shall be shaped as indicated on the drawings and shall be so prepared by forking, furrowing, or plowing so that the first layer of the new material placed thereon will be well bonded to it.

Placing and Compacting Material: After the subgrade has been prepared as hereinbefore specified, the material shall be placed thereon and built up in successive layers until it has reached the required elevation.

Layers shall not exceed 12 inches in thickness before compaction. In embankments at structures, the layers shall have a slight downward slope away from the structure. In other embankments, the layers shall be slightly dished toward the center. In general, the finer and less pervious materials shall be placed against the structures or in the center, and the coarser and more pervious materials, upon the outer parts of embankments.

Each layer of material shall be compacted by the use of approved rollers or other approved means so as to secure a dense, stable and thoroughly compacted mass. At such points as cannot be reached by mobile mechanical equipment, the materials shall be thoroughly compacted by the use of suitable power driven tampers.

Previously placed or new materials shall be moistened by sprinkling, if required, to ensure proper bond and compaction. No compacting shall be done when the material is too wet, from either rain or too great an application of water, to compact it properly. At such times, the work shall be suspended until the previously placed and new materials have dried out sufficiently to permit proper compaction.

Payment: This item will not be paid for separately. Rather, payment for earth trench excavation, backfilling, and the disposal of surplus excavated material shall be included in the unit price or lump sum price of the item associated therewith.

**ITEM # 0212000A                      SUBBASE**

This item shall conform to Section 2.12 SUBBASE, of the Form 816, amended as follows:

Materials: The material for this item shall conform to the requirements of Article M.02.01-Granular Fill, except that reclaimed miscellaneous aggregate shall not be used.

**ITEM # 0212300A                      PROCESSED STONE BASE**

This item shall conform to Section 3.04 PROCESSED AGGREGATE BASE, of the Form 816, amended as follows:

Materials: The material for this item shall conform to the requirements of Article M.05.01, except that coarse aggregate shall be broken stone, and fine aggregate shall be stone sand, screenings, or a combination thereof.

NOTE: Basis of payment for this item shall include fine grading prior to paving. No separate payment shall be provided for such work.

**ITEM # 0219001A                      SEDIMENT CONTROL SACK**

General: This work shall consist of furnishing, installing, maintaining, and removing a sedimentation control sack for control of sediment entering catch basins within the project area as directed by the Engineer or as shown on the contract drawings.

Materials: Sediment control sacks shall be Siltsack® as manufactured by SI® Geosolutions or approved equal, and shall be manufactured from a specially designed woven polypropylene geotextile.

The sediment control sack shall be manufactured to fit the opening of the catch basin or drop inlet to be protected. Sediment control sack shall have the following features: two dump straps attached at the bottom to facilitate emptying; lifting loops shall be included as an integral part of the system to be used to lift the sedimentation control sack from the basin; sediment control sack shall have a restraint cord approximately halfway up the sack to keep the sides away from the catch basin walls, this yellow cord is also a visual means of indicating when the sack should be emptied. Once the strap is covered with sediment, sediment control sack should be emptied, cleaned and placed back into the basin.

Construction Sequence: To install the sediment control sack in the catch basin, remove the grate and place the sack in the opening. Hold out approximately six inches of the sack outside the frame. This is the area of the lifting straps. Replace the grate to hold the sack in place.

When the restraint cord is no longer visible, the sediment control sack is full and should be emptied.

To remove the sediment control sack, take two pieces of 1" diameter rebar and place through the lifting loops on each side of the sack.

To empty the sediment control sack, place it where the contents will be collected. Place the rebar through the lift straps (connected to the bottom of the sack) and lift. This will turn the sedimentation control sack inside out and empty the contents. Clean out and rinse. Return the sedimentation control sack to its original shape and place back in the basin.

The sediment control sack is reusable. Once the construction cycle is complete, the sedimentation control sack shall be removed from the basin and cleaned. The sedimentation control sack shall then be provided to the Town for re-use.

Basis of Payment: Sediment control sacks shall be paid for as a unit for each sedimentation control sack provided and installed. Maintenance of the sediment control sacks and cleaning after completion of construction as described herein shall also to be included in this bid price.

**ITEM # 406010-1 BITUMINOUS CONCRETE CLASS 1**

**ITEM # 406010-4 BITUMINOUS CONCRETE CLASS 4**

Description: Where reference is made to bituminous concrete, it shall also refer to hot-mix asphalt (HMA) mixtures using the Marshall or Superpave mix-design method.

Work under this section shall consist of the production, delivery and placement of a non-segregated, smooth and dense bituminous concrete mixture brought to proper grade and cross section. This section shall also include the method and construction of longitudinal joints. The Contractor shall furnish Quality Control Plans for both plant production and placement of HMA mixtures.

The terms listed below as used in this specification are defined as:

*Course:* A lift or multiple lifts comprised of the same HMA mixture placed as part of the pavement structure.

*Dispute Resolution:* A procedure used to resolve conflicts resulting from discrepancies between the Engineer and the Contractor's density results that may affect payment.

*Hot Mix Asphalt (HMA):* A bituminous concrete mixture.

*Disintegration:* Wearing away or fragmentation of the pavement. Disintegration will be evident in the following forms: Polishing, weathering-oxidizing, scaling, spalling, raveling, potholes or loss of material.

*Lift:* A single HMA mixture placed at a defined thickness.

*Marshall:* A HMA mixture design designated as "Bituminous Concrete Class ( )."

*Superpave:* A HMA mixture design designated as "HMA S\*." Where "S" indicates Superpave and \* indicates the sieve related to the nominal maximum aggregate size of the mix. For example Superpave 0.50 inch is now designated as HMA S0.5.

*Segregation:* A non-uniform distribution of a HMA mixture in terms of volumetrics, gradation or temperature.

*Quality Assurance (QA):* All those planned and systematic actions necessary to provide confidence that a product or facility will perform as designed.

*Quality Control (QC):* The sum total of activities performed by the vendor (producer, manufacturer, and contractor) to ensure that a product meets contract specification requirements.

Materials: All materials shall conform to the requirements of Section M.04 of the Form 816, (latest edition) as amended and available on the Connecticut Department of Transportation webs site.

1. Materials Supply: The HMA mixture must be from one source of supply and originate from one HMA Plant unless authorized by the Engineer.

2. Recycle Option: The Contractor has the option of recycling reclaimed asphalt pavement (RAP) or Crushed Recycled Container Glass (CRCG) in HMA mixtures in accordance with Section M.04. CRCG shall not be used in the final lift of the surface course.



Construction Methods:

1. Material Documentation: All vendors producing bituminous concrete must have their truck-weighing scales, storage scales, and mixing plant automated to provide a detailed ticket.

Delivery tickets must include the following information:

State of Connecticut printed on ticket.

Name of producer, identification of plant, and specific storage bin (silo) if used.

Date and time of day.

Mixture Designation (If RAP is used, the plant printouts shall include RAP dry weight, percentage and daily moisture content.) Class 3 mixtures for machine-placed curbing must state "curb mix only".

Net weight of mixture loaded into truck (When RAP is used, RAP moisture shall be excluded from mixture net weight).

Gross weight (Either equal to the net weight plus the tare weight or the loaded scale weight).

Tare weight of truck – Daily scale weight.

Project number, purchase order number, name of contractor (if contractor other than producer).

Truck number for specific identification of truck.

Individual aggregate, RAP, and virgin asphalt high/target/low weights shall be printed on batch plant tickets (For drum plants and silo loadings, the plant printouts shall be printed out at 5 minute intervals maintained by the vendor for a period of three years after the completion of the project).

The net weight of mixture loaded into the truck must be equal to the cumulative measured weight of its components.

The Contractor must notify the Engineer immediately if, during the production day, there is a malfunction of the weighing or recording system in the automated plant or truck-weighing scales. Manually written tickets containing all required information will be allowed for one hour, but for no longer, provided that each load is weighed on State-approved scales. At the Engineer's sole discretion, trucks may be approved to leave the plant if a State inspector is present to monitor weighing. If such a malfunction is not fixed within forty-eight hours, mixture will not be approved to leave the plant until the system is fixed to the Engineer's satisfaction. No damages will be considered should the State be unable to provide an inspector at the plant.

The State reserves the right to have an inspector present to monitor batching and /or weighing operations.

2. Transportation of Mixture: Trucks with loads of bituminous concrete being delivered to State projects must not exceed the statutory or permitted load limits referred to as gross vehicle weight (GVW). The Contractor shall furnish a list of all vehicles and allowable weights transporting mixture.

The State reserves the right to check the gross and tare weight of any delivery truck. A variation of 0.4 percent or less in the gross or tare weight shown on the delivery ticket and the certified scale weight shall be considered evidence that the weight shown on the delivery ticket is correct. If the gross or tare weight varies from that shown on the delivery ticket by more than 0.4 percent, the Engineer will recalculate the net weight. The Contractor shall take action to correct discrepancy to the satisfaction of the Engineer.

If a truck delivers mixture to the project and the ticket indicates that the truck is overweight, the load will not be rejected but a "Measured Weight Adjustment" will be taken in accordance with Section 112.4.

The mixture shall be transported from the mixing plant in trucks that have previously been cleaned of all foreign material and that have no gaps through which mixture might inadvertently escape. The use of kerosene, gasoline, fuel oil, or similar products for the coating of the inside of truck bodies is prohibited.

Truck body coating and cleaning agents must not have a deleterious effect on the transported mixture. When acceptable coating or agents are applied, truck bodies shall be raised immediately prior to loading to

remove any excess agent in an environmentally acceptable manner. The Contractor shall take care in loading trucks uniformly so that segregation is minimized.

Loaded trucks shall be tightly covered with waterproof covers acceptable to the Engineer. Mesh covers are prohibited. The front and rear of the cover must be fastened to minimize air infiltration. The Contractor shall assure that all trucks are in conformance with this specification. Trucks found not to be in conformance shall not be allowed to be loaded until re-inspected to the satisfaction of the Engineer.

3. Paving Equipment: The Contractor shall have the necessary paving and compaction equipment at the project site to perform the work. All equipment shall be in good working order and any equipment that is worn, defective or inadequate for performance of the work shall be repaired or replaced by the Contractor to the satisfaction of the Engineer. The use of solvents or fuel oil as a release agent on any paving equipment (i.e., rollers, pavers, transfer devices, etc.) is strictly prohibited.

Refueling of equipment is prohibited in any location on the paving project where fuel might come in contact with bituminous concrete mixtures already placed or to be placed. Solvents for use in cleaning mechanical equipment or hand tools shall be stored clear of areas paved or to be paved. Before any such equipment and tools are cleaned, they shall be moved off the paved or to be paved area; and they shall not be returned for use until after they have been allowed to dry.

Pavers: Each paver shall have a receiving hopper with sufficient capacity to provide for a uniform spreading operation and a distribution system that places the mix uniformly, without segregation. The paver shall be equipped with and use a vibratory screed system with heaters or burners. The screed system shall be capable of producing a finished surface of the required evenness and texture without tearing, shoving, or gouging the mixture. Pavers with extendible screed units as part of the system shall have auger extensions and tunnel extenders as necessary. Automatic screed controls for grade and slope shall be used at all times unless otherwise authorized by the Engineer. The controls shall automatically adjust the screed to compensate for irregularities in the preceding course or existing base. The controls shall maintain the proper transverse slope and be readily adjustable, and shall operate from a fixed or moving reference such as a grade wire or floating beam.

Rollers: All rollers shall be self-propelled and designed for compaction of bituminous concrete. Roller types shall include steel-wheeled, pneumatic or a combination thereof and may be capable of operating in a static or dynamic mode. Rollers that operate in a dynamic mode shall have drums that use a vibratory or oscillatory system or combination of. The vibratory system achieves compaction through vertical amplitude forces. Rollers with this system shall be equipped with indicators that provide the operator with amplitude, frequency and speed settings/readouts to measure the impacts per foot during the compaction process. The oscillatory system achieves compaction through horizontal shear forces. Rollers with this system shall be equipped with frequency indicators. Rollers can operate in the dynamic mode using the oscillatory system on concrete structures such as bridges and catch basins if at the lowest frequency setting.

Pneumatic tire rollers shall be self-propelled and equipped with wide-tread compaction tires capable of exerting an average contact pressure from 60 to 90 pounds per square inch uniformly over the surface, adjusting ballast and tire inflation pressure as required. The Contractor shall furnish evidence regarding tire size; pressure and loading to confirm that the proper contact pressure is being developed and that the loading and contact pressure are uniform for all wheels.

4. Seasonal Requirements: Paving shall be divided into two seasons, In-Season and Extended Season; In-Season shall be from May 1 – September 30, and Extended Season shall be from October 1- April 30. In no case shall the final lift of HMA be placed during the extended season unless otherwise authorized or directed by the Engineer. No HMA mixes shall be placed when the air or base temperature is below 32°F. HMA for temporary pavement will be subject to the seasonal requirements unless otherwise authorized or directed by the Engineer.

Additional Requirements for Extended Season:

The minimum mixture temperature for all HMA mixtures in the delivery truck prior to discharge into the paver or transfer vehicle hopper shall be 290°F. The temperature will be taken from the initial discharge of mixture from the truck. If found to be below the minimum requirement, the truck will not be allowed to unload remaining mixture.

The Contractor shall use a minimum of 3 rollers with operators for paving lengths greater than 1000 feet. Two rollers must be capable of operating in the dynamic mode.

The Contractor's Quality Control Plan shall include a section on Extended Season Paving and address paver speed, roller patterns and balancing mixture delivery and placement operations to meet specification requirements.

5. Superpave Test Section: The Engineer may require the Contractor to place a test section whenever the requirements of this specification or M.04 are not met.

The Contractor shall submit the quantity of mixture to be placed and the location of the test section for review and acceptance by the Engineer. The equipment used in the construction of a passing test section shall be used throughout production.

If a test section fails to meet specifications, the Contractor shall stop production, make necessary adjustments to the job mix formula, plant operations, or procedures for placement and compaction. The Contractor shall construct test sections, as allowed by the Engineer, until all the required specifications are met. All test sections shall also be subject to removal as set forth in Section 1.06.04 of the Form 816.

6. Transitions for Roadway Surface: Transitions shall be formed at any point on the roadway where the pavement surface deviates, vertically, from the uniform longitudinal profile as specified on the plans. Whether formed by milling or by bituminous concrete mixture, all transition lengths shall conform to the criteria below unless otherwise specified.

Permanent Transitions: A permanent transition is defined as any transition that remains as a permanent part of the work. All permanent transitions, leading and trailing ends shall meet the following length requirements:

- a) Roadways greater than 35 MPH = 30 feet per inch of vertical change (thickness)
- b) Roadways 35 MPH or less = 15 feet per inch of vertical change (thickness).
- c) Bridge Overpass and underpass transition length will be 75 feet either
  - (1) Before and after the bridge expansion joint, or
  - (2) Before or after the parapet face of the overpass.

In areas where it is impractical to use the above described permanent transition lengths the use of a shorter permanent transition length may be permitted when approved by the Engineer.

Temporary Transitions: A temporary transition is defined as a transition that does not remain a permanent part of the work. All temporary transitions shall meet the following length requirements:

- a) Roadways greater than 35 MPH
  - (1) Leading Transitions = 15 feet per inch of vertical change (thickness)
  - (2) Trailing Transitions = 6 feet per inch of vertical change (thickness)
- b) Roadways 35 MPH or less

(1) Leading and Trailing = 4 feet per inch of vertical change (thickness)

Note: Any temporary transition to be in-place over the winter shutdown period, holidays, or during extended periods of inactivity (more than 7 calendar days) shall conform to the "Permanent Transition" requirements shown above.

7. Spreading and Finishing of Mixture: Prior to the placement of the bituminous concrete, the underlying base course shall be brought to the plan grade and cross section within the allowable tolerance. Immediately before placing the mixture, the area to be surfaced shall be cleaned by sweeping or by other means acceptable to the Engineer. The HMA mixture shall not be placed whenever the surface is wet or frozen. The temperature of the mix at time of placement must be between 265°F and 325°F. The Engineer will verify the mix temperature by means of a probe or infrared type of thermometer. Rejection of mixture based on temperature will only be allowed if verified by means of a probe type thermometer.

Placement: The HMA mixture shall be placed and compacted to provide a smooth, dense surface with a uniform texture and no segregation at the designed thickness and dimensions indicated in the plans and specifications. The maximum paver speed during placement shall not exceed 40 ft/min unless authorized by the Engineer.

When unforeseen weather conditions prevent further placement of the mix, the Engineer is not obligated to accept or place the bituminous concrete mixture that is in transit from the plant.

In advance of paving, traffic control requirements shall be set up daily, maintained throughout placement, and shall not be removed until all associated work including density testing is completed.

The Contractor shall inspect the newly placed pavement for defects in the mixture or placement before rolling is started. Any deviation from standard crown or section shall be immediately remedied by placing additional mixture or removing surplus mixture. Such defects shall be corrected to the satisfaction of the Engineer.

Where it is impractical due to physical limitations to operate the paving equipment, the Engineer may permit the use of other methods or equipment. Where hand spreading is permitted, the mixture shall be placed by means of suitable shovels and other tools, and in a uniformly loose layer at a thickness that will result in a completed pavement meeting the designed grade and elevation.

Placement Tolerances: Each lift of HMA placed at a uniform design thickness shall meet the following requirements for thickness and area. Any pavement exceeding these limits shall be subject to an HMA adjustment or removal. Lift tolerances will not relieve the Contractor from meeting the final designed grade. Lifts of designed non-uniform thickness, i.e. wedge or shim course, shall not be subject to thickness and area adjustments.

a) Thickness- Where the total thickness of the lift of mixture exceeds that shown on the plans beyond the tolerances shown in Table 2, the longitudinal limits of such variation including locations and intervals of the measurements will be documented by the Engineer for use in calculating a HMA adjustment.

TABLE 2 - Thickness Tolerances

Mixture Designation	Lift Tolerance
Class 4 and HMA S1	+/- $\frac{3}{8}$ inch
Class 1, 2 and 12 and HMA S0.25, S0.375, S0.5	+/- $\frac{1}{4}$ inch

Where the thickness of the lift of mixture is less than that shown on the plans beyond the tolerances shown in Table 2, the Contractor, with the approval of the Engineer, shall take corrective action in accordance with this specification.

- b) Area- Where the width of the lift exceeds that shown on the plans by more than the designed thickness of each lift, the longitudinal limits of such variation including locations and intervals of the measurements will be documented by the Engineer for use in calculating a HMA adjustment.
- c) Delivered Weight of Mixture - When the delivery ticket shows that the truck exceeds the allowable gross weight for the vehicle type the quantity of tons representing the over weight will be documented by the Engineer for use in calculating a HMA adjustment.

Transverse Joints: All transverse joints shall be formed by saw-cutting a sufficient distance back from the previous run, existing bituminous concrete pavement or bituminous concrete driveways to expose the full thickness of the lift. A brush of tack coat shall be used on any cold joint immediately prior to additional bituminous concrete mixture being placed.

Tack Coat Application: A thin uniform coating of tack coat shall be applied to the pavement immediately before overlaying and be allowed sufficient time to break (set). All surfaces in contact with the HMA that have been in place longer than 3 calendar days shall have an application of tack coat. The tack coat shall be applied by a non-gravity pressurized spray system that results in uniform overlapping coverage at a target application rate of 0.07 + 0.02 gallons per square yard for a non-milled surface and a target application rate of 0.12 + 0.02 gallons per square yard for a milled surface. For areas where both milled and un-milled surfaces occur, the tack coat shall be a target application rate of 0.07 + 0.02 gallons per square yard. The Engineer must approve the equipment and the method of measurement prior to use. The material for tack coat shall not be heated in excess of 160°F and shall not be further diluted.

Compaction: The Contractor shall compact the mixture to meet the density requirements as stated in Section 4.06.03-11 and eliminate all roller marks without displacement, shoving, cracking, or aggregate breakage.

The Contractor shall only operate rollers in the dynamic mode using the oscillatory system at the lowest frequency setting on concrete structures such as bridges and catch basins. The use of the vibratory system on concrete structures is prohibited.

Rollers operating in the dynamic mode shall be shut off when reversing directions.

If the Engineer determines that the use of compaction equipment in the dynamic vibratory mode may damage highway components, utilities, or adjacent property, the Contractor shall provide alternate compaction equipment. The Engineer may allow the Contractor to operate rollers in the dynamic mode using the oscillatory system at the lowest frequency setting.

These allowances will not relieve the Contractor from meeting pavement compaction requirements.

Surface Requirements: The pavement surface of any lift shall meet the following requirements for smoothness and uniformity. Any irregularity of the surface exceeding these requirements shall be corrected by the Contractor.

- a) Smoothness- Each lift of the surface course shall not vary more than ¼ inch from a Contractor-supplied 10 foot straightedge. For all other lifts of HMA, the tolerance shall be 3/8 inch. Such tolerance will apply to all paved areas.

b) Uniformity- The paved surface shall not exhibit segregation, rutting, cracking, disintegration, flushing or vary in composition as determined by the Engineer.

8. HMA Longitudinal Joint Construction Methods: Unless noted on the plans or the contract documents or directed by the Engineer, the Contractor shall use Method I- Notched Wedge when constructing longitudinal joints where lift thicknesses are between 1½ and 3 inches. Method II shall be used for lifts less than 1½ inches or greater than 3 inches. During placement of multiple lifts of HMA, the longitudinal joint shall be constructed in such a manner that it is located at least 6 inches from the joint in the lift immediately below. The joint in the final lift shall be at the centerline or at lane lines.

Method I - Notched Wedge Joint:

A notched wedge joint shall be constructed, as shown in the figure using a device attached to the paver screed that is capable of producing a uniform slope.

The taper portion of the joint must be placed over the longitudinal joint in the lift immediately below. The top vertical notch must be located at the centerline or lane line in the final lift. The requirement for paving full width "curb to curb" as described in Method II will be waived in those areas where the notched wedge joint is utilized.

The taper portion of the wedge joint shall be compacted and not be exposed to traffic for more than 5 calendar days.

The existing pavement surface under the wedge joint must have an application of tack coat material. Prior to placing completing pass (hot side), an application of tack coat must be applied to the tapered section.

Any exposed wedge joint must be located to allow for the free draining of water from the road surface.

The Engineer reserves the right to define the paving limits when using a wedge joint that will be exposed to traffic.

Method II - Butt Joint:

When adjoining HMA passes are placed, the Contractor shall utilize equipment that creates a near vertical edge (refer to figure). The completing pass (hot side) shall have sufficient mixture so that the compacted thickness is not less than the previous pass (cold side). The end gate on the paver should be set so there is an overlap onto the cold side of the joint.

The Contractor shall not allow any butt joint to be incomplete at the end of a work shift unless otherwise allowed by the Engineer. When using this method, the Contractor is not allowed to leave a vertical edge exposed at the end of a work shift and must complete paving of the roadway full width "curb to curb."

Method III- Butt Joint with Hot Poured Rubberized Asphalt Treatment: When required by the contract or allowed by the Engineer, Method III may be used.

All of the requirements of Method II must be met with Method III. In addition, the longitudinal vertical edge must be treated with a hot poured rubberized asphalt material prior to placing a completing pass. The rubberized asphalt material shall be applied in accordance with the manufacturer's recommendation so as to provide a uniform coverage and avoid excess bleeding onto the newly placed pavement.

9. Contractor Quality Control (QC) Requirements for HMA Placement: A Quality Control Plan (QCP) shall be required for any project that has a total of 2500 tons or more of HMA.

Quality Control is defined as all those planned and specified actions or operations necessary to produce bituminous concrete that will meet contract specification requirements. The Contractor shall be responsible for quality control throughout the production and placement operations. Therefore, the Contractor must ensure that the materials, mixture and work provided by Subcontractors, Suppliers and Producers also meet contract specification requirements.

Quality Control Plan: Prior to placement and production, the Contractor shall submit a QCP to the Engineer for approval. The QCP shall include separate sections for HMA Plant Production and for HMA Placement which shall describe the organization and procedures which the Contractor shall use to administer quality control. The QCP shall include the procedures used to control the HMA production and placement process, to determine when immediate changes to the processes are needed, and to implement the required changes. The QCP must address the actions, inspection, sampling and testing necessary to keep the production and placement operations in control, to determine when an operation has gone out of control and to respond to correct the situation and bring it back into control.

The QCP shall also include the name and qualifications of a Quality Control Manager. The Quality Control Manager shall be responsible for the administration of the QCP, including compliance with the plan and any plan modifications. The Quality Control Manager shall be directly responsible to the Contractor and shall have the authority to make decisions where the quality of the work or product is concerned. All sampling, inspection and test reports shall be reviewed and signed by the Quality Control Manager prior to submittal to the Engineer.

Approval of the QCP will be based on the inclusion of all of the required information. Approval of the QCP does not imply any warranty by the Engineer that adherence to the plan will result in production of HMA that complies with these specifications. It shall remain the responsibility of the Contractor to demonstrate such compliance. The Contractor may propose in writing a supplement to the QCP as work progresses and must propose a supplement whenever there are changes in production or placement of HMA or to quality control procedures or personnel. HMA production and placement may be suspended by the Engineer until the revisions to the QCP have been put into effect.

The Quality Control Plan shall also include the name and qualifications of any outside testing laboratory performing any QC functions on behalf of the Contractor.

Quality Control Inspection, Sampling and Testing: The Contractor shall perform all quality control sampling and testing, provide inspection, and exercise management control to ensure that HMA production and placement conforms to the requirements as outlined in its QCP during all phases of the work.

a) Control Charts: The Contractor shall develop and maintain control charts and shall be distributed as directed by the Engineer. The control charts shall identify the project, test number, test parameter, applicable upper and lower specification limits, and test data. The control charts shall be used as part of the quality control system to document variability of the HMA production and placement process. The control charts shall be kept current. The control charts shall be updated each day of HMA production, and up-to-date copies shall be distributed prior to the beginning of the next day's production of HMA.

b) Records of Inspection and Testing: For each day of HMA production and placement, the Contractor shall document all test results and inspections on forms approved by the Engineer. The document shall be certified by the Quality Control Manager or his representative that the information in the document is accurate, and that all work complies with the requirements of the contract.

The Contractor shall submit sampling, testing and inspection documents to the Engineer within 24 hours or by noon of the next day's HMA production. If the document is incomplete or in error, a copy of the document will be returned to the Contractor with the deficiencies noted by the Engineer. The Contractor shall correct

the deficiencies and return the updated document to the Engineer by the start of the following working day. When errors or omissions in the sampling, inspection or testing documents repeatedly occur, the Contractor shall correct the procedures by which the documents are produced.

If control charts, sampling, testing and inspection documents are not distributed or provided as required within the time specified the Engineer may require work to be suspended until the missing documents have been provided.

Additional requirements for HMA plant production are defined in Section M.04 of the Form 816, as amended.

10. Core Correlation Procedure for Density Testing of HMA: Core correlation is required for all limited access highways and any other roadways in which 10,000 tons or more HMA mixture is placed.

This procedure describes the frequency and the method the Contractor shall use to obtain pavement cores from the project. Coring shall be performed the first time a HMA lift requiring density testing is placed. Prior to receiving core results, the HMA density acceptance will be determined using a nuclear density gauge correlated to the standard block located at the Department's Material Testing Laboratory. The gauge will be correlated to the core results once they are known.

The Contractor shall provide a minimum of one set of cores (5 cores per set) for each lift that will be tested for density. The Contractor may be required to provide additional sets of cores under the following conditions:

- a) A change in source of component aggregates.
- b) Any change in the average Gmm greater than 0.030 as indicated in the plant test results representing cored mixture.
- c) Change in materials supplied in Section 4.06.02-1.

The Contractor shall extract 5 cores (6 inch diameter-wet sawed) from sampling locations determined by the Engineer. The Engineer will witness the extraction and labeling of cores. The cores shall be labeled by the Contractor with number, location, date and delivered in a safe manner to ensure no damage occurs (i.e., core 1M for first mat core; core 1J for first joint core, etc) to Department personnel as directed by the Engineer. The cores will be tested by the Engineer in accordance with AASHTO T 331(M).

Any cores that are damaged or obviously defective while being obtained will be replaced with new cores from a location within a 2 foot radius.

Core holes shall be filled immediately upon core extraction by removing any free water, applying tack coat to the cut surface, filling with same HMA mixture, and compacting with hand compactor or other mechanical means to the maximum compaction possible. The field mixture shall be compacted to 1/8 inch above the finished pavement prior to opening the roadway to traffic.

11. Acceptance Inspection, Sampling and Testing: Inspection, sampling, and testing to be used by the Engineer shall be performed at the minimum frequency specified in Section M.04 and stated herein.

Sampling for acceptance shall be established using a statistically based procedure of random sampling approved by the Engineer.

HMA Plant Material Acceptance: The Contractor shall provide the required acceptance sampling, testing and inspection during all phases of the work in accordance with Section M.04.

HMA Density Acceptance: All acceptance testing will be performed by the Engineer for the completed pavement course on roadways and bridges in accordance with the Department's density testing procedures.



Each lift designed to a compacted lift of 1½ inches or more shall have the HMA pavement including the longitudinal joints compacted to 94.5 +/- 2.5 percent of the maximum theoretical gravity. Bituminous Concrete Class 4 and HMA S1 are excluded from the longitudinal joint density requirements.

12. Density Dispute Resolution Process: The Contractor and Engineer will work in partnership to avoid potential conflicts and to resolve any differences that may arise during quality control or acceptance testing for density. Both parties will review their sampling and testing procedures and results and share their findings. If the Contractor disputes the Engineer's test results, the Contractor must submit in writing a request to initiate the Dispute Resolution Process within 10 calendar days of the placement of the mixture. No request for dispute resolution will be allowed unless the Contractor provides quality control results supporting its position. Should the dispute not be resolved through evaluation of existing testing data or procedures, the Engineer may authorize the Contractor to obtain representative core samples of the pavement. The core samples must be extracted no later than 30 calendar days from the date of Engineer's authorization. Core samples shall be located using the stratified random sampling procedure in accordance with ASTM D 3665 as determined by the Engineer. Core samples shall be extracted and filled using the procedure outlined in the Core Correlation Procedure. The densities from the 5 representative cores will be averaged for determining the final HMA density acceptance including any payment adjustments, in accordance with Section 112.4-2 that may apply.

13. Corrective Work Procedures: Any portion of the completed pavement that does not meet the requirements of the specification shall be corrected at the expense of the Contractor. Any corrective courses placed as the final wearing surface shall not be less than 1½ inches in thickness after compaction.

If pavement placed by the Contractor does not meet the specifications, and the Engineer requires its replacement or correction, the Contractor shall:

- a) Propose a corrective procedure to the Engineer for review and approval prior to any corrective work commencing. The proposal shall include:
  - Limits of pavement to be replaced or corrected, indicating stationing or other landmarks that are readily distinguishable.
  - Proposed work schedule.
  - Construction method and sequence of operations.
  - Methods of maintenance and protection of traffic.
  - Material sources.
  - Names and telephone numbers of supervising personnel.
- b) Perform all corrective work in accordance with the Contract and the approved corrective procedure.

14. Protection of the Work: The Contractor shall protect all sections of the newly finished pavement from damage that may occur as a result of the Contractor's operations for the duration of the Project. Prior to the Engineer's authorization to open the pavement to traffic, the Contractor is responsible to protect the pavement from damage.

15. Joints and Cracks in Bituminous Concrete Pavement: Work under this section shall consist of constructing new joints or repairing existing joints and cracks.

Equipment: All equipment necessary for the work shall meet the following requirements:

- a) Kettle: The unit shall be a combination melter and pressurized applicator of a double-boiler type with space between the inner and outer shells filled with oil or other material not having a flash point of less than 600°F. The kettle shall include a temperature control indicator and mechanical agitator. The kettle shall be capable of maintaining the material at a temperature within 15°F of the manufacturer's recommended temperature.

b) Compressor: The compressor shall have a sufficient capacity and length of hose to enable a continuous sealing operation.

c) Saw: The saw shall be capable of providing a straight cut of uniform depth and width.

Joint Seal Material: Material that is heated or cooled beyond the manufacturer's recommended temperature range shall be discarded.

Sawing and Sealing Joints in Bituminous Concrete Pavement: Work under this item shall consist of making a straight-line saw cut transversely across the final lift of HMA pavement directly over the new and existing Portland Cement concrete (PCC) transverse joints. The sawing and sealing of joints shall be completed for HMA pavements with a total depth of 3 inches or greater. The saw cut shall be immediately cleaned and sealed with a joint seal material. The sawing and sealing shall commence within one week of the completion of the final lift of pavement and be a continuous operation until all joints have been completed.

Prior to the paving operation, the Contractor shall establish sufficient controls to locate each transverse joint. This work shall include setting markers at each joint to reference its location and alignment, and having each of these markers tied and referenced. A written procedure for this work shall be submitted to the Engineer for review prior to commencement of such work.

The saw cut will be made by using diamond saw blades with a gang blade arrangement in order to achieve the joint detail as shown on the plans. The saw cut will be in a straight line across the pavement directly over the joint. Transverse joints shall extend to a point 2 feet beyond the underlying PCC pavement. The sawed joints shall be cleaned with compressed air to the satisfaction of the Engineer.

Immediately following the cleaning, the joint seal material shall be installed. When cooled, the top of the sealant material shall be recessed a minimum of 1/16 inch but not greater than 1/8 inch below the adjacent pavement surface. The roadway shall not be opened to traffic until the material has become tack free. Any depression in the sealer greater than 1/8 inch shall be brought up to the specified limit by further addition of joint seal material. Care shall be taken during the sealing operation to ensure that overfilling and spilling of material is avoided.

Any reflective cracking attributable to improper joint referencing or construction shall be repaired at the expense of the Contractor, in a manner approved by the Engineer for a period of one year from the date of completion of any sawed and sealed portion of final pavement.

Cleaning and Sealing Joints and Cracks in Pavement: Work under this item shall consist of cleaning existing joints and cracks of all dirt, dust, loose joint material, and all deleterious matter with compressed air as directed by and to the satisfaction of the Engineer. After a sufficient number of joints and cracks have been cleaned so as to ensure a continuous operation, all joints and cracks shall be sealed with joint seal material.

Cutting and Sealing Joints in the Bituminous Concrete Shoulder: When PCC pavement is the final wearing surface a longitudinal saw cut at the interface of the bituminous concrete shoulder and PCC pavement shall be made. The saw cut shall be made in the bituminous concrete shoulder to expose the abutting edge of the PCC pavement. The size of the saw cut shall be 1/2 inch wide by 1 1/2 inches deep.

Kerf Cut in Bituminous Concrete Pavement: If the final lift of pavement will not be completed prior to winter shutdown, each exposed course shall have a 1/4 inch by 1/4 inch kerf cut above the new and existing transverse joints. The kerf shall be cut with a saw or abrasive wheel approved by the Engineer. The kerf cut shall not be sealed.

16. Cut Bituminous Concrete Pavement: Work under this item shall consist of making a straight-line cut in the bituminous concrete pavement to the lines delineated on the plans or as directed by the Engineer. The cut shall provide a straight, clean, vertical face with no cracking, tearing or breakage along the cut edge.

Method of Measurement:

1. Bituminous Concrete Class ( ) or HMA S\* : The quantity of bituminous concrete measured for payment will be determined by the documented net weight in tons accepted by the Engineer in accordance with this specification and Section M.04 of the Form 816, as amended.

2. HMA Adjustments: Adjustments may be applied to bituminous concrete quantities and will be measured for payment using the following formulas:

Yield Factor for Adjustment Calculation = 0.0575 Tons/SY/inch

Actual Area = [(Measured Length (ft)) x (Avg. of width measurements (ft))]

Actual Thickness (t) = Total tons delivered / [Actual Area (SY) x 0.0575 Tons/SY/inch]

a) Area: If the average width exceeds the allowable tolerance, an adjustment will be made using the following formula. The tolerance for width is equal to the designed thickness (in.) of the lift being placed.

Tons Adjusted for Area (TA) = [(L x Wadj)/9] x (t) x 0.0575 Tons/SY/inch = (-) Tons

Where: L = Length (ft)

(t) = Actual thickness (inches)

Wadj = (Designed width (ft) + tolerance /12) - Measured Width)

b) Thickness: If the actual thickness is less than the allowable tolerance, the Contractor shall submit a repair procedure to the Engineer for approval. If the actual thickness exceeds the allowable tolerance, an adjustment will be made using the following formula:

Tons Adjusted for Thickness (TT) = A x tadj x 0.0575 = (-) Tons

Where: A = Area = {[L x (Designed width + tolerance (lift thickness)/12)] / 9}

tadj = Adjusted thickness = [(Dt + tolerance) - Actual thickness]

Dt = Designed thickness (inches)

c) Weight: If the quantity of bituminous concrete representing the mixture delivered to the project is in excess of the allowable gross vehicle weight (GVW) for each vehicle, an adjustment will be made using the following formula:

Tons Adjusted for Weight (TW) = GVW – DGW= (-) Tons

Where: DGW = Delivered gross weight as shown on the delivery ticket or measured on a certified scale.

d) Mixture Adjustment: If the quantity of bituminous concrete representing the produced mixture exceeds one or more of the production tolerances for Marshall (Table 3) or Superpave mix designs (Table 3A & 3B) , an adjustment will be made using the following formulas. The Department's Division of Material Testing will calculate the daily adjustment values for TMD and TSD.

(1) Marshall Design- The tolerances shown in Table 3 for gradation and binder content will be used to determine whether a mixture adjustment will apply. If the mixture does not meet the requirements of Section M.04 of the Form 816, an adjustment will be computed using the following formula:

Tons Adjusted for Marshall Design (TMD) = M x 0.10

Where: M= Tons of bituminous concrete mixture exceeding tolerances in Table 3

TABLE 3  
TOLERANCES FOR CONSECUTIVE TESTS (MARSHALL)

Classes	Criteria	% Tolerances (+/-)
-	Binder	0.4
1, 2, 4, 5, 5A & 5B	#200	2.0
1, 2, 4	#50	4
1, 2, 5, 5A & 5B	#30	5
1, 2, 4, 5, 5A & 5B	#8	6
1, 2, 4, 5, 5A & 5B	#4	7
1, 2, 4, 5, 5A & 5B	<sup>3</sup> / <sub>8</sub> & <sup>1</sup> / <sub>2</sub> inch	8

(2) Superpave Design- The adjustment values in Table 3A & 3B shall be calculated for each sub lot based on the Air Void and Liquid Binder Content test results for that sub lot. The total adjustment for each day's production (lot) will be computed using tables and the following formulas:

Tons Adjusted for Superpave Design (TSD) = (AVa + APb) x Tons

Adjustment for Air Void = AVa = [(Va1 + Va2 + Vai + ... + Van)] / n

Where: Va = Total air void adjustment value for the lot  
Vai = Adjustment value from Table 3A resulting from each sub lot  
n = number of air void tests in a production lot

TABLE 3A  
ADJUSTMENT VALUES FOR AIR VOIDS (SUPERPAVE)

Adjustment Value (AVa) (%)	HMA S0.25, S0.375, S0.5, S1 Air Voids (Va)
+2.5	3.5 - 4.5
0.0	3.0 - 3.4 or 4.6 - 5.0
- 5.0	2.7 - 2.9 or 5.1 - 5.3
- 10.0	2.3 - 2.6 or 5.4 - 5.7
-20.0	≤ 2.2 or ≥ 5.8

Adjustment for Liquid Binder = APb = [(APb1 + APb2 + APbi + ... + APbn)] / n

Where: APb = Total liquid binder adjustment value for the lot  
APbi = Adjustment value from Table 3B resulting from each sub lot  
n = number of binder tests in a production lot

TABLE 3B  
ADJUSTMENT VALUES FOR LIQUID BINDER (SUPERPAVE)

Adjustment Value(APb) (%)	HMA S0.25, S0.375, S0.5, S1 Pb (refer to Table M.04.03-5)
0.0	Equal to or above the min. liquid content

- 10.0	Below the min. liquid content
--------	-------------------------------

e) Density Adjustment: The quantity of bituminous concrete measured for payment for a designed compacted lift of pavement 1½ inches or greater may be adjusted for density. Separate density adjustments will be made for each lot and will not be combined to establish one density adjustment.

$$\text{Tons Adjusted for Density (TD)} = \{[\text{PAM} \times .40] + [\text{PAJ} \times .60]\} \times \text{Tons accepted}$$

Where:

TD = Total tons adjusted for density for each lot

PAM = Mat density percent adjustment from Table 4

PAJ = Joint density percent adjustment from Table 4

TABLE 4  
Adjustment values for pavement density

Average % Density	% Adjustment for non-bridge lots	% Adjustment for bridge lots
97.1 – 100	-2.5	- 2.5
94.5 – 97.0	+2.5	+2.5
92.0 – 94.4	0.0	0.0
91.0 – 91.9	-2.5	- 10.0
89.1 – 90.9	-15.0	- 30.0
87.0 – 89.0	-30.0	- 50 or Remove and Replace
86.9 or less	Remove and Replace	Remove and Replace

3. Transitions for Roadway Surface: The installation of permanent transitions shall be measured under the appropriate item used in the formation of the transition.

- The quantity used for the installation of temporary transitions shall be measured for payment under the appropriate HMA item used in the formation of the transition. The installation and removal of a bond breaker, and the removal and disposal of any temporary transition formed by milling or with bituminous concrete pavement is not measured for payment.

4. Cut Bituminous Concrete Pavement: The quantity of bituminous concrete pavement cut will be measured in accordance with Article 2.02.04 of the Form 816.

5. Sawing and Sealing Joints: The quantity of sawed and sealed joints measured for payment will be the actual number of linear feet of joints sawed and sealed in the bituminous concrete pavement surface approved by the Engineer.

6. Kerf Cut in Bituminous Concrete Pavement: The quantity of kerf cuts measured for payment will be the actual number of linear feet of kerf cuts in the bituminous concrete pavement surface approved by the Engineer.

7. Cleaning and Sealing Joints and Cracks: The quantity of cleaned and sealed joints and cracks measured for payment will be the actual number of pounds of joint seal material accepted by the Engineer. Weights as marked on the shipping containers shall be used; or if directed by the Engineer, scales shall be furnished by and at the expense of the Contractor, and the joint seal material weighed in a manner satisfactory to the Engineer.

8. Material for Tack Coat: The quantity of tack coat will be measured for payment by the number of gallons furnished and applied on the Project and approved by the Engineer.

a. Container Method- Material furnished in a container will be measured to the nearest ½ gallon. The volume will be determined by either measuring the volume in the original container by a method approved by the Engineer or using a separate graduated container capable of measuring the volume to the nearest ½ gallon. The container in which the material is furnished must include the description of material, including lot number or batch number and manufacturer or product source.

b. Truck Method- The Engineer will establish a weight per gallon of the bituminous material based on the specific gravity at 60°F for the material furnished. The number of gallons furnished will be determined by weighing the material on scales furnished by and at the expense of the Contractor.

Basis of Payment:

1. Bituminous Concrete Class ( ), HMA S\*: The furnishing and placing of bituminous concrete will be paid for at the Contract unit price per ton for "Bituminous Concrete, Class ( )" or "HMA S\* ( )."

All costs associated with providing illumination of the work area are included in the general cost of the work. All costs associated with constructing the notched wedge joint are included in the general cost of the work. All costs associated with obtaining cores for core correlation and dispute resolution are included in the general cost of the work.

2. HMA Adjustment Cost: The "HMA Adjustment Cost" will be calculated using the formula shown below if all of the measured adjustments in Section 112.4 do not equal a value of zero. A payment will be made for an increase in costs. A deduction from monies due the Contractor will be made for a decrease in costs.

Formula:  $[TT + TA + TW + (TMD \text{ or } TSD) + TD] \times \text{Unit Price} = \text{Est.}$

Where: Unit Price = Contract unit price per ton per type of mixture

TT = Total tons of each adjustment calculated in Section 112.4

Est. = Pay Unit represented in dollars representing HMA incentive or disincentive.

The estimated cost figure if included in the bid proposal or estimate is not to be altered in any manner by the bidder. If the bidder should alter the amount shown, the altered figure will be disregarded and the original cost figure will be used to determine the amount of the bid for the Contract.

3. Transitions for Roadway Surface: The installation of permanent transitions shall be paid under the appropriate item used in the formation of the transition. The quantity used for the installation of temporary transitions shall be paid under the appropriate HMA item used in the formation of the transition. The installation and removal of a bond breaker, and the removal and disposal of any temporary transition formed by milling or with bituminous concrete pavement is included in the general cost of the work.

4. The cutting of bituminous concrete pavement will be paid in accordance with Article 2.02.05 of the Form 816.

5. The sawing and sealing of joints will be paid for at the Contract unit price per linear foot for "Sawing and Sealing Joints".

6. Kerf cuts will be paid for at the Contract unit price per linear foot for "Kerf Cut in Bituminous Concrete Pavement".

7. The cleaning and sealing of joints and cracks will be paid for at the Contract unit price per pound for "Cleaning and Sealing Joints and Cracks".
8. Material for tack coat will be paid for at the Contract unit price per gallon for "Material for Tack Coat".

**ITEM # 0507001A                      TYPE "C" CATCH BASIN**

**ITEM # 0507003A                      REMOVE EXISTING CATCH BASIN**

**ITEM # 0507821A                      CONVERT CATCH BASIN TO TYPE "C-L" CATCH BASIN**

**ITEM # 0507831A                      CONVERT CATCH BASIN TO MANHOLE**

These items shall conform to Section 5.07 CATCH BASINS, MANHOLES, AND DROP INLETS of the Form 816, modified as follows:

Construction Methods: Trench excavation, dewatering, and backfill for these items shall be according to the special provisions for EARTH TRENCH EXCAVATION and TRENCH DEWATERING, included elsewhere in these specifications.

Manholes shall not be included under this item, but shall conform to the special provisions for MANHOLES and RESET MANHOLE provided elsewhere in these specifications.

Method of Measurement: There will be no measurement for trench excavation in the installation or removal of the various drainage appurtenances.

Basis of Payment: The work under these items shall be paid for at the unit contract price each for type of catch basins and drop inlets complete in place and shall include all materials, tools, equipment, and labor necessary to complete the excavation and installation of units in conformity with the plans, or as specified.

The work associated with removal and disposal of existing catch basins shall be measured and paid for each catch basin removed under the item "Remove Existing Catch Basin" as listed in the bid proposal. The payment for removal and disposal of existing catch basin shall include all materials, tools, equipment, and labor necessary to complete the excavation and removal of these units in conformity with the plans, or as specified.



**ITEM # 0507006A                      REPLACE CATCH BASIN TOP**

These items shall conform to Section 5.07 CATCH BASINS, MANHOLES, AND DROP INLETS of the Form 816, modified as follows:

Construction Methods: Trench excavation, dewatering, and backfill for these items shall be according to the special provisions for EARTH TRENCH EXCAVATION and TRENCH DEWATERING, included elsewhere in these specifications.

Method of Measurement: Replacement of catch basin tops will be paid for as a unit, which shall include all work related to resetting the basin top as required as well as the cost for the new catch basin top. When replacing catch basin tops, there will be no measurement for any work related to resetting the top, including excavation; cutting, removal and replacement of pavement; or pervious material and backfill.

Basis of Payment: This work shall be paid for at the contract unit price for "Replace Catch Basin Top" as listed in the bid proposal for each catch basin top replaced complete in place, regardless of type, and shall include all materials, tools, equipment, and labor necessary to complete installation and resetting of the top as required including excavation, removal and replacement of paving, cutting, and pervious backfill in conformity with the plans and as specified.

**ITEM # 0507781A                      RESET MANHOLE TOP**

General: Under this item shall be included the alteration or reconstruction of existing manholes in conformity with the lines, grades, dimensions, and details shown on the plans, or as ordered, and in accordance with the provisions of these specifications for the various materials and work which constitute the completed structure.

Construction Methods: Frames, covers and tops which are to be reset shall be removed from their present beds, the walls or sides shall be rebuilt to conform to the requirements of the new construction and the tops, frames and covers reset, or the grates or covers may be raised by extensions of suitable height approved by the Engineer.

Method of Measurement: Resetting tops, frames and covers will be measured as units. When resetting tops, frames and covers, there will be no measurement for excavation; cutting, removal and replacement of pavement; pervious material and backfill.

Payment: Reset Units will be paid for at the contract unit price each for "Reset Manhole," of the type specified, respectively, complete in place, which price shall include excavation, pervious material, backfill, cutting of pavement, removal and replacement of pavement structure, extensions, concrete masonry units, mortar, and all materials, equipment, tools and labor incidental thereto.

**ITEM # 0651012A                      15" R.C. PIPE**

This item shall conform to Section 6.51 CULVERTS of the Form 816, modified as follows:

Construction Methods: Trench excavation, dewatering, and backfill for these items shall be according to the special provisions for EARTH TRENCH EXCAVATION and TRENCH DEWATERING, included elsewhere in these specifications.

Method of Measurement: There will be no direct measurement for trench excavation and there will be no measurement for payment for gravel fill, bedding material, or for the cost of connecting proposed drainage systems with existing systems, but the cost thereof shall be included in the contract unit price per linear foot for the size and type of pipe being installed.

Basis for Payment: The work under these items will be paid for at the contract unit price per linear foot of pipe and size specified, complete in place including trench excavation, gravel fill, bedding material and all other materials, equipment, tools, and labor incidental thereto.

**ITEM # 0921001A                      CONCRETE SIDEWALKS**

**ITEM # 0921002A                      CONCRETE SIDEWALKS – 8” THICK**

**ITEM # 0921005A                      CONCRETE SIDEWALK RAMPS**

General: The Contractor is to construct sidewalks to lines and grades as shown on the drawings or at locations as directed by the Engineer. The sidewalks shall be of monolithic construction and five inches thick, except at industrial and commercial driveways where it shall be eight inches thick and reinforced with 6” x 6” 10/10 steel mesh. Sidewalk construction shall include the removal of existing and construction of new house lateral walks where new sidewalk grades make it necessary. At street corners where the intersection is rounded with a radius of less than 25 feet to the curb, the sidewalk slabs will be a minimum of five feet in length and constructed of five-inch thick concrete. The sidewalk shall pitch to the street at a slope of ¼-inch per foot or as directed by the Engineer.

Concrete sidewalk ramps are to be constructed to the lines and grades shown on the plans at locations directed by the Engineer, and shall be a minimum of five inches thick. This work shall also include furnishing and installing Detectable Warning Strips in the locations and to the dimensions and details shown on the plans or as ordered by the Engineer.

Materials:

Base Course: The material used for base course construction shall conform to the requirements of Section M.02.01 of the Form 816 for broken or crushed stone. It shall consist of sound, tough, and durable stone and shall be free of thin or elongated pieces, lumps of clay, soil, loam, or vegetative matter. All material shall be approved by the Engineer prior to its use.

Forms: The forms used shall be five-inch steel or 2” x 6” wood firmly supported and staked to the line and grade given by the Engineer. The forms shall be free from warp and shall be of sufficient strength to resist springing out of shape. All forms shall be cleaned and oiled before use.

Concrete: The concrete furnished shall conform with respect to composition, transportation, mixing and placing, to Class F Cement Concrete 4,000 PSI, as specified by the State of Connecticut Department of Transportation in its latest specification and revisions. An approved air-entraining admixture shall be used to entrain 5% to 7% air in the concrete.

Detectable Warning Strips: The Detectable Warning Strip shall be a prefabricated detectable warning surface tile as manufactured from Engineered Plastics Inc. 300 International Drive, Suite 100 Williamsville, NY 14221, telephone number (800) 682-2525 or the approved equal from ADA Fabricators, INC. P.O. Box 179 North Billerica, MA 01862 telephone number (978) 262-9900. The tile shall conform to the dimensions shown on the plans and have a brick red homogeneous color throughout in compliance with Federal Standard 595A Color #22144 or approved equal.

The Detectable Warning Strip shall be set directly in poured concrete according to the plans and the manufacturer’s specifications or as directed by the Engineer. The Contractor shall place two 11.34 Kg concrete blocks or sandbags on each tile to prevent the tile from floating after installation in wet concrete.

Dowels: Smooth metal dowels, 5/8-inch in diameter, measuring 24 inches in length shall be installed using plastic sleeves within all expansion and contraction joints, concrete driveway aprons, at concrete sidewalk ramps, and at the last end section of each sidewalk slab poured at the end of each working day.

Plastic sleeves of the size required for accepting the 5/8-inch by 24-inch smooth metal dowels shall be "Speed Dowel" sleeves as manufactured by Greenstreak, 3400 Tree Court Industrial Blvd, St. Louis, MO 63122, telephone number (800) 551-5145 or approved equal. Plastic sleeves shall be installed according to manufacturer instructions and as directed by the Engineer.

Dowels are also to be installed between new and existing concrete slabs. Where new or repaired walks abut up against existing concrete sidewalks, the Contractor shall drill two holes measuring  $\frac{3}{4}$ -inches in diameter and 12 inches in depth into the existing concrete slab. The dowels, with plastic sleeve, shall be set into the existing sidewalk slab prior to the placement of concrete. The dowels are to be level with the latitude pitch of the sidewalk and shall conform to details of these specifications.

Smooth metal dowels shall be 5/8-inch in diameter and 24 inches in length. All metal dowels shall conform to the requirements of ASTM A615 Grade 60.

Expansion Joints: At maximum intervals of 15 feet, an expansion joint shall be placed to the full depth of the concrete slab. The material for expansion joints shall be either  $\frac{1}{4}$ -inch thick cork asphalt or  $\frac{3}{8}$ -inch thick asphalt impregnated bonded cellular fiber, or approved equal. Expansion joints of the same material shall also be placed at points abutting existing structures.

Construction Methods:

Limits of Disturbance: The Contractor is to exercise caution to prevent unnecessary damage to lawns, trees, bushes, or any other existing improvements. If, in the opinion of the Engineer, existing improvements are damaged due to the carelessness of the Contractor, the same shall be repaired or replaced at the Contractor's expense.

Earthwork: The Contractor shall remove and dispose of grass, rubbish, and other objectionable materials within the limits of the sidewalk construction. The Contractor shall perform all excavation necessary to construct sidewalks to the grades as shown on the construction plans. Excavation shall include the saw cutting, removal, and disposal of bituminous concrete and concrete sidewalks, driveways, and pavements, including curbing and tree roots, where necessary, due to the new sidewalk grade and as shown on the plans or as directed by the Engineer. Existing house lateral walks and driveways adjacent to the sidewalk shall be removed and base graded and prepared for a smooth connection. The Contractor shall remove and dispose of all excess material.

Base Course Installation: The material for the base course shall be spread upon the prepared subgrade to such depth as to give a compacted thickness of eight inches. The material shall be uniformly spread in two layers of equal depth in the entire base course excavation and each layer shall be wetted and compacted to a firm even surface with a roller weighing not less than 500 pounds or by use of pneumatic tampers or vibratory compactors.

Concrete Work: The surface finish shall be struck off, forcing coarse aggregate below mortar surface. After strike-off, the surface shall be worked and floated with a wooded, aluminum, or magnesium float followed by steel troweling. The slab shall then be broomed cross-wise with a fine hair broom. The outside edges of the slab shall be edged with a  $\frac{1}{4}$ -inch radius tool. All edging lines shall be removed.

The Contractor shall use a liquid membrane-forming curing compound. The curing compound shall be similar or equal to Demicon "Cure Hard" with fugitive dye and shall meet the latest ASTM Specification C-156. Waterproof paper or plastic membrane are acceptable alternatives.

Newly constructed sidewalk surfaces shall be protected from all foot or vehicular traffic for a period of seven days. The Contractor shall have on the job, at all times, sufficient polyethylene film or waterproof paper to provide complete coverage in the event of rain.

Temperature: No concrete is to be placed when air temperature is below 40°F, or at 45°F and falling, unless prior approval is given by the Engineer. In the event weather conditions may be such that concrete that is not completely cured is subject to freezing, the Contractor shall provide a minimum of a six-inch layer of hay, straw, or thermal blankets for protection. Any concrete laid during cold weather that is damaged by freezing shall be the responsibility of the Contractor and shall be replaced at his expense.

Final Grading: Upon completion of sidewalk construction, the Contractor is to re-grade the areas between sidewalks and curbs, if the typical section indicates a grass plot, and disturbed areas back of the sidewalk. The Contractor shall backfill and compact these areas so as to conform to the typical cross-section. The upper four inches of the backfill shall be loam or topsoil, loose and friable and free of sticks, rocks, roots, weeds, or other unsuitable material.

Basis of Payment: Concrete Sidewalk shall be measured and paid for at the Contract unit price per square foot as contained in the Bid Proposal, which price shall include the base course underneath sidewalks, excavation, grading, and all other materials and all labor, tools, and equipment necessary for completion of the work.

Concrete Sidewalk—8" Thick shall be measured and paid for at the Contract unit price per square foot as contained in the Bid Proposal, which price shall include the base course underneath sidewalks, excavation, grading, and all other materials and all labor, tools, and equipment necessary for completion of the work.

Concrete Sidewalk Ramps shall be measured and paid for as a unit at the Contract unit price for each ramp as contained in the Bid Proposal, which price shall include the base course underneath sidewalks, excavation, grading, detectable warning tile, and all other materials and all labor, tools, and equipment necessary for completion of the work.

Sawcutting of concrete sidewalk slabs will not be measured for payment. Removal, and disposal of existing concrete sidewalk sections shall be paid for at the contract unit price per square yard for "Removal of Concrete Sidewalk", which price shall include all labor, material, tools, and equipment incidental thereto.

**ITEM # 0922001A BITUMINOUS CONCRETE SIDEWALK**

**ITEM # 0922501A BITUMINOUS CONCRETE DRIVEWAY**

Description: This item shall consist of bituminous concrete surfaced sidewalk or driveway constructed on a gravel or reclaimed miscellaneous aggregate base course in the locations and to the dimensions and details shown on the plans or as directed by the Engineer and in accordance with these specifications. This item shall also include the removal and disposal of existing bituminous pavement necessary for driveway replacement work.

Materials: Materials for this work shall conform to the following requirements:

1. Base Course: The material used for base course construction shall conform to the requirements of Section M.02.01 of the Form 816 for broken or crushed stone.
2. Bituminous Concrete Surface: Materials for this surface shall conform to the requirements of Section M.04, Class 2.

Construction Methods:

1. Sawcutting: Portions of the driveway or driveway aprons to be replaced shall be saw cut, and the existing pavement removed and disposed of by the Contractor.
2. Excavation: Excavation, including removal of any existing sidewalk, or driveway, shall be made to the required depth below the finished grade, as shown on the plans or as directed by the Engineer. All soft and yielding material shall be removed and replaced with suitable material.
3. Forms: When the bituminous concrete is spread by hand, forms shall be used. Forms shall be of metal or wood, straight, free from warp and of sufficient strength to resist springing from the impact of the roller. If made of wood, they shall be of 2-inch (38-millimeter) surfaced plank except that at sharp curves thinner material may be used; if made of metal, they shall be of an approved section. All forms shall be of a depth equal to the depth of the sidewalks or driveways and shall be securely staked, braced, and held firmly to the required line and grade. All forms shall be cleaned and oiled each time they are used.
4. Base Course: Processed stone base course shall be uniformly spread to the required depth and thoroughly compacted with a roller with a mass of not less than 500 pounds (226 kilograms).
5. Bituminous Concrete Surface: The edges of existing pavement shall be painted with an asphalt emulsion prior to the placement of permanent pavement. Hot laid bituminous concrete shall be placed so as to give a three-inch compacted surface, or a surface that has a depth equal to the existing driveway surface, whichever is greater.

This surface shall be constructed in accordance with the requirements of Section 4.06, except that the material may be spread by hand and thoroughly compacted by multiple passes of a power-driven roller weighing (with a mass) of not less than 500 pounds (226 kilograms). The finished surface shall be free from waves or depressions.

6. Backfilling and Removal of Surplus Material: The sides of the sidewalk or driveway shall be backfilled

with suitable material thoroughly compacted and finished flush with the top of the sidewalk or driveway. All surplus material shall be removed and the site left in a neat and presentable condition to the satisfaction of the Engineer. In sections inaccessible to the roller, the base course, surface course and backfill shall be hand-tamped with tampers weighing not less than 12 pounds (with a mass of not less than 5.5 kilograms), the face of which shall not exceed 50 square inches (32,000 square millimeters) in area.

Method of Measurement: This work will be measured for payment as follows:

1. Bituminous Concrete Driveway—Bituminous Concrete Sidewalk: This work will be measured by the actual number of square yards of completed and accepted sidewalk or driveway.
2. Excavation: Excavation below the finished grade of the sidewalk or driveway, including removal and disposal of existing bituminous concrete, backfilling, and disposal of all surplus materials will not be measured for payment; but the cost shall be included in the price bid for the sidewalk or driveway. Excavation above the finished grade of a proposed sidewalk or driveway, when necessary for the proper installation, will be classified and paid for as described in the Section 2.02 of the Form 816.
3. Base Course: This work will not be measured for payment but the cost thereof shall be included in the price bid for the sidewalk or driveway.

Basis of Payment: This work will be paid for at the contract unit price per square yard (square meter) for "Bituminous Concrete Sidewalk" or "Bituminous Concrete Driveway," as the case may be, complete in place, which price shall include all excavation as specified above, backfill, disposal of surplus material, gravel or reclaimed miscellaneous aggregate base, and all equipment, tools, labor and materials incidental thereto.



**ITEM # 0944000A                      GRADING AND TOPSOILING**

Description: This work shall consist of furnishing, placing, and shaping topsoil in areas shown on the plans where directed by the Engineer. The topsoil shall be placed to the depth stated in the Contract or specifications.

Material: The material shall conform to the requirements of Article M.13.01.1 of the Form 816.

Construction Methods: The areas on which topsoil is to be placed shall be graded to a reasonably true surface and cleaned of all stones, brickbats, and other unsuitable materials. After areas have been brought to proper subgrade and approved by the Engineer or his agent, loam shall be spread to a depth as indicated in the Contract, or to a depth of no less than four inches, with due allowance made for settlement. All stones, roots, debris, sod, weeds, and other undesirable material shall be removed from the topsoil. After shaping and grading, all trucks and other equipment shall be excluded from the topsoiled area to prevent excessive compaction. The Contractor shall perform such work as required to provide a friable surface for seed germination and plant growth prior to seeding.

During hauling and spreading operations, the Contractor shall immediately remove any material dumped or spilled on the shoulders or pavement.

It shall be the Contractor's responsibility to restore to line, grade, and surface all eroded areas with approved material and to keep topsoiled areas in acceptable condition until the completion of the construction work.

Payment: This work will be measured for payment by the number of square yards of area on which the placing of the topsoil has been completed and the work accepted.

The limits of payment shall be to the slope limits as shown on the plans. In the absence of slope limits, the maximum area of measurement shall be the area extending two feet behind the sidewalk and the area between the sidewalk and edge of pavement. No payment shall be made outside of these limits unless the disturbance was directed or approved by the Engineer. No payment shall be made for areas disturbed for staging, storage of materials, or other area disturbed for the convenience of the Contractor.

This work will be paid for at the Contract unit price per square yard for "Grading and Topsoil", which price shall include all materials, equipment, tools, labor, and work incidental thereto.

**ITEM # 0950005A                      TURF ESTABLISHMENT**

General: The work included in this item shall consist of providing an accepted uniform stand of established perennial turf grasses or wetland vegetation by furnishing and placing fertilizer, seed, and mulch on all areas to be treated as shown on the plans or where designated by the Engineer.

The work will also include the installation of erosion control matting of the type indicated where shown on the plans or as directed by the Engineer.

Materials: The materials for this work shall conform to the requirements of Section M.13 of the Form 816, except as noted below.

Seed mix for roadside areas shall consist of 70% Red Fescue, 20% Kentucky Blue Grass, and 10% Perennial Rye Grass or other mix for high maintenance lawn areas as approved by the Engineer.

The wetland seed mix to be used shall be 25% New England Roadside Matrix Wet Meadow Seed Mix and 75% New England Erosion Control / Restoration Mix, as listed within New England Wetland Plants, Inc.'s catalog or approved equal.

Erosion Control Matting shall be a product approved by the Connecticut Department of Transportation for the intended application as described in the "Qualified Products List" publication, latest edition.

Hydroseeding, when required by the Engineer, shall be performed using a homogenous slurry consisting of wood fiber mulch, fertilizer, live seed, and organic tackifiers conforming to Section M.13 of the Form 816.

Material certificates shall be provided for all materials supplied under this item.

Construction Methods: Construction Methods shall be those established as agronomically acceptable and feasible and which are approved by the Engineer.

1. Preparation of the Seedbed:

(a) Level areas, medians, interchanges and lawns: These areas shall be made friable and receptive for seeding by disking or by other approved methods to the satisfaction of the Engineer. In all cases the final prepared and seeded soil surface shall meet the lines and grades for such surface as shown in the plans, or as directed by the Engineer.

(b) Slope and Embankment Areas: These areas shall be made friable and receptive to seeding by approved methods which will not disrupt the line and grade of the slope surface. In no event will seeding be permitted on hard or crusted soil surface.

(c) All areas to be seeded shall be reasonably free from weeds taller than 3 inches. Removal of weed growth from the slope areas shall be by approved methods, including hand-mowing, which do not rut or scar the slope surface, or cause excessive disruption of the slope line or grade. Seeding on level areas shall not be permitted until substantially all weed growth is removed. Seeding on slope areas shall not be permitted without removal or cutting of weed growth except by written permission of the Engineer.

2. Seeding Season: The calendar dates for seeding shall be:

Spring—March 15 to June 15

Fall—August 15 to October 15

All disturbed soil areas shall be treated during the seeding seasons as follows:

(a) Areas at final grade: Seeding will be accomplished.

(b) "Out-of-season" seedings shall be performed in the same manner as "in-season" seedings. Since acceptable turf establishment is less likely, the Contractor shall be responsible for "in-season" reseeding until the turf stand conforms to this specification.

(c) During "out-of-season" periods unseeded areas shall be treated in accordance with Section 2.10, Water Pollution Control.

3. Seeding Methods: The seed mixture shall be applied by any agronomically acceptable procedure. The rate of application shall be no less than 175 pounds per acre or according to manufacturer instructions. Fertilizer conforming to M.13.03 shall be initially applied at a rate of 320 pounds per acre during or preceding seeding. When wood fiber mulch is used, it shall be applied in a water slurry at a rate of 2,000 pounds per acre with or immediately after the application of seed, fertilizer and limestone.

When hydroseeding is required by the Engineer, it shall be performed by a qualified Contractor who has a minimum of three year experience in the successful performance of this work and has been approved by the Engineer. Hydroseed mix shall be applied in a slurry consisting of wood fiber mulch, fertilizer, live seed, and organic tackifiers with each component applied at the rate described above. The slurry shall be hydraulically sprayed on the soil surface as required to form a blotter-like ground cover with a uniform coating. Contractor shall exercise special care as required to prevent slurry from being sprayed onto adjacent paved areas, sidewalks, buildings, or signs. All slurry sprayed onto adjacent surfaces shall be cleaned at the Contractor's expense.

When the grass seeding growth has attained a height of 6 inches, the specified areas designated herein shall be mowed to a height of 3 inches. Following mowing, all seeding grass areas (mowed and un-mowed) shall receive a uniform application of fertilizer hydraulically placed at the rate of 320 pounds per acre.

4. Compaction: The Contractor shall keep all equipment and vehicular and pedestrian traffic off areas that have been seeded to prevent excessive compaction and damage to young plants. Where such compaction has occurred, the Contractor shall rework the soil to make a suitable seedbed; then re-seed and mulch such areas with the full amounts of the specified materials, at no extra expense to the State.

5. Stand of Perennial Turf Grasses: The Contractor shall provide and maintain a uniform stand of established turf grass or wetland vegetation having attained a height of 6 inches consisting of no less than 100 plants per square foot throughout the seeded areas until the entire project has been accepted.

6. Establishment: The Contractor shall keep all seeded areas free from weeds and debris, such as stones, cables, baling wire, and he shall mow at his own expense, on a one-time-only basis, all slopes 4:1 or less (flatter) and level turf established (seeded) areas to a height of 3 inches when the grass growth attains a height of 6 inches. Clean-up shall include, but not be limited to, the removal of all debris from the turf establishment operations on the shoulders, pavement, and/or elsewhere on adjacent properties publicly and privately owned.

7. Erosion Control Matting: Erosion control matting shall be installed following seeding where called for on the plans or as directed by the Engineer. Staples shall be installed as per Manufacturer's recommendations. Where two lengths of matting are joined, the end of the up-grade strip shall overlap the down-grade strip. The Contractor shall maintain and protect the areas with erosion control matting until such time as the turf grass is established. The Contractor shall replace or repair at his own expense any and all erosion control matting areas damaged by fire, water or other causes including the operation of construction equipment. No mowing will be required in the locations where erosion control matting is installed.

Method of Measurement: This work will be measured for payment by the number of square yards of surface area of accepted established perennial turf grass or wetland vegetation as specified or by the number of square yards surface area of seeding actually covered and as specified.

Restoration of areas disturbed for staging, storage of materials, or other area disturbed for the convenience of the Contractor will not be measured for payment.

Erosion control matting will be measured by the number of square of surface area of erosion control matting installed and accepted.

Basis of Payment: This work will be paid for at the contract unit price per square yard for "Turf Establishment", "Turf Establishment-Hydroseeding" or "Wetland Seeding", which price shall include all materials, mowing, maintenance, equipment, tools, labor, and work incidental thereto. Partial payment of up to 60% may be made for work completed, but not accepted.

Erosion control matting will be paid for at the contract unit price per square yard for "Erosion Control Matting" complete in place and accepted, which price shall include the hay mulch, netting, staples, maintenance, equipment, tools, labor, and work incidental thereto.

**ITEM # 0970006A                      TRAFFICPERSON (MUNICIPAL POLICE OFFICER)**

**ITEM # 0970007A                      TRAFFICPERSON (UNIFORMED FLAGGER)**

This item shall conform to Section 9.70 TRAFFICPERSON, of the Form 816, amended as follows:

Description: Add the following to the first paragraph of Section 9.70.01

“Trafficpersons shall consist of uniformed flaggers meeting acceptable criteria or extra duty officers of the Glastonbury Police Department. The Contractor shall provide Uniformed Flaggers meeting the requirements of this specification as required for safe traffic operations in the project area. Extra-duty police officers will be used only when specifically required by the Police Chief, as the Local Traffic Authority, who will make this determination based on the Contractor’s proposed operations, traffic volumes, and traffic conditions.”

“All work under this item shall be paid only for the duration of the Contract as contained in the Special Conditions under ‘Time for Completion/Notice to Proceed’ and for any time extensions granted in writing by the Town. Payment for police officers required after the duration of the Contract and approved time extensions shall be made directly by the Town and such costs deducted from future payments due the Contractor.”

Basis of Payment: Replace Section 9.70.05 with the following:

“There will be no direct payment for safety garments or STOP/SLOW paddles. All costs associated with furnishing safety garments and STOP/SLOW paddles shall be considered included in the general cost of the item.

1. Trafficperson - Uniformed Flagger: Uniformed flaggers will be paid for at the contract unit price per hour for “Trafficperson (Uniformed Flagger)” as listed in the bid proposal, which price shall include all compensation, insurance benefits, and any other cost or liability incidental to the furnishing of the trafficpersons ordered.”

2. Trafficperson - Police Officer: The sum of money shown on the bid proposal as "Estimated Cost" for this work will be considered the bid price even though payment will be made as described below. The estimated cost figure is not to be altered in any manner by the bidder. Should the bidder alter the amount shown, the altered figures will be disregarded and the original price will be used to determine the total amount for the contract.

Police Officers will be paid for at the actual hourly rate charged for extra-duty police officers services by the Town (monthly statement or receipted bills) plus a 5% markup. Use of a Town police vehicle requested by the Engineer will be paid at the actual rate charged by the Town plus a 5% markup. The rate charged by the Town for use of a Uniformed Town Police Officer and/or an official Town Police vehicle shall not be greater than the rate it normally charges others for similar services.

**ITEM # 0971001A                      MAINTENANCE AND PROTECTION OF TRAFFIC**

**Article 9.71.01 – Description is supplemented by the following:**

The Contractor shall maintain and protect traffic as described by the following and as limited in the Special Provision "Prosecution and Progress":

***The Town of Glastonbury CHIEF OF POLICE, acting in the capacity of the LOCAL TRAFFIC AUTHORITY, shall be the sole and final authority for the Maintenance and Protection of Traffic.***

**All Roadways**

The Contractor shall maintain and protect a minimum of one lane of traffic in each direction, each lane on a paved travel path not less than 11 feet in width.

Excepted therefrom will be those periods, during the allowable periods, when the Contractor is actively working, at which time the Contractor shall maintain and protect at least an alternating one-way traffic operation, on a paved travel path not less than 11 feet in width. The length of the alternating one-way traffic operation shall not exceed 300 feet and there shall be no more than one alternating one-way traffic operation within the project limits without prior approval of the Engineer.

**Commercial and Residential Driveways**

The Contractor shall maintain access to and egress from all commercial and residential driveways throughout the project limits. The Contractor will be allowed to close said driveways to perform the required work during those periods when the businesses are closed, unless permission is granted from the business owner to close the driveway during business hours. If a temporary closure of a residential driveway is necessary, the Contractor shall coordinate with the owner to determine the time period of the closure.

**Article 9.71.03 - Construction Method is supplemented as follows:**

**General**

The Contractor shall schedule operations such that all open excavations are backfilled or steel plated by the end of each active work period. The installation of steel plates shall be approved by the Town of Glastonbury Public Works Department prior to installation. Trenches and other excavations within the travelway that are backfilled shall be brought up to finished grade and paved with bituminous concrete pavement prior to reopening the roadway to vehicular traffic.

When the Contractor is excavating adjacent to the roadway, the Contractor shall provide a 3-foot shoulder between the work area and travel lanes, with traffic drums spaced every 20 feet. At the end of the workday, if the vertical drop-off exceeds 3 inches, the Contractor shall provide a temporary traversable slope of 4:1 or flatter that is acceptable to the Engineer.

The Contractor, during the course of active construction work on overhead signs and structures, shall close the lanes directly below the work area for the entire length of time overhead work is being undertaken. At no time shall an overhead sign be left partially removed or installed.

If applicable, when an existing sign is removed, it shall be either relocated or replaced by a new sign during the same working day.

The Contractor shall not store any material on-site which would present a safety hazard to motorists or pedestrians (e.g. fixed object or obstruct sight lines).

The field installation of a signing pattern shall constitute interference with existing traffic operations and shall not be allowed, except during the allowable periods.

### **Traffic Signals**

Loop detectors disturbed by the Contractor's operations shall be made operational, in accordance with the special provision for Item No. 1111451A – Loop Detector Saw Cut, or temporary detection shall be provided within 24 hours of the termination of the existing loop detectors.

### **Existing Signing**

The Contractor shall maintain all existing overhead and side-mounted signs throughout the project limits during the duration of the project. The Contractor shall temporarily relocate signs and sign supports as many times as deemed necessary, and install temporary sign supports if necessary and as directed by the Engineer.

### **Signing Patterns**

The Contractor shall erect and maintain all signing patterns in accordance with the traffic control plans contained herein. Proper distances between advance warning signs and proper taper lengths are mandatory. 42-inch traffic cones and approved traffic drums are to be utilized for lane closures.

### **Requirements for Winter**

The Contractor shall schedule a meeting with representatives from the Town of Glastonbury to determine what interim traffic control measures the Contractor shall accomplish for the winter to provide safety to the motorists and permit adequate snow removal procedures. This meeting shall be held prior to October 31 of each year and will include, but not be limited to, discussion of the status and schedule of the following items: lane and shoulder widths, pavement restoration, traffic signal work, pavement markings, and signing.

## **TRAFFIC CONTROL DURING CONSTRUCTION OPERATIONS**

The following guidelines shall assist field personnel in determining when and what type of traffic control patterns to use for various situations. These guidelines shall provide for the safe and efficient movement of traffic through work zones and enhance the safety of work forces in the work area.

### **TRAFFIC CONTROL PATTERNS**

Traffic control patterns shall be used when a work operation requires that all or part of any vehicle or work area protrudes onto any part of a travel lane or shoulder. For each situation, the installation of traffic control devices shall be based on the following:

- Speed and volume of traffic
- Duration of operation
- Exposure to hazards

Traffic control patterns shall be uniform, neat and orderly so as to command respect from the motorist.

In the case of a horizontal or vertical sight restriction in advance of the work area, the traffic control pattern shall be extended to provide adequate sight distance for approaching traffic.

If a lane reduction taper is required to shift traffic, the entire length of the taper should be installed on a tangent section of roadway so that the entire taper area can be seen by the motorist.

Any existing signs that are in conflict with the traffic control patterns shall be removed, covered, or turned so that they are not readable by oncoming traffic.

When installing a traffic control pattern, a Buffer Area should be provided and this area shall be free of equipment, workers, materials and parked vehicles.

Typical traffic control plans 19 through 25 may be used for moving operations such as line striping, pot hole patching, mowing, or sweeping when it is necessary for equipment to occupy a travel lane.

Traffic control patterns will not be required when vehicles are on an emergency patrol type activity or when a short duration stop is made and the equipment can be contained within the shoulder. Flashing lights and appropriate trafficperson shall be used when required.

Although each situation must be dealt with individually, conformity with the typical traffic control plans contained herein is required. In a situation not adequately covered by the typical traffic control plans, the Contractor must contact the Engineer for assistance prior to setting up a traffic control pattern.

### **PLACEMENT OF SIGNS**

Signs must be placed in such a position to allow motorists the opportunity to reduce their speed prior to the work area. Signs shall be installed on the same side of the roadway as the work area. On multi-lane divided highways, advance warning signs shall be installed on both sides of the highway. On directional roadways (on-ramps, off-ramps, one-way roads), where the sight distance to signs is restricted, these signs should be installed on both sides of the roadway.

### **ALLOWABLE ADJUSTMENT OF SIGNS AND DEVICES SHOWN ON THE TRAFFIC CONTROL PLANS**

The traffic control plans contained herein show the location and spacing of signs and devices under ideal conditions. Signs and devices should be installed as shown on these plans whenever possible.

The proper application of the traffic control plans and installation of traffic control devices depends on actual field conditions.

Adjustments to the traffic control plans shall be made only at the direction of the Engineer to improve the visibility of the signs and devices and to better control traffic operations.

Adjustments to the traffic control plans shall be based on safety of work forces and motorists, abutting property requirements, driveways, side roads, and the vertical and horizontal curvature of the roadway.

The Engineer may require that the traffic control pattern be located significantly in advance of the work area to provide better sight line to the signing and safer traffic operations through the work zone.

Table I indicates the minimum taper length required for a lane closure based on the posted speed limit of the roadway. These taper lengths shall only be used when the recommended taper lengths shown on the traffic control plans cannot be achieved.



**TABLE I – MINIMUM TAPER LENGTHS**

POSTED SPEED LIMIT MILES PER HOUR	MINIMUM TAPER LENGTH IN FEET FOR A SINGLE LANE CLOSURE
30 OR LESS	180
35	250
40	320
45	540
50	600
55	660
65	780

**SECTION 1. WORK ZONE SAFETY MEETINGS**

- 1.a) Prior to the commencement of work, a work zone safety meeting will be conducted with representatives of DOT Construction, Connecticut State Police (Local Barracks), Municipal Police, the Contractor (Project Superintendent) and the Traffic Control Subcontractor (if different than the prime Contractor) to review the traffic operations, lines of responsibility, and operating guidelines which will be used on the project. Other work zone safety meetings during the course of the project should be scheduled as needed.
- 1.b) A Work Zone Safety Meeting Agenda shall be developed and used at the meeting to outline the anticipated traffic control issues during the construction of this project. Any issues that can't be resolved at these meetings will be brought to the attention of the District Engineer and the Office of Construction. The agenda should include:
- Review Project scope of work and time
  - Review Section 1.08, Prosecution and Progress
  - Review Section 9.70, Trafficpersons
  - Review Section 9.71, Maintenance and Protection of Traffic
  - Review Contractor's schedule and method of operations.
  - Review areas of special concern: ramps, turning roadways, medians, lane drops, etc.
  - Open discussion of work zone questions and issues
  - Discussion of review and approval process for changes in contract requirements as they relate to work zone areas

**SECTION 2. GENERAL**

- 2.a) If the required minimum number of signs and equipment (i.e. one High Mounted Internally Illuminated Flashing Arrow for each lane closed, two TMAs, Changeable Message Sign, etc.) are not available; the traffic control pattern shall not be installed.
- 2.b) The Contractor shall have back-up equipment (TMAs, High Mounted Internally Illuminated Flashing Arrow, Changeable Message Sign, construction signs, cones/drums, etc.) available at all times in case of mechanical failures, etc. The only exception to this is in the case of sudden equipment breakdowns in which the pattern may be installed but the Contractor must provide replacement equipment within 24 hours.
- 2.c) Failure of the Contractor to have the required minimum number of signs, personnel and equipment, which results in the pattern not being installed, shall not be a reason for a time extension or claim for loss time.
- 2.d) In cases of legitimate differences of opinion between the Contractor and the Inspection staff, the Inspection staff shall err on the side of safety. The matter shall be brought to the District Office for

resolution immediately or, in the case of work after regular business hours, on the next business day.

### **SECTION 3. INSTALLING AND REMOVING TRAFFIC CONTROL PATTERNS**

- 3.a) Lane Closures shall be installed beginning with the advanced warning signs and proceeding forward toward the work area.
- 3.b) Lane Closures shall be removed in the reverse order, beginning at the work area, or end of the traffic control pattern, and proceeding back toward the advanced warning signs.
- 3.c) Stopping traffic may be allowed:
  - As per the contract for such activities as blasting, steel erection, etc.
  - During paving, milling operations, etc. where, in the middle of the operation, it is necessary to flip the pattern to complete the operation on the other half of the roadway and traffic should not travel across the longitudinal joint or difference in roadway elevation.
  - To move slow moving equipment across live traffic lanes into the work area.
- 3.d) Under certain situations when the safety of the traveling public and/or that of the workers may be compromised due to conditions such as traffic volume, speed, roadside obstructions, or sight line deficiencies, as determined by the Engineer and/or State Police, traffic may be briefly impeded while installing and/or removing the advanced warning signs and the first ten traffic cones/drums only. Appropriate measures shall be taken to safely slow traffic. If required, traffic slowing techniques may be used and shall include the use of Truck Mounted Impact Attenuators (TMAs) as appropriate, for a minimum of one mile in advance of the pattern starting point. Once the advanced warning signs and the first ten traffic cones/drums are installed/removed, the TMAs and sign crew shall continue to install/remove the pattern as described in Section 4c and traffic shall be allowed to resume their normal travel.
- 3.e) The Contractor must adhere to using the proper signs, placing the signs correctly, and ensuring the proper spacing of signs.
- 3.f) Additional devices are required on entrance ramps, exit ramps, and intersecting roads to warn and/or move traffic into the proper travel path prior to merging/exiting with/from the main line traffic. This shall be completed before installing the mainline pattern past the ramp or intersecting roadway.
- 3.g) Prior to installing a pattern, any conflicting existing signs shall be covered with an opaque material. Once the pattern is removed, the existing signs shall be uncovered.
- 3.h) On limited access roadways, workers are prohibited from crossing the travel lanes to install and remove signs or other devices on the opposite side of the roadway. Any signs or devices on the opposite side of the roadway shall be installed and removed separately.

### **SECTION 4. USE OF HIGH MOUNTED INTERNALLY ILLUMINATED FLASHING ARROW**

- 4.a) On limited access roadways, one Flashing Arrow shall be used for each lane that is closed. The Flashing Arrow shall be installed concurrently with the installation of the traffic control pattern and its placement shall be as shown on the traffic control plan. For multiple lane closures, one Flashing

Arrow is required for each lane closed. If conditions warrant, additional Flashing Arrows should be employed (i.e.: curves, major ramps, etc.).

- 4.b) On non-limited access roadways, the use of a Flashing Arrow for lane closures is optional. The roadway geometry, sight line distance, and traffic volume should be considered in the decision to use the Flashing Arrow.
- 4.c) The Flashing Arrow shall not be used on two lane, two-way roadways for temporary alternating one-way traffic operations.
- 4.d) The Flashing Arrow board display shall be in the "arrow" mode for lane closure tapers and in the "caution" mode (four corners) for shoulder work, blocking the shoulder, or roadside work near the shoulder. The Flashing Arrow shall be in the "caution" mode when it is positioned in the closed lane.
- 4.e) The Flashing Arrow shall not be used on a multi-lane roadway to laterally shift all lanes of traffic, because unnecessary lane changing may result.

**SECTION 5. USE OF TRUCK MOUNTED IMPACT ATTENUATOR VEHICLES (TMAs)**

- 5.a) For lane closures on limited access roadways, a minimum of two TMAs shall be used to install and remove traffic control patterns. If two TMAs are not available, the pattern shall not be installed.
- 5.b) On non-limited access roadways, the use of TMAs to install and remove patterns closing a lane(s) is optional. The roadway geometry, sight line distance, and traffic volume should be considered in the decision to utilize the TMAs.
- 5.c) Generally, to establish the advance and transition signing, one TMA shall be placed on the shoulder and the second TMA shall be approximately 1,000 feet ahead blocking the lane. The flashing arrow board mounted on the TMA should be in the "flashing arrow" mode when taking the lane. The sign truck and workers should be immediately ahead of the second TMA. In no case shall the TMA be used as the sign truck or a work truck. Once the transition is in place, the TMAs shall travel in the closed lane until all Changeable Message Signs, signs, Flashing Arrows, and cones/drums are installed. The flashing arrow board mounted on the TMA should be in the "caution" mode when traveling in the closed lane.
- 5.d) A TMA shall be placed prior to the first work area in the pattern. If there are multiple work areas within the same pattern, then additional TMAs shall be positioned at each additional work area as needed. The flashing arrow board mounted on the TMA should be in the "caution" mode when in the closed lane.
- 5.e) TMAs shall be positioned a sufficient distance prior to the workers or equipment being protected to allow for appropriate vehicle roll-ahead in the event that the TMA is hit, but not so far that an errant vehicle could travel around the TMA and into the work area. For additional placement and use details, refer to the specification entitled "Type 'D' Portable Impact Attenuation System". Some operations, such as paving and concrete repairs, do not allow for placement of the TMA(s) within the specified distances. In these situations, the TMA(s) should be placed at the beginning of the work area and shall be advanced as the paving or concrete operations proceed.
- 5.f) TMAs should be paid in accordance with how the unit is utilized. When it is used as a TMA and is in the proper location as specified, and then it should be paid at the specified hourly rate for "Type 'D' Portable Impact Attenuation System". When the TMA is used as a Flashing Arrow, it should be paid at the daily rate for "High Mounted Internally Illuminated Flashing Arrow". If a TMA is used to install and remove a pattern and then is used as a Flashing Arrow, the unit should be paid as a "Type 'D'

Portable Impact Attenuation System” for the hours used to install and remove the pattern, typically 2 hours (1 hour to install and 1 hour to remove), and is also paid for the day as a “High Mounted Internally Illuminated Flashing Arrow”.

#### **SECTION 6. USE OF TRAFFIC DRUMS AND TRAFFIC CONES**

- 6.a) Traffic drums shall be used for taper channelization on limited-access roadways, ramps, and turning roadways and to delineate raised catch basins and other hazards.
- 6.b) Traffic drums shall be used in place of traffic cones in traffic control patterns that are in effect for more than a 36-hour duration.
- 6.c) Traffic Cones less than 42 inches in height shall not be used on limited-access roadways or on non-limited access roadways with a posted speed limit of 45 mph and above.
- 6.d) Typical spacing of traffic drums and/or cones shown on the Traffic Control Plans in the Contract are maximum spacings and may be reduced to meet actual field conditions as required.

#### **9.71.03 Construction Methods**

##### **Signing Patterns**

The Contractor shall provide such safety measures, pavement markings, traffic control devices, incidental flagmen, and signs deemed necessary to safeguard and guide the traveling public through the work zones as ordered by the Engineer, included in the approved maintenance scheme, or as shown on the plan. The Contractor shall erect, maintain, move, adjust, clean, relocate, store all signs, barricades, drums, traffic cones, and delineators when, where, and as directed by the Engineer. The use of unauthorized or unapproved signs, barricades, drums, traffic cones, or delineators will not be permitted.

All signs in any one signing pattern shall be mounted at the same height above the pavement. The Contractor shall keep all signs in proper position, clean and legible at all times. The Contractor shall maintain the site so that no weeds, shrubbery, construction materials, equipment or soil will obscure any sign, light, or barricade. Signs that no longer pertain to the project conditions shall be removed or adjusted from the view of traffic. Traffic drums shall be used in place of traffic cones in traffic control patterns that are in effect for more than a 72-hour duration. Traffic drums shall be used to delineate raised catch basins and other hazards.

##### **Pavement Markings**

During construction, the Contractor shall maintain all pavement markings on paved surfaces on all roadways throughout the limits of the project.

The Contractor should install painted pavement markings on the final course of bituminous concrete pavement by the end of the work day/night. If the painted pavement markings are not installed by the end of the work day/night, then Temporary Plastic Pavement Marking Tape shall be installed as described above and the painted pavement markings shall be installed by the end of the work day/night on Friday of that week.

If Temporary Plastic Pavement Marking Tape is installed, the Contractor shall remove and dispose of these markings when the painted pavement markings are installed. The cost of furnishing, installing and removing the Temporary Plastic Pavement Marking Tape shall be at the Contractor's expense.

NOTE: Painted pavement markings will not be allowed as a substitution for either the permanent pavement markings or the Temporary Plastic Pavement Marking Tape on the final course of bituminous concrete pavement.

**Dust Control**

The Contractor shall be responsible for taking all steps necessary to minimize dust emanating from the project and for keeping the street free of accumulations of sand or similar materials. When ordered by the Engineer, the Contractor shall remove snow and take care of ice on temporary, new and existing sidewalks within the limits of the project. No additional payment will be made for this work.

**Article 9.71.05 – Basis of Payment**

When the item of "Maintenance and Protection of Traffic" appears in the contract, this work will be paid for at the contract lump sum price for "Maintenance and Protection of Traffic." This price shall include all material, equipment, tools, labor, transportation, operations and all work incidental thereto. The amount of the lump sum paid in any given period shall be proportional to the percentage of the total of all other work completed. All materials including construction signs, barricades, traffic cones, traffic drums, and miscellaneous materials associated with the Work in this Item, and the costs for labor, equipment and services involved in the erection, maintenance, moving, adjusting, cleaning, relocating and storing of signs, barricades, drums, traffic cones and delineators furnished by the Contractor as well as all costs of labor and equipment involved in the maintenance of traffic lanes and detours, except for pavement markings, ordered or included in the approved scheme for maintenance of traffic.

Should the Contractor fail to perform any of the work required under this item, the Town may perform or arrange for others to perform such work. In those instances, the Town will deduct money due or money to become due to the contractor all expenses connected with the execution of this work. This money shall be deducted even if the Town expense exceeds the price bid for this work by the Contractor.

The contract lump sum price for "Maintenance and Protection of Traffic" shall also include temporarily relocating existing signs and sign supports as many times as deemed necessary and furnishing, installing, and removing temporary sign supports and foundations if necessary during construction of the project.

### NOTES FOR TRAFFIC CONTROL PLANS

1. IF A TRAFFIC STOPPAGE OCCURS IN ADVANCE OF SIGN (A), THEN AN ADDITIONAL SIGN (A) SHALL BE INSTALLED IN ADVANCE OF THE STOPPAGE.
2. SIGNS (AA), (A), AND (D) SHOULD BE OMITTED WHEN THESE SIGNS HAVE ALREADY BEEN INSTALLED TO DESIGNATE A LARGER WORK ZONE THAN THE WORK ZONE THAT IS ENCOMPASSED ON THIS PLAN.
3. SEE TABLE 1 FOR ADJUSTMENT OF TAPERS IF NECESSARY.
4. IF THIS PLAN REMAINS IN CONTINUOUS OPERATION FOR MORE THAN 36 HOURS, THEN TRAFFIC DRUMS SHALL BE USED IN PLACE OF TRAFFIC CONES.
5. ANY LEGAL SPEED LIMIT SIGNS WITHIN THE LIMITS OF A ROADWAY / LANE CLOSURE AREA SHALL BE COVERED WITH AN OPAQUE MATERIAL WHILE THE CLOSURE IS IN EFFECT, AND UNCOVERED WHEN THE ROADWAY / LANE CLOSURE IS RE-OPENED TO ALL LANES OF TRAFFIC.
6. IF THIS PLAN REMAINS IN CONTINUOUS OPERATION FOR MORE THAN 36 HOURS, THEN ANY EXISTING CONFLICTING PAVEMENT MARKINGS SHALL BE ERADICATED OR COVERED, AND TEMPORARY PAVEMENT MARKINGS THAT DELINEATE THE PROPER TRAVELPATHS SHALL BE INSTALLED.
7. DISTANCES BETWEEN SIGNS IN THE ADVANCE WARNING AREA MAY BE REDUCED TO 100' ON LOW-SPEED URBAN ROADS (SPEED LIMIT < 40 MPH).
8. IF THIS PLAN IS TO REMAIN IN OPERATION DURING THE HOURS OF DARKNESS, INSTALL BARRICADE WARNING LIGHTS - HIGH INTENSITY ON ALL POST-MOUNTED DIAMOND SIGNS IN THE ADVANCE WARNING AREA.
9. A CHANGEABLE MESSAGE SIGN SHALL BE INSTALLED ONE HALF TO ONE MILE IN ADVANCE OF THE LANE CLOSURE TAPER.
10. SIGN (P) SHALL BE MOUNTED A MINIMUM OF 7 FEET FROM THE PAVEMENT SURFACE TO THE BOTTOM OF THE SIGN.

TABLE 1 - MINIMUM TAPER LENGTHS

POSTED SPEED LIMIT (MILES PER HOUR)	MINIMUM TAPER LENGTH FOR A SINGLE LANE CLOSURE
30 OR LESS	180' (55m)
35	250' (75m)
40	320' (100m)
45	540' (165m)
50	600' (180m)
55	660' (200m)
65	780' (240m)

METRIC CONVERSION CHART (1" = 25mm)

ENGLISH	METRIC	ENGLISH	METRIC	ENGLISH	METRIC
12"	300mm	42"	1050mm	72"	1800mm
18"	450mm	48"	1200mm	78"	1950mm
24"	600mm	54"	1350mm	84"	2100mm
30"	750mm	60"	1500mm	90"	2250mm
36"	900mm	66"	1650mm	96"	2400mm



SCALE: NONE

CONSTRUCTION TRAFFIC CONTROL PLAN

### NOTES

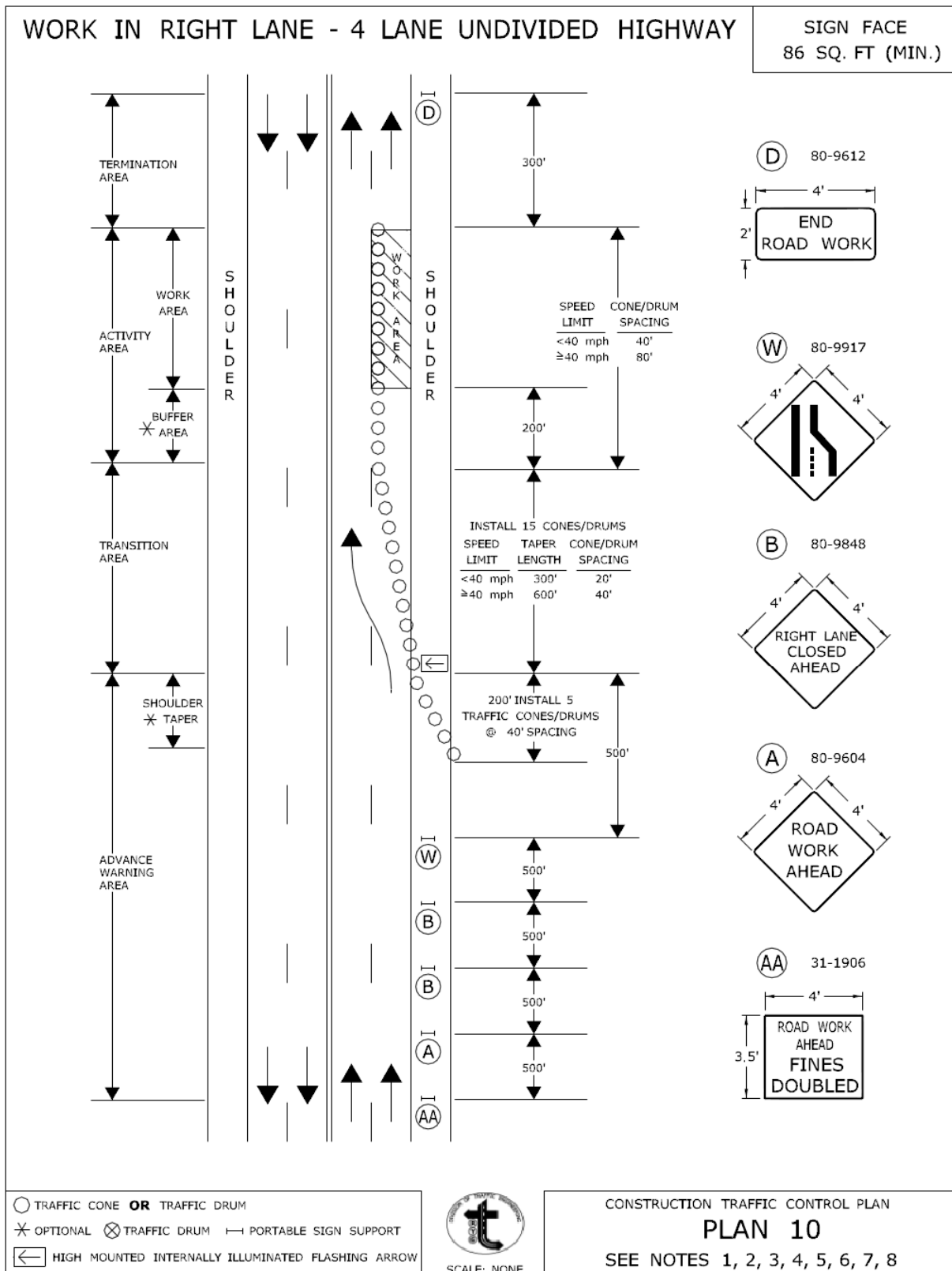

CONNECTICUT DEPARTMENT OF TRANSPORTATION  
BUREAU OF ENGINEERING & CONSTRUCTION

APPROVED *Charles S. Harlow* Charles S. Harlow  
2012.06.05 15:54:15-0400  
PRINCIPAL ENGINEER

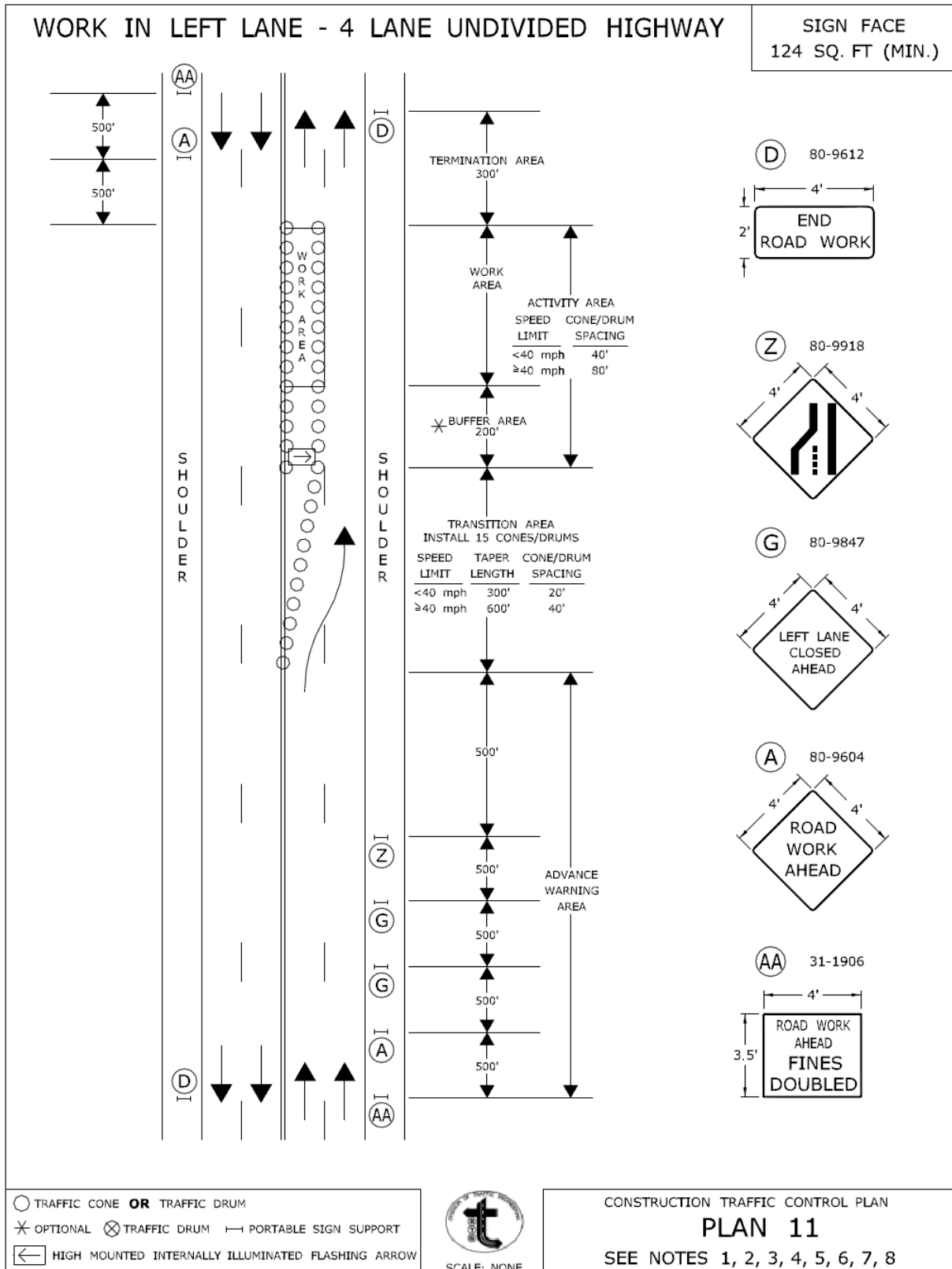

CONNECTICUT DEPARTMENT OF TRANSPORTATION  
BUREAU OF ENGINEERING & CONSTRUCTION

APPROVED *Charles S. Harlow*  
PRINCIPAL ENGINEER  
2012.08.05 15:54:36-0400'



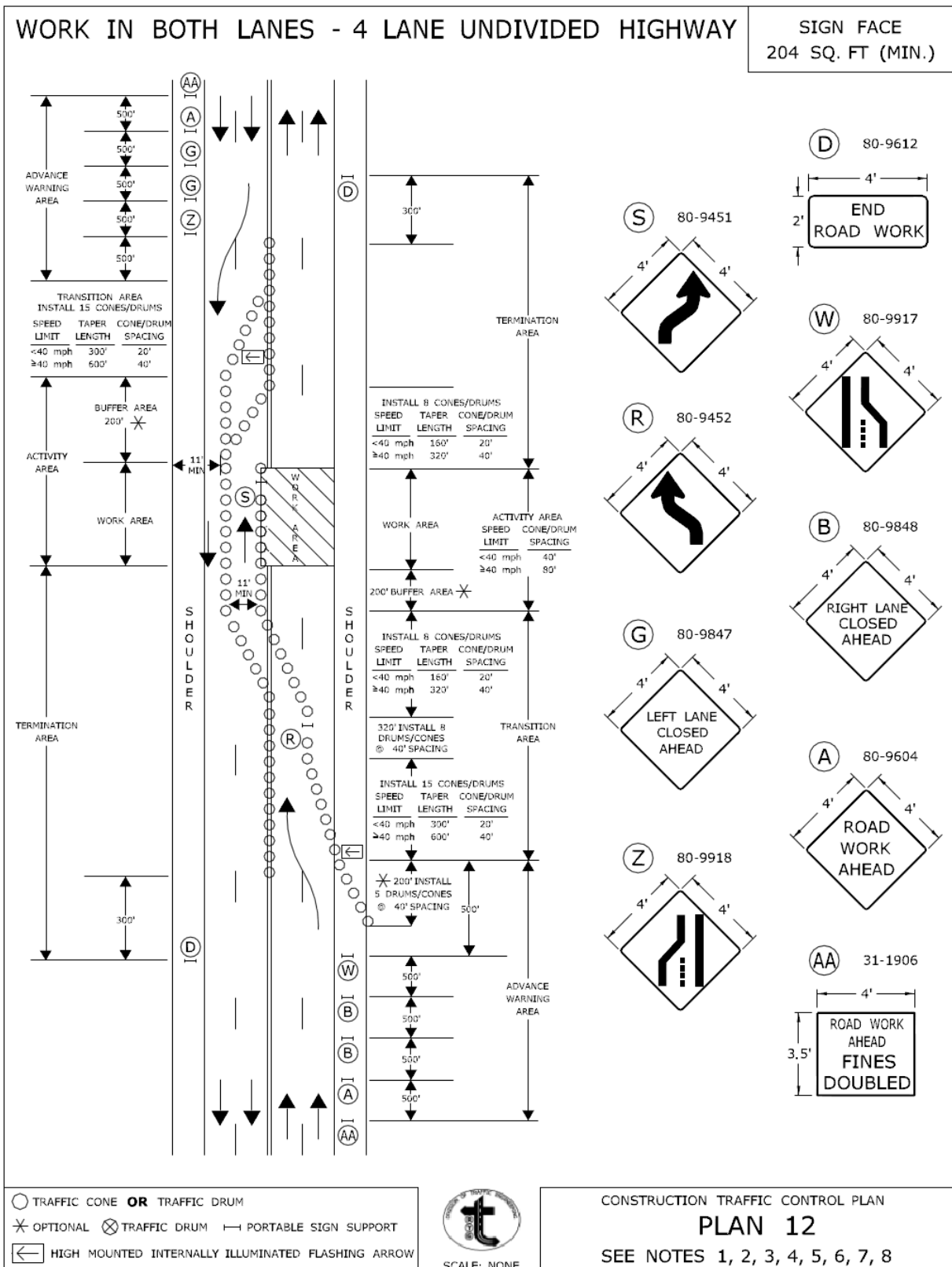

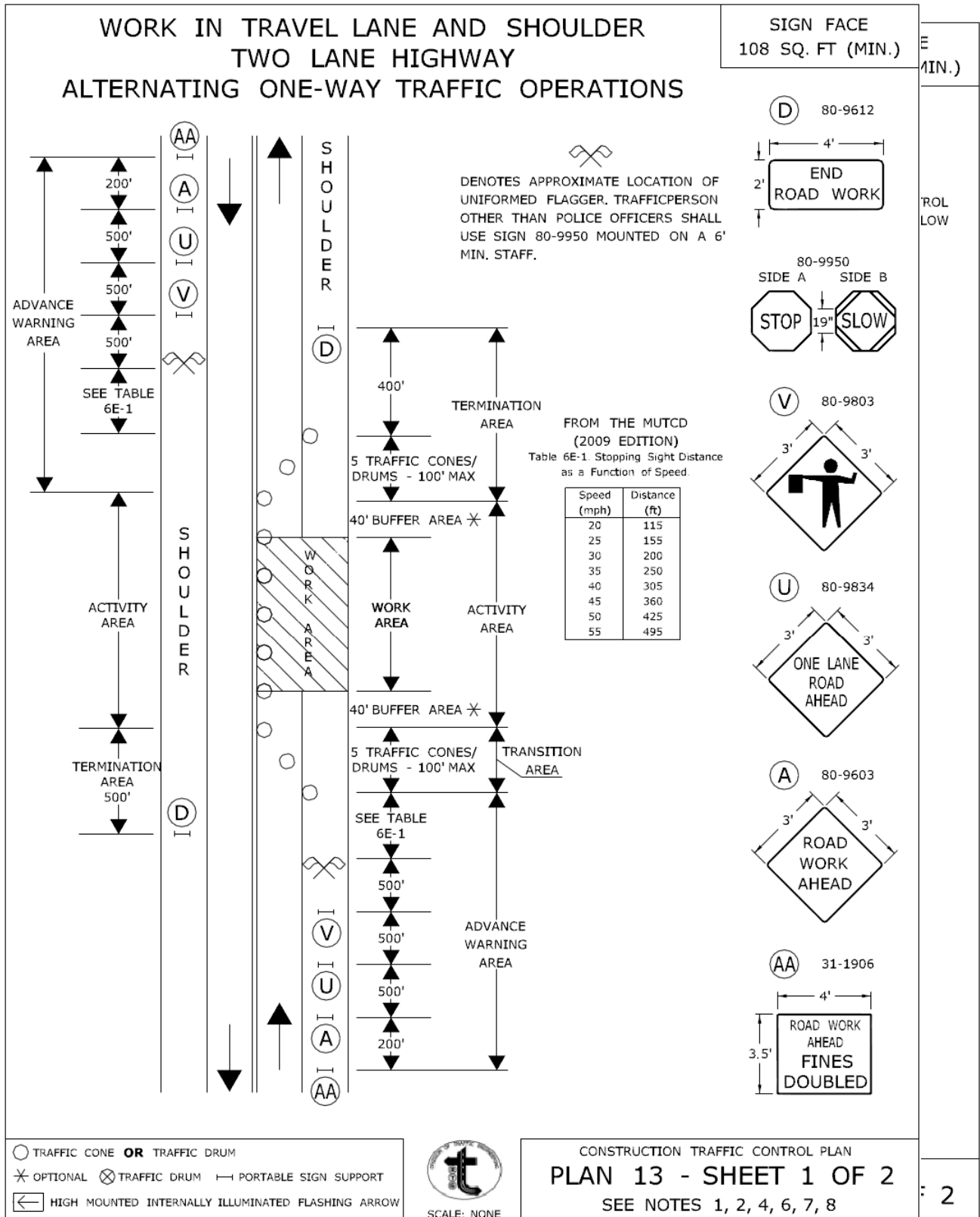

CONNECTICUT DEPARTMENT OF TRANSPORTATION  
BUREAU OF ENGINEERING & CONSTRUCTION  
BUREAU OF ENGINEERING & CONSTRUCTION

APPROVED *Charles S. Harlow* Charles S. Harlow  
2012.06.05 15:55:23-04'00"  
PRINCIPAL ENGINEER  
PRINCIPAL ENGINEER

15-04'00"

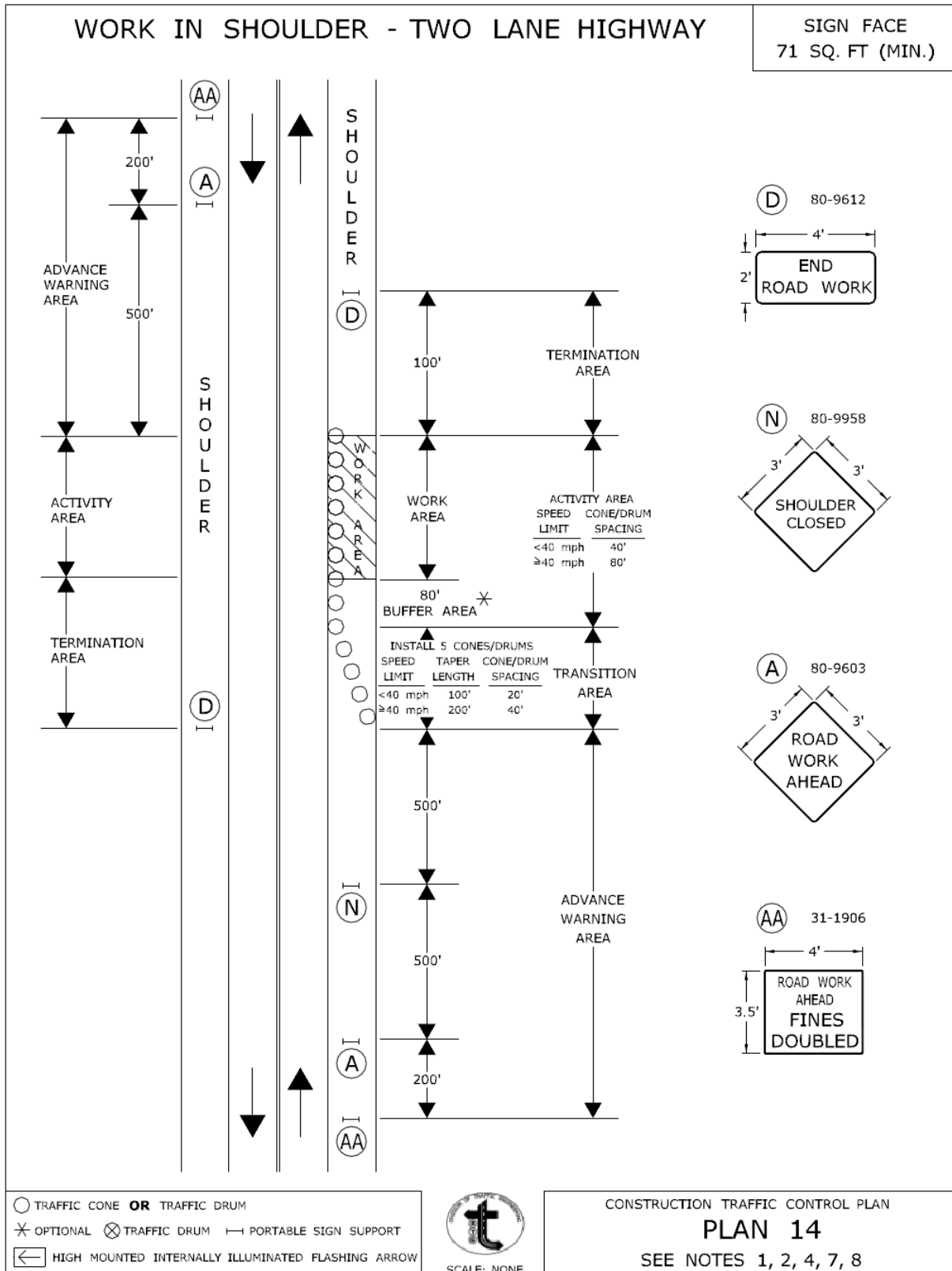

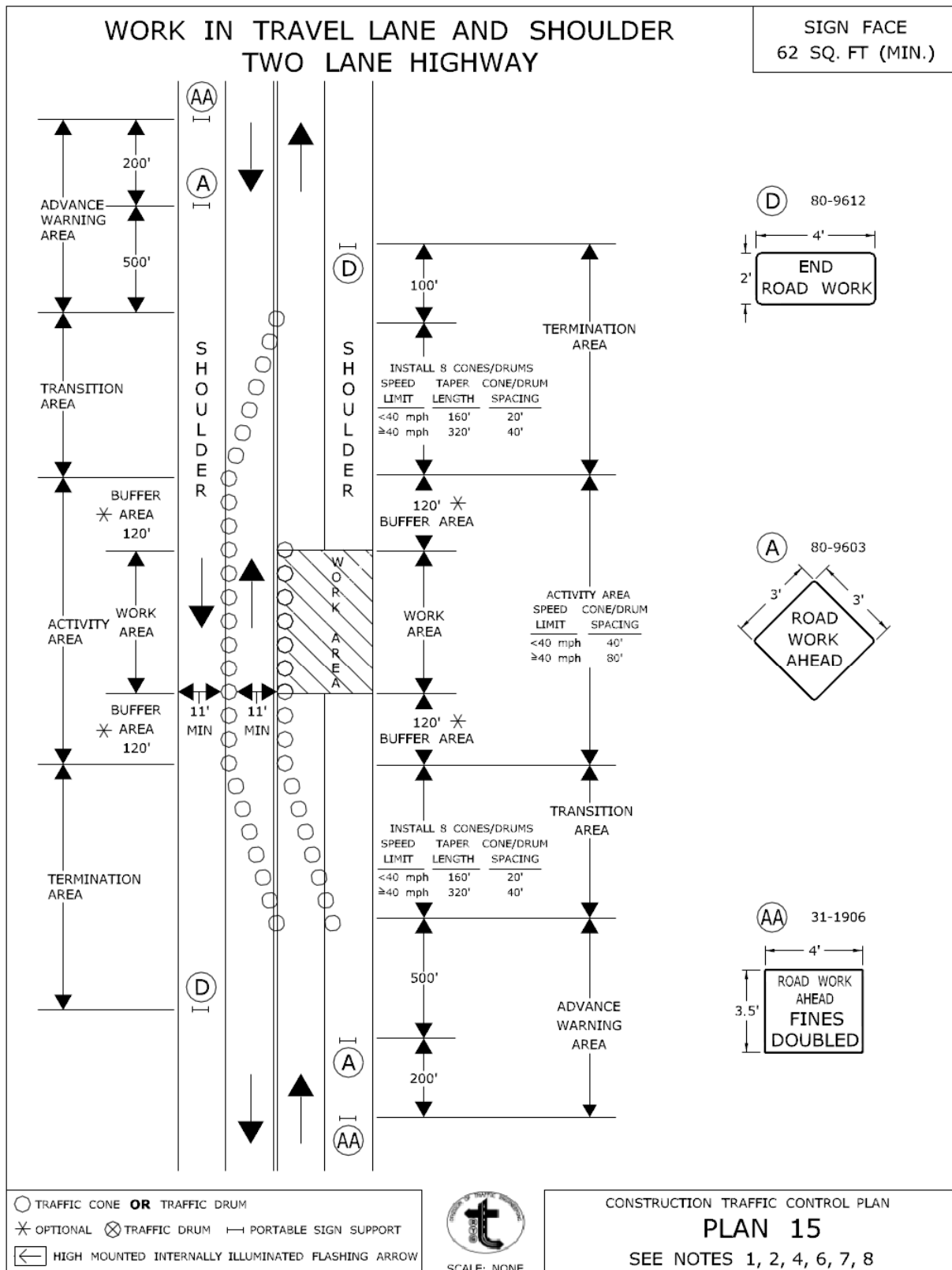

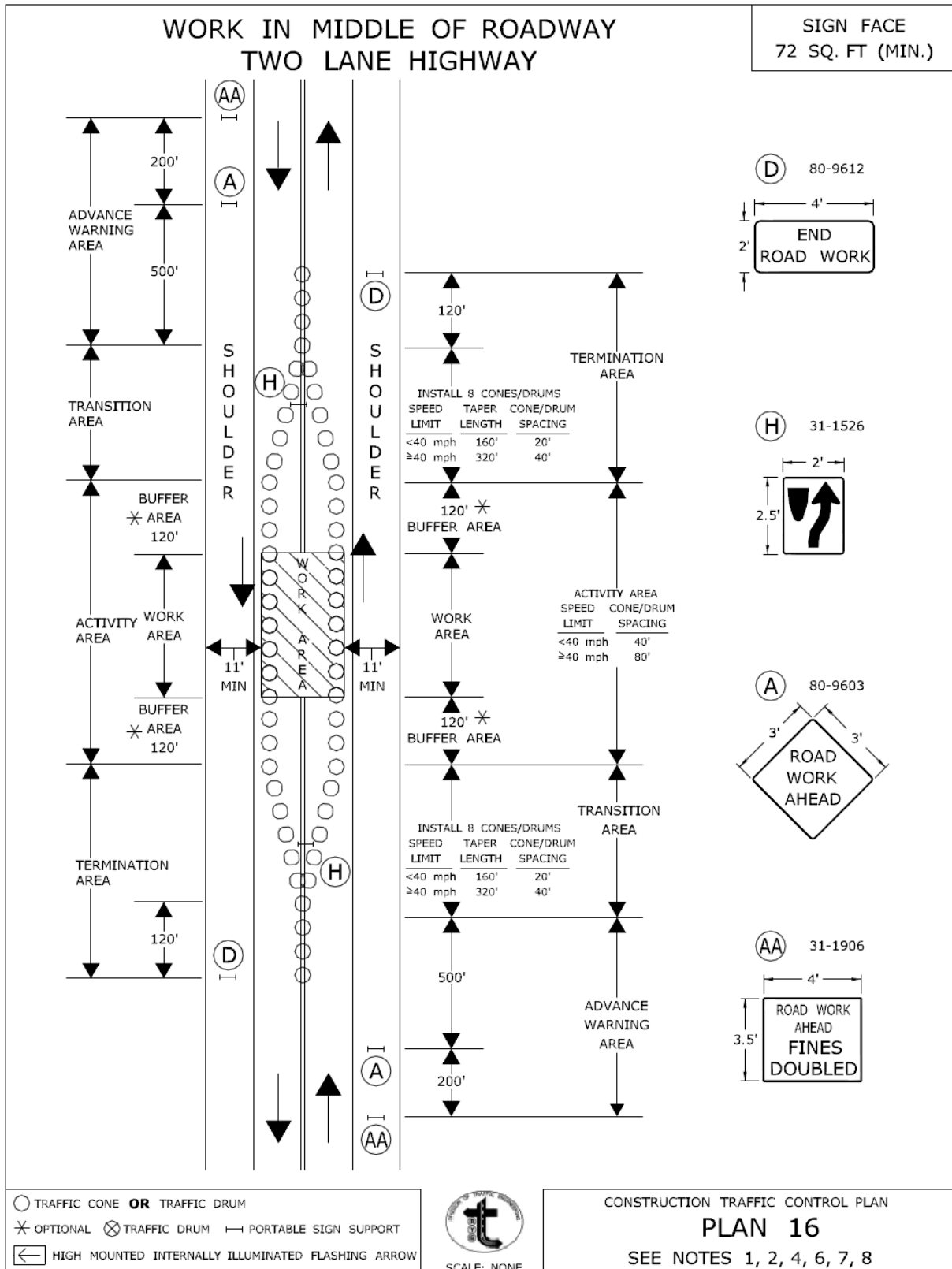

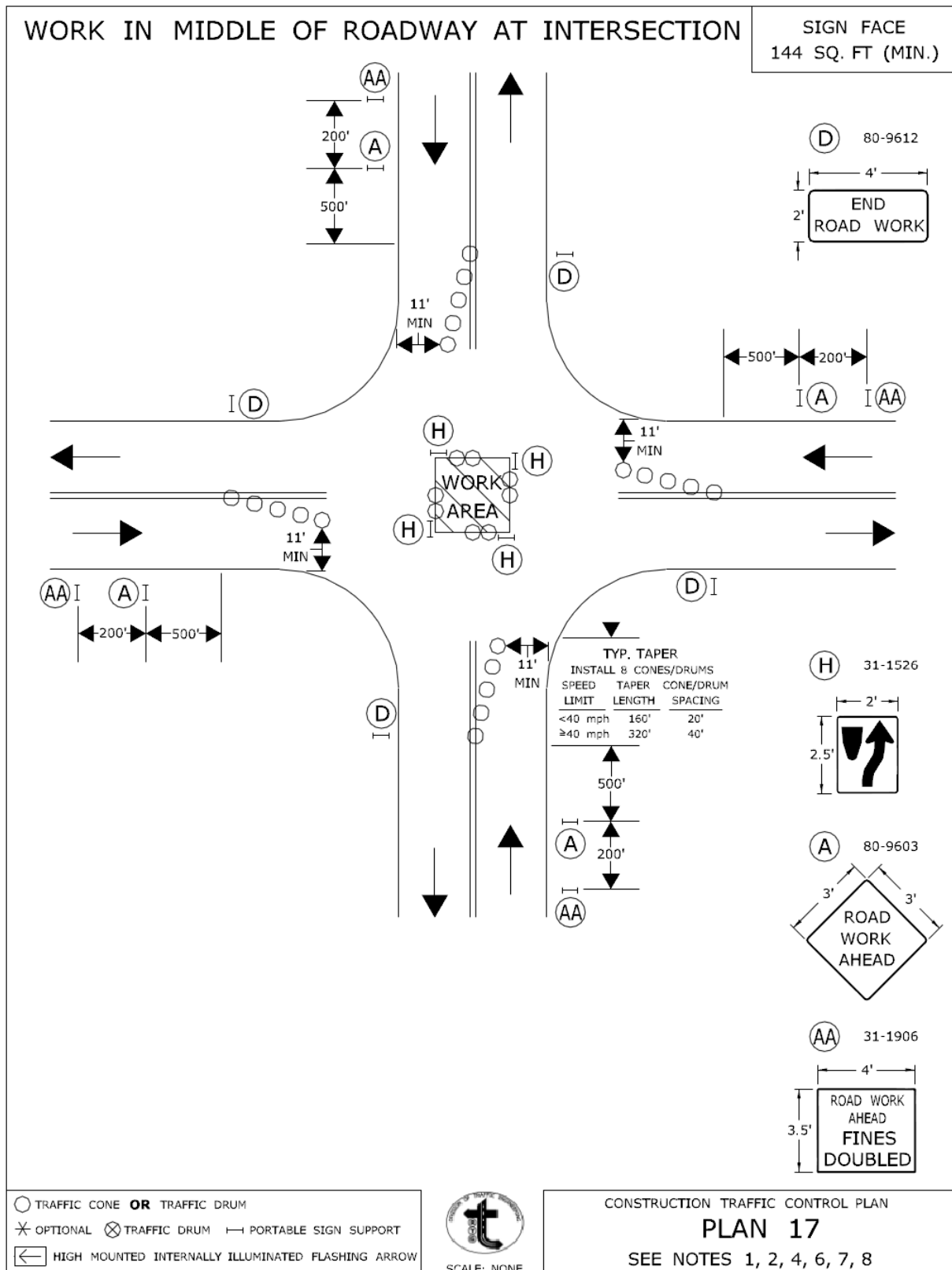

CONNECTICUT DEPARTMENT OF TRANSPORTATION  
BUREAU OF ENGINEERING & CONSTRUCTION

APPROVED *Charles S. Harlow* Charles S. Harlow  
2012.08.05 15:57:16-04'00"  
PRINCIPAL ENGINEER

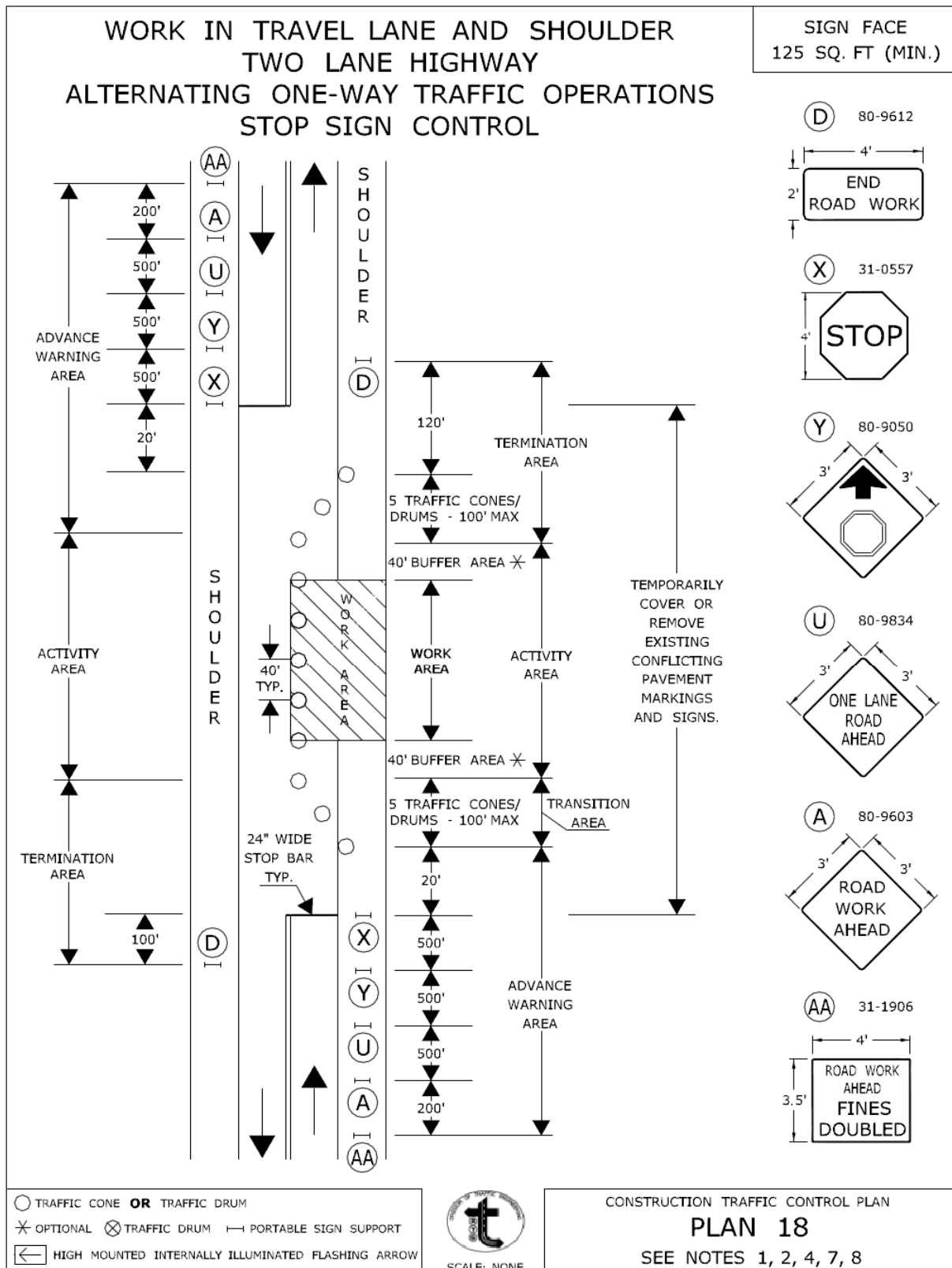

CONNECTICUT DEPARTMENT OF TRANSPORTATION  
BUREAU OF ENGINEERING & CONSTRUCTION

APPROVED *Charles S. Harlow* Charles S. Harlow  
2012.06.05 15:57:37-0400'  
PRINCIPAL ENGINEER

**ITEM # 0979003A**                      **CONSTRUCTION BARRICADE TYPE III**

General: The Contractor shall furnish construction barricades to conform to the requirements of NCHRP Report 350 (TL-3) and to the requirements stated in Article 9.71 "Maintenance and Protection of Traffic," as shown on the plans and/or as directed by the Engineer.

Materials: Prior to using the construction barricades, the Contractor shall submit to the Engineer a copy of the Letter of Acceptance issued by the FHWA to the manufacturer documenting that the devices conform to NCHRP Report 350 (TL-3).

Alternate stripes of white and orange Type III or Type VI reflective sheeting shall be applied to the horizontal members as shown on the plans. Application of the reflective sheeting shall conform to the requirements specified by the reflective sheeting manufacturer. Only one type of sheeting shall be used on a barricade and all barricades furnished shall have the same type of reflective sheeting. Reflective sheeting shall conform to the requirements of Article M.18.09.01.

Construction barricades shall be designed and fabricated so as to prevent them from being blown over or displaced by the wind from passing vehicles. Construction barricades shall be approved by the Engineer before they are used.

Construction Methods: Ineffective barricades, as determined by the Engineer and in accordance with the ATSSA guidelines contained in "Quality Standards for Work Zone Traffic Control Devices", shall be replaced by the Contractor at no cost to the State.

Barricades that are no longer required shall be removed from the project and shall remain the property of the Contractor.

Method of Measurement: Construction Barricade Type III will be measured for payment by the number of construction barricades required and used.

Basis of Payment: "Construction Barricade Type III" required and used will be paid for at the Contract unit price per each. Each barricade will be paid for once, regardless of the number of times it is used.



**ITEM # 1010052A                      CAST IRON HANDHOLE COVER**

**Article 10.10.05** - Basis of Payment:

After the words "Cast Iron Handhole Cover, insert the phrase "of the type called for".

**ITEM # 1017032A**                      **SERVICE (METERED)**

**Description:** Furnish and install a metered electric service at the location shown on the plans or as directed by the Engineer.

**Materials:**

Meter Socket  
UL listed  
Manual lever bypass  
Locking metal cover for the glass enclosure  
Contact the serving utility company for a list of approved meter sockets  
Conduit Bond Clamp  
UL listed  
Rated for direct burial

Locations served by United Illuminating (UI)  
Meter socket rated at 100 amps

Locations served by Connecticut Light and Power Co. (CL&P)  
Meter socket rated at 200 amps  
Enclosure capable of accepting a 3 inch (75 mm) rigid metal conduit (RMC)

**Construction Methods:**

Comply with the National Electric Code (NEC), the Department of Public Utility Regulatory Authority (PURA), and the serving power company requirements. Install a meter socket with associated equipment on the outside of the controller cabinet, as shown on the plans. Mount the enclosure approximately 54 inches (1.37 meters) above the ground. Install an expansion fitting in the RMC between the ground and the enclosure. Attach a direct-buried bond clamp to the service RMC below ground level, adjacent to the foundation. Bond the service conduit to the controller cabinet ground rod. Install a continuous nylon pull rope of at least 200 lbs (90 Kg) breaking strength in the conduit between the meter socket and the service source. Ensure all circuit breakers are off when service is connected by the utility company. The work must be inspected and approved by the Engineer or his designated representative prior to scheduling a service connection. Record the meter number and the date service is connected for billing purposes.

**Service Request**

Traffic Signal on State Road: Contact the CT DOT Traffic Electrical office to complete the necessary service request forms.

Traffic Signal on Town Road: Complete all necessary request forms and forward to the appropriate power company office.

Incident Management Site: Complete all necessary request forms and forward to the appropriate power company office.

Locations served by Connecticut Light and Power Co. and all other electric power providers  
Contact the power company engineering representative for exact requirements of the service. All riser fees and any other installation charges required of an underground metered service are the responsibility of the Contractor. When the work is complete notify the Engineer to inspect and confirm that the work is according to the National Electric Code. Request that the Engineer contact the power company to schedule the connection.

**Method of Measurement:**

The installation of the Service (Metered) will be measured for payment by the number of metered electric services of the type specified, completed, with service connected, and accepted in place.

**Basis of Payment:**

This work will be paid for at the contract unit price each for "Service (Metered)" complete and accepted in place. The price shall include all material above ground such as the meter socket enclosure, surface conduit, expansion fitting, coupling, and load side service conductors. The price shall also include the direct-buried ground clamp, bonding wire, pull rope, all material, equipment, tools, labor and incidentals necessary.

The power company will provide the line-side conductors and the meter.

**ITEM # 1102002A                      8' ALUMINUM PEDESTAL**

**Article 11.02.02 – Materials:** The materials for this work shall conform to the requirements of Article M.16.03.

**Article M.16.03 – Materials:**

Add the following paragraphs:

All exterior surfaces shall be coated with a Urethane or Triglycidyl Isocyanurate (TGIC) Polyester Powder to a minimum film thickness of 2.0 mils. The coating shall be electrostatically applied and cured in a gas fired convection oven by heating the steel substrate to a minimum of 350 degrees Fahrenheit and a maximum of 400 degrees Fahrenheit. The thermosetting powder resin shall provide both intercoat as well as substrate fusion adhesion that meets 5A or 5B classifications of ASTM D3359.

The color of the finish coat shall be **or Black, federal standard 595, Color No. 27038.**

The powder coating facilities shall be owned and operated by the pole manufacturer to ensure a quality coating system. Prior to shipment, small poles shall be wrapped in 0.19 inches thick Ultraviolet inhibiting plastic backed foam. Larger poles shall be cradled in a 12 inches rubberized foam base.

Any coating damaged prior to or during the installation of shall be repaired. Areas to be repaired shall be clean, dry, free from grease, oil, corrosion products and other contamination. If contaminated, power wash or scrub with stiff brush and clean water. Repair areas may be brushed or sprayed as appropriate. If the Contract elects to spray he must provide overspray containment. The minimum overspray containment shall conform to the requirements of SSPC Guide 6 for the Class 3A level.

**ITEM # 1104028A                      30' STEEL MAST ARM ASSEMBLY**

**ITEM # 1104031A                      35' STEEL MAST ARM ASSEMBLY**

**ITEM # 1104037A                      45' STEEL MAST ARM ASSEMBLY**

**Description:** Work under this item shall consist of designing, fabricating and installing a mast arm assembly to carry traffic appurtenances (such as traffic signals, signs, antenna, etc.) of the type specified, on a prepared foundation, in accordance with the details shown on the plans, in accordance with these specifications and as ordered by the Engineer.

Mast arms shall be painted black. The color of the finish coat for Mast Arms and anchor bolt covers, handhole covers, post caps and end caps shall be included under this item.

**Materials:** The structural plate components, such as the baseplate and the plates in the arm to pole ring stiffened, built-up box connection, shall be made of steel that conforms to the requirements, including the supplementary notch toughness requirements, of ASTM A709, Grade 50T2 (ASTM A709M, Grade 345T2) and meet the following Charpy-V Notch toughness requirements:

Minimum test value energy 20 ft.-lbs.  
Minimum average energy 25 ft.-lbs. at 40° F

The Charpy V-notch sampling and testing shall be in accordance with ASTM A673, "P" piece frequency.

The tubular components, such as the pole, arm and luminaire arm, and the steel for the handhole reinforcement, shall be made of steel with a minimum yield stress of 35,000 psi (241 MPa). The steel shall meet the following notch toughness requirements:

Yield Strength	Thickness in. (mm)	Minimum Test Value Energy ft.-lbs. (J)	Minimum Average Energy, ft.-lbf (J)
$F_y \leq 36 \text{ ksi (250 MPa)}$	$\leq 4 \text{ (100)}$	20	25 (34) at 40°F (4°C)
$36 \text{ ksi (250 MPa)} < F_y \leq 50 \text{ ksi (345 MPa)}$	$\leq 2 \text{ (50)}$	20	25 (34) at 40°F (4°C)
$36 \text{ ksi (250 MPa)} < F_y \leq 50 \text{ ksi (345 MPa)}$	$2 < t \leq 4$ $(50 < t \leq 100)$	24	30 (41) at 40°F (4°C)
$50 \text{ ksi (345 MPa)} < F_y \leq 70 \text{ ksi (485 MPa)}$	$\leq 4 \text{ (100)}$	28	35 (48) at -10°F (-23°C)

Charpy V-notch sampling and testing shall be in accordance with AASHTO T243 (ASTM A673/A673M), "P" piece frequency.

Charpy V-notch sampling and testing shall be in accordance with AASHTO T243 (ASTM A673/A673M), "P" piece frequency.

The non-structural components, such as hand hole covers, caps and anchor bolt covers, shall be made of steel with minimum yield strength of 36,000 psi (250 MPa).

All high strength bolts shall conform to ASTM A325, Type 1 (ASTM A325M, Type 1). Nuts shall conform to ASTM A563, Grade DH (ASTM A563M, Property Class 10S). Circular, flat, hardened steel washers shall conform to ASTM F436 (ASTM F436M). The bolts, nuts and washers shall be galvanized in accordance

with ASTM A153 (ASTM A153M) or ASTM B695, Grade 50. The nuts shall be overtapped to the minimum amount required for the bolt assembly and all surfaces of the nuts shall be lubricated with a lubricant containing a visible dye of any color that contrasts with the color of the galvanizing. The high strength bolts shall conform to the requirements of Subarticle M.06.02-3.

The anchor bolts shall conform to ASTM F1554, Grade 105. The nuts shall conform to ASTM A563, Grade DH (ASTM A563M, Class 10S). The washers shall conform to ASTM F436 (ASTM F436M). The bolts, nuts and washers shall be galvanized in accordance with ASTM A153 (ASTM A153M). The nuts shall be overtapped to the minimum amount required for the bolt assembly and all surfaces of the nuts shall be lubricated with a lubricant containing a visible dye of any color that contrasts with the color of the galvanizing.

All steel components, including anchor bolts, shall be completely hot-dip galvanized, after fabrication, in accordance with ASTM A123 (ASTM A123M) or ASTM A153 (ASTM A153M), as applicable. Repairs to damaged areas of the hot-dip galvanized coatings shall conform to the requirements of ASTM A780 amended as follows:

Paints containing zinc dust, if used for repairs, shall contain either between 65% to 69% metallic zinc by weight or greater than 92% metallic zinc by weight in dry film.

The silicone sealant shall be a 1-component, 100% silicone sealant recommended for use with galvanized steel.

Neoprene gasket material for the access openings shall conform to ASTM D1056, Grade 2A2 or 2A3. Other grades of neoprene approved by the Engineer may be used.

Closed cell elastomer for sealing the space between the foundation and base plate shall conform to ASTM D1056, Grade 2A2 or 2A3 and shall have a pressure-sensitive adhesive backing on one side for adhesion to steel. Closed cell elastomer contained within the anchor bolt pattern shall not interfere with the anchor bolt leveling nuts and shall not block the opening in the base plate.

Bare copper grounding conductor shall be #8 AWG stranded bare copper wire conforming to M.15.13. The grounding bolt shall be stainless steel with a hex head.

The Contractor shall submit Certified Test Reports and Materials Certificates in conformance with Article 1.06.07 for the steel used in the mast arm members and components, high-strength bolts (including nuts and washers) and anchor bolts (including nuts and washers). The Certified Test Reports shall include the following:

- a. Mill test reports that indicate the place where the material was melted and manufactured.
- b. High-strength bolt test results for proof load tests, wedge tests, and rotational-capacity tests that indicate where the tests were performed, date of tests, location of where the components were manufactured and lot numbers.
- c. Galvanized material test results that indicate the thickness of the galvanizing.

Prior to incorporation into the work, the Contractor shall submit samples in conformance with Article 1.06.02 for the steel used in the mast arm members and components, high-strength bolts (including nuts and washers) and anchor bolts (including nuts and washers).

**Construction Methods:** The design and fabrication of the mast arm assembly, including its anchorage (into the foundation), shall conform to the requirements of the latest edition of the AASHTO Standard Specifications for Structural Supports for Highway Signs, Luminaires and Traffic Signals, including the latest interim specifications, amended as follows:

- The design wind speed shall be 120 mph (193 km/hr). The computation of wind pressures in accordance with Appendix C is not permitted.
- The mast arms shall be designed to support fixed mounted traffic signals and signs. The wind drag coefficient for traffic signals and luminaires shall be 1.2.
- The mast arms shall be designed for fatigue category I. The mast arms shall be designed for the wind load effects due to galloping, natural wind gusts and truck-induced gusts. The luminaire arms shall be designed for the wind load effects due to natural wind gusts. The design pressure for the truck-induced gust shall be based on a truck speed of 65 mph (105 km/hr). The design of the mast arms assuming that vibration mitigation devices will not be installed.
- The vertical deflection of the free end of the arm due to the wind load effects of galloping and truck-induced gusts shall not exceed 8" (200 mm).
- The minimum design life for mast arms shall be 50 years.
- The maximum stress ratio (the ratio of the computed stress to the allowable stress) or combined stress ratio in any mast arm component due to each group load shall not exceed 0.90.
- The maximum arm length shall be 50'-0" (12 000 mm), measured from the centerline of the pole to the tip of the arm.
- The maximum luminaire arm length shall be 15'-0" (4500 mm).
- The maximum diameter of the pole at its base shall be 18" (457 mm).
- The maximum diameter of the arm at the arm-pole connection shall be 15" (381 mm).
- The minimum wall thickness of the arm at the pole connection and the pole shall be 5/16" (8 mm).
- The arm, luminaire arm and pole shall be fabricated from either round or multisided tubular members. Multisided tubular members with other than 8, 12 or 16 sides are not permitted. Multisided tubular members with fluted sides are not permitted. The arm and luminaire arm shall be fabricated with a taper (change in diameter).
- A maximum of one slip-type field splice is permitted in the arm. Slip-type field splices are not permitted in the pole. The wall thickness of the pole and arm component members shall be uniform throughout their lengths. The use of multiple plies (laminations) to obtain the required arm and pole thickness is not permitted. The use of shop-fabricated stepped members is not permitted.
- The arm, luminaire arm and pole members may be fabricated with no more than 2 longitudinal seam welds.

- The longitudinal seam welds within 6" (152 mm) of the member ends shall be complete joint penetration groove welds. The longitudinal seam welds on the female section of telescopic (slip-type) field splices shall be complete joint penetration groove welds for a length equal to the minimum splice plus 6" (150 mm).
- Partial joint penetration longitudinal seam welds shall be non-destructively tested in accordance with the magnetic particle method. Complete joint penetration longitudinal seam welds in members less than 5/16" (8 mm) thick shall be non-destructively tested in accordance with the magnetic particle method on both the inside and outside surfaces. Complete joint penetration seam welds in members greater than or equal to 5/16" (8 mm) thick shall be non-destructively tested in accordance with the ultrasonic method.
- The arm to transverse plate connection shall be made with a complete joint penetration groove weld with a backing ring attached to the plate with a continuous fillet weld. The pole to transverse base plate connection (at the foundation) shall be made with a complete joint penetration groove weld with a backing ring attached to the plate with a continuous fillet weld. 100% of the complete joint penetration groove welds shall be non-destructively tested by the ultrasonic method. After galvanizing, the joint between the backing ring and tubular member shall be sealed with silicone sealant.
- The strength of a connection made with a complete joint penetration groove weld shall be no greater than the strength of the base metal. In connections joining base metal with different yield strengths, the base metal with the lower yield strength shall govern the design.
- The minimum base plate and flange plate thickness shall be 2" (51 mm). The determination of the plate thickness in the tubular member to transverse plate connections shall consider the potential for the plate to warp due to the heat from welding. Consideration should be given to the use of thicker plates to allow for subsequent machining of warped plates to a flat surface so that removal of material will not compromise the required strength of the plate.
- The flange plate connection in the arm to pole in the ring stiffened, built-up box connection shall be designed as slip critical connections with standard holes. The minimum number of high-strength bolts in a flange splice shall be 8. Consideration should be given to the use of smaller diameter bolts since they require lower specified minimum bolt tensions.
- The minimum thickness of the ring plates and gusset plates in the ring stiffened, built-up box connection shall be 1/2" (12 mm).
- The size of fillet welds specified in designed connections shall be no less than 5/16". The use of seal and tack welds is not permitted. No welding shall be performed after galvanizing.
- The use of stiffeners at tubular member to transverse plate connections and at the arm to pole connection is not permitted.
- The pole base plate anchor bolt circle diameter shall be 24" (610 mm).
- The anchor bolt to base plate connection shall be designed as a double-nut connection with shear holes. The anchor bolts shall use embedded anchorage plates to transmit loads from the pole base to the concrete foundation. The use of hooked anchor bolts is



not permitted. The minimum number of anchor bolts shall be 8. The minimum anchor bolt diameter shall be 2" (51 mm). The minimum anchor bolt embedment, the distance from the top of the foundation to the top of the embedded anchorage plate, shall be 3'-6" (1067 mm). Each anchor bolt shall be supplied with 4 nuts and 4 washers. Washers shall be placed on the top and bottom surfaces of the pole base plate and anchorage plate. Welding to the anchor bolts is not permitted.

The mast arm shall be designed for the load effects due to the actual traffic appurtenances (signals, signs, luminaires, cameras, etc.). The mast arms shall also be designed for the effects of traffic appurtenances during all stages of construction that may exist during the project under which the mast arms are installed. The mast arms shall be designed to support traffic appurtenances with properties no less than those tabulated on the plans.

The dimensions of the mast arm assemblies are shown on the traffic plans, elevations, cross-sections or in the special provisions. The arm, luminaire arm and pole lengths and the attachment heights shall be verified by the Contractor based on the finished grade at the site, top of foundation elevation, the locations of overhead utility cables and the traffic appurtenance mounting heights. If either the arm or pole length is inadequate, the Contractor shall notify the Engineer.

The minimum vertical clearance from the top of the finished road to the bottom of the traffic signals shall be 16'-0" (4877 mm). The maximum vertical clearance from the top of the finished road to the bottom of the traffic signals shall be 18'-0" (5486 mm). The traffic signals shall be installed so that the bottom of all the signals for each approach is at the same elevation.

The arm to pole connection shall be made with a ring stiffened, built-up box. The luminaire arm to pole connection shall be made with either a built-up box or a ring stiffened built-up box. A minimum of 8 high-strength bolts shall be used to connect the arm flange plate to the built-up box connection plate. A minimum of 4 high-strength bolts shall be used to connect the luminaire arm flange plate to the built-up box connection plate. All fasteners and their components used in the connection shall be visible. The use of tapped holes in the plates of the connection is not permitted. A hole(s) shall be provided in the connection to allow wires to pass from the pole to the arm and luminaire arm. The sides of all other holes in the connection shall be ground smooth and the edges rounded by grinding to prevent the wires from chafing. Holes placed in the connection for galvanizing shall be filled with neoprene plugs.

A J-hook shall be welded to the inside of the pole at the top for wire handling and support.

The mast arm pole shall have a handhole centered 1'-3" (380 mm) from the top of the base plate. The handhole shall be located away from traffic. The handhole shall be reinforced with a frame having a minimum 4" (102 mm) wide by minimum 6" (152 mm) high clear opening. The minimum thickness of the handhole frame shall be no less than the thickness of the pole. The handhole frame shall be connected to the pole with a partial joint penetration groove weld reinforced with a fillet weld. The handhole shall be provided with a cover connected to the frame with stainless steel screws. The cover shall be installed with a neoprene gasket matching the dimensions of the cover. The cover shall also be attached to the frame with a stainless steel chain. The inside bottom of the frame shall have a hole tapped for the stainless steel grounding bolt.

The mast arm shall be supplied with a pole cap plate, arm cap plate, and anchor bolt covers. The cap plates shall be attached with fasteners. The joint between the tubular member and plate shall be sealed with a neoprene gasket matching the dimensions of the plate.

Prior to fabrication, the Contractor shall submit working drawings and design computations for each mast arm assembly to the Engineer for review in accordance with Article 1.05.02. An individual, independently packaged set of working drawings and computations, with all details and documents necessary for

fabrication and erection of the structure and its components, including a copy of the certificate of insurance, shall be prepared and submitted for **each** mast arm. **A single set of drawings with tabulated data for multiple mast arm locations is not permitted.** The alpha-numeric mast arm identifier shall be included on these documents. The working drawings and computations shall be prepared in Customary U.S. units.

The packaged set of working drawings and computations for each mast arm assembly shall be submitted either in paper (hard copy) form or in an electronic portable document format (.pdf) with appropriate bookmarks. The packaged set submitted in paper form shall be bound with a staple. The packaged set submitted in an electronic portable document format (.pdf) shall be in an individual file and the file shall be enabled for commenting. The packaged set shall include the following:

- title sheet
- table of contents
- contact information for designer, fabricator and galvanizer – contact information should include name and address of each firm and the name of contact person with phone number and email address
- copy of the certificate of insurance
- copy of fabricator's AISC certification
- copy of the traffic signal control plan detailing mast arm assembly
- mast arm assembly working drawings
- mast arm assembly design computations
- welding procedures
- mast arm installation procedure, including the method to plumb the pole

The working drawings and design computations shall be **signed, dated and sealed** by a Professional Engineer licensed in the State of Connecticut, who shall also be available for consultation in interpreting his computations and drawings, and in the resolution of any problems which may occur during the performance of the work. Each working drawing shall be signed, dated and sealed. The cover/first sheet for the computations shall be signed, dated and sealed.

Working drawings submitted in paper form shall be printed on ANSI B (11" x 17"; 279 mm x 432 mm; Ledger/Tabloid) sheets. Each drawing shall have a border and title block. Located in the lower right hand corner of the drawing adjacent to the title block, each drawing shall have a rectangular box, 2 1/4" wide x 1 3/4" high (57 mm wide x 44 mm high), for the reviewers stamp. On the ANSI B sheets, the minimum text height and width shall be 1/16". All letter characters shall be uppercase. Design computations, procedures and other supporting data shall be submitted on 8 1/2" x 11" (216 mm x 279 mm) (Letter) sheets.

Working drawings submitted in an electronic portable document format (.pdf) shall be created on ANSI D (22" x 34"; 559 mm x 864 mm) full scale (1" electronic file = 1" paper) sheets. (The purpose of creating the drawings on ANSI D sheets is so that the sheets may be printed/plotted at that size or smaller without loss of legibility.) Each drawing shall have a border and title block. Located in the lower right hand corner of the drawing adjacent to the title block, each drawing shall have a rectangular box, 2 1/4" wide x 1 3/4" high (57 mm wide x 44 mm high), for the reviewers stamp. On the ANSI D full scale sheets, the minimum text height and width shall be 1/8". All letter characters shall be uppercase. The electronic files for the design computations, procedures and other supporting data shall be created on ANSI A (8 1/2" x 11", 216 mm x 279 mm) letter sheets.

The working drawings shall include complete details of all mast arm components. The drawings shall include, but not be limited to the following:

- the project number, town and mast arm identification number

- reference to the design specifications, including interim specifications
- reference to the design specifications design criteria, such as design wind speed, minimum design life, fatigue category, vehicle speed, etc.
- material specifications for all components
- material designations for the arm and pole, with an explanation of the alpha numeric characters (equivalent thickness, in inches (in millimeters), shall be provided for gage numbers)
- non-destructive weld testing requirements
- details of the location of the longitudinal seam welds in the arm, luminaire arm and pole
- a plan view of the anchor bolt layout relative to the orientation of the arm(s)
- anchor bolt dimensions, including embedment and projection
- permanent camber
- mast arm installation procedure, including the method to plumb the pole

The design computations shall include, but not be limited to the following:

- the project number, town and alpha-numeric mast arm identifier
- computations for projects in Customary U.S. units shall be provided in Customary U.S. units. Computations for projects in metric units shall be provided in both Customary U.S. units and metric units.
- references to design specifications, including interim specifications, and the applicable code section and articles
- description/documentation for all computer programs used in the design
- drawings/models of the structure, components and connections, with dimensions, loads and references to the local and global coordinate systems used (as applicable), to facilitate review of the results
- a tabulation of the section properties of the tubular members at each analyzed section. The tabulated values should include the diameter,  $D$  (if round member); effective width,  $b$  (if multisided member, AASHTO 5.5.2); equivalent diameter (if multisided member, AASHTO 5.6), wall thickness,  $t$ ; inside bend radius,  $r_b$  (if multisided member, AASHTO 5.5.2), cross-sectional area,  $A$ ; moment of inertia,  $I$ ; section modulus,  $S$ ; radius of gyration,  $r$ . AASHTO Table B-1 may be used to determine the section properties. If Table B-1 is used, the radius measured to the mid-thickness of the wall shall also be provided.
- results of all group loads and load combinations
- stress ratios and combined stress ratios for all group loads and load combinations

- maximum vertical deflection due to dead loads
- vertical deflection of the free end of the arm due to the wind load effects of galloping and truck-induced gusts

The Contractor shall submit the packaged set of working drawings and calculations to the “Engineer of Record”. The “Engineer of Record” is identified in the signature block on the mast arm assembly contract plans. A copy of the transmittal shall be sent to the District Construction office administering the project.

Fuss & O’Neill is the “Engineer of Record” and the working drawings and calculations shall be submitted to the following person and address:

Mr. Mark G. Vertucci, PE, PTOE  
Senior Project Manager  
Fuss & O’Neill  
146 Hartford Road  
Manchester, CT 06040  
[mvertucci@fando.com](mailto:mvertucci@fando.com)

The reviewed and stamped working drawings and calculations shall be sent by the reviewer, along with a recommendation regarding acceptance, to the District Construction office for review, comment and distribution. After the District Construction office has reviewed the working drawings and calculations, ensured all comments have been addressed and have found the submittal to be acceptable, in addition to distributing copies of the working drawings and calculations to the Contractor and District offices, a copy of each packaged set of working drawings and calculations shall be sent to the following Department offices:

Bridge Safety and Evaluation - Robert P. Zaffetti – Sandra A. Dumas  
Research and Materials - Ravi V. Chandran - Robert G. Lauzon  
Traffic Engineering - John F. Carey - Tracy L. Fogarty  
Traffic Signal Lab - James F. Nesci  
Engineer of Record

The mast arm assemblies shall be fabricated in accordance with the latest edition of the AASHTO LRFD Bridge Construction Specifications, including the latest interim specifications, amended herein.

The steel fabricator shall be AISC certified for the fabrication of Simple Steel Bridges (SBR).

Fabrication of the mast arm may begin only after the working drawings and design computations have been reviewed and the Engineer has authorized fabrication to begin. The Contractor shall submit to the Engineer, no less than 2 weeks prior to the start of fabrication, the name and location of the fabrication shop where the work will be done so that arrangements can be made for an audit of the facility and the assignment of the Department Quality Assurance (QA) inspector. No fabrication will be accepted unless the QA inspector is present during fabrication. No changes may be made during fabrication without prior written approval by the Department.

The Contractor shall furnish facilities for the inspection of material and workmanship in the shop by the Engineer. The Engineer and his representative shall be allowed free access to the necessary parts of the premises.

The Engineer will provide QA inspection at the fabrication shop to assure that all applicable Quality Control plans and inspections are adequately adhered to and maintained by the Contractor during all phases of the fabrication. A thorough inspection of a random selection of elements at the fabrication shop may serve as the basis of this assurance.

Prior to shipment to the project, each individual piece of structural steel shall be marked in a clear and permanent fashion by a representative of the fabricators' Quality Control (QC) Department to indicate complete final inspection by the fabricator and conformance to the project specifications for that piece. The mark must be dated. A Materials Certificate in accordance with Article 1.06.07 may be used in lieu of individual stamps or markings, for all material in a single shipment. The Materials Certificate must list each piece within the shipment and accompany the shipment to the project site.

Following the final inspection by the fabricator's QC personnel, the Engineer may select pieces of structural steel for re-inspection by the Department's QA inspector. Should non-conforming pieces be identified, all similar pieces must be re-inspected by the fabricator and repair procedure(s) submitted to the Engineer for approval. Repairs will be made at the Contractor's expense.

The pieces selected for re-inspection and found to be in conformance, or adequately repaired pieces, may be marked by the QA inspector. Such markings indicate the Engineer takes no exception to the pieces being sent to the project site. Such marking does not indicate acceptance or approval of the material by the Engineer.

Fabrication of the mast arm assemblies shall conform to the requirements of Articles 6.03.04, 6.03.05, 6.03.06 and 6.03.10, 6.03.11, 6.03.12 and 6.03.13.

All welding details, procedures and nondestructive testing shall conform to the requirements of AWS D1.1 Structural Welding Code - Steel.

Personnel performing the nondestructive testing shall be certified as a NDT Level II technician in accordance with the American Society for Non Destructive Testing (ASNT), Recommended Practice SNT-TC-1A and approved by the Engineer.

All nondestructive testing shall be witnessed by Engineer. Certified reports of all tests shall be submitted to the Engineer for examination. Each certified report shall identify the structure, member, and location of weld or welds tested. Each report shall also list the length and location of any defective welds and include information on the corrective action taken and results of all retests of repaired welds.

The Department reserves the right to perform additional testing as determined by the Engineer. Should the Engineer require nondestructive testing on welds not designated in the contract, the cost of such inspection shall be borne by the Contractor if the testing indicates that any weld(s) are defective. If the testing indicates the weld(s) to be satisfactory, the actual cost of such inspection will be paid by the Department.

All members and components shall be hot-dip galvanized in a single dip. Double-dipping shall not be used.

All damaged areas of the hot-dip galvanized surfaces shall be repaired in accordance with the requirements of ASTM A780. If paint containing zinc dust is used for repairs, the dry coating thickness shall be at least 50% greater than the thickness of the adjacent hot-dip galvanized coating, but no greater than 4.0 mils. The paint shall be brush applied. The use of aerosol spray cans shall not be permitted. The color of the finished repair area shall match the color of the adjacent hot-dip galvanized surface at the time of the repair to the satisfaction of the Engineer.

After fabrication, the arm to pole bolted connection shall be assembled in the fabricator's shop, in the presence of the Engineer, to determine the acceptability of the connection. The faying surfaces shall be free of dirt, loose scale, burrs, other foreign material and other defects that would prevent solid seating of the parts. Prior to assembly, the galvanized faying surfaces shall be scored by wire brushing. The faying surfaces of the connection plates shall be checked with a straight edge to ensure that the surfaces are not distorted and the entire faying surface of each plate will be in contact when assembled. The high-strength bolts, including nuts and washes, shall be installed and tensioned in accordance with Subarticle 6.03.03-4(f).

A connection may be found acceptable by the Engineer if the faying surfaces of the flange (connection) plates are in firm, continuous contact after properly tensioning the bolts. Only mast arm assemblies with acceptable arm to pole bolted connections shall be shipped. If a bolted connection is found not acceptable, the Contractor shall submit a procedure to repair the connection to the Engineer for review. Galvanized surfaces damaged by the repair procedure shall be hot dip galvanized. Repair of the damaged galvanized surfaces in accordance with the requirements of ASTM A780 or with a galvanizing repair stick is not permitted. Bolts, nuts and washers used for the trial shop fit-up shall not be reused in the final field assembly.

After fabrication and prior to shipping, aluminum identification tags shall be attached to the arm and pole members with self-tapping tamper resistant screws.

The finished members and components shall be protected with sufficient dunnage and padding to protect them from damage and distortion during transportation. Damage to any material during transportation, improper storage, faulty erection, or undocumented fabrication errors may be cause for rejection of said material at the project site. All costs associated with any corrective action will be borne by the Contractor.

Following delivery to the project site, the Engineer will perform a visual inspection of all material to verify shipping documents, fabricator markings, and that there was no damage to the material or coatings during transportation and handling.

The Engineer is not responsible for approving or accepting any fabricated materials prior to final erection and assembly at the project site.

High-strength bolts, nuts and washers shall be stored in accordance with Subarticle 6.03.03-4(f).

The mast arm shall be erected, assembled and installed in accordance with these specifications and the procedures and methods submitted with the working drawings. The Contractor and the mast arm designer are responsible to ensure that the erection and assembly procedures and methods in this specification are acceptable for use with the mast arm assembly. Changes to these method and procedures shall be submitted with the working drawings and computations.

Prior to installation of the mast arm pole, the threads of the embedded anchor bolts shall be cleaned of accumulated dirt and concrete. The anchor bolt nuts shall be re-lubricated with a lubricant containing a visible dye of any color that contrasts with the color of the galvanizing. On each anchor bolt, all the nuts shall be run down by hand on the anchor bolt threads.

The pole shall be erected so that the centerline of the pole will be plumb after the application of all the dead loads. The pole may be initially installed raked in the opposite direction of the overhead member to obtain the plumb condition.

During the erection of the pole, the leveling nuts and washers shall be inspected, and if necessary adjusted, so that they are in full contact with the bottom surface of the baseplate. Subsequently, the top nuts and washers shall be inspected, and if necessary adjusted, so that they are snug tight (in full contact with the baseplate). Snug tight is defined as the condition where the nuts and washers are in full contact with the baseplate and the snug tight condition was the result of the full effort of a person using a 12" wrench.

With the top nuts snug tight, the top nuts shall be tightened one-sixth of a turn beyond snug tight. After the top nuts are tightened, the leveling nuts should be retightened to assure the full contact has been maintained. The top nuts shall have full thread engagement. The distance from the bottom of the leveling nuts to the top of the foundation shall not exceed 1" (25 mm).

High-strength bolts, including nuts and washes, shall be installed and tensioned in accordance with Subarticle 6.03.03-4(f). The arm shall be temporarily and fully supported while all the high-strength bolts are installed and tensioned. The temporary arm support shall not be removed until the Engineer has confirmed that the faying surfaces of the flange (connection) plates are in firm, continuous contact and the high-strength bolts were properly installed and tensioned. All high-strength bolts in the arm to pole bolted connection shall be inspected (in accordance with Subarticle 6.03.03-4(f)) to confirm the high-strength bolts were properly tensioned.

After erecting the mast arm, the mast arm shall be electrically grounded by attaching the bare copper grounding conductor to the inside of the handhole frame with a stainless steel bolt and to the ground rod with a ground clamp. The rigid metal conduit shall be electrically grounded by attaching the bare copper grounding conductor to the insulated bonding bushing and to the ground rod with a ground clamp.

The traffic appurtenances shall be located and mounted on the arm as shown on the cross-sections. Holes, if required for wires, shall be located adjacent to the appurtenances and shall be drilled in the bottom of the arm. A rubber grommet shall be installed in each hole to protect the wires from chafing.

After installation of the traffic appurtenances, the anchor bolt nuts (leveling and top anchor nut) and washers shall be in full contact with the top and bottom surfaces of the pole base plate and the centerline of the pole shall be plumb.

After installation of the traffic appurtenances, if the structure exhibits excessive vibration, oscillations or deflections as determined by the Engineer, the Contractor shall design and construct devices to mitigate the movements. The Contractor is responsible for immediately stabilizing the structure to the satisfaction of the Engineer. Stabilizing the structure may require the removal of the sign panels or the entire structure. Prior to installation of any mitigation device, the Contractor shall submit drawings, design computations other documentation to the Engineer for review in accordance with Article 1.05.02.

The last character of the mast arm identification number shall be stenciled with black paint, unless otherwise specified, on the pole of each mast arm. The character shall be 3" (76 mm) high and placed approximately 1' (305 mm) above the top of the base plate facing the centerline of the roadway.

All exterior surfaces shall be coated with a Urethane or Triglycidyl Isocyanurate (TGIC) Polyester Powder to a minimum film thickness of 2.0 mils (0.0508 mm). The coating shall be electrostatically applied and cured in a gas fired convection oven by heating the steel substrate to a minimum of 177 degrees Celsius (350 degrees Fahrenheit) and a maximum of 204 degrees Celsius (400 degrees Fahrenheit). The thermosetting powder resin shall provide both intercoat as well as substrate fusion adhesion that meets 5A or 5B classifications of ASTM D3359.

The color of the finish coat for steel mast arms, anchor bolt covers, handhole covers, post caps, and end caps shall be black. **The color of the finished coat shall be BLACK**, No. 17038, Federal Standard No. 595.

**Method of Measurement:** This work will be measured for payment by the number of steel mast arm assemblies of the type specified, completed and accepted in place.

**Basis of Payment:** This work will be paid for at the contract unit price each for "XX Steel Mast Arm Assembly" of the type specified, complete in place, which price shall include all equipment, materials, tools and labor incidental to the design, fabrication and installation, including mitigation devices if required, of the mast arms at the locations specified on the plans.

**ITEM # 1105101A                      1 WAY, 1 SECTION MAST ARM TRAFFIC SIGNAL**

**ITEM # 1105103A                      1 WAY, 3 SECTION MAST ARM TRAFFIC SIGNAL**

**Article 11.05.03 – Construction Methods:**

Add the following paragraph:

Circular indications that have an identification mark (such as an arrow) on the top of the lens shall be installed with that mark at the 12 o'clock position.

**Article M.16.06 - Traffic Signals**

**Sub Article 3 - Housing:**

In the last sentence, between the words "housing" and "shall" add "and all internal hardware".

Add the following after the last paragraph.

Each section of the housing shall be provided with a removable visor. The visor shall be the cap type, unless otherwise noted on the plan. The visor shall be a minimum .05 inch (.13 mm) thick. The visor shall be the twist on type and secured to the signal by four equidistant flat tabs screwed to the signal head.

**Sub Article 4 - Brackets:**

Add the following at the end of the last paragraph:

Install a 2" wide yellow retroreflective strip (Type IV sheeting) along the perimeter of the face of the backplate.

**Delete Sub Article 5 - Optical Unit and Sub Article 6 – Lamp Socket and replace with the following:**

Optical Unit, Light Emitting Diode:

**(a) General:**

Only Optical Units that meet the requirements contained herein supplied by the below manufacturers that have been tested by the Department's Signal Lab will be accepted. Final approval for model numbers will be done at the time of the catalog cut submittals.

Duralight  
Trastar, Inc.  
860 N. Dorothy Dr., Suite 600  
Richardson, TX 75081

GE Lighting Solutions  
Corporate Headquarters  
1975 Noble Road Building 338E  
East Cleveland, OH 44112-6300

Dialight  
1501 Foute 34 South  
Farmingdale, NJ 07727

Leotek  
726 South Hillview Drive  
Milpitas, CA 95035

The materials for Light Emitting Diode (LED), Optical Unit, circular and arrow, shall conform to the following:  
The ITE Performance Specification for Vehicle Traffic Control Signal Heads – Light Emitting Diode (LED)  
Circular Signal Supplement for circular indications dated June 27, 2005.  
The ITE Performance Specification for Vehicle Traffic Control Signal Heads – Light Emitting Diode (LED)  
Vehicle Arrow Traffic Signal Supplement for arrow indications dated July 1, 2007.

Section 4, Adjustable Traffic Signals and General Housing sections of the **Department of Transportation Functional Specifications for Traffic Control Equipment, 2012-2015**. Where the Department of Transportation Functional Specifications conflict with this Special Provision or the 2005/2007 ITE Performance Specifications, this Special Provision and the 2005/2007 ITE Performance Specifications shall govern.



The Optical Unit shall have an Incandescent look and be made up of a smooth surfaced outer shell, multiple LED light sources, a filtered power supply and a back cover, assembled into a sealed unit. The Optical Unit shall be certified as meeting the 2005/2007 ITE Specifications by Intertek Testing Services, Inc. (ITSNA, formerly ETL) or another organization currently recognized by the Occupational Safety and Health Administration (OSHA) as a Nationally Recognized Testing Laboratory (NRTL.) The Optical Unit shall perform to the requirements of the ITE Specification for a minimum of 60 months.

A "Swing Test" will be performed by the Department to ensure no significant dimming or blanking occurs, until the lamp is obscured by the visor. All L.E.D Lamps will be subjected to further field testing for reliable operation.

The Arrow Optical Unit shall be "Omni-Directional" so that it may be oriented in a right, left or straight configuration without degradation of performance.

(b) Electrical Requirement:

Operating voltage:

80 to 135 Volts AC with cutoff voltage (no visible indication) below 35Volts AC.

Power requirements:

Circular Indications: 12", (300 mm) – no more than 16 Watts

Circular Indications: 8", (200mm) - no more than 16 Watts

Arrows Indications: 12", (300mm) - no more than 16 Watts

Power Supply:

Fused and filtered to provide excess current protection and over voltage protection from electrical surges and transient voltages.

(c) Photometric Requirement:

Beam Color:

Meet 2005/2007 ITE Specifications

(d) Mechanical Requirements:

Diameter:

The Circular Optical Unit shall fit into standard 12" (300mm) or 8" (200mm) housing.

The Arrow Optical Unit shall fit 12" (300mm) housings only.

Enclosure:

UV (Ultraviolet) stabilized polycarbonate back cover.

Clear lens cover for all Red, Yellow and Green Circular Optical Units.

For Arrow Optical Units the arrow indication segment of the lens shall be clear.

Enclosure sealed and waterproofed to eliminate dirt contamination and be suitable for installation in all weather conditions.

Clearly mark on the housing the following information:

Manufacturer & model number

Date of manufacture (must be within one year of installation)

The model number shall end with the number of LEDs used to comprise the unit as the last digits of the model number. Example, if the unit comprised of 3 LEDs and the model is x12y, then the new model number shall read x12y3.

Operating temperature:

Meet 2005/2007 ITE Specification

**Wiring:** L.E.D. lamps shall have **color coded 16 AWG wires** for identification of heads as follows:

RED L.E.D. Lamps	RED with WHITE neutral
YELLOW L.E.D. Lamps	YELLOW with WHITE neutral
GREEN L.E.D. Lamps	GREEN or Brown with WHITE neutral
RED L.E.D. ARROWS	RED/WHITE with WHITE neutral
YELLOW L.E.D. ARROWS	YELLOW/WHITE with WHITE neutral
GREEN L.E.D. ARROWS	GREEN/WHITE or BROWN/WHITE with WHITE neutral
GREEN/YELLOW LE.D ARROWS	GREEN/WHITE or BROWN/WHITE, YELLOW/WHITE, with WHITE neutral

Wires shall be terminated with a Block Spade, 6-8 stud/ 16-14 wire size.

All Circular Optical Units shall be supplied with a minimum 40" pigtail and all Arrow Optical Units Supplied with a minimum 60" pigtail.

Sub Article 9 - **Painting:**

**Third coat:** Replace the first two sentences with the following:

All heads, brackets, and hardware shall be painted black by the manufacturer. The final coat shall be Gloss black powder coat finish according to Federal Standard No. 595 or approved equivalent.

**ITEM # 1106001A 1 WAY PEDESTRIAN SIGNAL POLE MOUNTED**

**ITEM # 1106003A 1 WAY PEDESTRIAN SIGNAL PEDESTAL MOUNTED**

**Section 11.06.02 Pedestrian Signal, Materials**

Section M.16.07 C. Optical Unit

Delete 2. LED: and replace with the following:

**General**

Meet requirements of current MUTCD Section 4E.

Meet current ITE specifications for Pedestrian Traffic Control Signal Indications - (PTCSI) Part 2: Light Emitting Diode (LED).

Meet CT DOT, 2008 - 2010 Functional Specifications for Traffic Control Equipment; Section 5D, LED Pedestrian Signal with Countdown Timer.

Meet EPA Energy Star® requirements for LED Pedestrian Signal Modules.

**Operational**

Countdown display only during the flashing Pedestrian Clearance (Ped Clr) Interval. Timer goes blank at end of flashing ped clr even if countdown has not reached zero.

**Physical**

Sealed optical module to prevent entrance of moisture and dust.

Self-contained optical module, including necessary power supplies.

Designed to securely fit into standard housing without the use of special tools or modifications to the housing.

Identification information on module: manufacturer's name, model number, serial number, and date code.

**Optical**

Multiple LED sources; capable of partial loss of LED's without loss of symbol or countdown message.

Two complete self contained optical systems. One to display the walking person symbol (walk) and the hand symbol (don't walk). One to display the countdown timer digits.

Visual Image similar to incandescent display; smooth, non-pixelated.

Symbol and countdown digit size as shown on the plan.

Solid hand/person symbol; outline display not allowed.

Overlaid hand/person symbols and countdown digits arranged side by side.

Countdown digit display color: Portland Orange in accordance with ITE requirements.

Countdown digits comprised of two seven segments, each in a figure 8 pattern.

Photometric Requirements: Luminance, Uniformity, and Distribution in accordance with ITE requirements.

Color Uniformity in accordance with ITE requirements.

Blank-Out design; symbols and digits illegible even in direct sunlight when not illuminated.

**ITEM # 1107011A ACCESSIBLE PEDESTRIAN SIGNAL & DETECTOR (TYPE A)**

**Description:**

Furnish and install an Accessible Pedestrian Signal and Detector (APS&D). The APS&D provides audio and tactile information to augment the visual pedestrian signal.

Type A provides a low frequency percussive tone during the walk interval and is used where there is an exclusive pedestrian phase or  $\geq 10$  foot separation between APS&Ds.

**Materials:**

A. General:

- Conform to applicable sections of the current MUTCD Chapter 4E, Pedestrian Control Features as specified herein.
- All features fully operational when the traffic signal is in colors mode.
- All features non-operational when the traffic signal is in flash mode.
- Interchangeable with a non-accessible type pedestrian pushbutton with no modifications to the Controller Assembly (CA) or Controller Unit.
- Audible transducer integral with the APS&D housing, adjacent to the pushbutton.
- Operation programming method: Either or combination of:
  - Mechanically by dip switches or circuit board jumpers
  - Infrared remote-control hand-held device

B. Electrical:

- Metallic components either grounded or insulated to preclude an electrical hazard to pedestrians under all weather conditions.
- All features powered by the 110VAC Walk signal and the 110VAC Don't Walk signal so that additional conductors from the CA are not needed.

C. Call Confirmation Light

- LED
- Color: Red
- Visible from the side a minimum 45 degrees from perpendicular to face of sign.
- Operation:
  - Off during walk interval
  - Off all other times until actuation of pushbutton.
  - Actuation of pushbutton latches the light ON until beginning of walk interval.
  - Actuation of pushbutton initiates speech message "Wait".
- Located directly adjacent to the pushbutton.

D. Audible Pushbutton Locator Tone

- Frequency: repeating tone at one (1) second intervals
- Tone duration:  $\leq 0.15$  seconds
- Volume:
  - Minimum setting of zero
  - Manually adjustable initial setting
  - Automatically adjusted after initial setting. Volume increased in response to a temporary increase in ambient noise and subsequently decreased with a decrease in ambient noise.
  - Maximum volume: 100 dBA which is the approximate sound pressure of a gasoline powered lawn mower nearby.
  - Automatic volume adjustment independent of other APS&Ds at the intersection.
  - May be disabled without affecting operation of other features.

- Silent only during walk interval. Active all other times.

E. Vibrotactile Arrow Pushbutton

- Pushbutton contained in a circular assembly which fits inside the housing and is attached to the housing with 4 screws.
- ADA compliant: Size:  $\geq 2.0$ " (50) diameter, Actuation force:  $\leq 5$  ft-lb (22.2 N)
- Shape: Circular, raised slightly above housing so that it may be actuated with the back of a hand
- Tamper-proof, vandal-proof, weatherproof, freeze-proof, impact-resistant design and construction.
- Operation: Vibrates only during the walk interval (when the walk indication is displayed).
- Tactile Arrow:
  - Attached to surface of the button assembly by a tamperproof method.
  - Raised slightly above surface of pushbutton, minimum 0.125" (0.3)
  - Size: Length  $\geq 1.5$ " (38), Height  $\geq 1.0$ " (25)
  - Color: Sharp contrast to background color of pushbutton and housing

F. Audible Walk Interval

1. General:

- Operation independent of other APS&Ds at intersection.
- Active only during the walk interval (when the walk indication is displayed).
- Volume:
  - Minimum setting of zero
  - Manually adjustable initial setting
  - Automatically adjusted after initial setting. Volume increased in response to a temporary increase in ambient noise and subsequently decreased with a decrease in ambient noise.
  - Automatic volume adjustment independent of other APS&Ds at the intersection.
  - Maximum volume: 100 dBA which is the approximate sound pressure of a gasoline powered lawn mower nearby.
- Duration:
  - Default method: Automatically set by the duration of the visual walk signal display.
  - When selected: Manually set when rest-in-walk is used for a concurrent pedestrian movement.
- Audible sounds that mimic any bird call are not allowed.

2. Type A, Percussive Tone:

- Repeating tone at eight (8) to ten (10) ticks per second.
- Tone frequency: Multiple frequencies with a dominant component at 880 Hz which creates a "tick - tick - tick..." sound.

G. Pushbutton Housing/Sign Frame/Sign

- One piece die cast aluminum meeting requirements of ASTM B85.
- Sign frame designed to accept 9" x 12" (230 x 300) four-hole advisory sign.
- Flat back to facilitate surface mount.
- Available brackets to either pedestal top-mount or pole side-mount on pole diameter range of 3½" (89) to 15" (380).
- Available brackets to allow mounting two (2) APS&Ds to the same 3½" (89) pole, facing  $\geq 60$  degrees apart, at the same height.
- Wire entrance through the rear.
- Stainless steel mounting hardware.
- Color: Dark Green, Federal No 14056, Federal standard No. 595
- Finish: Housing/Frame and all mounting brackets either:
  1. Painted with 3 coats of infrared oven-baked paint before assembly.
    - Primer: Baked iron oxide which meets or exceeds FS TT-P-636.

- Second coat: Exterior-baking enamel, light gray, which meets or exceeds FS TT-E-527.
- Third coat: Exterior-baking enamel, which meets or exceeds FS TT-E-489.
- 2. Electrostatic powder coated after chemically cleaned.
- Sign: CT DOT Sign No. 31-0845

**Construction Methods:**

Install the APS&D according to the manufacturer's instructions. Position the ASP&D so the plane of the sign face is parallel to the crossing (sign is facing perpendicular) and the arrow is pointing in the same direction as the crossing, not necessarily at the ramp. Notify the Engineer if there is any discrepancy or ambiguity between the plans and field conditions that prevent placement of the ASP&D as shown on the plan. Set the minimum sound levels of the locator tone and the audible walk indication when there is little or no ambient noise as in night time operation. Set the volume of audible walk indications and pushbutton locator tones to a maximum of 5dBA louder than ambient sound. The locator tone should be audible 6' to 12' (1.8 m to 3.6 m) from the pushbutton or to the building line, whichever is less. Confirm the volume of both audible walk indication and the locator tone increases with an increase in ambient sound and subsequently decreases when the ambient noise decreases.

If programming method is remote, by an infrared hand-held device, provide one device and operation manual for each intersection where APS&D is installed.

**Method of Measurement:**

This work is measured by the number of Accessible Pedestrian Signal and Detectors of the type specified, installed, tested, fully operational, and accepted.

**Basis of Payment:**

Payment for this work is based on the installation, inspection, successful completion of the 30 day test period, and final acceptance of the Accessible Pedestrian Signal and Detector of the type specified. Payment includes the sign, mounting brackets for adjacent buttons on the same structure, all incidental materials, labor, tools, and equipment necessary to complete the installation. Payment also includes the warrantee, installation manual, and operation manual.

If programming method is remote by an infrared hand-held device, the total bid price of all APS&Ds includes one remote programming device and accompanying operation manual for each intersection where APS&D is installed.

**ITEM #1108115A                      FULL ACTUATED CONTROLLER 8 PHASE**

**Article 11.08.01** - Description: Delete the second paragraph and replace with the following:

This item shall consist of furnishing and installing an actuated controller, which shall be a completely digital solid state unit, for controlling the operation of the traffic signals.

The controller shall be completely furnished with the number of phases called for in the item. The cabinet to house the controller shall be completely wired and all sub-bases shall be complete with load switches and flash relays as specified in the **Functional Specifications For Traffic Control Equipment**. The cabinet shall also have all necessary auxiliary equipment required to provide the sequence and timing indicated on the plans. A time switch shall be installed in each cabinet.

This item shall also include provisions for an uninterruptible power supply, transfer switch and external power supply connection for portable generator hookup in extended periods of area-wide loss of power. The UPS is specified under ITEM #1113812 herein.

**Article M.16.09** - Controllers: Add the following paragraph at the end of sub-article: Cabinet:

The Cabinet ventilation shall include two intakes, exhaust, filtration, two fan assembly and environmental controls. Each electric fan shall be equipped with ball or roller bearings and with a capacity of at least 100 cfm. The fan shall be mounted with the housing and be vented. Fans shall be installed in the front and back of the controller.

All exterior surfaces shall be painted with 3 coats of infrared oven-baked paint before assembly:

- Primer: Baked iron oxide which meets or exceeds FS TT-P-636.
- Second coat: Exterior-baking enamel, light gray, which meets or exceeds FS TT-E-527.
- Third coat: Exterior-baking enamel, which meets or exceeds FS TT-E-489.

All exterior surfaces shall be electrostatic powder coated after chemically cleaned.

- Color: Gloss Black, Federal No 27038, Federal standard No. 595.

**Article M.16.09** - Controllers: Add the following sub-articles:

2. Actuated Controllers: The purpose of this sub-article is to set forth minimum design and operating requirements for the materials and components for a digitally timed actuated controller.

**Controller Unit**

This Specification is for establishing the minimum requirements for a TS2 Actuated Traffic Signal Controller. The TS2 Actuated Traffic Signal Controller shall meet all of the applicable portions of the NEMA TS2 Type 1, 2003 Section 3 for Actuated Control, using the Naztex 980 controller or approved equal. "Approved equal" equipment shall be permitted only when written approval is obtained from the Town. If there is a discrepancy between this specification and NEMA requirements, the conditions of this specification shall prevail.

All controller types shall be sixteen (16) phase. A comprehensive technical document including functional description and drawings, both hardcopy and electronic, shall be attached to the Contractor's Bid. Failure to comply may result in the Bid being rejected.

***Controller Unit - General Functional Requirements***

The controller unit shall be:

- Fully actuated;
- Solid state microprocessor based;
- Menu driven;
- With capacity to control 16 traffic phases plus pedestrian phases; and
- Capable of Time Base Coordination with a minimum of 200 programmable steps.

All phases shall have the capability to be recalled to minimum green, maximum green, or pedestrian walk.

All timer units, where pedestrian timing is specified, shall rest in WALK display for Hebron Avenue unless otherwise specified.

Phase detection shall be capable of being declared as either locking or non-locking.

Software programming shall permit the controller unit to time concurrent phases, which shall have active detector calls.

The controller shall be programmable to start up in phases 2 and 6 amber and in phases 4 and 8 red intervals.

The controller unit shall have the capability of time based permissive force-offs. The controller unit shall support the ability to provide automatic calculations for computing the permissive period during coordination. This calculation shall not allow phase to be skipped during coordination. It shall not require the user to enter any data other than the split and cycle information. Calculations shall use the controller entries for phase timings to determine the permissive periods. The controller unit shall support the ability to open separate permissive periods for each phase. This shall support the ability to add unused non-coordinated phase time to the end of the coordinated phase.

The controller unit shall have the ability to store and to execute a minimum of:

- 24 timing plans;
- 16 splits;
- 16 phase omits; and
- 16 phase recalls.



The controller unit shall have the ability to create and store in memory:

- An event (including two levels of transit signal priority (TSP) requests (high and low)) and error log; and
- Log containing volume and occupancy values recorded by traffic detectors; it shall be possible to store data integrated over 5 minute periods (programmable) for at least 24 hours.

The controller unit's clock and memory shall be rechargeable and battery backed-up to retain time, date and signal timing data for a period of at least 30 days.

The communication protocol supplied with the controller shall allow the new TSCS to exchange data with the controller to provide the following functions:

- Status:
  - Current failures;
  - Vehicle and pedestrian display (red, amber, green) for all 16 phases;
  - State of actuating detectors;
  - State of pedestrian detectors;
  - Local pre-empts/priority including two levels of TSP (high and low); and
  - Progress of cycle time.
- Error and Event Log:
  - Upload and Clear.
- System Detector data:
  - Upload volume, occupancy and speed; and
  - Set integration period.
- Timing Plans:
  - Download and upload; and
  - Remote manual select.
- Time Base schedule:
  - Download and upload.
- Set date and time
  - Upload.

The controller unit shall have its own address for communication purposes. There shall be a minimum of 40 programmable addresses available.

The controller shall have input/output remapping features and/or logic programming. The controller unit shall have the ability to detect the occurrence of all-flash conditions and report through the controller timer to the Traffic Signal Control System using the communications protocol provided.

### ***Phasing***

The controller shall be capable of 16 phase operation with a minimum of four rings. Phases 1, 3, 5 and 7 shall be configurable as left turn arrows for 8 phase units and phases 1 and 3 must be configurable as either a left turn arrow and green ball or a flashing green aspect for 4 phase units. Phases 2, 4, 6 and 8 shall be solid displays with actuated parallel pedestrian indications.

For 16 phase units the vehicle phases will be assigned to phases 1 through 8 as described above, and the remaining phases will be used for transit (generally phases 10/12 and 14 and 16 in a dual ring configuration).

### ***Yellow Trap***

The controller shall be wired so that it cannot back up to service a left turn demand.

### ***Pedestrian Phases***

Pedestrian isolation circuits shall be provided for all pedestrian phases and shall be external logic units.

### ***Malfunction Management Unit***

The Malfunction Management Unit (MMU) shall meet all of the applicable portions of the NEMA TS2 2003 Section 4. The MMU shall detect and respond to improper and conflicting signals and improper operating voltages in a controller assembly. The MMU shall detect the presence of voltage on conflicting field connection terminals, the absence of proper voltages on all of the signal field connection terminals of a channel, and shall be capable of monitoring the presence of satisfactory operating voltages within the controller unit and MMU itself. The MMU, upon sensing any of these conditions, shall cause the transfer of the traffic signals to Flashing Operation, and the controller assembly shall be wired in such a manner as to provide Flash Transfer if the MMU is removed from service.

The MMU shall operate with the Type Select input at Logic Ground potential such that it is a Type 15 with sixteen channels. Each of the sixteen channels consists of three 120 volt AC inputs: Green/Walk, Amber, and Red/Don't Walk.

The Signal Monitor portion of the MMU shall be capable of monitoring for the presence of voltage on conflicting field connection terminals in the controller assembly. For the purpose of conflict determination, a signal on any of the Green, Amber, or Walk inputs associated with a channel shall be considered as that channel being active.

The Signal Monitor portion of the MMU shall also detect the absence of any required signal voltage on each channel at the field connection terminals in the controller assembly. For this purpose a signal on the Green/Walk, Amber, or Red/Don't Walk inputs associated with a channel shall be considered as that channel being active.

The Voltage Monitor portion of the MMU shall be capable of monitoring the Controller Unit Voltage Monitor output which indicates satisfactory operating voltage in the controller unit.

### ***Communication Protocol***

It is expected that signalized intersections to be initially connected to the selected TSCS are interconnected over a newly installed fiber communication network. Field communications processing shall be distributed between the central processors, and local field equipment.

The Contractor shall use open, industry standard protocols. At a minimum the TSCS shall have National Transportation Communication for ITS Protocol (NTCIP) 1202 Level 2 as defined by Section 3.3.6 of NEMA TS2-2003. NTCIP v02.06 capabilities shall include for all NTCIP mandatory and optional objects. The Proponent must demonstrate/document how they will guarantee compliance with NTCIP center-to-field communication protocol.

The Contractor shall support multiple traffic signal controller cabinet assemblies using this protocol. The Contractor shall describe what controllers they support in their proposal submission. The proposals will be evaluated as a total cost of ownership.

#### ***Communication Ports***

The controller unit shall be supplied with one port conforming to EIA-232 specification, and an Ethernet port. All ports and terminals shall be supplied with Keystone “Jack Screws” catalogue number 7230 or approved equal.

#### ***Detector Racks***

Each controller shall be equipped with specific racks fully wired for operation and complete with power supplies to accommodate detectors. For this application, the following shall be installed using a maximum of two racks:

- 8 position, 16 channel rack with US Traffic (UST) Model 222 rack mounted solid state detectors and RTC Model 380 Card Rack wired dual priority for fire pre-emption, but not including the card(s).

The detector rack(s) shall be compatible with TS2 Type 1 technology.

#### ***Bus Interface Unit NEMA TS2 Type 1***

The Bus Interface Unit (BIU) shall meet all of the applicable portions of the NEMA TS2-2003 Section 8 for Bus Interface Units for NEMA TS2 Type 1 controller cabinet assemblies. Bus Interface Units are required in the traffic signal controller cabinet assembly, TS2 Type 1, for connection between the controller and the terminal facilities and detector racks.

#### ***Cabinet Dimensions***

The outline dimensions of the cabinets shall be equivalent to a ConnDOT “D” cabinet, base mounted. The controller cabinet shall comply with NEMA standards and shall be made of aluminum, with a minimum thickness of the aluminum of 3.175 mm. All internal and external cut edges shall be ground smooth to prevent injury or damage. The cabinet shall be manufactured so as to prevent the accumulation of water on its top surface.

#### ***Door***

The cabinet shall have a hinged main door that permits access to all equipment within the cabinet and visual inspection of all indications and controls. The main door shall be not less than 1320

mm high by 845 mm wide. The size of the main door of the cabinet shall be substantially the full area of the front of the cabinet and shall include a 'door-in-door' for access to a police panel. The main door shall be provided with a door stop which holds the door open at a minimum of two positions (90 degree and 120 degree) open stop, which can be locked in place. The stop and catch mechanism shall be capable of holding the door open at 90 degrees with a load of 15 pounds per square foot applied uniformly over the face of the door. The doorstop shall be durable stainless steel, approximately 10 mm in diameter.

A three-point latch is required for the main door. The latching mechanism shall be constructed of heavy cadmium plated steel bar and nylon rollers on the locking bar, and a handle which will serve to secure the door.

The door handle shall be durable stainless steel, with a durable 12.7 mm shank, and shall be subject to approval by the Town. Provisions for padlocking shall be provided. The handle shall not impede the operation of the lock during opening. The controller cabinet shall come with a Pelco SM1026 door lock and key or approved equal.

#### ***Shelves***

The cabinet shall have provisions for positioning shelves to within 31 cm of the bottom of the cabinet and to within 20 cm of the top of the cabinet in increments of not more than 5 cm.

The cabinet will be supplied with 3 shelves, with the spacing to be determined by the Town. One of the three shelves shall have a sliding pullout shelf capable of safely supporting a laptop computer. The pullout shelf shall not interfere with the backboard or cabinet accessories and shall be a minimum of 40 cm x 26 cm (length times width).

#### ***Finish***

The cabinet shall be finished with gray polyester powder coat baked enamel.

#### ***Cabinet Ventilation***

The cabinet shall have a replaceable filter with the following dimensions: width 41 cm, height 31 cm, thickness 3 cm. The cabinet will have an air vent filter and removable aluminum cover.

#### ***Police Panel***

The police panel shall come complete with: signal switch, auto/flash switch, auto/manual switch, hand push button and retractable cord, Pelco SM1013 lock with key (or equivalent).

#### ***Thermostat***

The cabinet shall be equipped with an adjustable thermostatically controlled heater (bar type, minimum 250 W, CSA approved). The cabinet shall be equipped with an adjustable thermostatically controlled fan with manual control, which shall be vented to the outside. Thermostats shall be located so as to be easily accessible. Thermostat terminals shall be insulated to prevent accidental shock or shorting.

#### ***Cabinet Mounting***

The cabinet shall be base mounted. A Neoprene gasket shall be supplied for the base of the cabinet.

***Ancillary Requirements***

The cabinet shall come equipped with a clear plastic cover that covers the power supply.

The controller shall be equipped with back panel able to accommodate 12 three-phase output modules.

The controller shall be equipped with all load switches for the indicated 4, 8, or 16 phase operation, indicating lights for vehicles/pedestrian display shall be provided integral with the load switch.

The cabinet shall come equipped with two internal circuit breakers with labels, one for power feed and one for auxiliary equipment.

The cabinet shall come equipped with a radio interference filter.

The cabinet shall include lightning/high voltage surge protector, model HESCO HE1700RS, wired to provide “user defined input” capability.

The cabinet shall be equipped with two (2) - 110 V AC duplex power outlets (UL/CSA approved) equipped with a ground fault protection unit. One unit shall be located near bottom half of the cabinet and, the other located above the top shelf. The exact location is to be determined by the Town after the contract has been awarded and prior to installation.

The cabinet shall be equipped with 3-way switches inside the cabinet to simulate vehicle and pedestrian pulse and locking detector inputs directly to the controller. These switches shall, as a minimum, access the following features: stop timing, manual timing, manual interval advance and flash mode. These switches shall be designated such that up is on, down is momentary on and center is off. The switches shall be located so they cannot be activated by accident.

The cabinet shall be equipped with solid state flasher (minimum 15A, 2 poles).

The cabinet will include two Malfunction Management Unit (MMU) conflict sheets showing all conflicting displays with numbered circuits.

The cabinet shall be equipped with a lamp outlet complete with 60 W lamp and switch.

The cabinet will be supplied with two sets of equipment and electrical drawings, and one set of operations manuals.

The cabinet shall be supplied with a heavy duty Fellcoat Re-env EPPZ-C waterproof plastic pouch (44 cm x 35 cm) or approved equal capable of mounting to the cabinet door for the purposes of storing electrical and equipment drawings and manuals.

The Contractor shall provide a workable solution for all main panel wiring (wire size and colour coding).

The wiring within the controller cabinets shall be neatly arranged and laced, or enclosed in plastic tubing or raceway.

The controller and cabinet shall be configured to ensure that pre-emption related devices are powered from the rack and video processors are powered from the power supply through the provision of one (1) terminal for every two (2) video cameras used at an intersection.

The cabinet shall be set up to accommodate UPS, transfer switches and an external receptacle for portable generator power.

The Connecticut Department of Transportation Functional Specifications for Traffic Control Equipment, current edition governs the material for the Controller Assembly. The Functional Specifications are advertised biennial for vendors to provide equipment to the State on a low bid basis. All underlined text indicates an addition or revision to these specifications from the previous version. The Functional Specifications are available on the Departments website.

The following sections of the **Notice to Bidders**, pages 1 - 10, shall apply to contract supplied traffic controllers: 12, 15, 16, 17, 18, & 19.

Item 1108115A – FULL ACTUATED CONTROLLER 8 PHASE shall conform to the requirements of Section 1, pages 11 – 94. The Controller Unit (CU) shall conform to the requirements of Item 1D1, CONTROLLER (PRE-EMPTION TYPE), pages 29 – 31. All cabinets shall conform to the specifications of the “D” CABINET REQUIREMENTS, pages 78 – 84.

Controllers in a closed loop system shall conform to the requirements of Section 27, INTERNAL CLOSED LOOP SYSTEM FOR EXISTING NAZTEC SYSTEM, pages 160 – 183, in addition to the above requirements.

The solid state time switch shall conform to Section 13. FOUR CIRCUIT SOLID STATE TIME CLOCK WITH TIME BASE COORDINATION OPTION TC/TBC, pages 138 - 141.

Traffic signal equipment which has not been previously approved to meet the requirements of the Functional Specifications for the above items, will not be approved for use on this contract.

Several parts of Item 1 of the Functional Specifications do not apply to contract supplied and developer supplied traffic controllers. The specifications which are to be disregarded are listed below.

Item 1A-1 -Controller, Two Phase Microprocessor Keyboard Entry

- Type 6 Conflict Monitor  
Item 1A-2 - Two Phase Type "A" Cabinet

Supplemental specifications listed below, have been added for material and controller operations which the Department of Transportation does not include in the Functional Specifications for Traffic Control Equipment.

U.C.F. Time Switch Flash Command Procedure  
Time Clock/Time Base Installation Requirements

24 Volt Relay           Type A  
110 Volt Relay         Type F  
                              Type G

Time Delay Relay  
Non-Actuated Advance Green Phase  
Actuated Advance Green Phase  
Non-Actuated Clearance / Lag Green Phase  
Actuated Clearance / Lag Green Phase  
Flashing Stop Ahead Sign  
Max II Actuation By Pedestrian Call

**UNIFORM CODE FLASH COMMAND PROCEDURE**

1. Activate the **MINIMUM RECALL** input to the controller to ensure cycling prior to transferring to flashing operation.
2. Omit all non-actuated and actuated artery advance phases.
3. Omit phases 1 & 5 of all quad sequences.
4. Activate the **STOP TIME** input to the controller, upon entering flash, to prevent cycling.
5. Transfer to flash at the end of the last side street all red condition (at the point the artery **ON** output becomes active).
6. Special technical notes on the intersection plan supercede the above requirements.

**TC/TBC INSTALLATION REQUIREMENTS**

The following requirements are to be observed when engineering the installation of TC/TBC:

- 1 a. Circuit 1 shall be designated FLASH and be reserved for night flash command.  
b. Circuit 2 shall be designated MAX 2 and be reserved for Max 2 command.

- c. Circuit 3 shall be designated COORD and shall select coordinated operation of the intersection.
  - d. Circuit 4 shall be the yield, and force off command to the controller.
2. All clock outputs shall be active to select the function specified. For example; If the TC/TBC were removed for repair, no inputs would be applied to the controller. The intersection will then operate non-coordinated, in Max 1. Programming the TC/TBC without cycle and offset is not an acceptable method to create a non-coordinated operation. Refer to the typical hookup diagram.
  3. All TC/TBC clock installations shall be wired as detailed in figure 1. This method is used for both full and semi actuated operation.
  4. Midnight resync shall occur at 12:00 AM.
  5. A program card shall be completed indicating all input steps and settings. Four copies shall be provided. One copy left in the cabinet. Three delivered to the engineer along with the cabinet wiring diagrams.

TIME CLOCK / TIME BASE COORDINATION

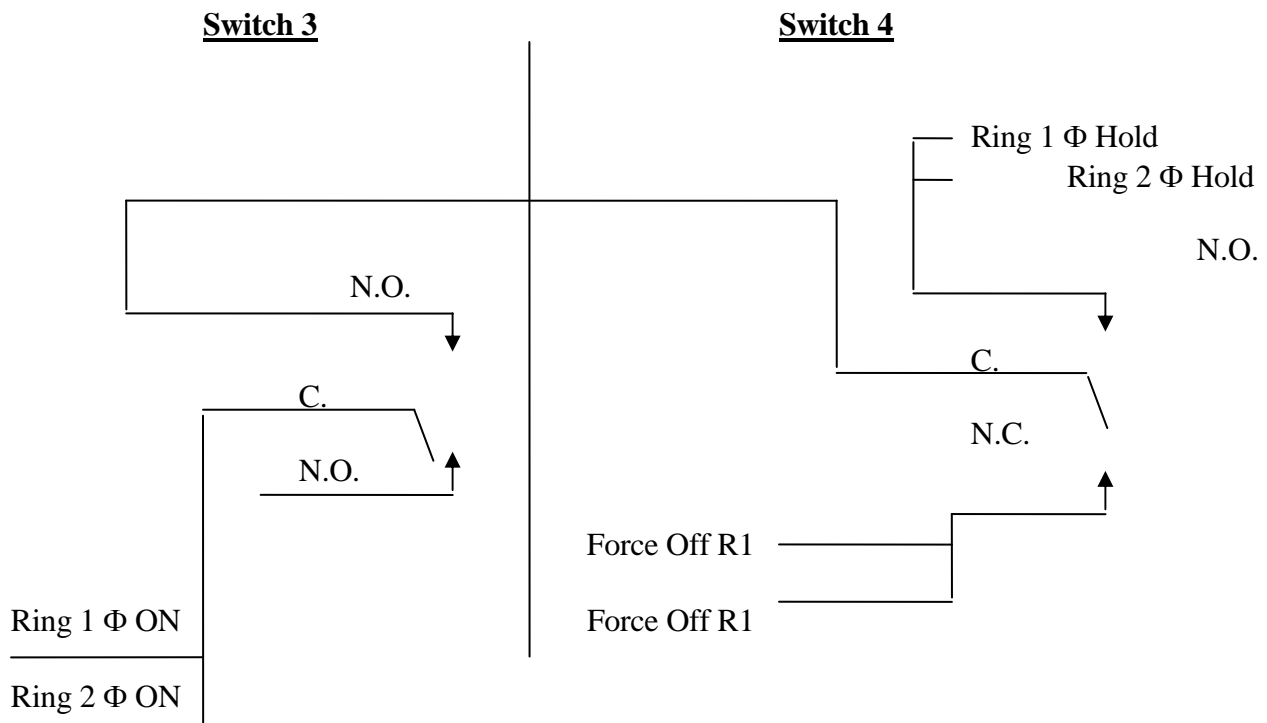

FIG. 1



## 24 VOLT RELAY

All 24 Volt relays shall meet the requirements of one of the following two types. Diodes shall be installed across the coils of all direct current relays to shunt the reverse voltage generated when the coil de-energizes. All diodes shall be general purpose ECG 125 1000prv @ 25A or equivalent, rated at least .5 amp forward biased. Diodes shall be external to the relay, not enclosed in the dust cover.

**TYPE A: Midland Ross, Midtex 155-92 or equivalent.**

### **DESCRIPTION:**

This relay shall be enclosed in a clear polycarbonate removable dust cover. It shall have a mechanical life of more than 100,000 operations at rated load.

### **CONTACTS:**

The contacts shall be 2 form C (D.P.D.T), U.L. rated at 5 amps 120 volts A.C. The contacts shall be pure fine silver (gold flash). There shall be no tungsten (lamp) load on the contacts of this relay.

**COIL:** The coil shall operate on 24 V.D.C. and have no less than 450 OHMS impedance.

**SIZE:** The relay shall be no larger than 65mm(2.5") H x 40mm(1.5") L x 40mm(1.5") W.

**BASE:** This relay shall have an eight pin octal plug-in base with the pin designation shown below:

1. Common (1)
2. Coil
3. Normally open (1)
4. Normally closed (1)
5. N.C. (2)
6. N.O. (2)
7. Coil (2)
8. Comm.

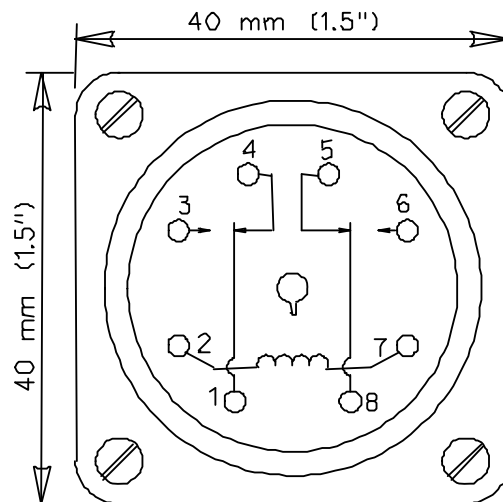

Bottom View And Wiring Diagram

**SOCKET:** The socket shall be a closed back, screw terminal type. The front mounted screws shall be 6-32 capable of accepting #14 AWG wire.

**110 VOLT RELAY**

All 110 volt relays shall meet the requirements of one of the following two types. Across the coil of each relay there shall be a molded suppressor rated at .1uf - 47 ohm @ 600V to suppress electrical noise created by the energization / de-energization of the relay.

**TYPE F:** Midland Ross, Midtex 136-62T3A1 or equivalent

**DESCRIPTION:**

Relays of this type shall function as flash transfer, power switching and signal drive. Other uses are acceptable, however, type G relays cannot be used for the above applications.

**CONTACTS:**

The contacts shall be in the D.P.D.T. form and consist of 10mm(3/8") diameter silver cadmium oxide, rated at 20 Amps @ 117 VAC resistive.

**COIL:**

The coil shall operate on 110 VAC. No semi-conductors will be allowed in the coil circuit of this relay.

**SIZE:**

The relay shall be enclosed in a clear plastic dust cover. The overall dimensions shall be no larger than 63mm(2 1/2") x 94mm(3 3/4") x 47mm(1 7/8") as illustrated below.

**BASE:**

This relay shall have an eight blade plug-in base, Ventron Beau Plug P-5408 or equivalent with the pin designations as shown below:

HEBRON AVENUE AND NEW LONDON TURNPIKE INTERSECTION  
SPECIAL PROVISIONS

BID #GL-2014-28

1. Coil
2. Coil
3. N.C. 1
4. N.C. 2
5. Comm. 1
6. Comm. 2
7. N.O. 1
8. N.O. 2

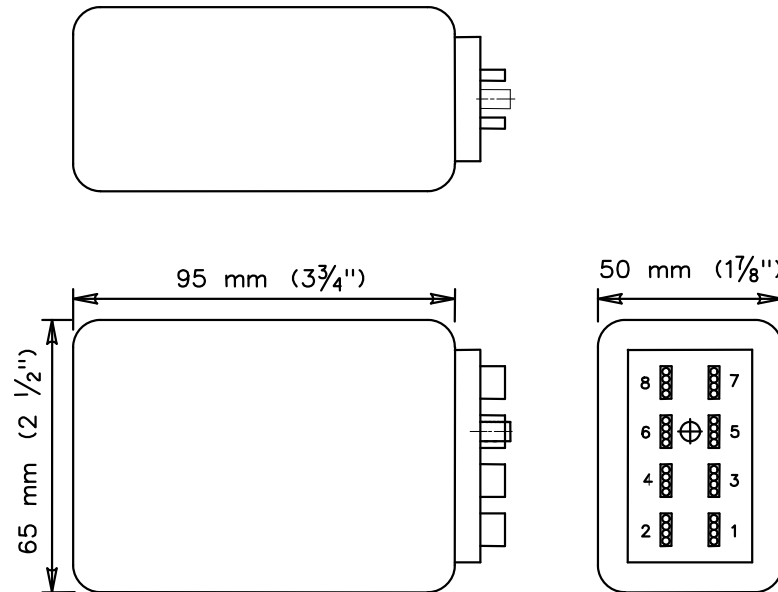

**SOCKET:**

The socket shall be Ventron Beau Plug S-5408 or equivalent, contacts rated at 15 Amps @ 1750 VRMS.

**TYPE G:** Magnecraft, W 88 ACXP-8 or equivalent

**DESCRIPTION:**

Relays of this type shall function in low current switching applications such as interconnect interface or pre-emption circuits. A clear polycarbonate plastic enclosure shall cover the relay mechanism.

**CONTACTS:**

The contacts shall be in the D.P.D.T. form and consist of 5mm (3/16") diameter gold flashed, silver alloy, rated at 10 Amps @ 120 VAC resistive.

**COIL:**

The coil shall operate on 120 Volts AC and require a nominal 3 VA.

**SIZE:**

Height, length and width dimensions shall be the same as the 24 volt relay Type A: 35mm(1 3/8") x 60mm(2 3/8") x 35mm(1 3/8").

**BASE:**

The base shall be an octal plug with the pin designations the same as the 24 volt relay Type A.

**SOCKET:**

The socket shall be the same as that for the 24 volt relay Type A.

**TIME DELAY RELAY**

120 VAC      SSAC TDM120A or equivalent  
24 VDC      SSAC TDM24DL or equivalent

**DESCRIPTION:**

The time delay relays shall be self enclosed, plug-in, delay on operate type. They shall be digitally timed and adjustable by the use of dip switches located on the top of the case. The timing range shall be 1 to 1023 seconds in 1 second intervals. The time delay relays shall have an internal double pole double throw relay with form "C" contacts rated at 10 amps 120 volts AC. They shall operate accurately in a temperature range of -20 to +65 degrees C. A 120 volt AC input shall initiate timing of the 120 VAC TDR and a 24 VDC input shall initiate timing of the 24 VDC TDR. Removal of the input voltage shall reset the timer. Maximum dimensions of the case shall be as shown below.

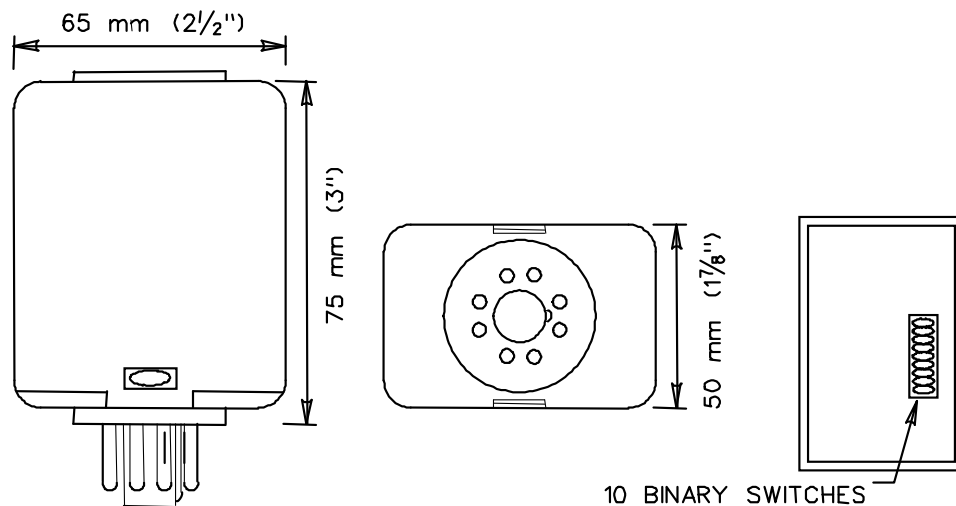

**SOCKET:**

The socket shall be a standard octal base (8 pin) with screw terminal connectors. The pin designation shall be as shown below.

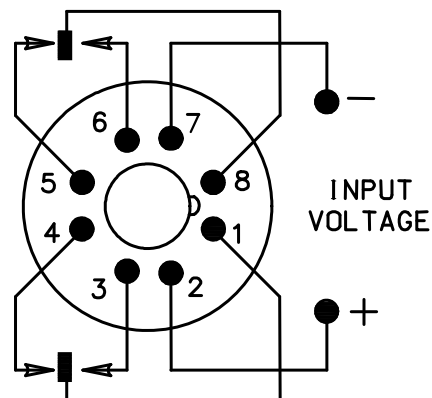

OCTAL (8 PIN) BASE

**NON-ACTUATED ADVANCE GREEN PHASE**

Where the timing and sequence indicates an advance green phase that always precedes the phase in recall (usually phase 2), and that either is fixed timed or is to be extended only, the following guidelines shall be in effect:

1. The parent phase ON output shall be diode connected to the advance phase OMIT input.
2. If the advance phase is to be extendable, it shall be in minimum recall. If the advance phase is fixed timed, it shall be in maximum recall. A different advance time may be selected by switching to maximum 2.

Example: Phase 1 is the advance phase (extendable), in minimum recall.  
Phase 2 is the artery, in recall.  
Phase 4 is the minor street, in non-lock.

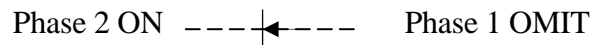

Where the timing and sequence indicates an advance phase that is fixed timed (not extendable), and that always precedes either a phase other than phase 2 or a phase not in recall, the following guidelines shall be in effect:

1. The recall phase (usually Phase 2) ON output shall be diode connected to the advance phase's, parent phase OMIT input.
2. The parent phase CHECK output shall be diode connected to the advance phase vehicle detector input.
3. The advance phase ON output shall be diode connected to the following parent phase vehicle detector input. This is to insure a green indication on the parent phase.
4. The advance phase shall be in the non-lock mode. The advance time shall be selected from the maximum interval.

Example: Phase 2 is the artery, in recall.  
Phase 3 is the advance for phase 4, in non-lock mode.  
Phase 4 (parent phase) is the minor street, in non-lock mode.

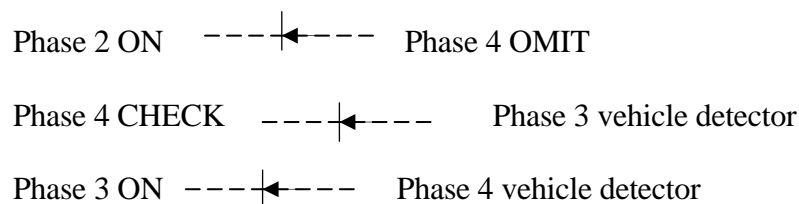

**ACTUATED ADVANCE GREEN**

Where the timing and sequence indicates an advance green phase that is to be extended only, and is to always precede either a phase other than phase 2 or a phase not in recall, the following guidelines shall be in effect:

1. The phase ON outputs of all phases that could precede the advance phase, shall be diode connected to the parent phase OMIT input.
2. The parent phase CHECK output shall be diode connected, through the normally closed contacts of a relay, to the advance phase vehicle detector input. The advance phase loop detector output shall be connected to the normally open contacts.
3. The relay coil shall be energized by the advance phase ON output, which in turn will switch the vehicle detector input from the parent phase CHECK circuit to the loop detector.
4. The advance phase ON output shall be diode connected to the following parent phase vehicle detector input. This is to insure a green indication from the parent phase.
5. The advance phase shall be in the non-lock mode.

Example: Phase 2 is the artery, in recall.  
Phase 3 is the pedestrian phase.  
Phase 4 is the advance for phase 5, in non-lock.  
Phase 5 (parent phase) is the minor street, in non-lock.

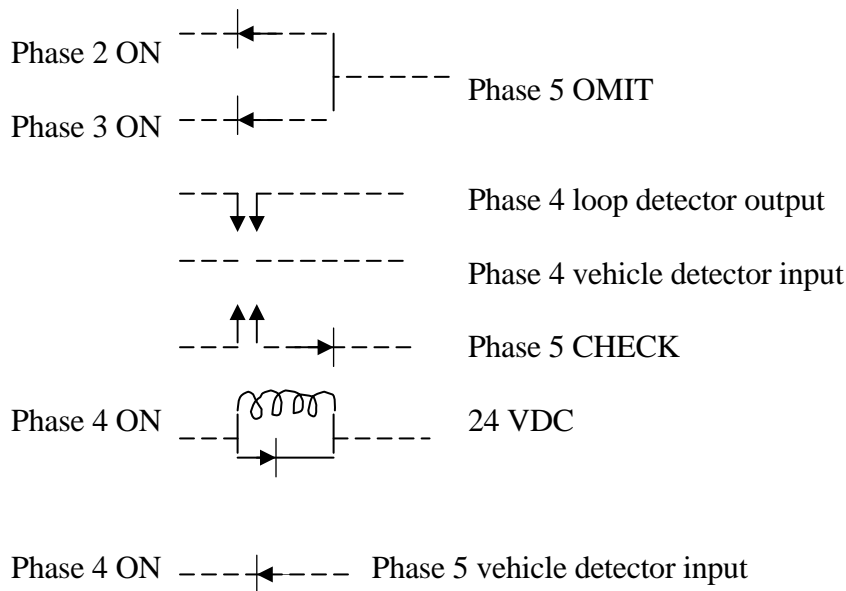

The 24 volt relay shall be Type C as previously described in these specifications.

**NON-ACTUATED CLEARANCE PHASE**

**NON-ACTUATED LAG GREEN PHASE**

Where the timing and sequence indicates a non-actuated clearance phase or a lagging green phase that always follows the phase in recall, the following guidelines shall be in effect:

1. The parent phase ON output shall be diode connected to all appropriate phase OMIT inputs except the clearance phase.
2. The remaining actuated phases shall have their CHECK outputs diode connected to the clearance phase vehicle detector input.
3. The clearance phase ON output shall be diode connected to the following phases vehicle detector input (if the phase is in non-lock mode). This will prevent the controller from returning to the parent phase from the clearance phase without servicing the minor street.
4. The clearance phase shall be in the non-lock mode.
5. The clearance, or lag green time shall be selected from the maximum interval.

Example: Phase 2 is the artery, in recall.  
Phase 3 is the clearance phase, in non-lock.  
Phase 4 is the pedestrian phase.  
Phase 5 is the minor street, in non-lock.

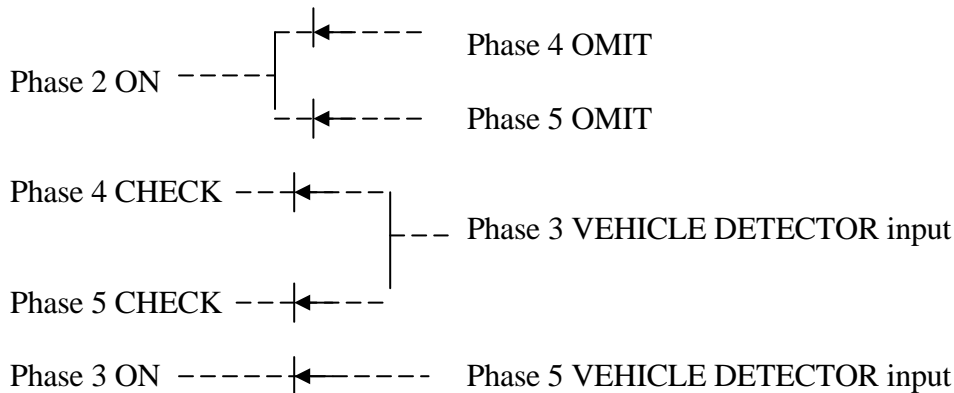

Where the timing and sequence shows a non-actuated clearance phase or lagging green phase following either a phase other than phase 2 or a phase not in recall, the following guidelines shall be in effect:

1. The parent phase ON output shall be diode connected to the following clearance phase vehicle detector input. This insures the clearance phase will always follow the parent phase.
2. The clearance phase shall be in the non-lock mode.

- The clearance, or lag green time shall be selected from the minimum green interval.



**ACTUATED CLEARANCE PHASE**

**ACTUATED LAG GREEN PHASE**

Where the timing and sequence indicates an actuated lagging green phase that is to be extended only, and always follows another phase, the following guidelines shall be in effect:

- The parent phase (usually phase 2) ON output shall be diode connected to the phase OMIT inputs of all phases that could follow the lag phase.
- The CHECK outputs of all phases that could follow the lag phase shall be diode connected, through the normally closed contacts of a relay, to the lag phase vehicle detector input. The lag phase loop detector output shall be connected to the normally open contacts.
- The relay coil shall be energized by the lag phase ON output which in turn will switch the phase detector input from the CHECK circuits to the loop detector.
- The lag phase shall be in the non-lock mode.

Example: Phase 2 (parent phase) is the artery, in recall.  
Phase 3 is the lag phase, in non-lock.  
Phase 4 is the pedestrian phase.  
Phase 5 is the minor street, in non-lock.

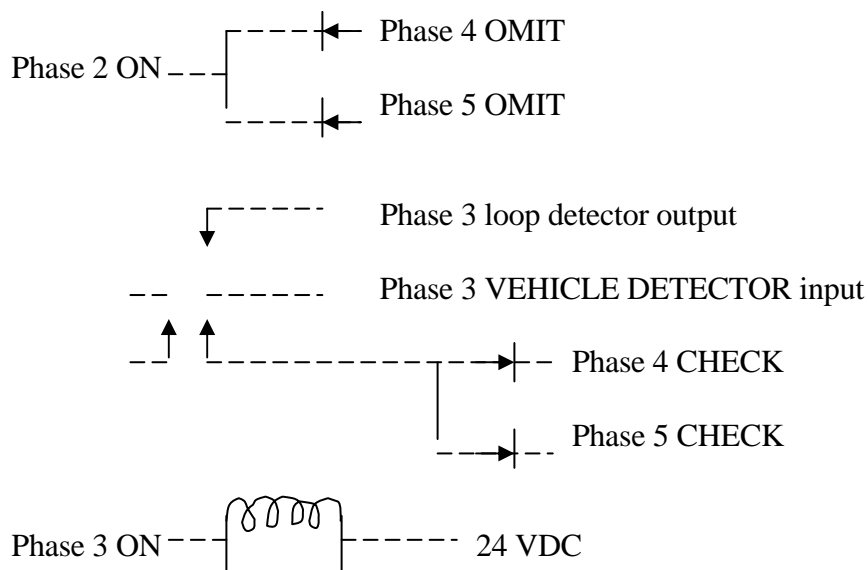



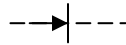

The 24 VDC relay shall be Type C as previously described in these specifications.

**FLASHING STOP AHEAD SIGN**

Where the timing and sequence indicates a flashing stop ahead sign, the clearance interval following the phase that the sign is off shall be timed by the following method.

The following phase shall be used for the clearance time. These phases shall be overlapped. The green indication will be maintained by the overlap feature and the following phase green time will be the stop ahead sign clearance.

The artery phase ON output shall be diode connected to all other phase OMIT inputs except the clearance phase and the artery phase. The CHECK outputs from the remaining phases (as needed) shall be diode connected to the sign clearance phase vehicle detector input. The clearance phase shall be in the non-lock mode.

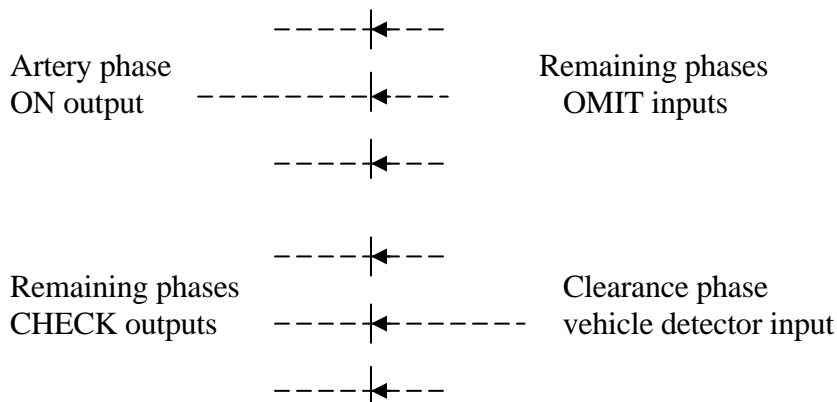

If the non-artery phases are in the non-lock mode, a call must be forced to the non-artery phase once the controller leaves the artery Hold interval (either artery walk or artery green). This prevents a false "Stop Ahead" indication if a vehicle turns right on red during the flashing sign clearance interval.

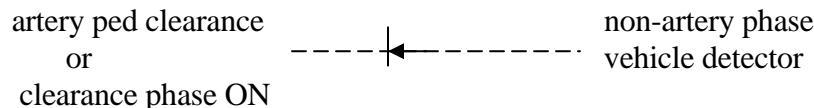

Unless otherwise shown on the plans, the 110 VAC flash power shall be from a spare load switch in the controller cabinet. The load switch input shall be driven with the flashing logic output from the controller. The flashing logic output shall be disconnected from the load switch during the intervals the sign is inactive.

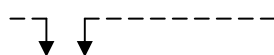

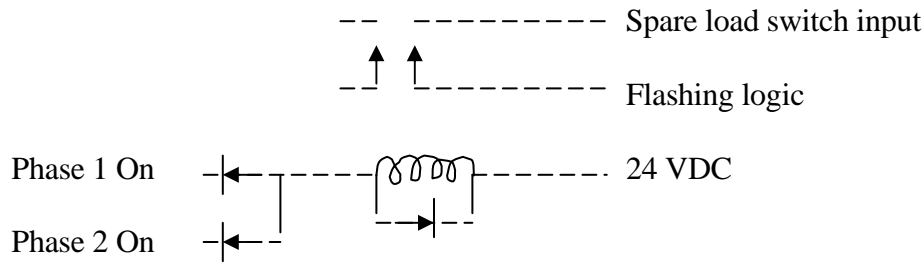

Typical drive circuit for “WHEN FLASHING STOP AHEAD” sign

**TIME BASE COORDINATION**  
**MAX II ACTUATION BY PEDESTRIAN CALL**

When the sum of the split times, including the walk and don't walk, exceed the background cycle length, the designer may choose to either allow a double cycle of the background timer or reduce the phase timings when the ped phase is called. Reduction of the phase timing by switching to MAX 2 avoids double cycling.

Where indicated on the plans the exclusive pedestrian phase will call MAX II. The minor movement max 2 times are set low so that the total phase times do not exceed the coordination cycle length.

Install a 24 volt relay connected to the inputs and outputs as shown on the following schematic.

Operation: When the controller advances to the exclusive pedestrian phase, the relay is actuated and latched. MAX II timing is selected for one complete cycle, until the relay is unlatched by the artery yellow (absence of red or green).

Example: Phase 2 is the artery. Phase 3 is the exclusive pedestrian phase.

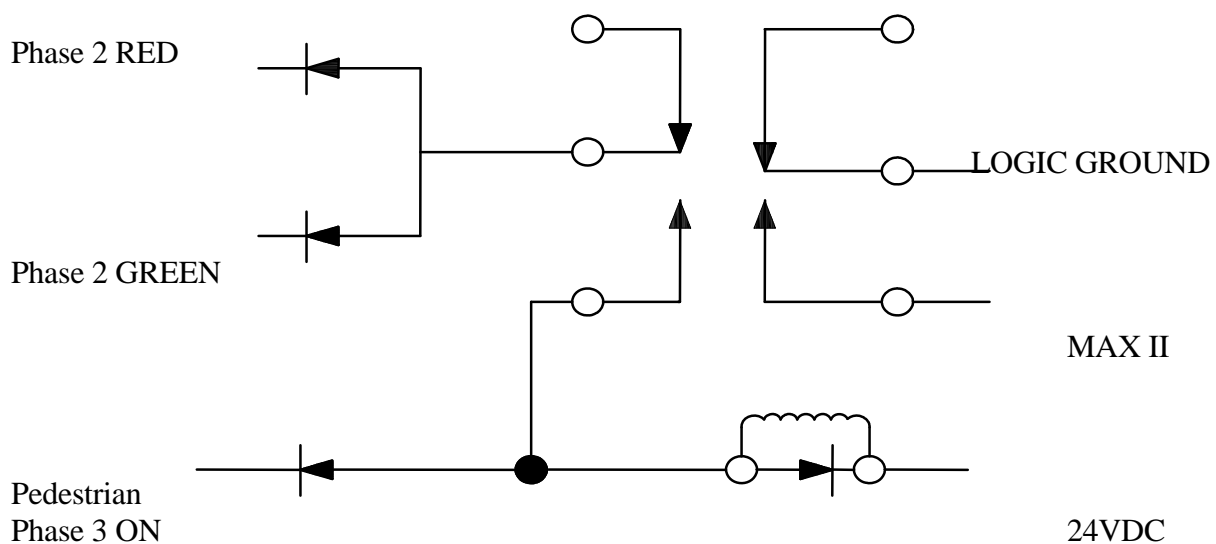

**ITEM # 1108722A**                      **VEHICLE EMITTER**

**ITEM # 1108724A**                      **PHASE SELECTOR**

**ITEM # 1112410A**                      **DETECTOR (TYPE A)**

**ITEM # 1112470A**                      **PRE-EMPTION SYSTEM CHASSIS**

**ITEM # 1113550A**                      **DETECTOR CABLE (OPTICAL)**

**SYSTEM DESCRIPTION:**

The emergency vehicle traffic signal priority control system shall enable designated vehicles to remotely cause the traffic signal controller to advance to and/or hold a desired traffic signal display by using existing controller functions. The control shall be activated at a minimum distance of 548.6M (1,800 feet) along an unobstructed "line of sight" path. The control shall not terminate until the vehicle is within 12.2M (40 feet) of the detector or at the intersection.

The system shall consist of the following components:

- A. Vehicle Emitter which shall be mounted on the emergency vehicle and shall transmit optical energy signals only in the forward direction. If the municipality presently uses optical pre-emption, the emitters shall be of the same manufacture currently used by the Town.
- B. Phase Selector (minimum 2 channel) which shall cause the signal controller to advance to and/or hold the desired traffic signal display for the emergency vehicle. A pre-emption system chassis shall house two phase selectors.
- C. Optical Detector which shall be mounted on or near a traffic signal and shall receive the optical energy signals generated by the Vehicle Emitter.
  - 1. Detector (Type A), 1 Direction, 1 Channel
- D. Detector Cable (Optical).

**System Operation:**

- A. The operating sequence shall be initiated when the optical detector receives the required optical energy signal from the Emitter.
- B. The phase selector shall cause the traffic signal controller to advance to and/or hold the desired traffic signal display for the emergency vehicle.
- C. The phase selector shall cause the controller to advance to and/or hold the desired traffic signal display even if the optical energy signals cease before the desired display is obtained.
- D. The phase selector shall allow the traffic signal controller to resume normal operation within ten seconds after optical energy signals cease if the optical energy signals cease after the desired traffic signal display is obtained.

- E. The phase selector shall not respond to optical energy signals from an emergency vehicle if it is already processing optical energy signals from another emergency vehicle.

**System Components:**

A. Vehicle Emitter:

The emitter assembly consists of an emitter and power supply and an emitter control switch assembly. The emitter assembly is mounted on a vehicle and produces a flashing optical signal when in operation.

1. Shall operate on ten to fifteen volts DC input voltage, but shall not be damaged by input voltage surges up to twenty-five volts DC.
2. Shall be controlled by a single on/off switch that requires no other adjustments by the operator. The on/off condition shall be indicated by a light located adjacent to the switch.
3. Shall be automatically disabled or de-activated by one or a combination of the following: seat switch, emergency brake switch, door switch, transmission safety switch.
4. Shall operate over an ambient temperature range of minus 34° C to plus 60° C. (minus 30° F. to plus 140° F.)
5. Shall operate in 0 to 95 % humidity.
6. Shall be a pulsed optical energy source with a controlled repetition rate.
7. Shall not generate voltage transients on the battery input line which exceed battery voltage by more than four volts.
8. Shall produce optical energy in a cone of not more than 90 degrees horizontal and not more than 30 degrees vertical. The detectors and/or phase selector shall not sense a pre-emption signal from an emitter outside this cone.

B. Optical Detector:

The optical detector receives the high intensity optical pulses produced by the emitter. These optical energy pulses are transformed by the detector into appropriate electrical signals which are transmitted to the phase selector. The optical detector is mounted at or near the intersection in a location which permits an unobstructed line of sight to vehicular approaches. The units may be mounted on signal span wires, mast arms or other appropriate structures.

1. Shall be of solid state construction.
2. Shall operate over an ambient temperature range of minus 34° C to plus 60° C. (minus 30° F. to plus 140° F.)
3. Shall have internal circuitry potted in a semi-flexible compound to ensure moisture resistance.
4. Shall operate in 0 to 95 % humidity.

5. Shall have a cone of detection of not more than 13 degrees. The detector and/or phase selector shall not sense a pre-emption signal from an emitter outside this cone.

C. Phase Selector:

The phase selector supplies power to and receives electrical signals from the optical detector. When detector signals are recognized as a valid call, the phase selector causes the signal controller to advance to and/or hold the desired traffic signal display. This is accomplished by activating the pre-empt input to the controller.

The phase selector is capable of assigning priority traffic movement to one of two channels on a first-come, first-serve basis. Each channel is connected to select a particular traffic movement from those normally available within the controller. Once a call is recognized, "commit to green" circuitry in the phase selector functions so that the desired green indication will be obtained even if optical communication is lost. After serving a priority traffic demand, the phase selector will release the controller to follow normal sequence operation.

1. Shall include an internal power supply to supply power to the optical detectors.
2. Shall have minimum two-channel operation with the capability of interfacing with an additional phase selector for expansion of channels of operation.
3. Shall have adjustable detector range controls for each channel of operation, from 12M (40 feet) to 548M (1800 feet).
4. Shall have solid state indicator lights for power on and channel called.
5. Shall operate over an ambient temperature range of minus 34° C to plus 60° C (minus 30° F. to plus 140° F.)
6. Shall operate in 0 to 95 % humidity.

D. Detector Cable (Optical):

1. 3-Conductor cable with shield and ground wire.
2. AWG #20 (7x28) stranded.
3. Individually tinned copper strands.
4. Conductor insulation: 600 volt , 75 deg. C (167° F.).
5. 1 Conductor-yellow; 1 Conductor-blue; 1 Conductor-orange.
6. Aluminized mylar shield tape or equivalent.
7. AWG #20 (7x28) stranded uninsulated drain wire
8. DC resistance not to exceed 11.0 ohms per 305M(1000 feet).
9. Capacitance from one conductor to other two conductors and shield not to exceed 157pf/M (48 pf./ft.).
10. Jacket: 600 volts, 80 deg. C (176° F.), minimum average wall thickness - 1.14mm (.045").
11. Finished O.D.: 7.62mm (0.3") max.

**System Interface:**

System shall be capable of operating in a computerized traffic management system when appropriate interfacing is provided by the computer supplier.

**General:**

The Contractor shall furnish the manufacturer the phasing diagrams indicating controller sequence and timing.

The Contractor shall secure from the manufacturer a guarantee for the equipment for a period of sixty (60) months, which time shall commence from the date of delivery. Manufacturer shall certify upon request that all materials furnished will conform to this specification. The manufacturer or his designated representative shall be responsible for determining and setting all required range and emitter intensity for the emergency vehicle operation.

**Construction Methods:**

All equipment except the vehicle emitter assembly shall be installed and wired in a neat and orderly manner in conformance with the manufacturers' instructions. The vehicle emitter assembly shall be delivered to a designated town representative. Installation of the vehicle emitter assembly shall be the responsibility of the town.

Traffic signals owned and maintained by the State that have optical pre-emption equipment owned and maintained by the town shall have an Auxiliary Equipment Cabinet (AEC) attached to the controller cabinet. The optical pre-emption equipment shall be housed in the AEC. Traffic signals owned and maintained by the town do not require an AEC to house the pre-emption equipment.

Detector cables shall be continuous with no splices between the optical detector and the AEC.

Detector locations shown on the plan are for illustration purposes only. Exact location shall be determined by the contractor or the designated representative for the best possible line of sight.

If not present in an existing traffic controller cabinet, the following items shall be installed and connected, in conformance with the current Functional Specifications for Traffic Control Equipment, "D" Cabinet Requirements (Pre-emption Type):

- Controller "D" harness and adapter.
- Pre-emption termination panel with terminal block and relay bases.
- Pre-emption disconnect switch, mounted on the emergency switch panel (on inside of cabinet door).
- Pre-emption test buttons, mounted on the pre-emption termination panel.

All connections from the phase selector to the "D" harness and to the cabinet wiring shall be made at the termination panel. The termination panel shall have AC+ Lights, AC-, and a switched logic ground. The switched logic ground feeds all the pre-empt inputs to the phase selector. When switched off by the pre-emption disconnect switch, the traffic controller shall not be affected by pre-empt calls from the optical pre-emption system. A minimum of two test buttons shall be provided. If there are more than two pre-empt runs, a button for each shall be installed. A chart or print out indicating the program steps and settings shall be provided along with the revised cabinet wiring diagrams.

**Test the Pre-emption System According to the following Guidelines:**

1. Notify the system owner/user, such as the municipal fire chief or public works director, of the scheduled inspection
2. Request a fire department representative and an emergency vehicle, which has an emitter to conduct the test. If not available, the contractor shall provide an emitter.
3. In the presence of the Engineer and the municipal representative, test each pre-empted approach with the emergency vehicle. Test the following items of the system:
  - \*Confirm that the emitter activates the phase selector and the phase selector activates the correct pre-emption input to the controller.
  - \*Confirm adequate range. The traffic signal must be pre-empted to green sufficiently in advance of the emergency vehicle arrival. The vehicle emitter shall initiate pre-emption at a minimum distance of 548.6M (1800 feet).
  - \*Confirm there are no false calls. Keep the emitter active as the emergency vehicle passes through the intersection. No other optical detectors shall sense the strobe.
4. Document the test. Provide the Engineer and, upon request, the municipality copies of the test results.

If a malfunction is found or the system needs adjustment (such as range, emitter intensity, or detector location), schedule a follow-up test. Repeat the above steps for all approaches that did not pass.

All adjustments such as emitter intensity, phase selector range, sensitivity, detector placement, shall be made at the intersection by the contractor so that the optical pre-emption operates correctly with other major manufacturers' equipment currently owned by the town.

**Method of Measurement:**

Optical Detectors, Phase Selectors, System Chassis will be measured for payment by the number of each supplied, installed and accepted. Detector Cable (Optical) will be measured by the number of meters (linear feet) supplied, installed and accepted. Vehicle Emitters will be measured by the number of each supplied to the Town and accepted.

**Basis of Payment:**

Payment for Optical Detectors, Phase Selector, System Chassis and Detector Cable (Optical) will include the item unit cost, including all manufacturer's required mounting hardware and the cost of installation and supervision by the manufacturer or his designated representative, including travel and subsistence, and all materials, equipment and labor incidental thereto. Payment for termination panel, "D" harness, test buttons, program chart (or print out) and revised cabinet wiring diagrams shall be included in the item PRE-EMPTION SYSTEM CHASSIS. Payment for Vehicle Emitters will include the item unit cost only.

**ITEM # 1111407A                      CAMERA VIDEO DETECTION SYSTEM**

**Description:**

These items shall consist of furnishing and installing vehicle Video Detection System equipment at each of the project intersections as called for on the plans. This item shall also consist of furnishing and installing all vehicle video detection equipment to support the Town of Glastonbury signal system data collection management software or approved equal. This specification sets the minimum requirements for a wide-area vehicle detection system that processes video images for vehicle presence, count, speed, and other typical traffic parameters. The detection of vehicles passing through the field of view of an image sensor shall be available to a large variety of end user applications as simple contact closure outputs, data for a traffic controller, and other traffic data. This reflects the current real time detector or alarm states (on/off) or as summary traffic statistics that are reported locally or remotely. The contact closure outputs shall be provided to a traffic signal controller and comply to the NEMA

(National Electrical Manufacturers Association) TS2 input file rack standards. The system architecture shall fully support networking of system components through a variety of industry standard and commercially available infrastructure that are used in the traffic industry. The serial data communications shall support direct connect, modem, and multi-drop interconnects.

The system shall be integrated through a client-server relationship. A communications server application shall provide the data communications interface between as few as one to as many as hundreds of machine vision processor (MVP) sensors using the industry standard TCP/IP network protocol. Communications protocol for the proposed machine vision system must be compatible with the existing machine vision system infrastructure to support current data collection processes.

**Materials:**

All materials furnished, assembled, fabricated, or installed shall be new, corrosion resistant, and in strict accordance with the details shown in the plans and in the Special Provisions. All equipment furnished under this item shall be current production equipment, identical models of which are field operational.

- The video detection system shall consist of the following components:
- Camera Risers, installation and removal tools
- Machine Vision Processor (MVP) including camera and enclosure
- Communication Interface Panel (CIP)
- Cabinet Interface Module
- Video Detection System Software
- Traffic Data Collection
- Camera Cable

All MVP Processors and components shall be of the same type and from the same manufacturer.

The MVP image sensor shall communicate with the cabinet interface module via the communications interface panel. The MVP shall be connected from the field to the communications interface panel using the twisted pair camera cable as specified herein. The MVP image sensor shall communicate to the communications interface panel, cabinet interface module and various PC applications using the industry-standard TCP/IP network protocol. Additionally, one or more PCs shall be capable of communicating directly or remotely to a MVP sensor network where each MVP sensor has a unique Internet Protocol (IP) address. The MVP sensor network shall support communications over a mix of media, including PSTN, CDPD, CDMA, dedicated twisted-pair, fiber, and wireless.



The communications interface panel shall support one to eight MVPs. The communication interface panel in the cabinet shall provide electrical termination for the MVP sensor. The communication interface panel shall provide transient protection to electrically protect equipment in the cabinet. The communications interface panel will provide for supervisory connectivity via a RJ-45 Ethernet Port. The use of Serial to Ethernet converters will not be acceptable. The communications interface panel consists of a predefined wire termination blocks for MVP Broadband Over Power (BOP) communications, electrical surge protectors to isolate the modular cabinet interface unit and MVP, and an interface connector to cable directly to the modular cabinet interface unit. The connection from the MVP(s) to the communications interface panel shall be via the manufacturers supplied three wire cable with Easy-Lock connector to sensor. Splices between the MVP and the communications interface panel shall not be allowed. The interface panel shall provide power for one to eight MVP(s), taking local line voltage and coupling it with Ethernet protocol communications for the Broadband Over Power termination at about 15 watts.

The cabinet interface module shall communicate directly with up to eight (8) MVP sensors and shall comply with the form factor and electrical characteristics of a NEMA TS2 detector rack. For a contact closure interface to a traffic controller or other device, this interface shall accept sixteen (16) contact closure inputs (usually red and green control signals), and provide twentyfour (24) contact closure outputs to a traffic signal controller. For a SDLC interface to a NEMA TS2 traffic controller, this interface shall provide thirty-two (32) TS2 inputs for phase/load switch status, sixty-four (64) TS2 detector outputs and emulate up to four (4) bus interface units (BIU).

**Camera Riser:**

As called for on the plans, these camera risers to be mounted behind signal heads as shown on the plans and illustrated in the figure attached after this section. These camera risers shall be paid each under this Item # 1111407. The camera riser shall match the external finish of the traffic signal pole.

**Machine Vision Processor including camera and enclosure:**

The MVP image sensor shall be an integrated imaging color CCD array with optics, high-speed, image processing hardware and a general purpose dual-core CPU bundled into a sealed enclosure. The CCD array shall be directly controlled by the CPU, thus providing high video quality for detection that has virtually no noise to degrade detection performance. It shall be possible for the user to zoom the lens, as required for operation. The MVP shall be able to transmit MPEG-4 video streams to remote locations. This requirement is described further in the video outputs section. It shall provide a video compression co-processor so as not to interfere with detection performance while streaming video. The MVP shall provide direct real-time iris and shutter speed control. The MVP image sensor shall be equipped with an integrated auto zoom/auto focus lens that can be changed using computer software.

The MVP sensor shall output MPEG-4 streaming video utilizing Broadband Over Power via a single RJ-45 Ethernet Port on the communications interface panel.

Real-time detector performance shall be observed by viewing the video output from the sensor with overlaid flashing detectors to indicate the current detection state (on/off). Real-time speeds and classifications shall also be visible through streaming video via the video player.

**Video Outputs:**

The MVP shall provide MPEG-4 color video output from the interface panel for real-time display on a PC using an Ethernet cable from the communications interface panel or to a monitor over standard coax cable from the cabinet interface module. The software shall also display streaming video as part of the user software based on MPEG 4 video compression. The MPEG-4 video compression shall be accomplished internally through software. No external video encoders are required. The MPEG 4 video compression shall be able to be viewed for individual cameras simultaneously on a PC. The streaming video shall be

recordable as a data file on the PC for later playback and editing. The Machine Vision Processor (MVP) including camera and enclosure shall meet the following requirements:

Lens

- 22X continuous-focus zoom
- Horizontal: 5 to 74 degrees
- Vertical: 4 to 59 degrees

Imaging Device

- 1/4" color CCD

Video Formats Supported

- RS170, NTSC, CCIR and PAL

Video Compression

- MPEG-4 color video compression (software)

Resolution

- 470 TVL Horizontal

Effective Pixels

- NTSC :768(H) x 494(V) [380k]
- PAL: 752(H) x 582(V) [440k]

Synchronization

- Crystal lock

Sensitivity—at Lens

- Full video, AGC off, 2 lux
- Signal to Noise Ratio 50 dB

Communications

- Connector: EasyLock (IDC rapid termination industrial connector)
- Internet Protocol (IP) address
- RJ-45 Ethernet communications

Housing & Sunshield

Image sensor and MVP shall be sealed in a waterproof and dust-tight NEMA4 (IP66) enclosure. The housing shall include a thermostatically controlled ITO faceplate heater, Hydrophilic faceplate coating, weather proof connector and an adjustable weather and sun-shield with drip guard.

Power

- 110/220 VAC 50/60Hz
- 15 watts with heater on

Dimensions

- Mounting: Standard camera bracket tilt top
- Housing Enclosure: 3.5" diameter, 15.5" long
- Weather sunshield: 21.3" long

Weight

- 6.6 lbs.

Ambient Temperature Limits

- -34°C to +60°C / -29°F to +140°F

Humidity Limits

- Up to 100% relative humidity per MIL-E-5400T Paragraph 4.3.24.4

**Camera Cable:**

The Color Camera / Integrated Machine Vision Processor cable shall use 3-Conductor, 18AWG Polyethelene Jacketed conduit rated power cable. The cable shall supply 110VAC power to the camera and bi-directional data communications and video between the MVP and CIP. Coaxial cable will not be allowed from MVP to traffic control cabinet. This camera cable shall be installed from the video detection camera/integrated Machine Vision Processor back to the communications interface panel

The cable outside jacket material shall be black UV resistant Santoprene 121-87, with a nominal wall thickness of 0.05" and a 600v (RMS) rating. The cable identification shall be marked with the manufacturer's part number at regular intervals along the cable.

**Communications Interface Panel (CIP):**

The communications interface panel shall provide power, high-voltage transient protection, mechanical strain relief and electrical connections to the Color Camera / Integrated Machine Vision Processor for communications and video. The communications interface panel shall also act as a terminal for Ethernet network communications. The communications interface panel shall contain an industry standard RJ-45 type connector for CAT-6 cable interface. A single communications interface panel shall provide for a termination of one to eight MVPs and a single 10/100 Base-T Ethernet network cable. The communications panel shall pass the detection information to the cabinet interface module. The communications interface panel consists of a predefined wire termination block for MVP power, data and video connections, electrical surge protectors to isolate the modular cabinet interface unit and MVP, and an interface connector to cable directly to the modular cabinet interface unit. In addition to the RJ-45 Ethernet port, the communications interface panel shall have at a minimum, a detector communications port, four sets of 3 compression terminals to support up to eight MVPs, and a compression block for power connection.

The Communications Interface Panel (CIP) shall meet the following requirements:

General

- Auto-Sensing 10/100Base-T network interface with on-board RJ-45 connector
- Robust on-board IP Stack: TCP, UDP, DHCP, SNMP, SSL/TLS, HTTP,
- SMTP, ICMP, IGMP and ARP
- Secure web-based configuration (HTTP/HTTPS)
- Universal IP address assignment
- Configuration and management through SNMP (read/write)

Connectors

- Ethernet Connectivity Upstream:
  - RJ-45 Connector
- Local and Remote Supervisor Capability
  - Network Browser via Ethernet RJ-45
- Detector Communications Port
  - Single FireWire Female Connector
- MVP Terminations
  - Four sets of 3 compression terminals
- Line Power
  - 3 Position Compression Block

Environmental

- -34°C to +74°C / -29°F to +165°F
- Up to 100% relative humidity per MIL-E-5400T per Paragraph 4.3.24.4

**Cabinet Interface Module**

The cabinet interface module shall provide the interface between the MVPs and the traffic signal controller. The cabinet interface module shall also be referred to as the "Access Point" or the detector port master. The cabinet interface module shall be capable of supporting up to eight MVPs in a single cabinet. The cabinet interface module shall be a single card rack device that can slide easily into a detector rack or be connected as a stand-alone device using a housing with power connector. The cabinet interface module shall provide real-time detection information from the MVP to the traffic signal controller.

The cabinet interface module shall communicate directly with up to eight (8) MVP sensors and shall comply with the form factor and electrical characteristics of a NEMA type C or D detector rack. The cabinet interface module shall be capable of emulating the functions of up to four Bus Interface Units (BIUs).

The cabinet interface module shall be capable of simultaneously providing NEMA TS 1 / 170/2070, and NEMA TS2 outputs to the traffic control cabinet.

The cabinet interface module shall meet the following requirements:

Environmental

- -34°C to +74°C / -29°F to +165°F
- 0 to 95% relative humidity

Outputs

- 24 optically-isolated NEMA TS1/TS2 outputs

Inputs

- 16 optically-isolated inputs to monitor signal controller phases or other conditions

Connectors

- Female I/O connector 44-socket metal shell D subminiature connector
- Female 15-pin metal shell D subminiature connector
- Cinch Jones 50-44A-30M edge connector
- BNC
- Two (2) USB for USB Mouse

Power

- 20 to 28 VDC, 100 milliamps, not exceeding 5 watts (Operates at 24 VDC as allowed in section 5.3.4.5 of the TS2 standard)

TS2 Capability

- Fully comply with NEMA Publication Standard TS2-1998

Power

- 12 to 24 VDC, 100 not exceeding 11 watts .(Operates at 24VDC or at 12VDC as in section 5.3.4.5 of the TS2 standard)

**Video Detection System Software**

The MVP sensor's embedded firmware shall automatically perform a variety of diagnostic, installation, fault tolerant, and vehicle detection operations. Vehicle detection shall be reliable, consistent, and perform under all weather, lighting and traffic congestion conditions.

A software suite of client applications shall reside on the host client / server PC. The software suite shall support Microsoft Windows XP, NT, 2000 and later operating systems. Client applications shall include:

**Network Browser:**

Learn a network of connected modular cabinet interface units and MVPs then show the topology in a logical hierarchical relationship.

**Detector Editor:**

Create and modify detector configurations to be executed on the MVP sensor.

**Operation Log:**

Extract the MVP run-time operation log of special events that have occurred.

**Software Installer:**

Reconfigure one or more MVP sensors with a newer release of embedded system software.

**Video Player:**

Play streaming color video from any or all sensors connected to network. Video player shall also have the ability to go in to a video wall option which will divide the PC screen in as many sensors

that are opened giving the user optimal viewing. The video player shall also be able to record and play back any or all sensors being viewed.

**Video Controller:**

Control the zoom, pan & tilt (optional) of the sensor it is controlling. Multiple sensors shall be able to be viewed or controlled at the same time. If multiple sensors are being viewed simultaneously, the video controller application shall allow the user to enlarge the screen in to a video wall option, which will split up the whole screen with the number of sensors being viewed.

**Detection Types:**

The MVP shall be able to be programmed with a variety of detector types that perform specific functions. The general functions performed by the detectors shall:

- Include presence/passage detection of moving and stopped vehicles.
- Enable detection based on the direction of travel or based on when a moving vehicle stops.
- Measuring vehicle speed and length and provide five (5) classes of vehicles based on length.
- Determine counts, either lane-by-lane or cumulative.
- Speed alarm detectors:
  - Output alarm on each fast vehicle, ignoring vehicles of length of less than the user defines.
  - Output alarm based on the average number of vehicles the user enters and the upper and lower speed thresholds that the user defines.
  - Output alarm based on the average speed over a user defined time frame.
  - Output alarm based on user-defined percent increase or decrease over a speed limit.

**Detection Zone Programming**

Placement of detection zones shall be by means of a supervisor computer (PC) operating in the Windows 2000 or Windows NT graphical environments, a keyboard, and a mouse. The VGA monitor shall be able to show the detection zones superimposed on images of traffic scenes.

The detection zones shall be created and/or edited by using a mouse to draw detection zones on the supervisor computer's VGA monitor. Using a mouse and the keyboard it shall be possible to place, size, and orient detection zones to provide optimal road coverage for vehicle detection. It shall be possible to download detector configurations from the supervisor computer to the MVP, to retrieve the detector configuration that is currently running in the MVP, and to back up detector configurations by saving them to the supervisor computer's removable or fixed disks.

**Traffic Data Collection**

The MVP sensor shall optionally store cumulative traffic statistics, internally in non-volatile memory, for later retrieval and analysis. MVP sensor shall have at least 5 megabytes of memory for data storage. The following data types are available to be stored in time increments from a cycle to one-hour increments:

- Average Flow Rate
- Total Volume Count
- Arithmetic Mean Speed
- Vehicle Class Count
- Average Time Headway
- Average Time Occupancy
- Level of Service
- Space Mean Speed
- Space Density
- Density

The above data types shall also be available to be viewed real-time through a standard web browser compatible with the existing Town of Glastonbury data collection and management service (DCMS.) The

manufacturer shall modify the existing Town of Glastobury web page interface/GIS map to include all video detection sensors as part of this project.

This DCMS shall have the capability of polling an unlimited number of video detector sensors via the fiber optic Ethernet based communication interface. The DCMS shall then display the data real-time on the Town of Glastonbury custom website. It shall be the responsibility of the manufacturer to make all necessary modifications to this website. The manufacturer shall also supply all necessary cables and hardware at the Town of Glastonbury Traffic Operations Center to provide for a fully operational website displaying real-time data. In addition to displaying realtime data and color snapshots of the image sensor, the manufacturer shall archive all data for the agency to create custom data reports in Excel or HTML by simply accessing the website and filtering the dates and reporting parameters.

**System Installation**

The supplier of the video detection system shall supervise the installation and testing of the video detection system and computer equipment. A factory certified representative from the supplier shall be on-site during installation.

**Warranty, Service and Support**

The Video Detection manufacturer shall, for a minimum of five (5) years, warrant the video detection system including all software upgrades free of charge for duration of warranty period.

**Method of Measurement:**

The MVP Color Camera / Integrated Machine Vision processor system or approved equal will be measured for payment as the number units furnished, installed, made fully operational and tested. MVP Color Camera / Integrated Machine Vision processor Cable will not be measured for payment but included in the cost as furnished, installed made fully operational and tested.

**Basis of Payment:**

The unit price bid for each MVP Color Camera / Integrated Machine Vision processor or approved equal System item shall include the cost of furnishing four (4) MVP Unit(s), one (1) CIP-8 (per 8 MVP Units), camera cable and one (1) cabinet interface module (detector port master) and all associated enclosures and equipment and all labor, training, materials, cables, tools and equipment necessary to complete the work. Payment for the MVP Comm. Server configuration software, all miscellaneous hardware, cabling, connectors, documentation, test equipment, and testing shall be included under these items. The unit price bid shall also include the cost of furnishing all labor, materials and tools and equipment necessary to complete the work and to make the system fully operational.

**ITEM # 1113812A UNINTERRUPTIBLE POWER SUPPLY (UPS)**

**DEFINITIONS**

**UPS:** means Uninterruptible Power Supply.

**AGM VRLA Battery:** means sealed battery using Absorbed Glass Mat & Valve Regulated Lead Acid technology

**Gel Cell Battery:** means sealed battery contains acid in a gel form so it does not leak.

**MATERIALS**

**1.1 General**

The UPS system shall provide uninterruptible power and conditioning of the utility power required for the operation of all electronic equipment used to operate the traffic control signals in the event of main utility power supply failure or voltage or frequency fluctuations.

The UPS system shall be supplied complete with UPS automatic switch.

The UPS control unit shall be a line interactive or double conversion type with automatic voltage regulation for 120V, 60Hz, single phase.

The UPS system shall include all wiring necessary to interconnect the UPS control unit to the power source and to the traffic signal control components.

The UPS control unit must latch from line to battery and from battery to line (transfer time) in less than 60 milliseconds.

When installed at a traffic signal using LED signal lamps, the UPS system shall be capable of maintaining full signal display operation for a minimum of 4 hours after which it shall be capable of maintaining a flashing signal display for a further 6 hours minimum.

Switching from full operation to a flashing operation may be determined by a timer circuit or based on battery capacity.

If the UPS control unit or the batteries fail, the system shall automatically switch back to utility line power.

The UPS cabinet shall be supplied complete within the traffic signal controller based mounted cabinet as indicated in the Contract Documents.

The battery installation and wiring to the batteries shall be according to National Electric Code requirements as applicable.

The UPS system components shall operate properly for the time periods specified above under the following conditions:

- Ambient temperature -37 o C to +74 o C
- Humidity: 5 percent to 95 percent
- The UPS system components shall withstand shock and vibration according to NEMA TS 2-2003

### **5.3 Batteries:**

Batteries shall be AGM VRLA or Gel Cell technology.

Battery leads to UPS control unit shall be of suitable length and not less than 2.5 metres.

Each battery shall be placed on its own heater mat with all heater mats being supplied with AC power by the UPS control unit.

Battery mats shall become inoperable with loss of line voltage.

The batteries shall be protected by a circuit breaker or a fuse.

Each battery shall be labelled with the date of manufacture. The label shall be at a visible location on the top of the battery.

In addition to any other warranty, the Contractor shall provide a 3 year warranty on the batteries. The warranty period for each battery shall be 3 years, commencing from the date of "switch on" for operation of the UPS system in which the batteries are used. Any defective battery shall be replaced within 30 days. The warranty shall include all labor, equipment, and materials required to replace the batteries, including traffic control and all removal and disposal work. The Contractor shall be responsible for the removal and disposal of any defective batteries replaced under warranty. The Owner shall be the sole judge in determining if a battery is defective.

### **1.4 UPS Control Unit**

The UPS control unit shall be rack mountable with the following maximum dimensions: Width of 483 mm (19-inch), depth of 254 mm (10 inches), and height of 153 mm (6 inches).

The front face of the control unit shall have indicators capable of displaying the following:

- Number of times the system was on battery supply
- Total time on battery supply
- Battery charge status to indicate the battery capacity

Each of the battery supply indicators listed above shall have a manual reset switch.

The UPS control unit shall have a minimum of one standard 120V grounded socket located on either the back or the front panel.

The UPS control unit shall contain over-current protection located on the front panel to switch power On/Off from the batteries and to switch AC input and output power On/Off.

The UPS control unit shall have a self-test feature to test the UPS Automatic Switch and the control circuitry.

The UPS control unit shall have an open collector output or an AC or DC contact closure to indicate when the traffic signal is operating on battery supply.

The UPS control unit shall have an open collector output or an AC or DC contact closure to indicate low battery alarm.

The UPS control unit shall have a minimum of 1 switched AC output that will switch on when the traffic signal has been on battery supply continuously for 4 hours.



A 9 pin male serial port shall be located on the front panel to allow for communication to a laptop computer for changing software settings.

A set of battery voltage test points, or a readout indicating battery voltage condition shall be located on the front panel.

### **1.5 UPS Automatic Switch**

The UPS automatic switch shall allow the UPS control unit to be removed for replacement or maintenance without turning off the traffic signal system.

The utility line power shall be connected to the input of the automatic switch. Under normal operating conditions the automatic switch shall connect the utility line power to the UPS control unit. In the event that the UPS control unit is not present or does not function, the automatic switch shall automatically connect the utility line power directly to the traffic signal system, bypassing the UPS control unit.

The switch shall also allow for transferring power to an external receptacle for portable generator powering of the traffic controller during extended periods of power loss.

### **1.6 Power Conditioning and the Use of Batteries by the UPS**

Under normal operating conditions the utility line power shall flow through the UPS control unit to the traffic signal system and any other connected loads.

When the utility line power is within the operating parameters specified by the UPS manufacturer and the Contract Documents the UPS control unit shall condition and deliver the power to the loads without drawing power from the batteries.

When the utility line power is not within the operating parameters specified by the UPS manufacturer and the Contract Documents the UPS control unit shall condition and deliver the power to the loads by drawing power from the batteries as required.

### **5.7 Electrical**

The UPS system shall accept an AC voltage input range of 85 to 135 VAC, single phase, 2 wire plus ground without drawing on battery power.

The UPS system shall provide voltage regulation at 120 VAC  $\pm$  3 percent under any line, load or battery conditions other than "low battery", and a frequency regulation of 60 Hz  $\pm$  3 Hz synchronized to the utility line power.

Power rating shall be a minimum of 1000 VA (700W). The UPS system shall provide pure sine wave output, computer grade power compatible with all equipment loads, with power factor correction.

The UPS system shall include full time protection from sudden voltage increase with inrush protection and AC line filtering.

The UPS system shall provide complete isolation from the line operating as a separately derived power source in accordance with NEC requirements.

Duct seal compound is to be used to adequately seal all duct ends inside the cabinet.

All cables entering into the UPS shall be labeled using a permanent marking system to the satisfaction of the Town.

The Contractor shall coordinate turn-on with the Town.

### **1.7 PRODUCTION**

All wires and leads shall be tied and secured within the UPS cabinet prior to delivery.

### **1.8 BASIS OF PAYMENT**

The unit price identified in the schedule of unit prices shall be full compensation to Supply and Install a Battery Backup System or UPS for the traffic signal system. The unit price bid shall also include but not limited to Alpha Novus FXM with 1100 W/VA output, Alpha Outdoor Enclosure Side Mount 6, Universal Automatic Transfer Switch, AlphaGuard Battery Balancer, Battery heater mats, Surge Suppression device, Generator support, locking generator access door and L5-30 F1 plug, Universal Generator Transfer switch, On Battery indicator light, door activated interior light, tilt switch, Tamper switch, ground mount kit, and 4 – GXL 210 AlphaCell Batteries or approved equivalent. UPS equipment shall be installed in accordance with manufacturer's specifications.

**ITEM # 1118012A    REMOVAL AND/OR RELOCATION OF TRAFFIC SIGNAL EQUIPMENT**

Section 11.18: Replace the entire section with the following:

**11.18.01 – Description:**

Remove all abandon traffic signal equipment. Restore the affected area. Where indicated on the plans remove and reinstall existing traffic signal equipment to the location(s) shown.

**11.18.02 – Materials:**

The related sections of the following specifications apply to all incidental and additional material required for the proper relocation of existing equipment and the restoration of any area affected by this work.

- Division III, “Materials Section” of the Standard Specifications.
- Current Supplemental Specifications to the Standard Specifications.
- Applicable Special Provisions to the Standard Specifications.
- Current Department of Transportation, Functional Specifications for Traffic Control Equipment.

**Article 11.18.03 - Construction Methods:**

Schedule/coordinate the removal and/or relocation of existing traffic signal equipment with the installation of new equipment to maintain uninterrupted traffic signal control. This includes but is not limited to vehicle signals and detectors, pedestrian signals and pushbuttons, co-ordination, and pre-emption.

Abandoned Equipment

The contract traffic signal plan usually does not show existing equipment that will be abandoned. Consult the existing traffic signal plan for the location of abandoned material especially messenger strand, conduit risers, and handholes that are a distance from the intersection. A copy of the existing plan is usually in the existing controller cabinet. If not, a plan is available from the Division of Traffic Engineering upon request.

Unless shown on the plans it is not necessary to remove abandoned conduit in-trench and conduit under-roadway

When a traffic signal support strand, rigid metal conduit, down guy, or other traffic signal equipment is attached to a utility pole, secure from the pole custodian permission to work on the pole. All applicable Public Utility Regulatory Authority (PURA) regulations and utility company requirements govern. Keep utility company apprised of the schedule and the nature of the work. Remove all abandoned hardware, conduit risers, and down guys, Remove anchor rods, to 6” (150mm) below grade.

When underground material is removed, backfill the excavation with clean fill material. Compact the fill to eliminate settling. Remove entirely the following material: pedestal foundation; controller foundation; handhole; pressure sensitive vehicle detector complete with concrete base. Unless otherwise shown on the

plan, remove steel pole and mast arm foundation to a depth of 2 feet (600mm) below grade. Restore the excavated area to a grade and condition compatible with the surrounding area.

- If in an unpaved area apply topsoil and establish turf in accordance with Section 9.44 and Section 9.50 of the Standard Specifications.
- If in pavement or sidewalk, restore the excavated area in compliance with the applicable Sections of Division II, "Construction Details" of the Standard Specifications.

Relocated Equipment

In the presence of the Engineer, verify the condition of all material that will be relocated and reused at the site. Carefully remove all material, fittings, and attachments in a manner to safeguard parts from damage or loss. Replace at no additional cost, all material which becomes damaged or lost during removal, storage, or reinstallation.

Salvage Equipment

Salvage Material	Stock No.	Value
Controller Cabinet, Complete including but not limited to the following: Conflict Monitor Coordination Equipment Vehicle Detection Equipment	330-03-7010	\$ 500.00
Controller Unit	330-03-7005	\$ 500.00
Aluminum Pedestal 8 foot (2.4 m)	330-16-7108	\$ 100.00
4 foot, 4 inch (1.3 m)	330-16-7112	\$ 100.00
Steel Span Pole, 30' (9.0 m)	330-16-7050	\$ 250.00
Steel Span Pole, all other lengths	330-16-7016	\$ 250.00

All material not listed as salvage becomes the property of the Contractor. Properly handle, transport, then dispose in a suitable dump or recycle this material. Comply with all Federal and State hazardous waste laws and regulations.

In the presence of the Engineer, verify the condition and quantity of salvage material prior to removal. After removal transport and store the material protected from moisture, dirt, and other damage. Coil and secure copper cable separate from other cable such as galvanized support strand.

Within 4 working days of removal, return the Town owned salvage material to the Department of Public Works. Supply all necessary manpower and equipment to load, transport, and unload the material. The condition and quantity of the material after unloading will be verified by the Engineer.

Contact Town Engineer at least 24 hours prior to delivery.

Municipal Owned Traffic Signal Equipment

Return all municipal owned material such as pre-emption equipment to the Town.

**Article 11.18.04 – Method of Measurement:**

This work will be measured as a Lump Sum.

**Article 11.18.05 – Basis of Payment:**

This work will be paid for at the contract lump sum price for “Removal and/or Relocation of Traffic Signal Equipment” which price shall include relocating signal equipment and associated hardware, all equipment, material, tools and labor incidental thereto. This price shall also include removing, loading, transporting, and unloading of signal equipment/materials designated for salvage and all equipment, material, tools and labor incidental thereto. This price shall also include removing and disposing of traffic signal equipment not to be salvaged and all equipment, material, tools and labor incidental thereto.

Payment is at the contract lump sum price for “Removal and/or Relocation of Traffic Signal Equipment” inclusive of all labor, vehicle usage, storage, and incidental material necessary for the complete removal of abandoned equipment/material and/or relocation of existing traffic signal equipment/material. Payment will also include the necessary labor, equipment, and material for the complete restoration of all affected areas.

A credit will be calculated and deducted from monies due the Contractor equal to the listed value of salvage material not returned or that has been damaged and deemed unsalvageable due to the Contractor’s operations.

**ITEM # 1118051A                      TEMPORARY SIGNALIZATION (SITE NO. 1)**

**Description:**

The Contractor shall keep the traffic signal completely operational at all times during construction through the use of existing signal equipment, temporary signal equipment, new signal equipment, or any combination thereof once TS has started as noted in the section labeled Duration.

**Materials:**

- Pertinent articles of the Standard Specifications
- Supplemental Specifications and Special Provisions contained in this contract

**Construction Methods:**

Preliminary Inspection

In the presence of the Engineer and a representative from Town, inspect and document the existing traffic signal's physical and operational condition prior to Temporary Signalization. Include but do not limit the inspection to the following:

- Controller Assembly (CA)
  - Controller Unit (CU)
  - Detection Equipment
  - Pre-emption Equipment
  - Coordination Equipment
- Vehicle and Pedestrian Signals
- Vehicle and Pedestrian Detectors
- Emergency Vehicle Pre-emption System (EVPS) \*
- Interconnect Cable and Splice Enclosures
- Support Structures
- Handholes, Conduit and Cable

It may be necessary to repair or replace equipment that is missing, damaged, or malfunctioning. Develop a checklist of items for replacement or repair after the inspection. If authorized by the Engineer, this work will be considered "Extra Work" under Article 1.09.04.

\* At a State owned signal the EVPS equipment is usually owned by the municipality. It is recommended to apprise the municipality of the inspection schedule and results.

TS Plan

At least 30 days prior to implementation of each stage, submit a 1:40 scale TS plan for each location to the Engineer for review and comment. Include but do not limit the plan to the following:

- Survey Ties
- Dimensions of Lanes, Shoulders, and Islands
- Slope Limits
- Clearing and Grubbing Limits
- Signal Phasing and Timing
- Location of Signal Appurtenances such as Supports, Signal Heads, Pedestrian Push buttons, Pedestrian Signals
- Location of Signing and Pavement Markings (stop bars, lane lines, etc.)
- Location, method, and mode of Temporary Detection

Review of the TS plan does not relieve the Contractor of ensuring the TS meets the requirements of the MUTCD. A copy of the existing traffic signal plan for State-owned traffic signals is available from the Division of Traffic Engineering upon request. Request existing traffic signal plans for Town-owned traffic signals from the Town. Do not implement the TS plan until all review comments have been addressed.

Earthwork

Perform the necessary clearing and grubbing and the grading of slopes required for the installation, maintenance, and removal of the TS equipment. After TS terminates restore the affected area to the prior condition and to the satisfaction of the Engineer.

Maintenance and Protection of Traffic

Furnish, install, maintain, relocate, and remove signal-related signing (lane-use, signal ahead, NTOR, etc.) and pavement markings as needed. Install, relocate, and/or remove equipment in a manner to cause no hazard to pedestrians, traffic or property. Maintain traffic as specified in the Special Provisions "Prosecution and Progress" and "Maintenance and Protection of Traffic."

Electrical Service and Telephone Service at Existing Signalized Intersections

If the electrical service or the telephone service source must be changed or relocated make all arrangements with the utility company and assume all charges. The party previously responsible for the monthly payment of service shall continue to be responsible during TS.

Temporary Signalization

Furnish, install, maintain, relocate, and remove existing, temporary, and proposed traffic signal equipment and all necessary hardware; modify or furnish a new CA; reprogram the CU phasing and timing; as many times as necessary for each stage/phase of construction to maintain and protect traffic and pedestrian movements as shown on the plans or as directed by the Engineer.

Inspection

When requested by the Engineer, the TS will be subject to a field review by a representative of the Division of Traffic Engineering and/or the Town, which may generate additional comments requiring revisions to the temporary signal.

Detection

Provide vehicle detection on the existing, temporary, and/or new roadway alignment for all intersection approaches that have existing detection, that have detection in the final condition as shown on the signal plan, or as directed by the Engineer. Keep existing pedestrian pushbuttons accessible and operational at all times during TS.

Emergency Vehicle Pre-emption System (EVPS)

Furnish, install, maintain, relocate, and remove the equipment necessary to keep the existing EVPS operational as shown on the plan. Do not disconnect or alter the EVPS without the knowledge and concurrence of the Engineer and the EVPS owner. Schedule all EVPS relocations so that the system is out of service only when the Contractor is actively working. Ensure EVPS is returned to service and is completely operational at the end of the work day. Keep the EVPS owner apprised of all changes to the EVPS.

Coordination

Furnish, install, maintain, relocate, and remove the equipment necessary to keep the intersection coordinated to adjacent signals as shown on the plan. Do not disconnect the interconnect without the approval of the Engineer.

- Closed Loop System: If it is necessary to disconnect the communication cable, notify the Engineer and the Bridgeport Operation Center (BOC) or the Newington Operation Center (NOC) prior to disconnect and also after it is reconnected.

Maintenance

Once TS is in effect, assume maintenance responsibilities of the entire installation. Notify the Engineer for the project records the date that Temporary Signalization begins. Notify the following parties that maintenance responsibility has been transferred to the Contractor:

Town Engineer  
Local Police Department

Provide the Engineer a list of telephone numbers of personnel who will be on-call during TS. Respond to traffic signal malfunctions by having a representative at the site within three hours from the initial contact. Within twenty-four (24) hours have the traffic signal operating according to plan.

If the Engineer determines that the nature of a malfunction requires immediate attention and/or the Contractor does not respond within three (3) hours, then an alternate maintenance service will be called to repair the signal. Expenses incurred by the alternate maintenance service for each call will be deducted from monies due to the Contractor with a minimum deduction of \$1,000. The alternate maintenance service may be the owner of the signal or another qualified electrical contractor.

Duration

Temporary Signalization shall commence when any existing signal equipment is disturbed, relocated, or altered based on the inspection checklist in any way for the TS.

Ownership

Existing equipment, designated as salvage, remains the property of the owner. Salvable equipment will be removed and delivered to the owner upon completion of use. Temporary equipment supplied by the Contractor remains the Contractor's property unless noted otherwise.

**Method of Measurement:**

Temporary Signalization shall be paid only once per site on a percentage of the contract Lump Sum price. Fifty percent (50%) shall be paid when TS is operational as shown on the plan or to the satisfaction of the Engineer. Fifty percent (50%) shall be paid when TS terminates.

**Basis of Payment:**

This work shall be paid at the contract Lump Sum price for "Temporary Signalization (Site No. 1)." This price includes the preliminary inspection, TS plan for each stage/phase, furnishing, installing, maintaining, relocating and revising traffic signal equipment, controller assembly modifications, controller unit program changes such as phasing and timing, removing existing, temporary, and proposed traffic signal equipment, arrangements with utility companies, towns or cities including the fees necessary for electric and telephone service, clearing and grubbing, grading, area restoration and all necessary hardware, materials, labor, and work incidental thereto.

All material and work for signing and pavement markings is paid for under the appropriate Contract items.

All Contractor supplied items that will remain the Contractor's property shall be included in the contract Lump Sum price for "Temporary Signalization."

Any items installed as part of the permanent installation are not paid for under this item but are paid for under the bid item for that work.



**ITEM # 1206023A    REMOVAL AND RELOCATION OF EXISTING SIGNS**

Section 12.06 is supplemented as follows:

Article 12.06.01 – Description is supplemented with the following:

Work under this item shall consist of the removal and/or relocation of designated side-mounted sheet aluminum signs, sign posts, sign supports, and foundations where indicated on the plans or as directed by the Engineer. Work under this item shall also include furnishing and installing new sign posts and associated hardware for signs designated for relocation.

Article 12.06.03 – Construction Methods is supplemented with the following:

The Contractor shall take care during the removal and relocation of existing signs that are to be relocated so that they are not damaged. Any material that is damaged shall be replaced by the Contractor at no additional cost.

Materials designated for removal shall be removed and disposed of by the Contractor as directed by the Engineer and in accordance with existing standards for Removal of Existing Signing.

Sheet aluminum signs designated for relocation are to be re-installed on new sign posts.

Article 12.06.04 – Method of Measurement is supplemented with the following:

Payment under Removal and Relocation of Existing Signs shall be at the contract lump sum price which shall include all sheet aluminum signs designated for relocation, all new sign posts and associated hardware for signs designated for relocation, all sheet aluminum signs, sign posts and sign supports designated for scrap, and foundations and other materials designated for removal and disposal, and all work and equipment required.

Article 12.06.05 – Basis of Payment is supplemented with the following:

This work will be paid for at the contract lump sum price for “Removal and Relocation of Existing Signs” which price shall include relocating designated sheet aluminum signs, providing new posts and associated hardware for relocated signs, removing and disposing of foundations and other materials, and all equipment, material, tools and labor incidental thereto. This price shall also include removing, loading, transporting, and unloading sheet aluminum signs, sign posts, and sign supports designated for scrap and all equipment, material, tools and labor incidental thereto.

**ITEM # 1208928A SIGN FACE SHEET ALUMINUM (TYPE III REFLECTIVE SHEETING)**

Description: This item shall consist of furnishing and installing sign face-sheet aluminum signs of the type specified, metal sign posts, mast arm-mounted sign brackets at locations indicated on the plans or as ordered and in conformance with the plans and these specifications.

All traffic and parking signs shall conform to the latest revision of the "Manual on Uniform Traffic Control Devices" conventional road size, the "Standard Highway Signs" book and the "Connecticut Department of Transportation Catalog of Signs".

This item shall also include the installation of Town of Glastonbury Street Name signs on the mast arms as shown on the plans.

Materials:

Reflective sheeting shall conform to the requirements of Article M.18.09.01, Type III.

Sheet aluminum sign blanks shall be 0.08 inches thick and conform to the requirements of Article M.18.13.

Silk screening of Type III reflective sheeting shall conform to the requirements specified by the reflective sheeting manufacturer.

Metal sign posts sign supports shall meet the requirements of the Connecticut Department of Transportation galvanized Type II, 3 lbs/ft breakaway channel posts and conform to the requirements of Article M.18.14.

Sign mounting bolts shall conform to the requirements of Article M.18.15.

The Town street name signs at the locations shown on the plans are 18" tall by a length appropriate for the size of street name with 8" white reflective letters and a 1/2" white reflective border and reflective sheeting. The street name sign sheeting is 3m high intensity prismatic sheeting, white and a color to be determined by the Town.

The street name signs shall list the text of the street name in capital letters, with the street/road/boulevard abbreviated as necessary and in small capitals. The Town of Glastonbury Town Seal shall be shown on the sign face as well.

The color of the street name signs will be determined by the Town during the shop drawing review process.

Construction Methods: Placement and dimensions of copy, border and mounting holes shall conform to details of the Department of Transportation for Regulatory Warning and Guide signs which are available for inspection at the Department of Transportation office. Non-reflective copy, border and background shall be applied by the silk-screen process in a manner specified by the reflective sheeting manufacturer. The silk screening of all copy, border and background on Type III reflective sheeting shall be accomplished prior to the application of the reflective sheeting to the finished aluminum sign blank. Type III reflective sheeting shall be of the heat activated adhesive type and shall be applied in a manner specified by the reflective sheeting manufacturer.

Reflective sheeting shall be applied in such a manner that the finished sign will be wrinkle and bubble free. No splices of the reflective sheeting will be permitted on any sign face under 30 square feet (2.7 square

meters) in area with one dimension of 4 feet (1.2 meters) or less and no more than one splice will be permitted on any one sign without the approval of the Engineer.

Direct application of cutout Type III reflective sheeting copy and border shall conform to the requirements specified by the reflective sheeting manufacturer. Cutout copy and border shall be applied directly to clean, dust free reflective sheeting background panels. Borders shall be cut neatly and butt-joined at corners and panel joints. Type I or Type II reflective sheeting used for direct applied cutout copy and border shall be uniform in brightness and color.

The fabrication of aluminum sign blanks including cutting to size and shape and the punching of mounting holes shall be completed prior to metal degreasing and the application of reflective sheeting. Aluminum sign blanks shall be free of buckles, warp, dents, cockles, burrs and defects resulting from fabrication. Mast arm-mounted sign brackets shall be installed as shown on the plans.

After complete fabrication of the sign as indicated on the plans and in conformance with the requirements contained in the specifications, the sign shall be mounted on the type of support indicated on the plans after the support has been satisfactorily installed at its proper location. The reinforcing plate shall be installed as shown on the plans.

Metal sign posts shall be driven or the holes augered and the backfill thoroughly tamped after the posts have been set level and plumb. Parapet and mast arm mounted sign supports shall be installed as shown on the plans and shall be level and plumb.

The Contractor shall submit the templates for the street name signs for review and approval prior to ordering the signs.

Method of Measurement: This work will be measured for payment by the number of square feet of sign face-sheet aluminum of the type specified, installed and accepted.

Basis of Payment: This work will be paid for at the Contract unit price per square foot for "Sign Face-Sheet Aluminum" of the type specified complete in place, which price shall include the completed sign, metal sign post(s), mast arm-mounted brackets, Town seal placement on street name signs, mounting hardware, including reinforcing plates, and all materials, equipment, labor and work incidental thereto.

**ITEM # 1210101A 4" WHITE EPOXY RESIN PAVEMENT MARKINGS**

**ITEM # 1210102A 4" YELLOW EPOXY RESIN PAVEMENT MARKINGS**

**ITEM # 1210105A EPOXY RESIN PAVEMENT MARKINGS, SYMBOLS AND LEGENDS**

This item shall conform to Section 12.10 EPOXY RESIN PAVEMENT MARKINGS, SYMBOLS AND LEGENDS, CONNECTICUT SUPPLEMENTAL SPECIFICATION and Section 12.11 REMOVAL OF PAVEMENT MARKINGS, of the Form 816 amended as follows:

Delete "SYMBOLS AND LEGENDS" from the title of the special provision.

Construction Methods:

Section 12.10.03 Construction Methods of the Form 816 is amended as follows:

Delete the entire section titled "WARRANTY" under item number 3. Performance and Warranty.

It was determined by the Office of Construction that the First Year warranty requirement is not necessary because early test results generally depict the outcome of pavement markings.

Section 12.11.04 of the Form 816 shall be amended to read, "The work of removing existing pavement markings shall not be measured for payment."

Section 12.11.05 shall be amended to read "There will be no separate payment for this item." All of the work of removing existing pavement markings shall be included in the unit prices for pavement markings or other items associated thereto.

**ITEM # 1220013A CONSTRUCTION SIGNS – BRIGHT FLUORESCENT SHEETING**

General: The Contractor shall furnish construction signs with bright fluorescent sheeting and their required portable supports or metal sign posts that conform to the requirements of NCHRP Report 350 (TL-3). The construction signs and their required portable supports or metal sign posts shall conform to the signing requirements stated in Article 9.71 "Maintenance and Protection of Traffic", as shown on the plans and/or as directed by the Engineer.

Materials: Prior to using the construction signs and their portable supports, the Contractor shall submit to the Engineer a copy of the Letter of Acceptance issued by the FHWA to the manufacturer documenting that the devices (both sign and portable support tested together) conform to NCHRP Report 350 (TL-3).

Portable sign supports shall be designed and fabricated so as to prevent signs from being blown over or displaced by the wind from passing vehicles. Portable sign supports shall be approved by the Engineer before they are used. Mounting height of signs on portable sign supports shall be a minimum of 1 foot and a maximum of 2 feet, measured from the pavement to the bottom of the sign.

All sign faces shall be rigid and reflectorized. Sheet aluminum sign blanks shall conform to the requirements of Article M.18.13. Metal sign posts shall conform to the requirements of Article M.18.14. Application of reflective sheeting, legends, symbols, and borders shall conform to the requirements specified by the reflective sheeting manufacturer. Attachments shall be provided so that the signs can be firmly attached to the portable sign supports or metal posts without causing damage to the signs. A Materials Certificate and Certified Test Report conforming to Article 1.06.07 shall be required for the reflective sheeting.

The following types of construction signs shall not be used: mesh, non-rigid, roll-up, corrugated or waffle board types substrates, foam core and composite aluminum sign substrates.

Reflective sheeting shall conform to the following:

The fluorescent orange prismatic retroreflective sheeting shall consist of prismatic lenses formed in a transparent fluorescent orange synthetic resin, sealed, and backed with an aggressive pressure sensitive adhesive protected by a removable liner. The sheeting shall have a smooth surface.

Physical Properties:

A. Photometric - Coefficient of Retroreflection  $R_A$

When the sheeting applied on test panels is measured in accordance with ASTM E 810, it shall have minimum coefficient of retroreflection values as shown in Table I. The rotation angle shall be as designated by the manufacturer for test purposes, the observation angles shall be 0.2 degrees and 0.5 degrees, the entrance angles (component B1) shall be -4 degrees and +30 degrees.

TABLE I  
Minimum Coefficient of Retroreflection  $R_A$   
Candelas per footcandle per square foot

Observation Angle (deg.)	Entrance Angle (deg.)	$R_A$ Orange
0.2	- 4	200
0.2	+ 30	90
0.5	- 4	80
0.5	+ 30	50

The rotation shall be as designated by the manufacturer.

**B. Daytime Color**

Color shall conform to the requirements of Table II. Daytime color and maximum spectral radiance factor (peak reflectance) of sheeting mounted on test panels shall be determined instrumentally in accordance with ASTM E 991. The values shall be determined on a Hunter Lab Labscan 6000 0/45 Spectrocolorimeter with option CMR 559 (or approved equal 0/45 instrument with circumferential viewing illumination). Computations shall be done in accordance with ASTM E 308 for the 2 degree observer.

TABLE II  
Color Specification Limits\*\* (Daytime)

Color	1		2		3		4		Reflectance Limit Y (%)	
	X	Y	X	Y	X	Y	X	Y	MIN	MAX
<b>Orange</b> (new)	.583	.416	.523	.397	.560	.360	.631	.369	28	-
<b>Orange</b> (weathered)	.583	.416	.523	.397	.560	.360	.631	.369	20	45

Maximum Spectral Radiance Factor, new: 110%, min.  
weathered: 60%, min.

\*\* The four pairs of chromaticity coordinates determine the acceptable color in terms of the CIE 1931 standard colorimetric system measured with standard illuminant D65.

**C. Nighttime Color**

Nighttime color of the sheeting applied to test panels shall be determined instrumentally in accordance with ASTM E 811 and calculated in the u', v' coordinate system in accordance with ASTM E 308. Sheeting shall be measured at 0.33 degrees observation and -4 degree entrance at rotation as determined by the manufacturer for test purposes. Color shall conform to the requirements of Table III.

TABLE III  
Color Specification Limits \*\* (Nighttime)

Color	1		2		3		4	
	u'	v'	u'	v'	u'	v'	u'	v'
Orange (new and weathered)	.400	.540	.475	.529	.448	.522	.372	.534

**D. Resistance to Accelerated Weathering**

The retroreflective surface of the sheeting shall be weather resistant and show no appreciable cracking, blistering, crazing, or dimensional change after one year's unprotected outdoor exposure in south Florida, south-facing and inclined 45 degrees from the vertical, or after 1500 hours exposure in a xenon arc weatherometer in accordance with ASTM G26, Type B, Method A. Following exposure, panels shall be washed in a 5% HCL solution for 45 seconds, rinsed thoroughly with clean water, blotted with a soft clean cloth and brought to equilibrium at standard conditions. After cleaning, the coefficient of retroreflection shall be not less than 100 when measured as in D.2, below, and the color is expected to conform to the requirements of Tables II and III for weathered sheeting. The sample shall:

1. Show no appreciable evidence of cracking, scaling, pitting, blistering, edge lifting or curling or more than 0.031 inch shrinkage or expansion.
2. Be measured only at angles of 0.2 degrees observation, -4 degrees entrance, and rotation as determined by the manufacturer for test purposes. Where more than one panel of color is measured, the coefficient of retroreflection shall be the average of all determinations.

**E. Impact Resistance**

The retroreflective sheeting applied according to the manufacturer's recommendations to a test panel of alloy 6061-T6, 0.040 inch by 3 inches by 5 inches and conditioned for 24 hours, shall show no cracking outside the impact area when the face of the panel is subjected to an impact of 100 inch-pounds, using a weight with a 0.625 inch diameter rounded tip dropped from a height necessary to generate an impact of 100 inch-pounds, at test temperatures of both 32° F and 72° F.

**F. Resistance to Heat**

The retroreflective sheeting, applied to a test panel as in E., above, and conditioned for 24 hours, shall be measured in accordance with Paragraph A. at 0.2 degree observation and -4 degree entrance angles at rotation as determined by the manufacturer for test purposes and exposed to 170° ± 5° F for 24 hours in an air circulating oven. After heat exposure the sheeting shall retain a minimum of 70% of the original coefficient of retroreflection.

**G. Field Performance:**

Retroreflective sheeting processed and applied to sign blank materials in accordance with the sheeting manufacturer's recommendations, shall perform effectively for a minimum of 3 years. The retroreflective sheeting will be considered unsatisfactory if it has deteriorated due to natural causes to the extent that: (1) the sign is ineffective for its intended purpose when viewed from a moving vehicle under normal day and night driving conditions; or (2) the coefficient of retroreflection is less than 100 when measured at 0.2 degrees observation and -4 degree entrance. All measurements shall be made after sign cleaning according to the sheeting manufacturer's recommendations.

Construction Methods: Ineffective signs, as determined by the Engineer and in accordance with the ATSSA guidelines contained in "Quality Standards for Work Zone Traffic Control Devices", shall be replaced by the Contractor at no cost to the State.

Signs and their portable sign supports or metal posts that are no longer required shall be removed from the project and shall remain the property of the Contractor.

Method of Measurement: Construction Signs - Bright Fluorescent Sheeting will be measured for payment by the number of square feet of sign face. Sign supports will not be measured for payment.

Basis of Payment: "Construction Signs - Bright Fluorescent Sheeting" required and used on the project will be paid for at the Contact unit price per square foot as listed in the bid proposal. This price shall include the furnishing and maintenance of the signs, portable sign supports, metal sign posts and all hardware. Each sign and support or posts will be paid for once, regardless of the number of times it is used.

**ITEM # 1302060A                      ADJUST GATE BOX (GAS)**

Description: This work consists of adjusting existing gas gate boxes to new grades indicated on the Plans or as directed by the Engineer, all in accordance with these Specifications. Adjustment of gas gate boxes shall be performed under the direct supervision of Connecticut Natural Gas (CNG) personnel. The contractor shall contact John Bonville of CNG at 860-982-3815 a minimum of 48 hours prior to his anticipated date that this work is to be performed.

Materials: Any materials required for the adjustment of boxes shall conform to the applicable section of the Form 816 or the specification of CNG.

Construction Methods: Gas gate boxes shall be carefully loosened from the surrounding material and adjusted to the designated new grades. The Contractor shall then carefully place approved granular material around the gate boxes and hand tamp this material until it is well compacted.

The Contractor must maintain access to the gate boxes at all times. If a gas gate box is damaged due to improper construction methods, the Contractor shall replace the damaged unit with the corresponding new unit at no additional cost to the Town.

Method of Measurement: "Adjust Gas Gate Boxes" will be measured by the number of such units actually adjusted in accordance with the Plans and/or as directed by the Engineer.

Basis of Payment: The accepted quantities of "Adjust Gate Box (Gas)" will be paid for at the contract unit price per each as listed in the Proposal. Each and every adjustment authorized by the Engineer will be paid for. The price shall constitute full and complete compensation for all labor, materials, and equipment including excavation, backfill, compaction, adapter collar and for all other incidentals required to finish the work, complete and accepted by both the Engineer and the representative of the particular utility company involved.



**ITEM # 1302061A                      ADJUST GATE BOX (WATER)**

Description: Reference to the "District" in this item refers to "The Metropolitan District".

The Contractor shall adjust to final grade, the gate boxes and covers appurtenant to the water mains as required and furnish and install extension rings, extension stems, air valve extensions, covers, and additional top or bottom sections if necessary, as shown on the Contract Drawings or as directed by the Engineer in accordance with these specifications.

The District shall be contacted a minimum of 48 hours prior to initiating the adjustment of any water gate boxes so that an inspector can be provided for this work. The Contractor shall contact Mr. Rich Norris at (860) 278-7850 extension 3450 to arrange an inspector for this work.

Materials: The Contractor shall furnish standard District cast iron Dwyer type gate box sections as required and extension stems if necessary.

All additional materials, including any resurfacing materials and any additional fill required, shall be furnished and placed by the Contractor. Gravel shall conform to Article M.02.01.

Construction Methods: The Contractor shall carefully excavate around the gate boxes, remove the boxes, install extension stems and air valve extensions, if necessary, reinstall the present gate box if reusable, adjust the box to final grade using extension rings if applicable, and refill the excavation. Care shall be taken to prevent material from filling the inside of the gate box.

Extension stems will be required if the gate box is raised 24-inches or more. Extension stems shall be fabricated according to the detail shown on sheet WS-25 of the District's "Developers Manual."

Any damage done to District facilities by the Contractor shall be repaired or replaced by the Contractor at his expense.

Method of Measurement: The number of adjust gate boxes, complete with extension stems, air valve extensions, gate box extension rings, covers, and additional top or bottom sections, if necessary, measured for payment shall be the actual number of each box reset.

Basis of Payment: This work will be paid for at the contract unit price listed in the bid proposal for "Adjust Gate Box" complete in place, which price shall include the cost of furnishing material, including labor and equipment to incorporate them into the work. It shall also include the clearing, trenching and disposal of excavated materials, refilling trenches, furnishing the additional material for refilling, grading, sheeting, bracing, and pumping.

ATTACHMENT A: PREVAILING WAGE INFORMATION

## ~NOTICE~

### TO ALL CONTRACTING AGENCIES

Please be advised that Connecticut General Statutes Section 31-53, requires the contracting agency to certify to the Department of Labor, the total dollar amount of work to be done in connection with such public works project, regardless of whether such project consists of one or more contracts.

Please find the attached “Contracting Agency Certification Form” to be completed and returned to the Department of Labor, Wage and Workplace Standards Division, Public Contract Compliance Unit.

 Inquiries can be directed to (860)263-6543.

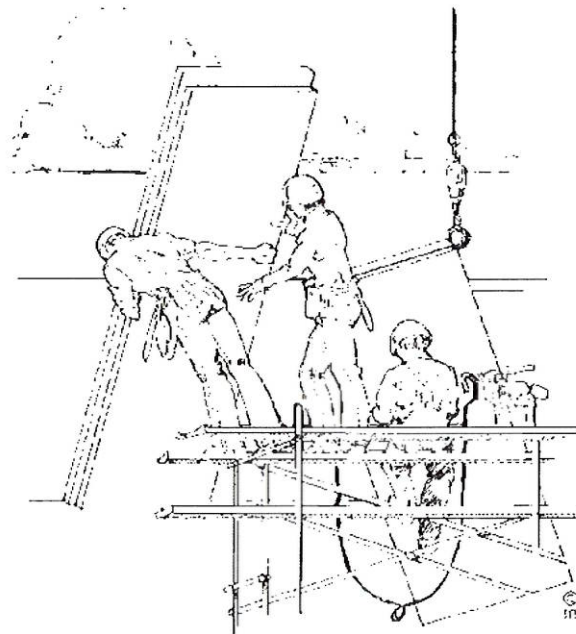

CONNECTICUT DEPARTMENT OF LABOR  
WAGE AND WORKPLACE STANDARDS DIVISION  
CONTRACT COMPLIANCE UNIT

*CONTRACTING AGENCY CERTIFICATION FORM*

I, \_\_\_\_\_, acting in my official capacity as \_\_\_\_\_,  
authorized representative title

for \_\_\_\_\_, located at \_\_\_\_\_,  
contracting agency address

do hereby certify that the total dollar amount of work to be done in connection with

\_\_\_\_\_, located at \_\_\_\_\_,  
project name and number address

shall be \$ \_\_\_\_\_, which includes all work, regardless of whether such project  
consists of one or more contracts.

*CONTRACTOR INFORMATION*

Name: \_\_\_\_\_

Address: \_\_\_\_\_

Authorized Representative: \_\_\_\_\_

Approximate Starting Date: \_\_\_\_\_

Approximate Completion Date: \_\_\_\_\_

\_\_\_\_\_  
Signature

\_\_\_\_\_  
Date

Return To: Connecticut Department of Labor  
Wage & Workplace Standards Division  
Contract Compliance Unit  
200 Folly Brook Blvd.  
Wethersfield, CT 06109

Date Issued: \_\_\_\_\_

# Statute 31-55a

Last Updated: April 22, 2010

You are here: [DOL Web Site](#) » [Wage and Workplace Standards](#) » Statute 31-55a

## - Special Notice -

To All State and Political Subdivisions, Their Agents, and Contractors

**Connecticut General Statute 31-55a - Annual adjustments to wage rates by contractors doing state work.**

*Each contractor that is awarded a contract on or after October 1, 2002, for (1) the construction of a state highway or bridge that falls under the provisions of section 31-54 of the general statutes, or (2) the construction, remodeling, refinishing, refurbishing, rehabilitation, alteration or repair of any public works project that falls under the provisions of section 31-53 of the general statutes shall contact the Labor Commissioner on or before July first of each year, for the duration of such contract, to ascertain the prevailing rate of wages on an hourly basis and the amount of payment or contributions paid or payable on behalf of each mechanic, laborer or worker employed upon the work contracted to be done, and shall make any necessary adjustments to such prevailing rate of wages and such payment or contributions paid or payable on behalf of each such employee, effective each July first.*

- The prevailing wage rates applicable to any contract or subcontract awarded on or after October 1, 2002 are subject to annual adjustments each July 1st for the duration of any project which was originally advertised for bids on or after October 1, 2002.
- Each contractor affected by the above requirement shall pay the annual adjusted prevailing wage rate that is in effect each July 1st, as posted by the Department of Labor.
- It is the **contractor's** responsibility to obtain the annual adjusted prevailing wage rate increases directly from the Department of Labor's Web Site. The annual adjustments will be posted on the Department of Labor Web page: [www.ctdol.state.ct.us](http://www.ctdol.state.ct.us). For those without internet access, please contact the division listed below.
- The Department of Labor will continue to issue the initial prevailing wage rate schedule to the Contracting Agency for the project. All subsequent annual adjustments will be posted on our Web Site for contractor access.

**Any questions should be directed to the Contract Compliance Unit, Wage and Workplace Standards Division, Connecticut Department of Labor, 200 Folly Brook Blvd., Wethersfield, CT 06109 at (860)263-6790.**

←-- [Workplace Laws](#)

Published by the Connecticut Department of Labor, Project Management Office



# **Informational Bulletin**

## **THE 10-HOUR OSHA CONSTRUCTION SAFETY AND HEALTH COURSE**

(applicable to public building contracts entered into *on or after July 1, 2007*, where the total cost of all work to be performed is at least \$100,000)

- (1) This requirement was created by Public Act No. 06-175, which is codified in Section 31-53b of the Connecticut General Statutes (pertaining to the prevailing wage statutes);
- (2) The course is required for public building construction contracts (projects funded in whole or in part by the state or any political subdivision of the state) entered into on or after July 1, 2007;
- (3) It is required of private employees (not state or municipal employees) and apprentices who perform manual labor for a general contractor or subcontractor on a public building project where the total cost of all work to be performed is at least \$100,000;
- (4) The ten-hour construction course pertains to the ten-hour Outreach Course conducted in accordance with federal OSHA Training Institute standards, and, for telecommunications workers, a ten-hour training course conducted in accordance with federal OSHA standard, 29 CFR 1910.268;
- (5) The internet website for the federal OSHA Training Institute is [http://www.osha.gov/fso/ote/training/edcenters/fact\\_sheet.html](http://www.osha.gov/fso/ote/training/edcenters/fact_sheet.html);
- (6) The statutory language leaves it to the contractor and its employees to determine who pays for the cost of the ten-hour Outreach Course;
- (7) Within 30 days of receiving a contract award, a general contractor must furnish proof to the Labor Commissioner that all employees and apprentices performing manual labor on the project will have completed such a course;
- (8) Proof of completion may be demonstrated through either: (a) the presentation of a *bona fide* student course completion card issued by the federal OSHA Training Institute; *or* (2) the presentation of documentation provided to an employee by a trainer certified by the Institute pending the actual issuance of the completion card;
- (9) Any card with an issuance date more than 5 years prior to the commencement date of the construction project shall not constitute proof of compliance;

- (10) Each employer shall affix a copy of the construction safety course completion card to the certified payroll submitted to the contracting agency in accordance with Conn. Gen. Stat. § 31-53(f) on which such employee's name first appears;
- (11) Any employee found to be in non-compliance shall be subject to removal from the worksite if such employee does not provide satisfactory proof of course completion to the Labor Commissioner by the fifteenth day after the date the employee is determined to be in noncompliance;
- (12) Any such employee who is determined to be in noncompliance may continue to work on a public building construction project for a maximum of fourteen consecutive calendar days while bringing his or her status into compliance;
- (13) The Labor Commissioner may make complaint to the prosecuting authorities regarding any employer or agent of the employer, or officer or agent of the corporation who files a false certified payroll with respect to the status of an employee who is performing manual labor on a public building construction project;
- (14) The statute provides the minimum standards required for the completion of a safety course by manual laborers on public construction contracts; any contractor can exceed these minimum requirements; and
- (15) Regulations clarifying the statute are currently in the regulatory process, and shall be posted on the CTDOL website as soon as they are adopted in final form.
- (16) Any questions regarding this statute may be directed to the Wage and Workplace Standards Division of the Connecticut Labor Department via the internet website of <http://www.ctdol.state.ct.us/wgwkstnd/wgemenu.htm>; or by telephone at (860)263-6790.

**THE ABOVE INFORMATION IS PROVIDED EXCLUSIVELY AS AN EDUCATIONAL RESOURCE, AND IS NOT INTENDED AS A SUBSTITUTE FOR LEGAL INTERPRETATIONS WHICH MAY ULTIMATELY ARISE CONCERNING THE CONSTRUCTION OF THE STATUTE OR THE REGULATIONS.**



**Sec. 31-53b. Construction safety and health course. New miner training program. Proof of completion required for mechanics, laborers and workers on public works projects. Enforcement. Regulations. Exceptions.**

(a) Each contract for a public works project entered into on or after July 1, 2009, by the state or any of its agents, or by any political subdivision of the state or any of its agents, described in subsection (g) of section 31-53, shall contain a provision requiring that each contractor furnish proof with the weekly certified payroll form for the first week each employee begins work on such project that any person performing the work of a mechanic, laborer or worker pursuant to the classifications of labor under section 31-53 on such public works project, pursuant to such contract, has completed a course of at least ten hours in duration in construction safety and health approved by the federal Occupational Safety and Health Administration or, has completed a new miner training program approved by the Federal Mine Safety and Health Administration in accordance with 30 CFR 48 or, in the case of telecommunications employees, has completed at least ten hours of training in accordance with 29 CFR 1910.268.

(b) Any person required to complete a course or program under subsection (a) of this section who has not completed the course or program shall be subject to removal from the worksite if the person does not provide documentation of having completed such course or program by the fifteenth day after the date the person is found to be in noncompliance. The Labor Commissioner or said commissioner's designee shall enforce this section.

(c) Not later than January 1, 2009, the Labor Commissioner shall adopt regulations, in accordance with the provisions of chapter 54, to implement the provisions of subsections (a) and (b) of this section. Such regulations shall require that the ten-hour construction safety and health courses required under subsection (a) of this section be conducted in accordance with federal Occupational Safety and Health Administration Training Institute standards, or in accordance with Federal Mine Safety and Health Administration Standards or in accordance with 29 CFR 1910.268, as appropriate. The Labor Commissioner shall accept as sufficient proof of compliance with the provisions of subsection (a) or (b) of this section a student course completion card issued by the federal Occupational Safety and Health Administration Training Institute, or such other proof of compliance said commissioner deems appropriate, dated no earlier than five years before the commencement date of such public works project.

(d) This section shall not apply to employees of public service companies, as defined in section 16-1, or drivers of commercial motor vehicles driving the vehicle on the public works project and delivering or picking up cargo from public works projects provided they perform no labor relating to the project other than the loading and unloading of their cargo.

(P.A. 06-175, S. 1; P.A. 08-83, S. 1.)

History: P.A. 08-83 amended Subsec. (a) by making provisions applicable to public works project contracts entered into on or after July 1, 2009, replacing provision re total cost of work with reference to Sec. 31-53(g), requiring proof in certified payroll form that new mechanic, laborer or worker has completed a 10-hour or more construction safety course and adding provision re new miner training program, amended Subsec. (b) by substituting "person" for "employee" and adding "or program", amended Subsec. (c) by adding "or in accordance with Federal Mine

Safety and Health Administration Standards" and setting new deadline of January 1, 2009, deleted former Subsec. (d) re "public building", added new Subsec. (d) re exemptions for public service company employees and delivery drivers who perform no labor other than delivery and made conforming and technical changes, effective January 1, 2009.

November 29, 2006

**Notice**  
**To All Mason Contractors and Interested Parties**  
**Regarding Construction Pursuant to Section 31-53 of the**  
**Connecticut General Statutes (Prevailing Wage)**

The Connecticut Labor Department Wage and Workplace Standards Division is empowered to enforce the prevailing wage rates on projects covered by the above referenced statute.

Over the past few years the Division has withheld enforcement of the rate in effect for workers who operate a forklift on a prevailing wage rate project due to a potential jurisdictional dispute.

The rate listed in the schedules and in our Occupational Bulletin (see enclosed) has been as follows:

**Forklift Operator:**

- **Laborers (Group 4) Mason Tenders** - operates forklift solely to assist a mason to a maximum height of nine feet only.
- **Power Equipment Operator (Group 9)** - operates forklift to assist any trade and to assist a mason to a height over nine feet.

The U.S. Labor Department conducted a survey of rates in Connecticut but it has not been published and the rate in effect remains as outlined in the above Occupational Bulletin.

*Since this is a classification matter and not one of jurisdiction, effective January 1, 2007 the Connecticut Labor Department will enforce the rate on each schedule in accordance with our statutory authority.*

Your cooperation in filing appropriate and accurate certified payrolls is appreciated.

# Information Bulletin

## *Occupational Classifications*

The Connecticut Department of Labor has the responsibility to properly determine "job classification" on prevailing wage projects covered under C.G.S. Section 31-53.

*♪ Note: This information is intended to provide a sample of some occupational classifications for guidance purposes only. It is not an all-inclusive list of each occupation's duties. This list is being provided only to highlight some areas where a contractor may be unclear regarding the proper classification.*

**Below are additional clarifications of specific job duties performed for certain classifications:**

### **Asbestos Insulator**

- Handle, install, apply, fabricate, distribute, prepare, alter, repair, or dismantle heat and frost insulation, including penetration and fire stopping work on all penetration fire stop systems.

### **Carpenter**

- Assembly and installation of modular furniture/furniture systems.  
[New] a. Free-standing furniture is not covered. This includes: student chairs, study top desks, book box desks, computer furniture, dictionary stand, atlas stand, wood shelving, two- position information access station, file cabinets, storage cabinets, tables, etc.
- Applies fire stopping materials on fire resistive joint systems only.
- Installation of insulated material of all types whether blown, nailed or attached in other ways to walls, ceilings and floors of buildings.
- Installation of curtain/window walls only where attached to wood or metal studs.

### **Cleaning Laborer**

- The clean up of any construction debris and the general cleaning, including sweeping, wash down, mopping, wiping of the construction facility, washing, polishing, dusting, etc., prior to the issuance of a certificate of occupancy falls under the *Labor classification*.

### **Delivery Personnel (Revised)**

- If delivery of supplies/building materials is to one common point and stockpiled there, prevailing wages are not required. If the delivery personnel are involved in the distribution of the material to multiple locations within the construction site then they would have to be paid prevailing wages for the type of work performed: laborer, equipment operator, electrician, ironworker, plumber, etc.
- An example of this would be where delivery of drywall is made to a building and the delivery personnel distribute the drywall from one "stockpile" location to further sub-locations on each floor. Distribution of material around a construction site is the job of a laborer/tradesman and not a delivery personnel.

### **Electrician**

- Installation or maintenance of telecommunication, LAN wiring or computer equipment.
- Low voltage wiring.

### **Fork Lift Operator**

- Laborers Group 4) Mason Tenders - operates forklift solely to assist a mason to a maximum height of nine (9) feet only.
- Power Equipment Operator Group 9 - operates forklift to assist any trade, and to assist a mason to a height over nine (9) feet.

### **Glaziers**

- Installs light metal sash, head sills, and 2-story aluminum storefronts.
- Installation of aluminum window walls and curtain walls is the "joint work" of the Glaziers and Ironworkers classification which requires either a blended rate or equal composite workforce.

### **Ironworkers**

- Handling, sorting, and installation of reinforcing steel (rebar).
- Installation of aluminum window walls and curtain walls is the "joint work" of the Glaziers and Ironworkers classification which requires either a blended rate or equal composite workforce. Insulated metal and insulated composite panels are still installed by the Ironworker.
- Metal bridge rail (traffic), metal bridge handrail, and decorative security fence installation.

## **Insulator**

- Installing fire stopping systems/materials for "Penetration Firestop Systems": transit to cables, electrical conduits, insulated pipes, sprinkler pipe penetrations, ductwork behind radiation, electrical cable trays, fire rated pipe penetrations, natural polypropylene, HVAC ducts, plumbing bare metal, telephone and communication wires, and boiler room ceilings. Past practice using the applicable licensed trades, Plumber, Sheet Metal, Sprinkler Fitter, and Electrician, is not inconsistent with the Insulator classification and would be permitted.

## **Lead Paint Removal**

- Painter Rate
  1. Removal of lead paint from bridges.
  2. Removal of lead paint as preparation of any surface to be repainted.
  3. Where removal is on a Demolition project prior to reconstruction.
- Laborer Rate
  1. Removal of lead paint from any surface NOT to be repainted.
  2. Where removal is on a *TOTAL* Demolition project only.

## **Roofers**

- Preparation of surface, tear-off and/or removal of any type of roofing, and/or clean-up of any areas where a roof is to be relaid.

## **Sheet Metal Worker**

- Fabrication, handling, assembling, erecting, altering, repairing, etc. of coated metal material panels and composite metal material panels when used on building exteriors and interiors as soffits, fascia, louvers, partitions, wall panel siding, canopies, cornice, column covers, awnings, beam covers, cladding, sun shades, lighting troughs, spires, ornamental roofing, metal ceilings, mansards, copings, ornamental and ventilation hoods, vertical and horizontal siding panels, trim, etc. The sheet metal classification also applies to the vast variety of coated metal material panels and composite metal material panels that have evolved over the years as an alternative to conventional ferrous and non-ferrous metals like steel, iron, tin, copper, brass, bronze, aluminum, etc. Insulated metal and insulated composite panels are still installed by the Iron Worker. Fabrication, handling, assembling, erecting, altering, repairing, etc. of architectural metal roof, standing seam roof, composite metal roof, metal and composite bathroom/toilet partitions, aluminum gutters, metal and composite lockers and shelving, kitchen equipment, and walk-in coolers.

## Truck Drivers

- Truck Drivers delivering asphalt are covered under prevailing wage while on the site and directly involved in the paving operation.
- Material men and deliverymen are not covered under prevailing wage as long as they are not directly involved in the construction process. If, they unload the material, they would then be covered by prevailing wage for the classification they are performing work in: laborer, equipment operator, etc.
- Hauling material off site is not covered provided they are not dumping it at a location outlined above.
- Driving a truck on site and moving equipment or materials on site would be considered covered work, as this is part of the construction process.

 Any questions regarding the proper classification should be directed to the Contract Compliance Unit, Wage and Workplace Standards Division, Connecticut Department of Labor, 200 Folly Brook Blvd, Wethersfield, CT 06 109 at (860) 263-6543.

Project: Hebron Avenue And New London Turnpike Intersection Improvements

**Minimum Rates and Classifications  
for Heavy/Highway Construction**

**Connecticut Department of Labor  
Wage and Workplace Standards Division**

ID#: H 18920

By virtue of the authority vested in the Labor Commissioner under provisions of Section 31-53 of the General Statutes of Connecticut, as amended, the following are declared to be the prevailing rates and welfare payments and will apply only where the contract is advertised for bid within 20 days of the date on which the rates are established. Any contractor or subcontractor not obligated by agreement to pay to the welfare and pension fund shall pay this amount to each employee as part of his/her hourly wages.

Project Number: PW-1205

Project Town: Glastonbury

FAP Number:

State Number:

Project: Hebron Avenue And New London Turnpike Intersection Improvements

**CLASSIFICATION**

**Hourly Rate**

**Benefits**

01) Asbestos/Toxic Waste Removal Laborers: Asbestos removal and encapsulation (except its removal from mechanical systems which are not to be scrapped), toxic waste removers, blasters. \*\*See Laborers Group 5 and 7\*\*

1) Boilermaker	33.79	34% + 8.96
1a) Bricklayer, Cement Masons, Cement Finishers, Plasterers, Stone Masons	32.50	27.06
2) Carpenters, Piledrivermen	30.45	21.65

*As of:* Monday, March 17, 2014



Project: Hebron Avenue And New London Turnpike Intersection Improvements

2a) Diver Tenders	30.45	21.65
3) Divers	38.91	21.65
4) Painters: (Bridge Construction) Brush, Roller, Blasting (Sand, Water, etc.), Spray	44.25	17.75
4a) Painters: Brush and Roller	30.62	17.75
4b) Painters: Spray Only	33.62	17.75
4c) Painters: Steel Only	32.62	17.75
4d) Painters: Blast and Spray	33.62	17.75

*As of:*

Monday, March 17, 2014

Project: Hebron Avenue And New London Turnpike Intersection Improvements

4e) Painters: Tanks, Tower and Swing	32.62	17.75
5) Electrician (Trade License required: E-1,2 L-5,6 C-5,6 T-1,2 L-1,2 V-1,2,7,8,9)	37.60	22.22+3% of gross wage
6) Ironworkers: Ornamental, Reinforcing, Structural, and Precast Concrete Erection	33.50	28.98
7) Plumbers (Trade License required: (P-1,2,6,7,8,9 J-1,2,3,4 SP-1,2) and Pipefitters (Including HVAC Work) (Trade License required: S-1,2,3,4,5,6,7,8 B-1,2,3,4 D-1,2,3,4 G-1, G-2, G-8, G-9)	39.31	26.27
----LABORERS----		
8) Group 1: Laborer (Unskilled), Common or General, acetylene burner, concrete specialist	26.40	17.15
9) Group 2: Chain saw operators, fence and guard rail erectors, pneumatic tool operators, powdermen, air tool operator	26.65	17.15

*As of:*

Monday, March 17, 2014

Project: Hebron Avenue And New London Turnpike Intersection Improvements

10) Group 3: Pipelayers	26.90	17.15
11) Group 4: Jackhammer/Pavement breaker (handheld); mason tenders (cement/concrete), catch basin builders, asphalt rakers, air track operators, block pavers and curb setters	26.90	17.15
12) Group 5: Toxic waste removal (non-mechanical systems)	28.40	17.15
13) Group 6: Blasters	28.15	17.15
Group 7: Asbestos Removal, non-mechanical systems (does not include leaded joint pipe)	27.40	17.15
Group 8: Traffic control signalmen	16.00	17.15

----LABORERS (TUNNEL CONSTRUCTION, FREE AIR). Shield Drive and Liner Plate Tunnels in Free Air.----

*As of:* Monday, March 17, 2014

Project: Hebron Avenue And New London Turnpike Intersection Improvements

13a) Miners, Motormen, Mucking Machine Operators, Nozzle Men, Grout Men, Shaft & Tunnel Steel & Rodmen, Shield & Erector, Arm Operator, Cable Tenders	31.28	17.15 + a
--	-------	-----------

13b) Brakemen, Trackmen	30.37	17.15 + a
-------------------------	-------	-----------

---CLEANING, CONCRETE AND CAULKING TUNNEL---

14) Concrete Workers, Form Movers, and Strippers	30.37	17.15 + a
--	-------	-----------

15) Form Erectors	30.68	17.15 + a
-------------------	-------	-----------

---ROCK SHAFT LINING, CONCRETE, LINING OF SAME AND TUNNEL  
IN FREE AIR:---

16) Brakemen, Trackmen, Tunnel Laborers, Shaft Laborers	30.37	17.15 + a
---	-------	-----------

*As of:* Monday, March 17, 2014

Project: Hebron Avenue And New London Turnpike Intersection Improvements

17) Laborers Topside, Cage Tenders, Bellman	30.26	17.15 + a
18) Miners	31.28	17.15 + a
----TUNNELS, CAISSON AND CYLINDER WORK IN COMPRESSED AIR: ----		
18a) Blaster	37.41	17.15 + a
19) Brakemen, Trackmen, Groutman, Laborers, Outside Lock Tender, Gauge Tenders	37.22	17.15 + a
20) Change House Attendants, Powder Watchmen, Top on Iron Bolts	35.35	17.15 + a
21) Mucking Machine Operator	37.97	17.15 + a

*As of:*

Monday, March 17, 2014

Project: Hebron Avenue And New London Turnpike Intersection Improvements

----TRUCK DRIVERS----(\*see note below)

Two axle trucks	27.88	18.27 + a
Three axle trucks; two axle ready mix	27.98	18.27 + a
Three axle ready mix	28.03	18.27 + a
Four axle trucks, heavy duty trailer (up to 40 tons)	28.08	18.27 + a
Four axle ready-mix	28.13	18.27 + a
Heavy duty trailer (40 tons and over)	28.33	18.27 + a

*As of:* Monday, March 17, 2014

Project: Hebron Avenue And New London Turnpike Intersection Improvements

Specialized earth moving equipment other than conventional type on-the road trucks and semi-trailer (including Euclids)	28.13	18.27 + a
---	-------	-----------

----POWER EQUIPMENT OPERATORS----

Group 1: Crane handling or erecting structural steel or stone, hoisting engineer (2 drums or over), front end loader (7 cubic yards or over), Work Boat 26 ft. & Over. (Trade License Required)	36.05	21.55 + a
---	-------	-----------

Group 2: Cranes (100 ton rate capacity and over); Backhoe/Excavator over 2 cubic yards; Piledriver (\$3.00 premium when operator controls hammer). (Trade License Required)	35.73	21.55 + a
---	-------	-----------

Group 3: Excavator/Backhoe under 2 cubic yards; Cranes (under 100 ton rated capacity), Gradall; Master Mechanic; Hoisting Engineer (all types of equipment where a drum and cable are used to hoist or drag material regardless of motive power of operation), Rubber Tire Excavator (Drott-1085 or similar); Grader Operator; Bulldozer Fine Grade (slopes, shaping, laser or GPS, etc.). (Trade License Required)	34.99	21.55 + a
---	-------	-----------

Group 4: Trenching Machines; Lighter Derrick; Concrete Finishing Machine; CMI Machine or Similar; Koehring Loader (Skooper)	34.60	21.55 + a
---	-------	-----------

Group 5: Specialty Railroad Equipment; Asphalt Paver; Asphalt Spreader; Asphalt Reclaiming Machine; Line Grinder; Concrete Pumps; Drills with Self Contained Power Units; Boring Machine; Post Hole Digger; Auger; Pounder; Well Digger; Milling Machine (over 24" Mandrell)	34.01	21.55 + a
--	-------	-----------

Project: Hebron Avenue And New London Turnpike Intersection Improvements

Group 5 continued: Side Boom; Combination Hoe and Loader; Directional Driller.	34.01	21.55 + a
Group 6: Front End Loader (3 up to 7 cubic yards); Bulldozer (rough grade dozer).	33.70	21.55 + a
Group 7: Asphalt Roller; Concrete Saws and Cutters (ride on types); Vermeer Concrete Cutter; Stump Grinder; Scraper; Snooper; Skidder; Milling Machine (24" and Under Mandrel).	33.36	21.55 + a
Group 8: Mechanic, Grease Truck Operator, Hydroblaster, Barrier Mover, Power Stone Spreader; Welder; Work Boat under 26 ft.; Transfer Machine.	32.96	21.55 + a
Group 9: Front End Loader (under 3 cubic yards), Skid Steer Loader regardless of attachments (Bobcat or Similar); Fork Lift, Power Chipper; Landscape Equipment (including hydroseeder).	32.53	21.55 + a
Group 10: Vibratory Hammer, Ice Machine, Diesel and Air Hammer, etc.	30.49	21.55 + a
Group 11: Conveyor, Earth Roller; Power Pavement Breaker (whiphammer), Robot Demolition Equipment.	30.49	21.55 + a

*As of:*

Monday, March 17, 2014



Project: Hebron Avenue And New London Turnpike Intersection Improvements

Group 12: Wellpoint Operator.	30.43	21.55 + a
Group 13: Compressor Battery Operator.	29.85	21.55 + a
Group 14: Elevator Operator; Tow Motor Operator (Solid Tire No Rough Terrain).	28.71	21.55 + a
Group 15: Generator Operator; Compressor Operator; Pump Operator; Welding Machine Operator; Heater Operator.	28.30	21.55 + a
Group 16: Maintenance Engineer/Oiler	27.65	21.55 + a
Group 17: Portable asphalt plant operator; portable crusher plant operator; portable concrete plant operator.	31.96	21.55 + a
Group 18: Power Safety Boat; Vacuum Truck; Zim Mixer; Sweeper; (minimum for any job requiring CDL license).	29.54	21.55 + a

*As of:*

Monday, March 17, 2014

Project: Hebron Avenue And New London Turnpike Intersection Improvements

\*\*NOTE: SEE BELOW

----LINE CONSTRUCTION----(Railroad Construction and Maintenance)----

20) Lineman, Cable Splicer, Dynamite Man	44.36	3% + 13.70
--	-------	------------

21) Heavy Equipment Operator	39.92	3% + 13.70
------------------------------	-------	------------

22) Equipment Operator, Tractor Trailer Driver, Material Men	37.71	3% + 13.70
--	-------	------------

23) Driver Groundmen	33.27	3% + 13.70
----------------------	-------	------------

----LINE CONSTRUCTION----

Project: Hebron Avenue And New London Turnpike Intersection Improvements

24) Driver Groundmen	30.92	6.5% + 9.70
25) Groundmen	22.67	6.5% + 6.20
26) Heavy Equipment Operators	37.10	6.5% + 10.70
27) Linemen, Cable Splicers, Dynamite Men	41.22	6.5% + 12.20
28) Material Men, Tractor Trailer Drivers, Equipment Operators	35.04	6.5% + 10.45

*As of:*

Monday, March 17, 2014

Project: Hebron Avenue And New London Turnpike Intersection Improvements

*Welders: Rate for craft to which welding is incidental.*

*\*Note: Hazardous waste removal work receives additional \$1.25 per hour for truck drivers.*

*\*\*Note: Hazardous waste premium \$3.00 per hour over classified rate*

- Crane with 150 ft. boom (including jib) - \$1.50 extra
- Crane with 200 ft. boom (including jib) - \$2.50 extra
- Crane with 250 ft. boom (including jib) - \$5.00 extra
- Crane with 300 ft. boom (including jib) - \$7.00 extra
- Crane with 400 ft. boom (including jib) - \$10.00 extra

All classifications that indicate a percentage of the fringe benefits must be calculated at the percentage rate times the "base hourly rate".

Apprentices duly registered under the Commissioner of Labor's regulations on "Work Training Standards for Apprenticeship and Training Programs" Section 31-51-d-1 to 12, are allowed to be paid the appropriate percentage of the prevailing journeymen hourly base and the full fringe benefit rate, providing the work site ratio shall not be less than one full-time journeyman instructing and supervising the work of each apprentice in a specific trade.

*~~Connecticut General Statute Section 31-55a: Annual Adjustments to wage rates by contractors doing state work  
~~*

*The Prevailing wage rates applicable to this project are subject to annual adjustments each July 1st for the duration of the project.*

*Each contractor shall pay the annual adjusted prevailing wage rate that is in effect each July 1st, as posted by the Department of Labor.*

*It is the contractor's responsibility to obtain the annual adjusted prevailing wage rate increases directly from the Department of Labor's website.*

*The annual adjustments will be posted on the Department of Labor's Web page:  
[www.ct.gov/dol](http://www.ct.gov/dol).*

*The Department of Labor will continue to issue the initial prevailing wage rate schedule to the Contracting Agency for the project.*

*All subsequent annual adjustments will be posted on our Web Site for contractor access.*

*Contracting Agencies are under no obligation pursuant to State labor law to pay any increase due to the annual adjustment provision.*

**As of:** Monday, March 17, 2014

Project: Hebron Avenue And New London Turnpike Intersection Improvements

*Effective October 1, 2005 - Public Act 05-50: any person performing the work of any mechanic, laborer, or worker shall be paid prevailing wage*

All Person who perform work ON SITE must be paid prevailing wage for the appropriate mechanic, laborer, or worker classification.

All certified payrolls must list the hours worked and wages paid to All Persons who perform work ON SITE regardless of their ownership i.e.: (Owners, Corporate Officers, LLC Members, Independent Contractors, et. al)

Reporting and payment of wages is required regardless of any contractual relationship alleged to exist between the contractor and such person.

**~~Unlisted classifications needed for work not included within the scope of the classifications listed may be added after award only as provided in the labor standards contract clause (29 CFR 5.5 (a) (1) (ii)).**

Please direct any questions which you may have pertaining to classification of work and payment of prevailing wages to the Wage and Workplace Standards Division, telephone (860)263-6790.

*As of:*

Monday, March 17, 2014

**CONNECTICUT DEPARTMENT OF LABOR**  
**Wage and Workplace Standards Division**

**FOOTNOTES**

Please Note: If the “Benefits” listed on the schedule for the following occupations includes a letter(s) (+ a or + a+b for instance), refer to the information below.

Benefits to be paid at the appropriate prevailing wage rate for the listed occupation.

If the “Benefits” section for the occupation lists only a dollar amount, disregard the information below.

**Bricklayers, Cement Masons, Cement Finishers, Plasters, Stone Masons**  
(Building Construction)  
(Residential- Hartford, Middlesex, New Haven, New London and Tolland Counties)

- a. Paid Holiday: Employees shall receive 4 hours for Christmas Eve holiday provided the employee works the regularly scheduled day before and after the holiday. Employers may schedule work on Christmas Eve and employees shall receive pay for actual hours worked in addition to holiday pay.

**Bricklayer (Residential- Fairfield County)**

- a. Paid Holiday: If an employee works on Christmas Eve until noon he shall be paid for 8 hours.

**Electricians**

Fairfield County: West of the Five Mile River in Norwalk

- a. \$2.00 per hour not to exceed \$14.00 per day.

**Elevator Constructors: Mechanics**

- a. Paid Holidays: New Year’s Day, Memorial Day, Independence Day, Labor Day, Thanksgiving Day, Christmas Day, plus the Friday after Thanksgiving.
- b. Vacation: Employer contributes 8% of basic hourly rate for 5 years or more of service or 6% of basic hourly rate for 6 months to 5 years of service as vacation pay credit.

### **Glaziers**

- a. Paid Holidays: Labor Day and Christmas Day.

### **Power Equipment Operators**

(Heavy and Highway Construction & Building Construction)

- a. Paid Holidays: New Year's Day, Good Friday, Memorial day, Independence Day, Labor Day, Thanksgiving Day and Christmas Day, provided the employee works 3 days during the week in which the holiday falls, if scheduled, and if scheduled, the working day before and the working day after the holiday. Holidays falling on Saturday may be observed on Saturday, or if the employer so elects, on the preceding Friday.

### **Ironworkers**

- a. Paid Holiday: Labor Day provided employee has been on the payroll for the 5 consecutive workdays prior to Labor Day.

### **Laborers (Tunnel Construction)**

- a. Paid Holidays: New Year's Day, Memorial Day, Independence Day, Labor Day, Thanksgiving Day and Christmas Day. No employee shall be eligible for holiday pay when he fails, without cause, to work the regular workday preceding the holiday or the regular workday following the holiday.

### **Roofers**

- a. Paid Holidays: July 4<sup>th</sup>, Labor Day, and Christmas Day provided the employee is employed 15 days prior to the holiday.

### **Sprinkler Fitters**

- a. Paid Holidays: Memorial Day, July 4th, Labor Day, Thanksgiving Day and Christmas Day, provided the employee has been in the employment of a contractor 20 working days prior to any such paid holiday.

### **Truck Drivers**

(Heavy and Highway Construction & Building Construction)

- a. Paid Holidays: New Year's Day, Memorial Day, Independence Day, Labor Day, Thanksgiving Day, Christmas day, and Good Friday, provided the employee has at least 31 calendar days of service and works the last scheduled day before and the first scheduled day after the holiday, unless excused.

ATTACHMENT B: CONSTRUCTION PLANS